

SERIES 400 / 450 / & 500
Installation, Operation and
Maintenance Manual

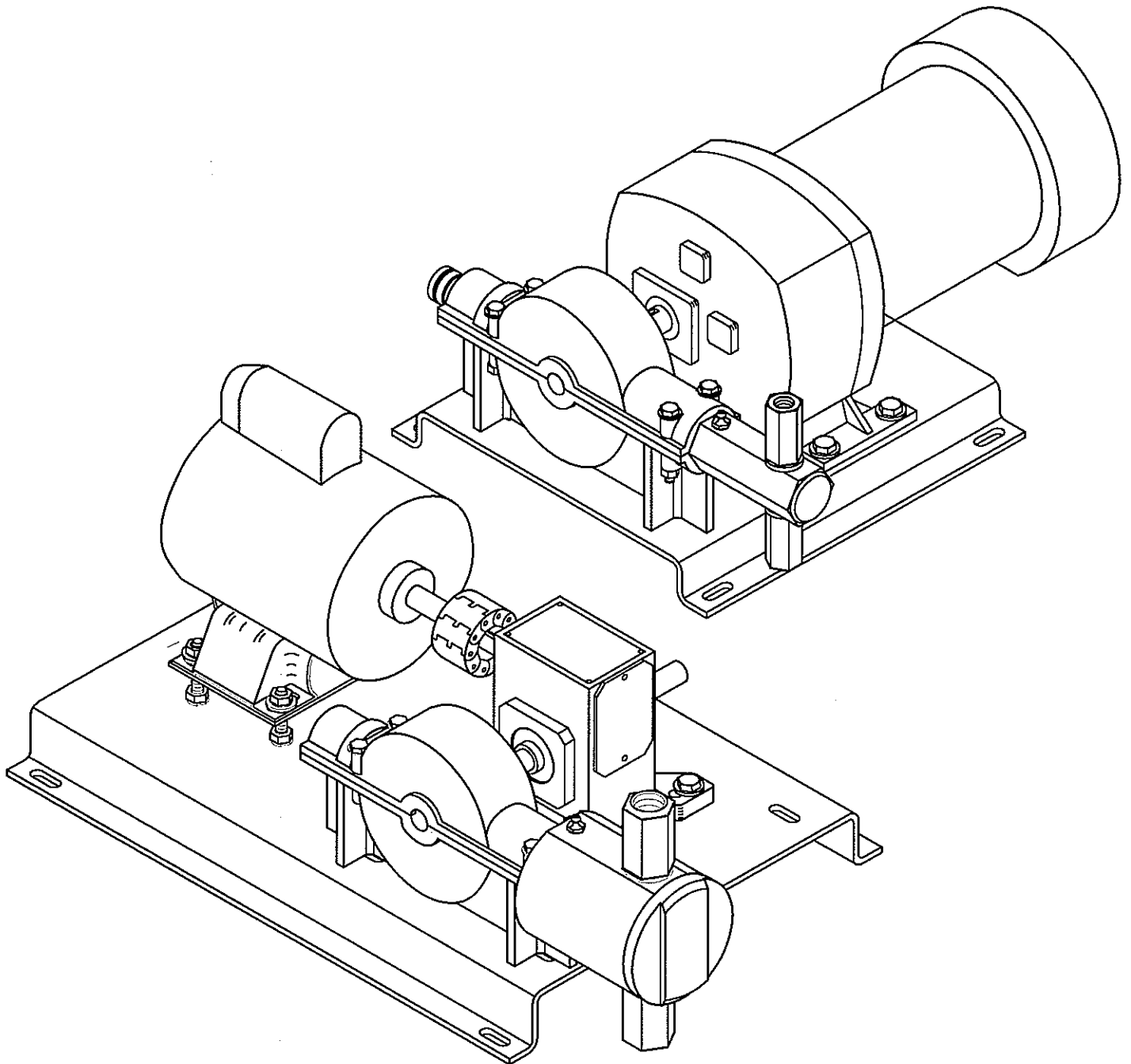

READ ALL WARNINGS CAREFULLY BEFORE
INSTALLING PUMP

PUMP DATA / SPECIFICATIONS

Fill in information from pump data label

Series: _____
Serial #: _____
Model #: _____
Nominal output: _____
Maximum pressure: _____
Volts/Hz/Amps/Phase: _____
KOPkit® #: _____
Tubing material/size: _____

NOTES:

WARRANTY:

The manufacturer warrants its equipment of its manufacture to be free of defects in material or workmanship. Liability under this policy extends to eighteen(18) months from the date of purchase or one(1) year from date of installation or whichever comes first. The manufacturer's liability is limited to repair or replacement of any device or part, which is returned, prepaid, to the factory and which is proven defective upon examination. This warranty does not include installation or repair costs and in no event shall the manufacturer's liability exceed the selling price of such part.

The manufacturer disclaims all liability for damage to its products through improper installation, maintenance, use or attempts to operate such products beyond their functional capacity, intentionally or otherwise, or any unauthorized repair. Replaceable elastomeric parts are expendable and are not covered by any warranty either expressed or implied. The manufacturer is not responsible for consequential or other damages, injuries or expense incurred through use of its products.

The above warranty is in lieu of any other warranty, either expressed or implied. The manufacturer makes no warranty of fitness or merchantability. No agent of ours is authorized to make any warranty other than the above.

TABLE OF CONTENTS

SAFETY INSTRUCTIONS	PAGE 3
INTRODUCTION	PAGE 4
PRECAUTIONS FOR OPERATION	PAGE 4
GENERAL INFORMATION	PAGE 4
PUMP CHARACTERISTICS	PAGE 5
MATERIALS OF CONSTRUCTION	PAGE 7
INSTALLATION	PAGE 7
MAINTENANCE	PAGE 9
REPLACEMENT OF PISTON, PACKING AND PUMP HEAD	PAGE 10
TROUBLE SHOOTING	PAGE 12
SERIES 400 & 450 PARTS DIAGRAM	PAGE 14
SERIES 500 PARTS DIAGRAM	PAGE 16

SAFETY INSTRUCTIONS

READ ALL INSTRUCTIONS PRIOR TO USE

- *** **⚠ DANGER** Secure chemicals & metering pumps, making them inaccessible to children and pets.
- *** **DO NOT PUMP FLAMMABLE LIQUIDS.**
- *** To reduce the risk of electric shock -before maintenance, repair, or moving pump- disconnect the power cord.
- *** Do not cut the plug or ground lug off the electrical cord. Consult a licensed electrician for proper installation.
- *** If the supply cord is damaged, it must be replaced by the manufacturer or its service agent or similarly qualified person in order to avoid a hazard.
- ** **⚠ WARNING** Always wear protective clothing, including gloves and safety glasses, when working on or near chemical metering pumps; consult manufacture for protective equipment recommendations.
- ** Inspect tubing regularly for cracking or deterioration and replace as necessary. **(Always wear protective clothing and safety glasses when inspecting tubing.)**
- ** If the pump is exposed to direct sunlight, use a U.V. resistant tubing.
- ** Follow directions and warnings provided from the chemical manufacturer. The user is responsible for determining the chemical compatibility with the chemical feed pump.
- ** Make sure the voltage on the pump data label matches the installation voltage. If pump fails to start, check line voltage.
- ** Consult with local health officials and/or qualified water conditioning specialists when treating potable water.
- ** Always depressurize system and drain prior to installation or maintenance.
- ** **DO NOT MODIFY PUMP.** This poses a potentially dangerous situation and will void the warranty.
- * **⚠ CAUTION** All pumps are factory tested with water. Remove tubing and thoroughly dry if the chemical being pumped will react with water (i.e. sulfuric acid).
- * Consult a licensed plumber and electrician before installation to conform to local codes.
- * **NOTE:** For accurate volume output, the pump must be **calibrated** under **all** operating conditions.

INTRODUCTION

The Series 400, 450 and 500 are reciprocating, positive displacement, piston type metering pumps. With a micrometer type adjustment, the cam bearing assembly will make more or less contact with the slide arm and piston assembly. This results in increasing or decreasing the piston stroke length; thereby accurately controlling output capacity. This adjustment is possible when there exists positive differential pressure (discharge pressure exceeds suction pressure).

The four check valves (double suction and discharge) help insure that predetermined amounts of liquid consistently move to the point of injection without backflow. This allows accurate metering and a high degree of repeatability from one setting to the next.

PRECAUTIONS FOR OPERATION

Each Series 400, 450 and 500 pump has been tested to meet prescribed specifications and certain safety standards. However, a few precautionary notes should be adhered to at all times.

CAUTION THOROUGHLY READ ALL CAUTIONS PRIOR TO INSTALLING PUMP.

1. Install the pump in a place convenient for its future maintenance and inspection, then fix it to prevent vibration.
2. Protective caps must be removed prior to installing tubing onto valve assemblies. Use tubing of specified size. Connect the tubing to the suction side securely to prevent the entrance of outside air. Make sure that there is no liquid leakage on the discharge side.
3. Each pump is equipped with a three-prong plug. Always be sure the pump is grounded. To disconnect, do not pull wire, but grip the plug with fingers and pull out.
4. Chemicals used may be dangerous and should be used carefully and according to warnings on the label. Follow the directions given with each type of chemical. Do not assume chemicals are the same because they look alike. Always store chemicals in a safe location away from children and others. We cannot be responsible for the misuse of chemicals being fed by the pump. Always have the material safety data sheet (MSDS) available for any fluid being pumped.
5. When metering hazardous material **NO NOT** use plastic tubing. Strictly use proper rigid pipe. Consult supplier for special adaptors or valve assemblies.

GENERAL INFORMATION

1. Series 400, 450, 500 chemical feed pumps are supplied in simplex or duplex construction. The Series 400 and 450 configuration is direct-drive type (gear motor to pump(s)). The Series 500 configuration utilizes a standard 56 frame motor coupled to a speed reducer, which in turn is coupled to the pumping mechanism. Series 400 and 450 pumps can be provided for 30 or 60 strokes/minute. Series 500 is available in 29, 57, or 115 strokes/minute.
2. When purchased alone,, Series 400 and 500 pumps are provided with National Pipe Thread connections for both suction and discharge. Series 450 provided with compression type tubing connection for .31" I.D. x .44" O.D. suction tubing (PVC) AND .38" I.D. x .50" O.D. discharge tubing (Polypropylene) high pressure tubing.
3. Series 400 chemical pumps with less than 1' diameter pistons are supplied with a PVC pressure relief valve (41585), which is pre-set at 150° PSI unless otherwise specified. Maximum pressure for PVC construction is 250° PSI. Series 450 chemical pumps can also be supplied with the same pressure relief valve when ordered separately. (See figure #3).

4. The standard motor available for Series 400 and 450 is TEFC 115/230v 50/60hz, single phase. The standard motor for the Series 500 is open drip-proof 115v 60hz, single phase. TEFC and explosion-proof are available for Series 500 pumps. A variety of voltage and frequency options are also available for the Series 500.

5. Each standard pump is shipped with the following:

Series 400 Pump:

- Chemical Pump with Motor 115/230v 50/60hz. Single phase TEFC
- Pressure Relief Valve
- Operation & Instruction Manual

Series 450 Pump:

- Chemical Pump with Motor 115/230v 50/60hz. single phase TEFC
- Back Check Valve
- Strainer Assembly
- Suction Tubing -4 ft. (PVC)
- Discharge Tubing -8 ft. (Polyethylene)
- Operation & Instruction Manual

Series 500 Pump:

- Chemical Pump with Motor 115v 60hz. ODP
- Speed Reducer
- Operation & Instruction Manual

PUMP CHARACTERISTICS

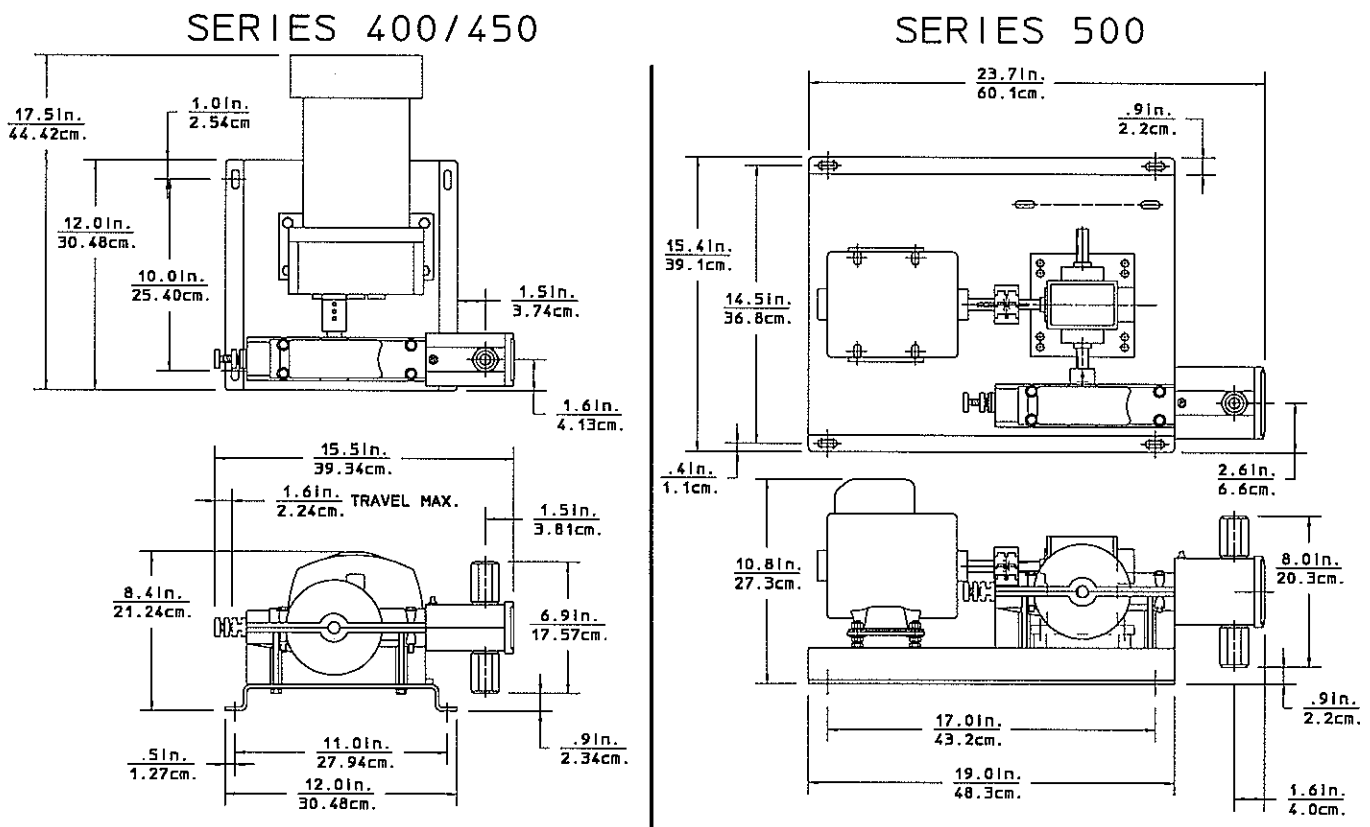

Inlet and outlet connections for Series 400 with piston diameter up to 5/8" are 1/4" FNPT. Inlet and outlet connections for Series 400 and 500 with piston diameters 1" and larger are 1/2" FNPT. Series 450 inlet and outlet connections are compression type, suitable to 5/16" x 7/16" suction tubing and 3/8" x 1/2" discharge tubing. The Series 450 can also be provided with 1/2" MNPT connections on request.

Series 400, 450 and 500 have a standard, double check valves on the suction and discharge side of the pump head.

Suction lift is 10 feet for all Series 400, 450 and 500 pumps (based on water).

Pump output is adjustable over a 10:1 range while pump is still in operation. Adjustment for all Series pumps are micrometer type (standard).

Pumping mechanism is cam actuated piston.

Pump assembly has all lubricated mechanical components.

Maximum operating temperature for Series 400 and 500 chemical pumps is 180° F. Maximum operating temperature for Series 450 is 125° F.

Pump motor operating temperature is usually 40° C. Above ambient. Class A installation is standard. Class B is available upon request.

SERIES 400/450							
MODEL #	OUTPUT CAPACITY GPH / LPH	STROKES PER MINUTE	MAXIMUM OPERATING PRESSURE	PUMP BODY	MOTOR	PISTON DIAMETER	SHIPPING WEIGHT
* 405	.50 / 1.89	30	800 psi / 56 kgcm ²	SIMPLEX	1/4 h.p.	1/4"	48 lbs., ----
* 406	1.00 / 3.76			DUPLEX		6.35mm	
* 409	.81 / 3.06			SIMPLEX		3/8"	21.7 kg.
* 410	1.72 / 6.50			DUPLEX		9.525mm	
* 413	1.00 / 3.78	60		SIMPLEX		1/4"	55 lbs., ----
* 414	2.00 / 7.56			DUPLEX		6.35mm	
* 417	1.62 / 6.12			SIMPLEX		3/8"	
* 418	3.24 / 12.25			DUPLEX		9.525mm	
* 425	1.65 / 6.24	30		SIMPLEX		1/2"	25 kg.
* 426	3.30 / 12.47			DUPLEX		12.70mm	
* 429	3.10 / 11.72			SIMPLEX		5/8"	
* 430	6.20 / 23.44			DUPLEX		15.875mm	
* 433	3.30 / 12.47	60	SIMPLEX	1/2"	48 lbs., ----		
* 434	6.60 / 24.95		DUPLEX	12.70mm			
* 437	6.20 / 23.47		SIMPLEX	5/8"			
* 438	12.40 / 46.94		DUPLEX	15.875mm			
441	8.50 / 32.13	30	300 psi / 21 kgcm ²	SIMPLEX	1/4 h.p.	1"	55 lbs., ----
442	17.00 / 64.25			DUPLEX		25.4mm	
445	17.00 / 64.25	60		SIMPLEX		25.4mm	25 kg.
446	34.00 / 128.52			DUPLEX			

* FOR SERIES 450 CONFIGURATION ADD 'PV' AFTER SERIES 400 MODEL #.
(SERIES 450 MODELS NOT AVAILABLE WITH 1" PISTON HEAD.)

SERIES 500							
MODEL #	OUTPUT CAPACITY GPH / LPH	STROKES PER MINUTE	MAXIMUM OPERATING PRESSURE	PUMP BODY	MOTOR	PISTON DIAMETER	SHIPPING WEIGHT
541	6.97 / 26.38	29	500 psi / 35 kgcm ²	SIMPLEX	1/3 h.p.	1.00" 25.44mm	85 lbs.
542	13.95 / 52.76			DUPLEX			105 lbs.
545	13.70 / 51.85	57		SIMPLEX	1/2 h.p.		85 lbs.
546	27.41 / 103.71			DUPLEX			105 lbs.
548	27.65 / 104.65	115	SIMPLEX	1 h.p.	85 lbs.		
572	55.30 / 209.31		DUPLEX		105 lbs.		
551	10.89 / 41.24	29	300 psi / 21 kgcm ²	SIMPLEX	1/3 h.p.	1.25" 31.40mm	93 lbs.
552	21.78 / 82.48			DUPLEX			121 lbs.
553	21.41 / 81.06	57		SIMPLEX	1/2 h.p.		93 lbs.
554	42.82 / 162.12			DUPLEX			121 lbs.
559	43.20 / 163.54	115	SIMPLEX	1 h.p.	93 lbs.		
560	86.40 / 327.08		DUPLEX		121 lbs.		
561	15.69 / 59.387	29	200 psi / 14 kgcm ²	SIMPLEX	1/3 h.p.	1.50" 38.16mm	96 lbs.
562	31.38 / 118.77			DUPLEX			127 lbs.
563	30.83 / 116.69	57		SIMPLEX	1/2 h.p.		96 lbs.
564	61.66 / 233.38			DUPLEX			127 lbs.
569	62.21 / 235.46	115	SIMPLEX	1 h.p.	96 lbs.		
570	124.42 / 470.93		DUPLEX		127 lbs.		

MATERIALS OF CONSTRUCTION

Series 400 and 500 pump heads are standard cold rolled steel with 304 stainless steel optional. Series 450 pump head is PVC.

Series 400 and 500 valves are 304 stainless steel. Series 450 valves are PVC.

Pistons are ground and polished 303 stainless steel.

Standard ball checks for Series 400 (piston size less than 1") and 450 are ceramic. Standard for series 400 (piston size 1") and 500 are 316 stainless steel. Optional ball checks for Series 400 (piston size 1"), 450 and 500 are Teflon.

Pump housing for all Series is heavy-duty chemically resistant thermo-plastic (styrene acrylonitril-35% glass filled).

All fasteners for all three Series are 18/8 stainless steel.

Piston packing for all three Series can be either neoprene or Teflon. Neoprene is standard with cold rolled steel pump heads and Teflon is standard with 304 stainless steel heads.

Grease gland for Series 400 and 450 is schedule 40 PVC. No grease gland is required for models with 1", 1-1/4", 1-1/2" diameter piston.

For all three Series the grease used in head assembly and cam bearing assembly area is Mobilith AW2 NGL1 #2 extreme pressure lithium grease.

For Series 500, speed reducer gear oil is Exxon Spartan EP 68, or equivalent.

INSTALLATION

All Series 400, 450, and 500 chemical pumps can be supplied with Series 7000, 8000, or 9000 tank systems. The pump may be mounted to tank base for shipping.

Flooded suction configuration (pump mounted at the base of or under, the chemical solution tank) is generally recommended as the most trouble-free method of installation. If this is not possible, due to application limitations, the Series 400, 450, and 500 can be mounted over, or on top of, the solution container. **THE MAXIMUM LIFT OF THE CHEMICAL PUMP, FOR WATER, IS 10 FEET. BE SURE NOT TO EXCEED THIS HEIGHT.**

NOTE: The chemical pump should always be mounted on a horizontal plane.

Before start-up be **sure the voltage of the chemical feeder matches the voltage of the power supply.** 115/230V 50/60hz. Single phase is standard. Other voltage requirements can readily be furnished. Power requirements and motor configuration should always be noted when the unit is ordered.

When priming, make sure the pump capacity (Series 400, 450 and 500) is set at 100%. This can only be noted when the pump is operating. The following steps apply to all three Series of piston pumps.

1. Be sure there is no pressure in discharge line.
2. Disconnect discharge and suction tubing or piping.
3. The setting of the unit can be noted while pump is operating, so apply power to the unit.
4. Loosen adjusting lock-nut (32971) then turn adjusting screw (37090) clockwise until a reading of 6 noted on the slide (38220), at the end of the suction stroke. The pump is now set at maximum output.

Connect suction tubing or piping.

Flooded suction installations will prime immediately. Top mount installations will take a few seconds. Depending on the type of chemical being metered and the suction lift distance, it may be necessary to dampen the discharge valve area with the chemical being pumped in order to assist speedy priming.

CAUTION

ALWAYS READ WARNINGS ON CHEMICAL PACKAGE REGARDING HANDLING. WEAR SUITABLE EYE AND SKIN PROTECTION WHEN HANDLING THE CHEMICAL

After the pump is primed, reconnect discharge tubing or piping.

Reset the output adjustment screw (37090) by turning *counter-clockwise* to desired output. Output is calibrated in 6 (six) graduations, each one represented about 17% of the maximum output indicated on the data label. In addition, an output table (Figure #1) located on the pump housing will indicate the output at each of the six (6) settings.

NOTE: Since output will vary in proportion to actual discharge pressure and chemical viscosity, it is recommended that a field test be performed to determine exact pumping rate.

405 & 406 SERIES PUMPS	
SETTING #1:	9-oz. / .2-lt. per hour
SETTING #2:	20-oz. / .5-lt. per hour
SETTING #3:	31-oz. / .9-lt. per hour
SETTING #4:	42-oz. / 1.2-lt. per hour
SETTING #5:	53-oz. / 1.5-lt. per hour
SETTING #6:	61-oz. / 1.8-lt. per hour

WMS
'FLOW RATES AT 0-PSIG'

FIGURE #1
(example)

After proper setting has been achieved, tighten lock-nut (32971), against slide (38220), by turning *clockwise*.

Series 400, 450 and 500 are shipped with a packing set (group D) installed. The material is either neoprene or Teflon. Although each pump is tested extensively for loose packing, the packing sets will settle somewhat during initial operation. It is recommended that the packing set be checked and tightened 3 or 4 times during the first 14 days of operation. Follow steps 'B' thru 'E' (see page 10), then with a #471 spanner wrench or other suitable tool, tighten exposed packing nut by turning clockwise, (see Figure #2). Reinstall housing.

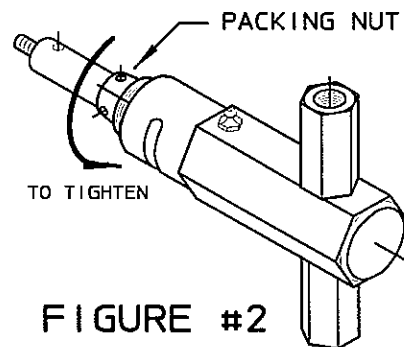

FIGURE #2

Series 450 are shipped with double check valve cartridges in the head assembly, each unit is supplied with a back check valve assembly, in order to help prevent backflow. Making sure pressure at the point of injection has been released, install the back check valve assembly into a 1/2" Tee. The end of the injection check valve should be in the main stream of the in fluent line. For large pipe diameters, a 6" check valve assembly is available to replace the standard back check valve assembly. **This extension can be cut to the proper length that will insure injection into the main stream. This will insure more rapid chemical dilution, thereby reducing the possibility of clogging.**

NOTE: Be sure to install the injection assembly for the Series 450 in a vertical position on the bottom side of the in fluent main. This will insure proper sealing of the injection assembly check valve. Be sure the arrow on the injection fitting is pointing upward.

If the line pressure of an installation fluctuates above the units rated pressure capability, install a pressure relief valve on the discharge side of the pump head.

NOTE: See page 5 for 'maximum operating pressure' rating for the various model pumps.

Series 400 chemical pumps with piston diameters up to and including 5/8" are shipped with pressure relief valves are standard. These valves are pre-set at 150 psi unless requested otherwise. Maximum pressure for PVC construction is 250 psi.

Relief valves must be ordered separately when used with Series 400 with 1" piston diameter units all Series 450 pumps and all Series 500 pumps.

The relief valve assemblies to the discharge side of the pump head by means of a 1/4" MNPT connection. This is usually accomplished by utilizing a 1/4" Tee on top of the last discharge valve. (See Figure #3).

In the event of high pressure or blockage in the discharge line, the relief valve will open, allowing the chemical being metered to be returned to supply by means of the 1/8" return line.

The relief valve pressure capabilities can be adjusted the following procedures:

1. Remove cap at back of valve.
2. Inside locate slotted screw.
3. Turn screw *clockwise* to increase maximum pressure.
4. Turn screw *counter-clockwise* to decrease maximum pressure.
5. Test with pressure gauge to insure proper value has been achieved. (250 psi is maximum for PVC).
6. Re-install the cap.

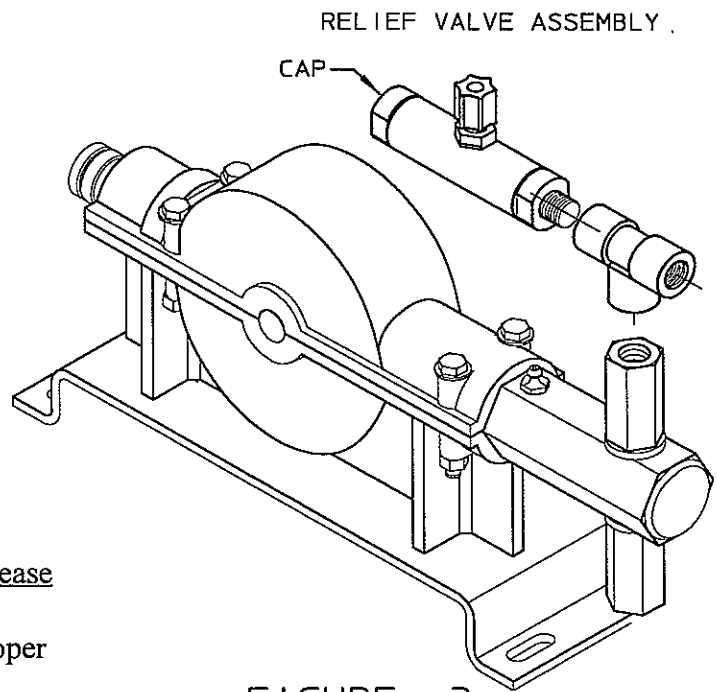

FIGURE #3

MAINTENANCE

Always wear protective clothing (protective gloves and safety glasses) when working on or near chemical metering pumps.

Never repair or move the chemical feeder (Series 400, 450, and 500) while operating. Always disconnect electrical current. Before handling the feeder, always allow sufficient time for the motor housing to cool off. **HANDLING THE FEEDER TOO SOON AFTER SHUTDOWN MAY CAUSE HAND BURNS. FOR SAFETY, USE PROTECTIVE GLOVES.**

Upon installation of Series 400, 450, and 500, and every month, it is recommended that the adjustment screw (37090) lock-nut (32971) and slide (38220) be sprayed with an appropriate lubricant (LPS#1, WD-40, or equivalent).

Every two months, extra grease should be applied to the head assembly through the 1/8" grease fitting (26811), and the cam bearing assembly area (Mobilith AW2 NGLI #2 extreme pressure grease or equivalent).

In order to expose the cam bearing assembly or to remove pump head assembly, the top pump housing (29246) must be removed. With a 7/16" ratchet or open-end wrench, remove the four (4) housing bolts (21406 and 21407).

When work is completed, re-install top housing, being careful not to apply excessive pressure to housing bolts.

Suction and discharge check valve assemblies should be cleaned every three to six months, depending on duty, and the type of chemical being pumped. (Check series 400, 450 and 500 parts diagrams).

Since Series 400 and 500 chemical pumps have stainless steel valves, flushing with an industrial solvent is recommended (Methyl Ethyl Keton (MEK) or equivalent). When handling solvents and other chemicals always note the manufacturers warning label.

Series 450 valves have PVC valves, a vinegar or mild muriatic acid solution is usually sufficient for a thorough cleaning.

PISTON, PACKING, AND PUMP HEAD REPLACEMENT

NOTE; BEFORE EFFECTING AND REPAIR, ALWAYS DISCONNECT ELECTRICAL POWER, BE SURE SUITABLE SKIN AND EYE PROTECTION IS WORN WHEN WORKING ON OR AROUND CHEMICAL PUMPS.

To replace the piston in the Series 400, 450, and 500:

- A. Disconnect all power to the chemical pump; disconnect suction and discharge piping and/or tubing making sure there is no pressure in the discharge line.
- B. Remove top housing (32246) by removing the four (4) housing bolts (21406 and 21407) with a 7/16" ratchet or open-end wrench.
- C. This will expose back of housing assembly, piston, cam bearing assembly, and slide arm assembly.
- D. Note small hole in back of piston; with 1/8" drive pin punch, or other suitable tool, insert through hole in piston. (See Figure #4). With strong *counter-clockwise* motion, apply pressure to break the tight screw fit between piston and slide are (38220).
- E. With one hand, turn complete head assembly until piston and head assembly is completely detached from slide arm.
- F. Using 1/8" drive pin punch, or equivalent, insert again in piston hole. Pull piston away from head assembly using short circular motions.
- G. To replace new piston, reverse the step list above ('F' thru 'B'), being careful to tighten the piston with sufficient force so as to reduce the possibility of loosening.

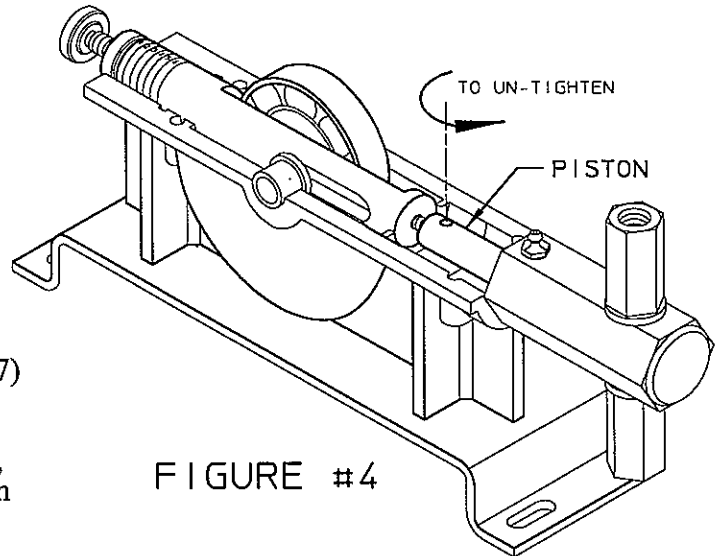

To replace packing and grease gland in the Series 400, 450 and 500:

(with piston sizes up to and including 5/8")

- H. Follow Steps 'A' thru 'F'.
- I. Remove packing nut, turning *counter-clockwise* using a #471 spanner wrench, or other suitable tool.
- J. After piston is removed, with a long small head slotted screwdriver, remove packing and grease gland.
- K. Grease gland is located between two (2) sets of packing in the pump head. Use extra care not to damage this part, as it is re-useable.
- L. Each packing set consists of a number of 'V' rings.
- M. When installing new packing, the end ring with the wide flat bottom is installed first. See figure #5 for correct order of internal pump head components.
- N. Each following ring locks over the one before it. **NOTE: Be sure to lightly tamp each ring as it is installed, to insure proper placement.**

- O. The grease gland is installed between two (2) rings in the set in the set. The first has a flat top, then the grease gland, then a ring with a flat bottom. When grease gland is installed, make sure it is properly lined up with the grease fitting (36811).
- P. The rings on either side of the grease gland should be noted in the packing set before assembly. (See Figure #5).
- Q. After packing set is completely installed, re-install packing nut with #471 spanner wrench, or other suitable tool.
- R. Do not over-tighten until piston is installed and pump head assembly is in place.
- S. To complete re-assembly, follow steps 'F' thru 'B' (reverse order).

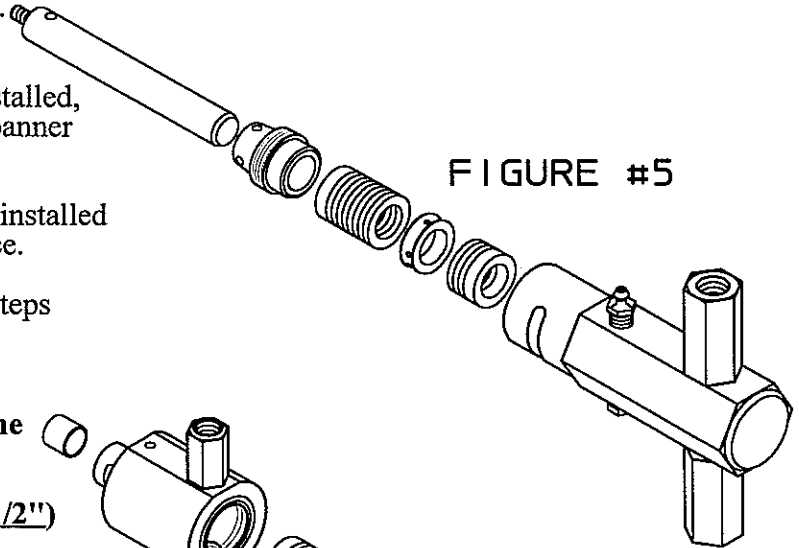

To replace packing and grease gland in the Series 400, 450, and 500:

(with piston sizes 1", 1-1/4", and 1-1/2")

- T. Removal and replacement of packing is accomplished from the front of the pump head. See Figure #6 for correct order of internal pump head components.
- U. Follow steps 'A' thru 'F'.
- V. Remove pump head cap by turning *counter-clockwise*, and packing compression spring.
- W. With packing exposed, remove piston using a long small head slotted screwdriver, then remove packing. **NOTE:** 1" piston pumps and larger do not utilize a grease gland.
- X. Once old packing is removed, install new packing set with rounded top, as opposed to wider flat bottom, first. (See figure #6). **NOTE:** Take extra care not to damage packing I.D. upon installation.
- Y. Re-install packing compression spring, PVC spacers, cap O'ring and head cap, turning cap as tight as possible with large adjustable wrench.
- Z. To complete re-assembly, follow steps 'F' thru 'B' (reverse order), **disregarding any reference to a packing nut as 1", 1-1/4" and 1-1/2" piston size units do not utilize this component.**

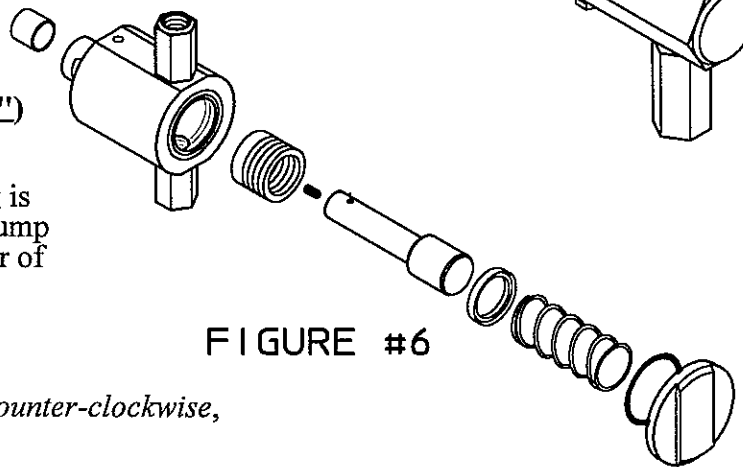

To replace pump head assembly in the Series 400, 450, and 500:

- AA. Simply follow steps 'B' thru 'F' listed above..

TROUBLE SHOOTING

PROBLEM	PROBABLE CAUSE	REMEDY
<p>PUMP WILL NOT PRIME AT START-UP</p>	<ol style="list-style-type: none"> 1. Too much pressure at discharge or pump head air locked 2. Check valves not sealing. 3. Output adjustment not set at maximum. 4. Suction lift capabilities exceeded. 	<ol style="list-style-type: none"> 1. Turn off all pressure valves, Disconnect outlet piping from discharge check valves. Dampen valve area with a few drops of solution. Set feeder capacity to maximum rate and apply power to feeder. When feeder is primed, reconnect all piping connections. 2. Dis-assemble, clean and check for deterioration. Re-assemble then prime. 3. Always prime pump with output set at maximum rated capacity. 4. Check suction lift distance (maximum recommended suction lift is 10 feet).
<p>PUMP MOTOR STALLS</p>	<ol style="list-style-type: none"> 1. Pumping against excessive pressure. 2. Low voltage to feeder. 	<ol style="list-style-type: none"> 1. Test pressure to determine if it exceeds feeder specifications. If so, consult factory or your dealer. 2. Make sure voltage of power source matches the voltage on the feeder specifications label. If not, contact your dealer or the factory for replacement.
<p>MOTOR RUNNING VERY HOT</p>	<ol style="list-style-type: none"> 1. Low voltage. 	<ol style="list-style-type: none"> 1. Power supply voltage should match voltage on feeder label. If not, contact your dealer or the factory for replacement.
<p>LOSS OF CHEMICAL RESIDUAL</p>	<ol style="list-style-type: none"> 1. Feeder setting to low. 2. Scale at injection point or suction or discharge valve assemblies. 	<ol style="list-style-type: none"> 1. Adjust to higher setting (feeder must be operating during adjustment). 2. Clean fouled parts with 8% muriatic acid or undiluted vinegar if PVC; MEK if steel or stainless steel.
<p>TOO MUCH CHEMICAL INJECTED OR METERED SOLUTION EXCEEDS PUMP ADJUSTMENT SETTING</p>	<ol style="list-style-type: none"> 1. Feeder setting to high. 2. Chemical in solution tank to rich. 3. Syphoning of chemical into in fluent main line due to vacuum or negative differential pressure. 	<ol style="list-style-type: none"> 1. Adjust to lower setting (feeder must be operating to during adjustment).. 2. Dilute chemical solution. NOTE; For chemical that reacts with water, it may be necessary to purchase a more diluted grade of chemical direct from chemical supplier. Where this is not possible, a lower capacity unit may be necessary. 3. Test for suction or vacuum at the injection point or if suction pressure exceeds discharge pressure. Injection point should be higher than the tank and pump. A back pressure valve may be required to increase differential pressure if the suction pressure is greater than the discharge pressure. Contact dealer for back pressure valve.
<p>UNIT LOSES PRIME AFTER START-UP</p>	<ol style="list-style-type: none"> 1. Leak in suction or discharge side of pump 2. Dirty check valve. 3. Ball checks not sealing properly. 4. Piston packing is loose or deteriorated. 5. Solution container allowed to run dry. 	<ol style="list-style-type: none"> 1. Examine suction and discharge connections for leaks in tubing or pipe fittings. 2. Inspect seat area and ball checks for scale deposits and clean. If deformity or deterioration is noted, replace part with proper material. 3. Check seat area and ball checks for scale deposits, and clean If deformity or deterioration is noted, replace part with proper material. 4. If installation is relatively new (less than six months), tighten packing. See figure #2 and installation instruction. If pump will still not meter or it leakage is noted, replace packing. (See page xx). NOTE; make sure material is compatible with the chemical being metered. 5. Refill container and prime.

SERIES 400 & 450 PART DIAGRAM

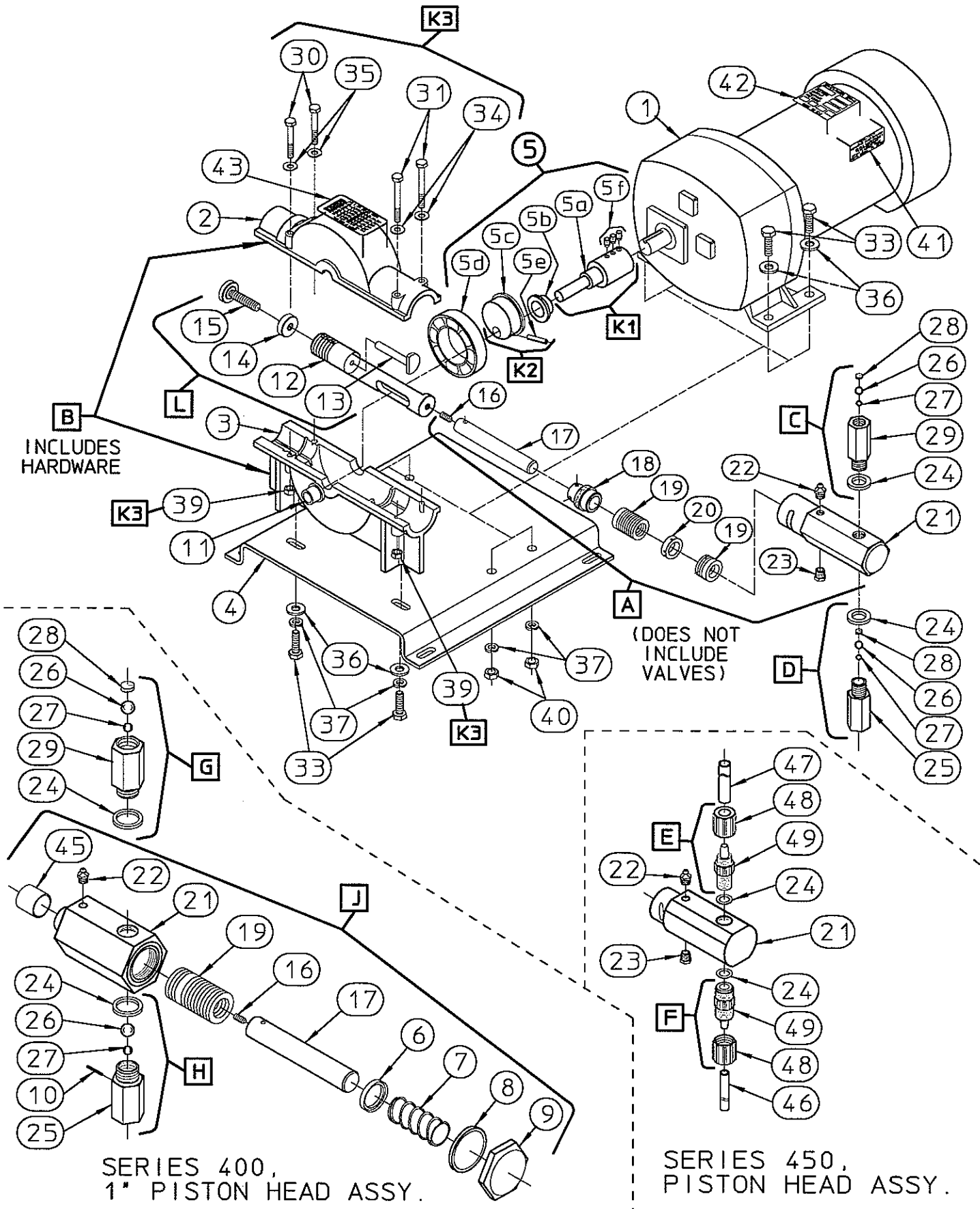

SERIES 400 & 450 PARTS LIST

ITEM	PART#	DESCRIPTION	QTY
1	J32749	MOTOR 30hp 115/230v 50/60hz.	1
	J32750	MOTOR 60hp 115/230v 50/60hz.	1
2	J29240	HOUSING, TOP	1
3	J29241	HOUSING, BOTTOM	1
4	J20723	BASE SIMPLEX	1
5	32648	SHAFT, CAM/BEAR. ASSY. (SIMPLEX)	REF
5a	37899	SHAFT, MIAN	1
5b	21965	BUSHING, .75"x.88"x.5"	1
5c	22263	CAM, MAIN BEARING	1
5d	20845	BALL BEARING	1
5e	33771	ROLL PIN	1
5f	D4844-31	SCREW, SET .25"-20 x.38"	3
6	* 38710	SPACER, PACKING 1"	1
7	* 38986	SPRING, compress. 1.0" PACK.	1
8	* 33082	O-RING, 1.0" PIST. VT	1
9	* 28840	CAP. HEAD 1.0" PIST. CRS	1
	* 28841	CAP. HEAD 1.0" PIST. 304SS (S)	1
10	* 33767	PIN, SUCTION CK. .50 SST	1
11	21972	BUSHING	1
12	38220	SLIDE	1
13	33764	PIN, SLIDE	1
14	32971	NUT, ADJ. SCREW LOCK	1
15	37090	SCREW, ADJUST.	1
16	37053	SCREW, .25"-28 x .5"	1
17	34180	PISTON .25" DIA. 303 SS	1
	34182	PISTON .38" DIA. 303 SS	1
	34184	PISTON .50" DIA. 303 SS	1
	34186	PISTON .63" DIA. 303 SS	1
	* 34188	PISTON 1.0" DIA. 303 SS	1
18	32972	NUT, PACKING .25" BORE	1
	32973	NUT, PACKING .38" BORE	1
	32974	NUT, PACKING .50" BORE	1
	32975	NUT, PACKING .63" BORE	1
19	33420	PACKING SET, .25" NEO (STD)	1
	33421	PACKING SET, .38" NEO (STD)	1
	33422	PACKING SET, .50" NEO (STD)	1
	33423	PACKING SET, .63" NEO (STD)	1
	* 33424	PACKING SET, 1.0" NEO (STD)	1
	33427	PACKING SET, .25" TEF (OPT S)	1
	33428	PACKING SET, .38" TEF (OPT S)	1
	33429	PACKING SET, .50" TEF (OPT S)	1
	33430	PACKING SET, .63" TEF (OPT S)	1
	* 33431	PACKING SET, 1.0" TEF (OPT S)	1
20	28380	GREASE GLAN .25" & .38" BORE PVC	1
	28381	GREASE GLAN .50" & .63" BORE PVC	1
21		SERIES 400:	1
	28821	HEAD, PUMP, .25 BORE 304SS (S-SER)	1
	28823	HEAD, PUMP, .38 BORE 304SS (S-SER)	1
	28825	HEAD, PUMP, .50 BORE 304SS (S-SER)	1
	28827	HEAD, PUMP, .63 BORE 304SS (S-SER)	1
	* 28828	HEAD, PUMP, 1.0 BORE CRS	1
	* 28829	HEAD, PUMP, 1.0 BORE 304SS (S-SER)	1
		SERIES 450:	1
	28834	HEAD, PUMP, .25 BORE PVC	1
	28835	HEAD, PUMP, .38 BORE PVC	1
	28836	HEAD, PUMP, .50 BORE PVC	1
	28837	HEAD, PUMP, .63 BORE PVC	1
22	26811	GEASE FITTING	1
23	26810	GREASE FITTING RELIEF	1
24	37305	SEAL RING PVC SMALL	2
	37306	SEAL RING PVC LARGE	2
	J27903	GASKET, TEF.	1
25	21274	VALVE, BODY, SUCTION	1
	* 21277	BODY, SUCTION CHECK .25" NPT	1
26	L1000500-ALA	VALVE BALL .38 DIA. (STD)	2
	L1000500-316	VALVE BALL .38 DIA. (OPT)	2
	* 20580	VALVE BALL .69 DIA. 316SS (STD)	2
	* 20578	VALVE BALL .69 DIA. TEF (OPT)	2
27	L1000400-ALA	VALVE BALL .25 DIA. (STD)	2
	L1000400-316	VALVE BALL .25 DIA. (OPT)	2
	* 20579	VALVE BALL .44 DIA. 316SS (STD)	2
	* 20577	VALVE BALL .44 DIA. TEF (OPT)	2
28	38988	SPRING, VALVE DISCH.	2
	* 38989	SPRING, VALVE DISCH.	2
29	21273	VALVE BODY, DISCHARGE	1
	* 21278	VALVE DISCHARGE CK. .25"NPT	1

* NOTE: SERIES 400 w/1" PISTON.

ITEM	PART#	DESCRIPTION	QTY
30	21406	BOLT, .25"-20 x 2"	2
31	21407	BOLT, .25"-20 x 2.2"	2
32	21411	BOLT, .31"-18 x 1"	6
34	42022	WASHER, .28" x .62" FLAT SST	2
35	42035	WASHER, 'D'	2
36	42053	WASHER, .31" FLAT	6
37	J42052	WASHER, .31" LOCK	6
39	32942	NUT, .25"-20 x .22 SST	4
40	J32944	NUT, .31"-18	4
41	25321	LABEL, CTI LOGO	1
42	60608	LABEL, DATA BLANK	1
43	30705	LABEL, DECAL (SET S405)	1
	30706	LABEL, DECAL (SET S409)	1
	30707	LABEL, DECAL (SET S413)	1
	30708	LABEL, DECAL (SET S417)	1
	30709	LABEL, DECAL (SET S425)	1
	30710	LABEL, DECAL (SET S429)	1
	30711	LABEL, DECAL (SET S433)	1
	30712	LABEL, DECAL (SET S437)	1
	30713	LABEL, DECAL (SET S441)	1
	30714	LABEL, DECAL (SET S445)	1
45	+21970	BUSHING BRONZE	1
46	00006	TUBING, SUCTION .44" OD PVC	1
47	J00012	TUBING, DISCHARGE .50" OD PPL	1
48	J24960	NUT, COUPLING	2
49	J41630	VALVE, HOUSING DOUBLE CHECK	1

* NOTE: SERIES 400 w/1" PISTON.

ITEM	PART#	DESCRIPTION	QTY
A		PISTON HEAD ASSEMBY -SERIES 400:	
	28932	PISTON HD. .25" BORE SST (SER-S)	1
	28931	PISTON HD. .38" BORE SST (SER-S)	1
	28930	PISTON HD. .50" BORE SST (SER-S)	1
	28929	PISTON HD. .63" BORE SST (SER-S)	1
		PISTON HEAR ASSEMBY -SERIES 450:	
	28924	PISTON HD. .25" BORE PVC	1
	28923	PISTON HD. .38" BORE PVC	1
	28922	PISTON HD. .50" BORE PVC	1
	28921	PISTON HD. .63" BORE PVC	1
B	29246	HOUSING SET ASSEMBY (SIMPLES)	1
C	41672	DISCHARGE CHECK VALVE ASSY.	1
D	41674	SUCTION CHECK VALVE ASSY.	1
E	J41669	DISCHARGE CK. VALVE ASSY. (2-BALL)	1
F	J41667	SUCTION CK. VALVE ASSY. (2-BALL)	1
G	+ 41673	DISCHARGE CK. VALVE ASSY. .50"FPT	1
H	+ 41675	SUCTION CK. VALVE ASSY. .50"FPT	1
J		PISTON HEAD ASSEMBLY (PISTON 1")	
	+ 28933	1"-BORE CRS	1
	+ 28934	1"-BORE 304 SST (SER. S)	1
L	38224	SLIDE ARM ASSY. (SIMPLEX)	1

* NOTE: FOR SEREIS 400 w/1" PISTON.

ITEM	PART#	DESCRIPTION	QTY
K1	J61530	KIT, MAIN SHAFT (SIMPLEX TEF)	REF
		ITEM # 5a 37899 'SHAFT'	1
		ITEM # 5f D4844-31 'SET SCREWS'	3
K2	J61531	KIT, MAIN BEARING CAM	REF
		ITEM # 5c 22263 'CAM'	1
		ITEM # 5e 33771 'ROLL PIN'	1
K3	J61532	KIT, HOUSING SET HARDWARE	REF
		ITEM # 30 21406 'BOLT' .25 x 2"	2
		ITEM # 31 21407 'BOLT' .25 x 2.2"	2
		ITEM # 34 42022 'WASHER'	2
		ITEM # 35 42035 'WASHER D'	2
		ITEM # 39 32942 'NUT' .25"	4

SERIES 500 PARTS DIAGRAM

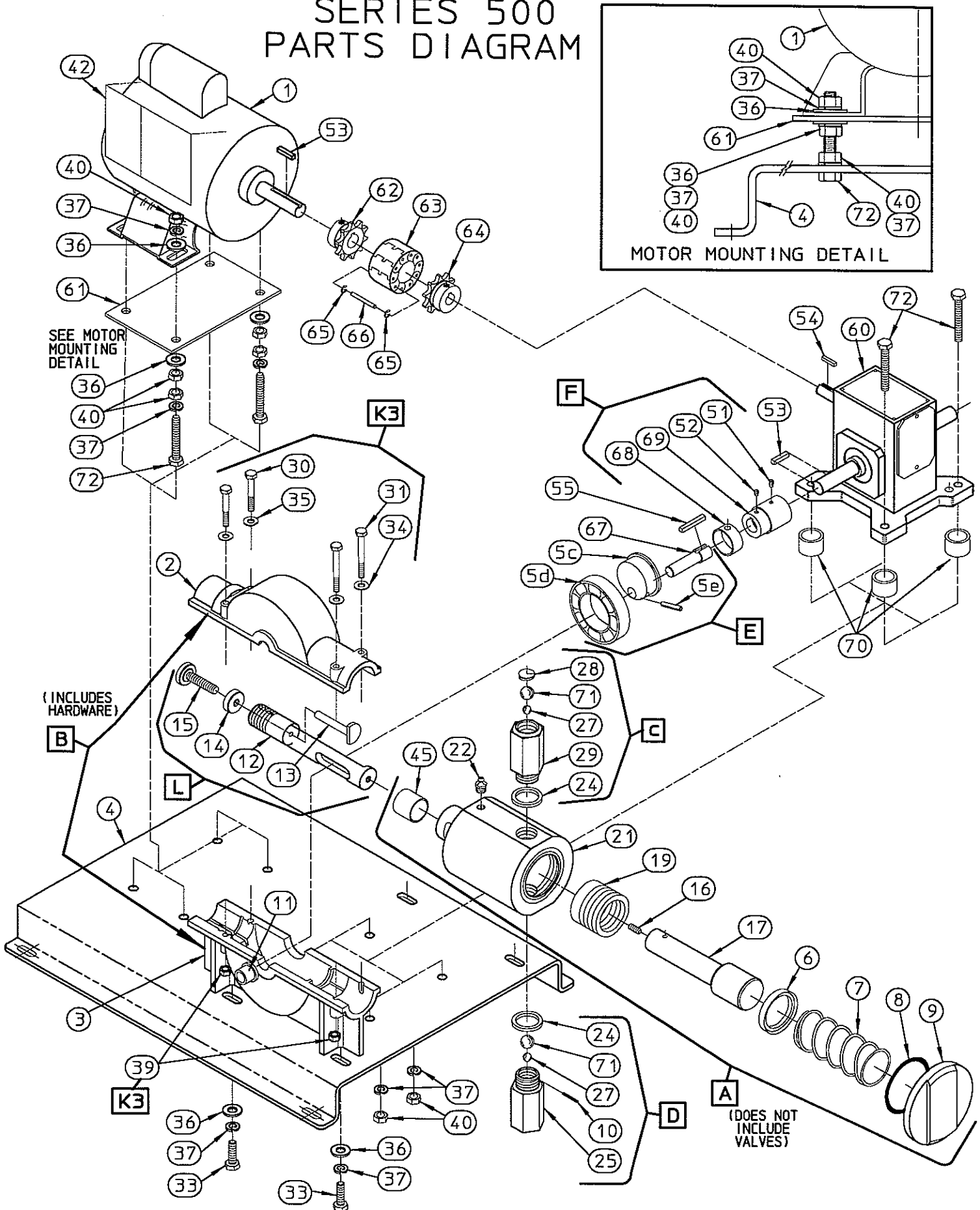

SEE MOTOR MOUNTING DETAIL

MOTOR MOUNTING DETAIL

(INCLUDES HARDWARE)

(DOES NOT INCLUDE VALVES)

SERIES 500 PARTS LIST

ITEM	PART#	DESCRIPTION	QTY
1	32590	MOTOR 300 1/2 3 OPEN 333	1
	32595	MOTOR 300 1/2 2 OPEN	
	32559	MOTOR 300 1/2 1 OPEN 50 HZ.	
	32560	MOTOR 300 1/2 1 OPEN BB	
2	J29240	HOUSING, TOP	1
3	J29241	HOUSING, BOTTOM	1
4	20704	BASE DUPLEX (D133 REDUCER)	1
5c	22263	CAM, MAIN BEARING	1
5d	20845	BALL BEARING	1
5e	33771	ROLL PIN	1
6	38710	SPACER, PACKING 1'	1
	38711	SPACER, PACKING 1.25'	
	38712	SPACER, PACKING 1.50'	
7	38987	SPRING	1
8	33082	O-RING, 1"PIST	1
9	28840	CAP, HEAD 1' CRS	1
	28841	CAP, HEAD 1' SS	
	28842	CAP, HEAD 1.25/1.50 CRS	
	28843	CAP, HEAD 1.25/1.50 SS	
10	33767	PIN, SUCTION	1
11	21972	BUSHING	1
12	38220	SLIDE	1
13	33764	PIN, SLIDE	1
14	32971	NUT, ADJ. SCREW LOCK	1
15	37090	SCREW, ADJUST.	1
16	37053	SCREW, 1/4-28 x .5"	1
17	34188	PISTON 1' DIA.	1
	34189	PISTON 1.25' DIA.	
	34190	PISTON 1.50' DIA.	
19	33424	PACKING SET, 1' NEO	1
	33425	PACKING SET, 1.25 NEO	
	33426	PACKING SET, 1.50 NEO	
	33431	PACKING SET, 1' TEFLON	
	33432	PACKING SET, 1.25 TEFLON	
21	28828	HEAD, PISTON, 1.0 (CRS)	1
	28829	HEAD, PISTON, 1.0 (SST)	
	28830	HEAD, PISTON, 1.25-1.5 (CRS)	
	28831	HEAD, PISTON, 1.25-1.5 (SST)	
22	26811	GEASE FITTING	1
24	37306	SEAL RING	2
25	21277	VALVE BODY, SUCTION	1
27	20579	VALVE BALL, .44"	2
28	38989	SPRING, VALVE BALL RETAIN.	1
29	21278	VALVE BODY, DISCHARGE	1
30	21406	BOLT, .25"-20 x 2"	2
31	21407	BOLT, .25"-20 x 2.2"	2
33	21411	BOLT, .31"-18 x 1"	2
34	42022	WASHER, .28" x .62" FLAT	2
35	42035	WASHER, 'D'	2
36	42053	WASHER, .31" FLAT	10
37	J42052	WASHER, .31" LOCK	14
39	J32942	NUT, .25"-20	4
40	J32944	NUT, .31"-18	16
42	60608	LABEL, DATA BLANK	1
45	21970	BUSHING	1
51	37047	SET SCREW #10-32 x .25"	1
52	37059	SET SCREW #10-32 x .15"	1
53	J30120	KEY, CAM SHAFT	2
54	J30126	KEY, .125"SQ. x .75-LG.	1
55	30121	KEY, CAM BEARING	1

ITEM	PART#	DESCRIPTION	QTY
60	J35913	REDUCER SPEED, 15:1	1
	J35916	REDUCER SPEED, 30:1	
	J35918	REDUCER, SPEED, 60:1	
61	34407	PLATE, MOTOR	1
62	39180	SPROCKET, MOTOR, .63	1
63	24976	COUPLING CHAIN	1
64	39181	SPROCKET, REDUCER, .50	1
65	36400	RETAIN. RING, COUPLING CHAIN	2
66	33765	PIN, COUPLING CHAIN	1
67	37892	SHAFT, MAIN (D133)	1
68	21974	BUSHING (D133)	1
69	24985	COUPLING, SHAFT (D133)	1
70	J38739	SPACER, REDUCER	4
71	20500	VALVE BALL, .94"	2
72	21424	BOLT, .31"-18 x 2"	8

ASSEMBLY KIT NUMBERS

ITEM	PART#	DESCRIPTION	QTY
A	28933	PISTON HEAD AS'Y 1.00"(CRS)	1
	28935	PISTON HEAD AS'Y 1.25"(CRS)	
	28937	PISTON HEAD AS'Y 1.50"(CRS)	
	28934	PISTON HEAD AS'Y 1.00"(SST)	
	28936	PISTON HEAD AS'Y 1.25"(SST)	
	28938	PISTON HEAD AS'Y 1.50"(SST)	
B	29247	HOUSING SET AS'Y(D133)	1
	+29248	HOUSING SET AS'Y(D133) DUPLEX	
C	41673	DISCHARGE CHECK VALVE AS'Y.	1
D	41675	SUCITON CHECK VALVE AS'Y.	1
E	22261	CAM/BEARING AS'Y. (D133)	1
F	25004	COUPLING AS'Y. (D133)	1
L	38224	SLIDE ARM AS'Y.	1
	+38225	SLIDE ARM AS'Y. DUPLEX	

+ NOTE: FOR DUPLEX MODELS ONLY.

HARDWARE REPLACEMENT KITS

ITEM	PART#	DESCRIPTION	QTY
K3	J61532	KIT, HOUSING HARDWARE SET	REF
30	21406	BOLT .25 x 2"-lg.	2
31	21407	BOLT .25 x 2.2"-lg.	2
34	42022	WASHER, FLAT	2
35	42035	D-WASHER, FLAT	2
39	32942	NUT, .25"-20 HEX	4

J32065.016,
6-K-0.