

Please read and save this Repair Parts Manual. Read this manual and the General Operating Instructions carefully before attempting to assemble, install, operate or maintain the product described. Protect yourself and others by observing all safety information. The Safety Instructions are contained in the General Operating Instructions. Failure to comply with the safety instructions accompanying this product could result in personal injury and/or property damage! Retain instructions for future reference.

SHURflo Heavy-Duty Cast Iron and Bronze Rotary Close-Coupled External Gear Pumps

Refer to form L-4082 for General Operating and Safety Instructions and Applicable Warranty.

Description

SHURflo self-priming, positive displacement, rotary external gear pumps provide a nearly pulseless flow. Standard models are mounted directly to NEMA frame AC Open Drip-Proof (ODP) motors using an easy-installation package, or as pump heads only for custom installations. Standard safety pressure relief valve that is included can be ported internally or externally. Single-phase motors are thermally overload protected; 3-phase ODP motors are not.

Uses: Handle a wide range of industrial, marine, agricultural and commercial applications where non-abrasive and non-particulated fluids compatible with pump wet-end construction component materials are pumped.

- Capacities up to 24.8 GPM.
- Maximum pressure to 125 PSI and working casing pressure to 200 PSI.
- Max. RPM: 1725.
- Suction lift to 19.5 ft.
- Mechanical seals (Viton or Buna) with carbon on ceramic faces with engineered flush chamber for internal or external flush to handle viscosities beyond 2000 SSU.
- Pumps with electric motors are configured to handle up to 500 SSU and 125 PSI at 1725 RPM or run at reduced speeds to handle a wide range of pump fluid viscosities and specific gravity up to 100,000 SSU. (Maximum torque loads are found in the performance chart.)
- Pumps can operate bi-directionally (reversible).
- Temperature ranges from -20° to 280° F.
- Standard adjustable pressure relief valves that can be internally or externally ported are standard.

BRONZE MODELS – Excellent for water-based fluids. Ryton PPS (Polyphenylene Sulfide) spur gears provide quiet operation and chemical compatibility. No metal-to-metal contact. Pumps also have 303 stainless steel shafts and carbon graphite bushings. Buna-N mechanical seal with temperature range of -20° to 210° F. Wet-end parts are constructed from bronze, brass, Ryton PPS, stainless steel (17-7, 303 and/or 18-8), vellumoid, graphite, carbon, ceramic, and Buna-N.

CAST IRON MODELS – Specifically designed to be used with oil-based fluids, not to be used with water-based fluids. Pumps include steel spur gears with steel shafts and cast iron shaft support. Viton mechanical seal has temperature range of 32° to 280° F. Wet-end parts are constructed from cast iron, steel, stainless steel (17-7, 303 and/or 18-8), vellumoid, carbon, ceramic and Viton.

REPAIR SEALS AND OPTIONS – Standard seals are Viton and Buna-N with carbon on ceramic faces. Standard seals can be located in the repair parts list pages in this manual. When switching between Viton and Buna-N mechanical seals, be sure to order the matching o-rings in the same material. These can be found in the repair parts list pages in this manual.

Optional Close-Coupled Gear Speed Reducers are available that mount directly between pump and motor to reduce pump speed for high viscosity or high specific gravity applications (See Appendix 2).

NOTE: This series of gear pumps is also available as pedestal models for custom installation. They are not equipped with motors.



WARNING: Do not use to pump flammable or explosive fluids such as gasoline, fuel oil, kerosene, etc. Do not use in flammable and/or explosive atmospheres. When pumping hazardous or dangerous materials, use only in a room or area designated for that purpose. For your protection, always wear proper clothing, eye protection, etc. in case of any malfunction. For proper handling techniques and cautions, contact your chemical supplier, insurance company and local agencies (fire dept., etc.). Failure to comply with this warning could result in personal injury and/or property damage.

SHURflo Heavy-Duty Cast Iron and Bronze Rotary Close-Coupled External Gear Pumps

Model Ordering Codes and Options

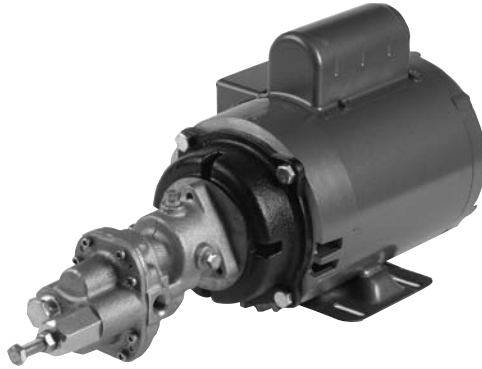

Example Model: GMCV5VB63 (2 HP ODP motor with >1.15 Service Factor*)
 (motor not supplied with pedestal pump)

(1) GM (2) C (3) V (4) 5 (5) V (6) B (7) 6 (8) 3

1st	2nd	3rd	4th	5th	6th	7th	8th
Mounting	Material	Seal (Mech)	Gear** Size: Ports	Options	Motor-Mounted Only		
					Brackets	HP	AC Type
GM: Gear Motor Mount*	C: Cast Iron B: Bronze	N: Buna-N V: Viton	2: 1/4" 3: 3/8" 4: 1/2" 5: 3/4" 6: 1"	V: Pressure Relief Valve (standard)	A: 56C B: 143/145TC C: 182/184TC	1: 1/3 2: 1/2 3: 3/4 4: 1 5: 1½ 6: 2 7: 3	"Blank": no code single phase ODP motor 3: 3 phase ODP motor T: 1 phase TEFC 3T: 3 phase TEFC

NOTE: Not all order code combinations (configurations) are standard models available from the manufacturer. Custom model configurations may require ordering standard components and/or optional parts that will need to be assembled by the customer.

Manufacturer reserves the right to change model order codes, standard models, specifications, and performance without notification.

(*) ODP motors have > 1.15 service factors. Due to service factor, it is recommended TEFC motors are oversized by one HP increment.

Pedestal Pumps are not supplied with a motor.

(**) Bronze models have Ryton PPS (Polyphenylene Sulfide) gears. Cast Iron models have steel gears.

Maximum motor speed is 1725 RPM.

Cast iron is not for use with water-based fluids.

Bronze Models GMBN2VA, GMBN2VA3, GMBN2VA33, GMBN3VA, GMBN3VA4, GMBN3VA43, GMBN4VA, GMBN4VA5, GMBN4VA53, GMBN5VB, GMBN5VB6, GMBN5VB63, GMBN6VC, GMBN6VC7, GMBN6VC73

Cast Iron Models GMCV2VA, GMCV2VA3, GMCV2VA33, GMCV3VA, GMCV3VA4, GMCN3VA43, GMCV4VA, GMCV4VA5, GMCV4VA53, GMCN5VB, GMCV5VB6, GMCV5VB63, GMCV6VC, GMCV6VC7, GMCV6VC73

Performance

Bronze Models	Cast Iron Models	*Port Size	Max. Input Torque in.-lbs.	Pump RPM	Suction** Lift (ft)	Free Flow GPM	HP	GPM Pumping 10 Wt. Oil at 70° F (500 SSU)											
								25 PSI GPM	HP	50 PSI GPM	HP	75 PSI GPM	HP	100 PSI GPM	HP	125 PSI GPM	HP		
GMBN2VA***	GMCV2VA***	1/4"	45	900	1.5	2.5	1/4	2.5	1/4	2.4	1/4	2.3	1/4	2.1	1/4	1.8	1/3		
GMBN2VA***	GMCV2VA***	1/4"	45	1200	2.2	3.3	1/4	3.3	1/4	3.2	1/4	3.1	1/3	2.9	1/3	2.6	1/2		
GMBN2VA***	GMCV2VA***	1/4"	45	1725	3.5	4.8	1/4	4.8	1/3	4.7	1/2	4.6	1/2	4.4	3/4	4.1	3/4		
GMBN2VA3	GMCV2VA3	1/4"	45	1725	3.5	4.8	1/4	4.8	1/3	4.7	1/2	4.6	1/2	4.4	3/4	4.1	3/4		
GMBN2VA33	GMCV2VA33	1/4"	45	1725	3.5	4.8	1/4	4.8	1/3	4.7	1/2	4.6	1/2	4.4	3/4	4.1	3/4		
GMBN3VA***	GMCV3VA***	3/8"	90	900	2.8	3.7	1/4	3.6	1/3	3.5	1/3	3.4	1/2	3.2	1/2	2.8	3/4		
GMBN3VA***	GMCV3VA***	3/8"	90	1200	5.7	4.9	1/4	4.8	1/3	4.7	1/2	4.6	1/2	4.4	3/4	4.0	3/4		
GMBN3VA***	GMCV3VA***	3/8"	90	1725	7.9	7.0	1/2	6.9	1/2	6.8	3/4	6.7	1	6.5	1	6.1	1½		
GMBN3VA4	GMCV3VA4	3/8"	90	1725	7.9	7.0	1/2	6.9	1/2	6.8	3/4	6.7	1	6.5	1	6.1	1½		
GMBN3VA43	GMCV3VA43	3/8"	90	1725	7.9	7.0	1/2	6.9	1/2	6.8	3/4	6.7	1	6.5	1	6.1	1½		
GMBN4VA***	GMCV4VA***	1/2"	90	900	5.1	5.6	1/3	5.5	1/3	5.4	1/2	5.3	3/4	5.0	1	4.5	1		
GMBN4VA***	GMCV4VA***	1/2"	90	1200	6.7	7.5	1/3	7.4	1/2	7.3	3/4	7.2	1	6.9	1	6.4	1½		
GMBN4VA***	GMCV4VA***	1/2"	90	1725	12.3	10.8	1/2	10.7	3/4	10.6	3/4	10.5	1	10.2	1½	9.7	1½		
GMBN4VA5	GMCV4VA5	1/2"	90	1725	12.3	10.8	1/2	10.7	3/4	10.6	3/4	10.5	1	10.2	1½	9.7	1½		
GMBN4VA53	GMCV4VA53	1/2"	90	1725	12.3	10.8	1/2	10.7	3/4	10.6	3/4	10.5	1	10.2	1½	9.7	1½		
GMBN5VB***	GMCV5VB***	3/4"	160	900	6.6	10.8	1/2	10.6	3/4	10.5	3/4	10.4	1	10.0	1	9.4	1½		
GMBN5VB***	GMCV5VB***	3/4"	160	1200	9.3	14.3	1/2	14.2	3/4	14.1	1	13.9	1½	13.5	1½	12.9	2		
GMBN5VB***	GMCV5VB***	3/4"	160	1725	15.2	20.6	3/4	20.5	1	20.3	1½	20.2	2	19.8	2	19.2	3		
GMBN5VB6	GMCV5VB6	3/4"	160	1725	15.2	20.6	3/4	20.5	1	20.3	1½	20.2	2	19.8	2	19.2	3		
GMBN5VB63	GMCV5VB63	3/4"	160	1725	15.2	20.6	3/4	20.5	1	20.3	1½	20.2	2	19.8	2	19.2	3		
GMBN6VC***	GMCV6VC***	1"	160	900	8.1	12.6	1/2	12.5	3/4	12.3	1	12.1	1	11.7	1½	11.1	1½		
GMBN6VC***	GMCV6VC***	1"	160	1725	19.5	24.8	3/4	24.7	1	24.5	1½	24.3	1½	23.9	2	23.3	2		
GMBN6VC***	GMCV6VC***	1"	160	1725	19.5	24.8	3/4	24.7	1	24.5	1½	24.3	2	23.9	3	23.3	3		
GMBN6VC7	GMCV6VC7	1"	160	1725	19.5	24.8	3/4	24.7	1	24.5	1½	24.3	2	23.9	3	23.3	3		
GMBN6VC73	GMCV6VC73	1"	160	1725	19.5	24.8	3/4	24.7	1	24.5	1½	24.3	2	23.9	3	23.3	3		

Test data taken on SAE 10 wt. oil at 70° F (500 SSU).

Performance in water will decrease by about 10%, and HP required will also be reduced by 10%. (Don't use water with Cast Iron.)

Pump performance when pump is new. As pump wears, the performance will decrease.

(*) Female NPT inlet and outlet (in inches) .

(**) Suction lift requires wetted gears and primed seal chamber.

(***) Motor not provided.

NOTES: Pumps with motors are HP rated to handle up to 500 SSU at 125 PSI and specific gravity of 1.0.

Max. PSI = 125

Max. Viscosity = 500 SSU at 1725 RPM with standard spur gears

Max. RPM = 1725

Max. Specific Gravity = 1.1 at 125 PSI, up to 1.6 at lower PSI & viscosity.

Max. Input Torque = See chart above.

Reverse Rotation = Pumps are equipped with pressure relief valves and can be run in reverse rotation; however, pressure relief valve will not function when pump is reversed unless pump relief valve cover is rotated 180°.

The pump relationship between volume (GPM), pressure (PSI), speed (RPM) and horsepower is shown on performance chart in Shurflo Motor Manual form L-4082. When pumping a more viscous liquid, a slower speed, a larger pipe size pump, and possibly a larger motor should be selected.

Manufacturer reserves the right to change performance without notification.

SHURflo Heavy-Duty Cast Iron and Bronze Rotary Close-Coupled External Gear Pumps

Specifications for Standard Pump Heads (motor not included)

Model	NEMA Motor Frame		Pump Shaft Dia.	Required Motor Shaft		PUMP CONSTRUCTION (Wet End)									Ship Wt. (lbs.)
	Required	Max. RPM		Motor Dia.	Motor Adapter	Port Size NPT	Body & Cover Castings	Pressure Relief Valve*	Gears	Bushing Shaft Material	Gasket	Seal & O-Rings**			
Bronze Models															
GMBN2VA	56C	1725	5/8 Spline	5/8 Keyed	CI	1/4	Bronze	Ryton	BR & SS	303 SS	CG	Vellumoid	Buna-N	10.5	
GMBN3VA	56C	1725	5/8 Spline	5/8 Keyed	CI	3/8	Bronze	Ryton	BR & SS	303 SS	CG	Vellumoid	Buna-N	11.2	
GMBN4VA	56C	1725	5/8 Spline	5/8 Keyed	CI	1/2	Bronze	Ryton	BR & SS	303 SS	CG	Vellumoid	Buna-N	12.8	
GMBN5VB	143/145TC	1725	20mm Spline	7/8 Keyed	CI	3/4	Bronze	Ryton	BR & SS	303 SS	CG	Vellumoid	Buna-N	19.8	
GMBN6VC	182/184TC	1725	20mm Spline	1 1/8 Keyed	CI	1	Bronze	Ryton	BR & SS	303 SS	CG	Vellumoid	Buna-N	22.8	
Cast Iron Models															
GMCV2VA	56C	1725	5/8 Spline	5/8 Keyed	CI	1/4	CI	Steel	Steel & SS	Steel	CI	Vellumoid	Viton	11.2	
GMCV3VA	56C	1725	5/8 Spline	5/8 Keyed	CI	3/8	CI	Steel	Steel & SS	Steel	CI	Vellumoid	Viton	12.6	
GMCV4VA	56C	1725	5/8 Spline	5/8 Keyed	CI	1/2	CI	Steel	Steel & SS	Steel	CI	Vellumoid	Viton	13.4	
GMCV5VB	143/145TC	1725	20mm Spline	7/8 Keyed	CI	3/4	CI	Steel	Steel & SS	Steel	CI	Vellumoid	Viton	18.7	
GMCV6VC	182/184TC	1725	20mm Spline	1 1/8 Keyed	CI	1	CI	Steel	Steel & SS	Steel	CI	Vellumoid	Viton	19	

Ryton = PPS (Polyphenylene Sulfide) SS = Stainless Steel CG = Carbon Graphite CI = Cast Iron BR = Brass

(*) Bronze models are made of brass and/or bronze and stainless steel (17-7, 303 and/or 18-8). Cast Iron models are made of cast iron, steel and stainless steel (17-7, 303 and/or 18-8).

(**) Made from 18-8 SS and carbon on ceramic. O-rings are Buna-N or Viton to match the seal type.

NOTES: Dimensions are in inches unless otherwise noted.

Pump ships complete with all drive components, less motor.

Manufacturer reserves the right to change specifications without notification.

Specifications for Standard Motor-Mounted Models (motor included)

Model	AC Motor		NEMA Frame	Motor Voltage	Amps	PH*	Motor RPM	Pump Shaft Size Dim.	Motor Shaft Dim.	Motor Adapter	PUMP CONSTRUCTION (Wet End)							Ship Wt. (lbs.)	
	HP	Motor Type*									Port Size NPT	Body & Cover Castings	Pressure Relief Valve**	Gears	Bushing Shaft Material	Gasket	Seal & O-Rings***		
Bronze Models																			
GMBN2VA3	3/4	ODP	56C	115/230	11.2/5.6	1	1725	5/8 Spline	5/8 Keyed	CI	1/4	Bronze	Ryton	BR & SS	303 SS	CG	Vellumoid	Buna-N	37.5
GMBN2VA33	3/4	ODP	56C	230/460	2.6/1.3	3	1725	5/8 Spline	5/8 Keyed	CI	1/4	Bronze	Ryton	BR & SS	303 SS	CG	Vellumoid	Buna-N	35.5
GMBN3VA4	1	ODP	56C	115/230	13.2/6.6	1	1725	5/8 Spline	5/8 Keyed	CI	3/8	Bronze	Ryton	BR & SS	303 SS	CG	Vellumoid	Buna-N	45.2
GMBN3VA43	1	ODP	56C	230/460	3.2/1.6	3	1725	5/8 Spline	5/8 Keyed	CI	3/8	Bronze	Ryton	BR & SS	303 SS	CG	Vellumoid	Buna-N	39.2
GMBN4VA5	1 1/2	ODP	56C	115/230	18.4/9.2	1	1725	5/8 Spline	5/8 Keyed	CI	1/2	Bronze	Ryton	BR & SS	303 SS	CG	Vellumoid	Buna-N	51.8
GMBN4VA53	1 1/2	ODP	56C	230/460	4.8/2.4	3	1725	5/8 Spline	5/8 Keyed	CI	1/2	Bronze	Ryton	BR & SS	303 SS	CG	Vellumoid	Buna-N	41.8
GMBN5VB6	2	ODP	143/145TC	115/230	21.2/10.6	1	1725	20mm Spline	7/8 Keyed	CI	3/4	Bronze	Ryton	BR & SS	303 SS	CG	Vellumoid	Buna-N	64.8
GMBN5VB63	2	ODP	143/145TC	230/460	6.0/3.0	3	1725	20mm Spline	7/8 Keyed	CI	3/4	Bronze	Ryton	BR & SS	303 SS	CG	Vellumoid	Buna-N	54.8
GMBN6VC7	3	ODP	182/184TC	230	14.7	1	1725	20mm Spline	1 1/8 Keyed	CI	1	Bronze	Ryton	BR & SS	303 SS	CG	Vellumoid	Buna-N	92.8
GMBN6VC73	3	ODP	182/184TC	230/460	8.2/4.1	3	1725	20mm Spline	1 1/8 Keyed	CI	1	Bronze	Ryton	BR & SS	303 SS	CG	Vellumoid	Buna-N	80.8
Cast Iron Models																			
GMCV2VA3	3/4	ODP	56C	115/230	11.2/5.6	1	1725	5/8 Spline	5/8 Keyed	CI	1/4	CI	Steel	Steel & SS	Steel	CI	Vellumoid	Viton	38.2
GMCV2VA33	3/4	ODP	56C	230/460	2.6/1.3	3	1725	5/8 Spline	5/8 Keyed	CI	1/4	CI	Steel	Steel & SS	Steel	CI	Vellumoid	Viton	36.2
GMCV3VA4	1	ODP	56C	115/230	13.2/6.6	1	1725	5/8 Spline	5/8 Keyed	CI	3/8	CI	Steel	Steel & SS	Steel	CI	Vellumoid	Viton	46.6
GMCV3VA43	1	ODP	56C	230/460	3.2/1.6	3	1725	5/8 Spline	5/8 Keyed	CI	3/8	CI	Steel	Steel & SS	Steel	CI	Vellumoid	Viton	40.6
GMCV4VA5	1 1/2	ODP	56C	115/230	18.4/9.2	1	1725	5/8 Spline	5/8 Keyed	CI	1/2	CI	Steel	Steel & SS	Steel	CI	Vellumoid	Viton	52.4
GMCV4VA53	1 1/2	ODP	56C	230/460	4.8/2.4	3	1725	5/8 Spline	5/8 Keyed	CI	1/2	CI	Steel	Steel & SS	Steel	CI	Vellumoid	Viton	42.4
GMCV5VB6	2	ODP	143/145TC	115/230	21.2/10.6	1	1725	20mm Spline	7/8 Keyed	CI	3/4	CI	Steel	Steel & SS	Steel	CI	Vellumoid	Viton	63.7
GMCV5VB63	2	ODP	143/145TC	230/460	6.0/3.0	3	1725	20mm Spline	7/8 Keyed	CI	3/4	CI	Steel	Steel & SS	Steel	CI	Vellumoid	Viton	53.7
GMCV6VC7	3	ODP	182/184TC	230	14.7	1	1725	20mm Spline	1 1/8 Keyed	CI	1	CI	Steel	Steel & SS	Steel	CI	Vellumoid	Viton	89.0
GMCV6VC73	3	ODP	182/184TC	230/460	8.2/4.1	3	1725	20mm Spline	1 1/8 Keyed	CI	1	CI	Steel	Steel & SS	Steel	CI	Vellumoid	Viton	77.0

Ryton = PPS (Polyphenylene Sulfide) SS = Stainless Steel CG = Carbon Graphite CI = Cast Iron ODP = Open Drip-Proof BR = Brass

(*) Motors are rated at 60 hertz only. Single-phase motors are thermally overload protected and three-phase motors are not thermally protected. Thermal overloads may be manual or automatic.

(**) Bronze models are made of brass and/or bronze and stainless steel (17-7, 303 and/or 18-8). Cast Iron models are made of cast iron, steel and stainless steel (17-7, 303 and/or 18-8).

(***) Made from 18-8 SS and carbon on ceramic. O-rings are Buna-N or Viton to match the seal type.

NOTES: Dimensions are in inches unless otherwise noted.

Driver data is subject to change without notice; see label on driver for specifications and wiring information.

Manufacturer reserves the right to change specifications without notification.

Bronze Models GMBN2VA, GMBN2VA3, GMBN2VA33, GMBN3VA, GMBN3VA4, GMBN3VA43, GMBN4VA, GMBN4VA5, GMBN4VA53, GMBN5VB, GMBN5VB6, GMBN5VB63, GMBN6VC, GMBN6VC7, GMBN6VC73
Cast Iron Models GMCV2VA, GMCV2VA3, GMCV2VA33, GMCV3VA, GMCV3VA4, GMCN3VA43, GMCV4VA, GMCV4VA5, GMCV4VA53, GMCN5VB, GMCV5VB6, GMCV5VB63, GMCV6VC, GMCV6VC7, GMCV6VC73

Dimensions (inches)

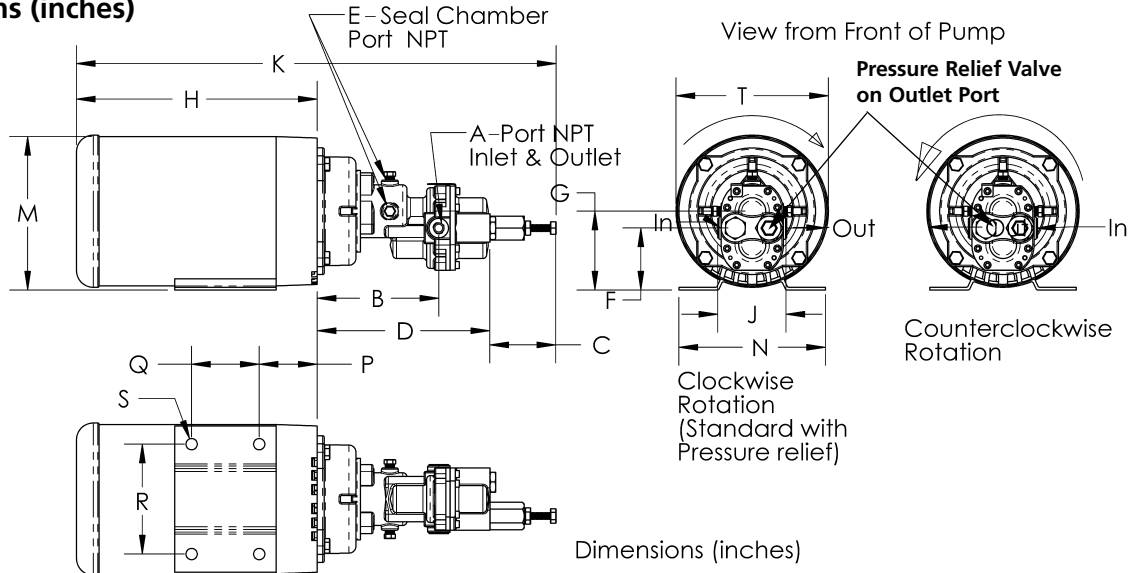

Figure 1

Model Numbers	Port						Dimensions (in inches)										
	A*	B	C	D	E*	F	G	H***	J	K**	M**	N**	P**	Q**	R**	S**	T**
GMBN2VA, GMCV2VA, GMBN2VA3	1/4	5.87	2.75	8.20	1/8	2.85	3.50	10.56	2.72	21.51	6.32	6.50	2.63	3.00	4.88	0.34	6.59
GMBN2VA33, GMCV2VA3, GMCV2VA33																	
GMBN3VA, GMCV3VA, GMBN3VA4	3/8	5.40	2.93	7.60	1/8	2.75	3.50	10.88	2.96	21.41	6.32	6.50	2.63	3.00	4.88	0.34	6.59
GMBN3VA43, GMCV3VA4, GMCV3VA43																	
GMBN4VA, GMCV4VA, GMBN4VA5	1/2	5.59	2.94	7.97	1/8	2.75	3.50	11.88	3.48	22.79	6.32	6.50	2.63	3.00	4.88	0.34	6.59
GMBN4VA53, GMCV4VA5, GMCV4VA53																	
GMBN5VB, GMCV5VB, GMBN5VB6	3/4	6.00	3.16	8.51	1/8	2.50	3.50	12.69	3.92	24.36	6.81	7.00	2.25	4.00	5.00	0.34	6.59
GMBN5VB63, GMCV5VB6, GMCV5VB63																	
GMBN6VC, GMCV6VC, GMBN6VC7	1	7.04	3.17	9.67	1/8	3.50	4.50	14.13	4.04	26.97	8.75	9.00	2.75	4.50	7.50	0.41	8.47
GMBN6VC73, GMCV6VC7, GMCV6VC73																	

(*) Standard NPT (female) pipe thread (in inches).

(**) This dimension may vary due to motor manufacturer's specifications.

(***) Length of motor from C-face to back. This dimension may vary due to motor manufacturer's specifications.

NOTE: All dimensions have a tolerance of (+ or -) 1/8".

Dimensions may vary based on motor manufacturer.

Manufacturer reserves the right to change dimensions without notification.

Gear Part Numbers and Dimensions (in inches)

Gear-Ryton (PPS) Black Spur	13879	21137	12764	21136	13883
Gear-Steel Spur	21456	21157	21458	21459	21460
Gear Outside Diameter (OD)	1.50	1.75	1.75	2.33	2.33
Gear Width (W)	0.75	0.88	1.25	1.25	1.50
Shaft Size (S)	0.50	0.63	0.63	0.79	0.79

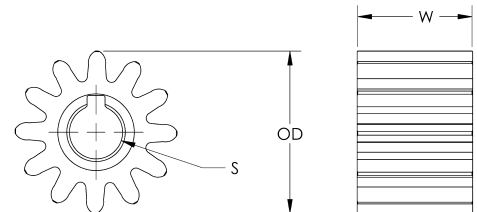

Ryton PPS (Polyphenylene Sulfide)

NOTE: Manufacturer reserves the right to change dimensions without notification.

Figure 2 - Gear Identification and Dimension Chart

SHURflo Heavy-Duty Cast Iron and Bronze Rotary Close-Coupled External Gear Pumps

⚠ WARNING

Check motor. It may be equipped with an automatic resetting thermal protector and may restart unexpectedly (see specifications chart). Protector tripping is an indication of motor overloading as a result of operating the pump at too high a pressure (over 125 PSI), too high of viscosity, too high of specific gravity, excessively high or low voltage, inadequate wiring, incorrect motor connections, too small a motor (sized incorrectly, not enough HP), or a defective motor or pump.

Do not handle pump with wet hands or when standing in water. Failure to follow the General Safety Information and all warnings could result in fatal electrical shock!

Assembly

(If pump and motor are pre-assembled, skip assembly.)

1. Two styles of motor to pump shaft couplers are manufactured but only one is shipped with each pump. See Figures 3 & 4 to identify which coupler you have.
2. Apply anti-seize compound to the entire length of the motor shaft and drive coupling spline teeth.
3. If you have a Type B coupler, install the rubber plug (See Figure 4) into the bottom of the motor shaft bore in the drive coupling.
4. Align the keyways of motorshaft and coupling, then install the key (See Figure 3 or 4). Slide the drive coupling onto the motor shaft as far as it will go.

NOTE: Some models are supplied with a bushing and extra key (not shown), which converts the drive coupling from a 7/8" motor shaft bore to a 5/8" motor

shaft bore. Install bushing and key into the motor shaft bore of the coupling if needed.

5. Install the set screws into the coupler and tighten the set screws securing the coupler, key and motor shaft together. For Type B collar, ensure the collar set screws line up over the key and it is flush with the back edge of the coupling prior to tightening (See Figure 4).
6. The coupling is now ready for final pump motor assembly.
7. Make sure the splines are coated with anti-seize compound or grease. Slide the male spline shaft on the pump head into the female spline now mounted on the motor shaft. The pump head will pivot on the motor.
8. Secure the pump to the motor with four bolts.
9. The unit is ready for operation.

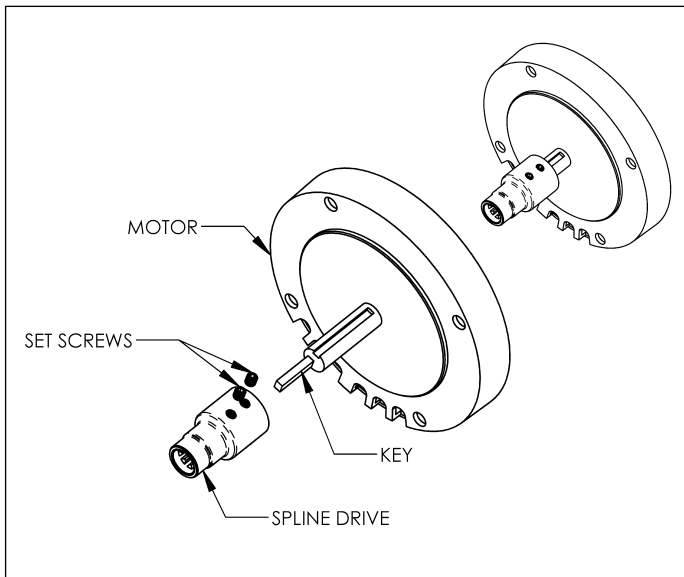

Figure 3 - Type A Motor Shaft Coupler

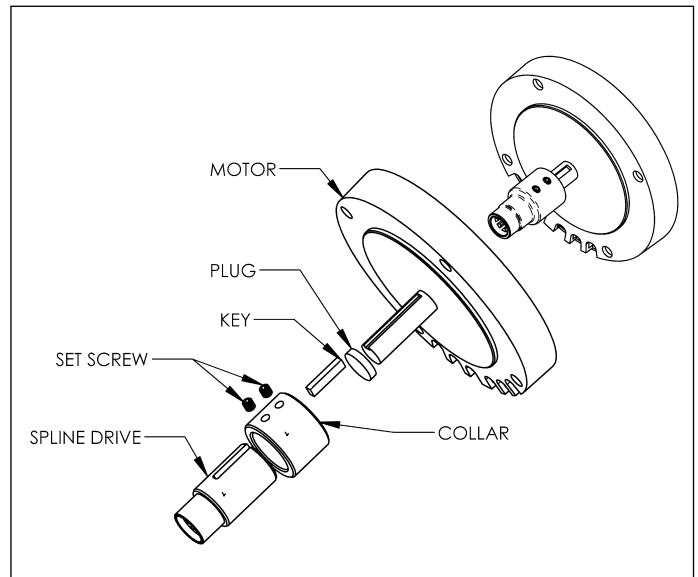

Figure 4 - Type B Motor Shaft Coupler

Bronze Models GMBN2VA, GMBN2VA3, GMBN2VA33, GMBN3VA, GMBN3VA4, GMBN3VA43, GMBN4VA, GMBN4VA5, GMBN4VA53, GMBN5VB, GMBN5VB6, GMBN5VB63, GMBN6VC, GMBN6VC7, GMBN6VC73

Cast Iron Models GMCV2VA, GMCV2VA3, GMCV2VA33, GMCV3VA, GMCV3VA4, GMCN3VA43, GMCV4VA, GMCV4VA5, GMCV4VA53, GMCN5VB, GMCV5VB6, GMCV5VB63, GMCV6VC, GMCV6VC7, GMCV6VC73

Installation

IMPORTANT: In any installations where property damage and/or personal injury can occur when the pump is not operating due to power outages, discharge line freezing, or any other reason, a back-up system(s) and/or warning system(s) should be used.

In order to safely use this product, familiarize yourself with this pump and also with the liquid (chemical, etc.) that is going to be pumped through the unit. This pump is not suitable for many liquids.

1. Locate the pump as close to the liquid source as possible, making the suction line as short and direct as possible.

PIPING

SUCTION

2. Avoid excessive lengths or number of fittings and bends in the suction line.
3. Attach suction line to suction inlet.
4. It is recommended that same size pipe as pump ports be used or, in cases requiring lengthy piping, the next larger size pipe be used.
5. If suction lift is greater than what is indicated in the performance chart, attach a foot valve below liquid level at end of suction line to ensure positive priming. Also note: If fluid specific gravity is greater than 1.4 or viscosity greater than 500 SSU, a foot valve is also recommended.

NOTE: If a foot valve (or check valve) is not used in the suction line, it may be necessary to refill the pump every time the unit is stopped and you wish to restart the pump. This depends on the length of time between starts and whether or not the gears are wet enough to close cavities to affect a prime.

6. If solid contaminates are suspected in a liquid, place a filter in the suction line.

7. Be certain all suction piping connections are airtight.

NOTE: Assure airtight pipe connections with the use of a pipe joint sealant.

DISCHARGE

8. Attach discharge piping to the discharge outlet.

WARNING *Support pump and piping during assembly and after installation. Failure to do so may cause piping to break, pump to fail, motor bearing failures, etc., all of which can result in property damage and/or personal injury.*

NOTE: Should the pump need to be self-draining, the pump head should be mounted in the vertical position with the suction port facing down. When pumping high viscosity fluids, the vertical position can be used with the suction port facing up and the pump mounted under the source. Increasing the suction pipe size and eliminating bends and elbows also assists in pumping high viscosity fluids. Max. viscosity is 500 SSU at 1725 RPM.

9. If a shut-off valve or handgun is required in discharge line, provide a pressure relief valve for pump protection.

WARNING *Shutting off discharge without providing pressure relief can cause extreme over-pressure which can result in pump and/or motor failure. Do not exceed 125 PSI pump or system pressure.*

10. Operation under shut-off discharge conditions will overheat and damage pump.

NOTE: Globe valves or other restrictive valves should not be used as shut-off mechanism as they are restrictive in nature and will seriously affect pump performance.

11. After all piping and controls (not supplied with unit) have been installed, unit is ready for operation.

Operation

CAUTION *Do not run pump dry, as permanent damage to the pump gears, seal, and bearings will result. Suction pressure should never be greater than the discharge pressure.*

1. All pumps must be primed before start-up and the seal chamber needs to be filled (See Figure 5). Never operate a pump unless it is secured to a solid foundation and all safety shields are installed.

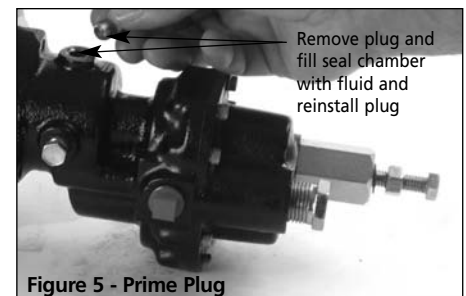

Figure 5 - Prime Plug

- Upon start-up, maintain a minimum of 15 PSI (1 BAR) operating pressure on the pump. This will allow any remaining air to be driven from the seal chamber and will ensure liquid circulation to the mechanical seal.
2. Gear pumps are built to very close tolerances and this tolerance must not be altered. The liquids must, therefore, be free of all abrasives. Sand, silt, wettable powders, etc. must be avoided.

NOTE: Cast iron pumps are for oil-based fluids only.

3. When pumping a more viscous (beyond 500 SSU) liquid; a slower speed, a larger pipe size pump, and possibly a large motor should be selected.

NOTE: See performance chart for Max. Torque.

4. Recheck motor and pump rotation. Proper pump rotation is clockwise (CW) looking at the front of the pump when pressure relief valve is

SHURflo Heavy-Duty Cast Iron and Bronze Rotary Close-Coupled External Gear Pumps

Operation (continued)

installed by manufacturer (See Figure 1).

5. On all standard models, pressure relief valve is always on discharge side (See Figure 1).

PRESSURE RELIEF VALVE

6. Standard model rotary gear pumps are supplied with a built-in internal pressure relief valve (can be externally ported). The valve may be adjusted and used to set system operating pressure, or used as a system pressure relief valve to prevent pump and motor damage that can occur when discharge line is closed off. This relief valve is not factory set. Extended operation (over one minute) under shut-off conditions could cause pump to overheat, leak, and damage itself or overload motor.
7. To increase the pressure relief valve pressure setting, loosen lock nut (See Figure 12, Ref. No. 37), then turn the set screw (See Figure 12, Ref. No. 36) in (clockwise). Turning the set screw out (counterclockwise) will reduce the pressure setting. When desired pressure is achieved, tighten lock nut and reinstall protective cap (See Figure 6).

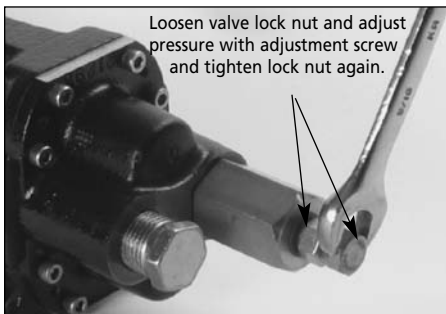

Figure 6 - Pressure Relief Valve Adjustment

8. The pressure relief valve can be converted to an external relief. This will allow the relief to dump back to tank and allow longer periods of relief without pump damage.

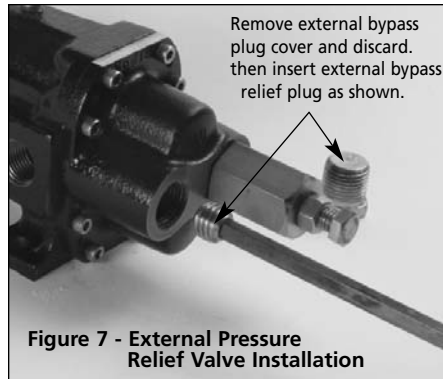

Figure 7 - External Pressure Relief Valve Installation

However, this is not a full-line relief valve, and in cases where frequent extended relief valve operation is anticipated, a full-line external relief valve should be piped in the discharge line and connected either back to the tank or well downstream of the pump suction inlet (See Figure 7).

9. To convert the relief valve to external relief, remove the NPT pipe plug from the pump cover (See Figure 12, Ref. No. 36) and discard. This plug is next to the relief valve. In the bottom of the NPT hole, there is a second drilled and tapped hole. An optional external bypass plug (See Figure 12, Ref. No. 39 included) should be inserted in this hole and bottomed out. The open NPT port must now be piped back to the tank or well downstream of the pump suction (See Figure 7).
10. Standard models are equipped with pressure relief valves, and the pump can be run in reverse, however, the pressure relief valve will not function. For continuous reverse rotation, the cover plate must be rotated 180°. This is accomplished by removing the eight cover plate screws, rotating the cover plate, and reattaching the screws. The pressure relief valve should now be on the opposite side. This will allow operation of the pump with a functioning pressure relief valve in reverse rotation.

GEAR PUMP GASKET ADJUSTMENT FOR TEMPERATURE (See Appendix 1)

11. For operation in fluid temperatures above 120° F, bronze pump models must have the gasket thickness adjusted (not necessary for cast iron models). Use Appendix 1 to identify pump, temperature and gasket recommendations for adjusting the cover clearance prior to operation in elevated temperatures or viscosities above 500 SSU.

CAUTION Failure to adjust pump cover clearances for operating temperatures above 120° F will result in severe pump and/or motor damage.

NOTE: When pumping fluids of high viscosity (>500 ssu), the required torque and HP can be reduced by adding a gasket for increased gear clearance.

MECHANICAL SEAL FLUSH INSTALLATION OPTIONS

12. These bronze and cast iron pumps are equipped with mechanical seals and have been designed with flush ports because mechanical seals require cooling lubrication for long life.
 - a. For fluids with viscosities less than 2000 SSU, a flush is not necessary, but the seal cavity must be pre-filled with either the operating fluid or a neutral fluid. This is to ensure seal cooling and lubrication during start-up (See Figure 5).

CAUTION Failure to provide initial seal prime can result in the mechanical seal overheating with resulting repair costs.

- b. For high viscosity fluids, a flush will be necessary. The seal must be cooled and lubricated by a fluid. In the case of high viscosity fluids, due to the precision clearances between the gear teeth and the bronze or cast iron body, highly viscous fluids will not be able to adequately relieve the air

Bronze Models GMBN2VA, GMBN2VA3, GMBN2VA33, GMBN3VA, GMBN3VA4, GMBN3VA43, GMBN4VA, GMBN4VA5, GMBN4VA53, GMBN5VB, GMBN5VB6, GMBN5VB63, GMBN6VC, GMBN6VC7, GMBN6VC73

Cast Iron Models GMCV2VA, GMCV2VA3, GMCV2VA33, GMCV3VA, GMCV3VA4, GMCN3VA43, GMCV4VA, GMCV4VA5, GMCV4VA53, GMCN5VB, GMCV5VB6, GMCV5VB63, GMCV6VC, GMCV6VC7, GMCV6VC73

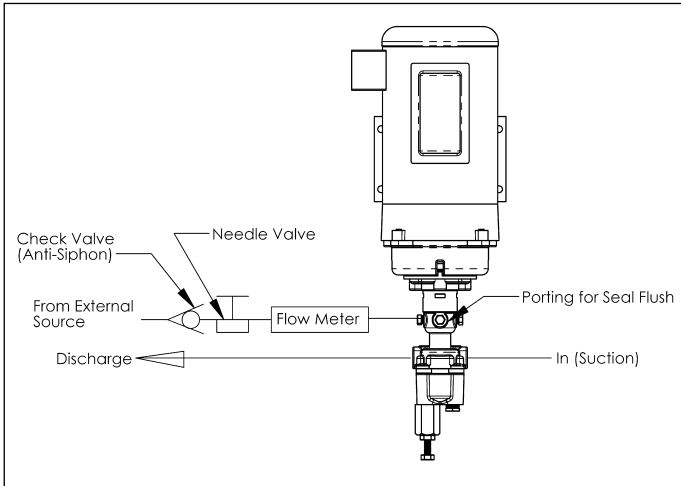

Figure 8 - External Flush

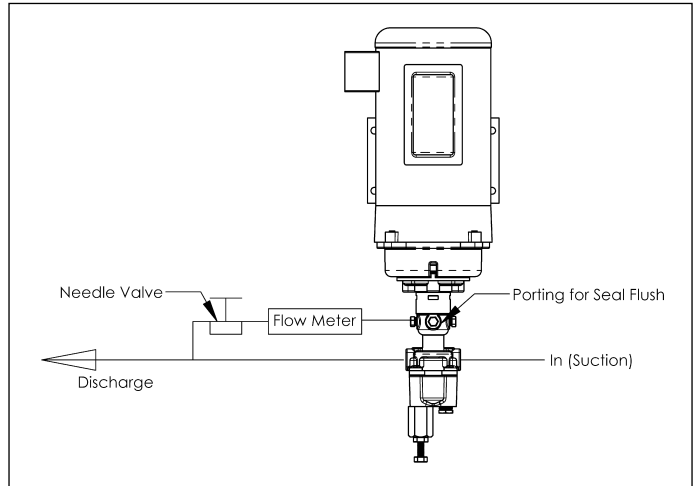

Figure 9 - Internal Flush

in the seal cavity on start-up. The dry running of a mechanical seal will cause rapid failure. A flush must be provided for fluids with a viscosity of greater than 2000 SSU.

CAUTION Pumping fluids with viscosities greater than 2000 SSU requires flushing the seal chamber during operation, otherwise seal damage will occur.

EXTERNAL FLUSH

An external flush system is typically recommended for applications where crystallization build-up on the seal is possible. Some dilution of the working material must be acceptable to use an external flush system.

The external flush system (See Figure 8 for typical installation) is commonly used with liquids where city water can be used as the neutral flush fluid. City water is taken from an external source such as a tap, hose, or special plumbing fixture and is regulated into the seal cavity by means of a needle valve and flow meter. Use of an anti-siphon check valve is required.

WARNING It is essential that an anti-siphon check valve be installed between the pump and the city water supply to prevent any back flow from possibly contaminating the city water supply. Failure to do so could result in contamination of the water supply with consequential damages. Manufacturer assumes no responsibility for failure of user in not providing safeguards to city water systems.

- Step 1:** Locate appropriate city water supply and install anti-siphon check valve.
- Step 2:** Use appropriate pipe nipple to reduce piping to 1/8".
- Step 3:** Install appropriate needle valve and flow meter.
- Step 4:** Connect piping to one of three available seal flush ports on pump.
- Step 5:** Adjust needle valve to achieve desired flow to seal cavity (recommended 1 to 3 GPH).

INTERNAL FLUSH

Similar to above but internal supply (See Figure 9 for typical installation). Typically recommended for high viscosity applications ensuring lubrication to the mechanical seal.

In an internal flush system, the fluid is taken from the discharge and regulated from 1 to 3 GPH (Gallon Per Hour) to the seal cavity by means of a flow meter and needle valve.

- Step 1:** Select a T pipe coupling that is consistent with discharge pipe size and material. Couple to discharge piping.
- Step 2:** From this coupling, attach a needle valve with appropriate nipple reducing to 1/8" pipe or tube. Install appropriate flow meter.
- Step 3:** Connect 1/8" pipe or tube to one of three available seal cavity flush ports.
- Step 4:** Adjust needle valve to desired flow into seal cavity, (recommended 1 to 3 GPH).

CAUTION For alternate flush systems for hazardous fluid applications, hot liquid transfer, and those not addressed in this booklet, consult a qualified fluid handling specialist for assistance in specifying and installing flush systems according to local, state and federal environmental laws.

NOTE: Gears must be replaced as a set.

SHURflo Heavy-Duty Cast Iron and Bronze Rotary Close-Coupled External Gear Pumps

Operation (continued)

GEAR SPEED REDUCER OPTIONS

A gear reducer can be directly mounted between a standard pump and motor combination. Gear speed reducers are available for applications with high specific gravity, or when viscosities are greater than 500 SSU, using a standard 1725 RPM motor (See Appendix 2). The pump relationship between volume (GPM), pressure (PSI), speed (RPM), viscosity, specific gravity and horsepower is shown on performance chart in Shurflo Motor Manual form L-4082.

13. Unit is ready for operation.

Maintenance

⚠ WARNING

Make certain that the power source is

disconnected before attempting to service or disassemble any components!

If the power disconnect is out of sight, lock it in the open position and tag to prevent application of power.

CLEANING

Clean the suction line filter at regular intervals.

ELECTRIC MOTOR (IF SUPPLIED)

Properly selected and installed, electric motors are capable of operating for years with minimal maintenance. Periodically clean dirt accumulations from open-type motors, especially in and around vent openings, preferably by vacuuming (avoid imbedding dirt in windings). Oil and maintain as recommended by motor manufacturer.

GENERAL

Periodically check that electrical connections are tight. Pump should be drained if placed in an area that is subject to freezing temperatures.

PUMP REPAIR

DISASSEMBLY

(Refer to Figure 12 for Reference Numbers and Figures 10 & 11 for detailed seal and shaft assemblies.)

1. Pump Removal from Motor

a. Remove four bolts (Ref. No 25) from motor adapter (Ref. No 14) and gently pull pump assembly from motor.

b. Pump drive coupler does not need to be removed from motor unless motor needs to be replaced. (If so, refer to Assembly on Page 5.)

2. Gear and Shaft Assembly Removal

a. Remove cover plate (Ref. No. 1) (held by eight screws) and gasket (Ref. No. 3) if needed. Gently tap cover plate with rubber mallet to free it from dowel pins. Once cover is removed, the idler shaft and gear assembly can be pulled out of pump body (Ref. No. 4).

b. Remove the idler gear (Ref. No. 21) from the shaft (Ref. No. 23) by removing retaining rings (Ref. No. 22), then slide gears off the shaft end.

c. The drive gear (Ref. No 21) can be pulled out. Before drive shaft (Ref. No. 5) can be removed from body (Ref. No. 4), remove woodruff key (Ref. No. 24) by gently tapping key with drift pin. (Do not damage key or keyway upon removal.)

3. From the drive shaft end of the gear pump, remove the internal snap ring (Ref. No. 28) from the body (Ref. No. 4). The drive assembly, which consists of the drive shaft (Ref. No. 5), o-ring (Ref. No. 20), seal assembly (Ref. Nos. 7 & 8), seat retainer (Ref. No. 19), and retaining rings (Ref. No. 6), can now be

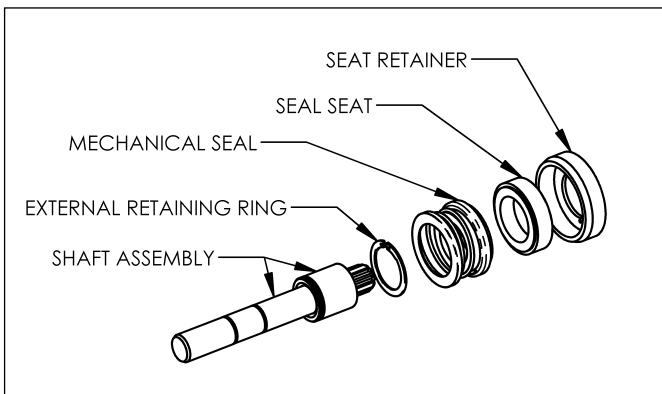

Figure 10 - Shaft and Seal Assembly

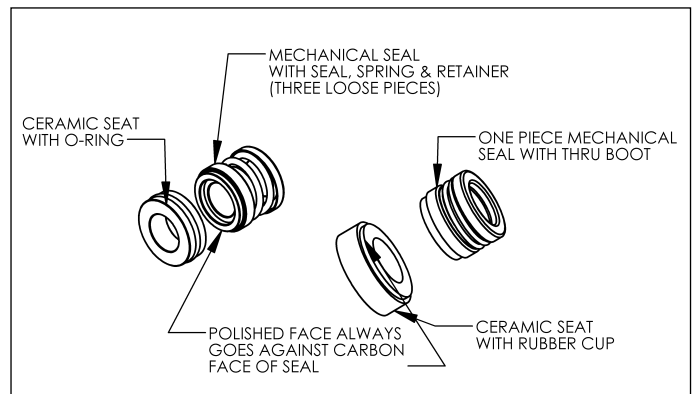

Figure 11 - Seal Types and Parts Identification

Bronze Models GMBN2VA, GMBN2VA3, GMBN2VA33, GMBN3VA, GMBN3VA4, GMBN3VA43, GMBN4VA, GMBN4VA5, GMBN4VA53, GMBN5VB, GMBN5VB6, GMBN5VB63, GMBN6VC, GMBN6VC7, GMBN6VC73

Cast Iron Models GMCV2VA, GMCV2VA3, GMCV2VA33, GMCV3VA, GMCV3VA4, GMCN3VA43, GMCV4VA, GMCV4VA5, GMCV4VA53, GMCN5VB, GMCV5VB6, GMCV5VB63, GMCV6VC, GMCV6VC7, GMCV6VC73

removed from the unit. Also remove the internal o-ring (Ref. No. 10) from the body.

REASSEMBLY

(Refer to Figure 12 for Reference Numbers and Figures 10 & 11 for detailed seal and shaft assemblies.)

1. Shaft/Seal Assembly

- a. Install inside o-ring (Ref. No. 10) into body (Ref. No. 4). Lubricate with water on bronze models and oil on cast iron models.
- b. Refer to assembling components on drive shaft (See Figure 10). When installing the seal on the shaft, wet with water and be cautious when sliding it into position. The spring retaining washer and spring are behind the seal with the carbon ceramic facing towards the keyed end of drive shaft.
- c. There are two possible types of seals. One style, the seal is one piece while the other style has a seal boot, spring and spring retainer. The seal seats can also be of two styles; one has a rubber boot and the other has an o-ring. Identify which type you have (See Figure 11). Press seal seat into the seal retainer (See Figures 10 & 11) using water as a lubricant. The white shiny ceramic face should be visible after pressing the seal to the seal retainer. It is recommended to use a cardboard washer or wood dowel when pushing the seal seat into the seal seat retainer. Any scratches, dirt, or fingerprints on the carbon ceramic faces will cause the seal to leak. The seal seat is stationary in the pump, while the seal on the shaft rotates, providing for the sealing surface.
- d. Slide the seal retainer onto the drive shaft holding seal onto the shaft.

e. Slide the drive shaft assembly (Ref. Nos. 5,6,7,8 &19) into the gear pump and secure with the internal retaining ring (Ref. No. 28). (Also see Figure 10.)

f. As a last step, install o-ring (Ref. No. 20) over the drive splines of the drive shaft (Ref. No. 5).

2. Gear and Shaft Installation

- a. Install external retainer ring (Ref. No. 22) onto drive shaft assembly (Ref. No. 5). Replace the woodruff key (Ref. No. 24) into the drive shaft (Ref. No. 5) using soft jaw pliers, or protect the shaft with rubber while pressing the key in place. Be sure that the key is level and that the key and shaft are free of burrs and scratches.
- b. The drive gear (Ref. No. 21) can be dropped in place and must be free to float on the shaft. Do not force the drive gear onto the shaft. Install external retainer ring (Ref. No. 22) onto drive shaft assembly (Ref. No. 5).
- c. The idler gear (Ref. No. 21) is placed on the idler shaft (Ref. No. 23) over the woodruff key and secured by the two external retaining rings (Ref. No. 22).
- d. Slide idler gear and shaft assembly into pump body (Ref. No. 4), rotating gear to get gears to mesh.
- e. Ensure that the gasket surfaces are clear of debris, and dry off surfaces.
Place new, clean and dry gasket on the pump body by sliding gasket over dowel pins. For bronze models, refer to Appendix 1, to identify the right thickness of gasket to use.

▲ CAUTION *Any foreign or liquid material on the gasket or the gasket surfaces will increase the space between the gears and the cover, and substantially reduce pump performance.*

- f. Slide cover over dowel pins. The drive shaft assembly will require slight compression as cover is tightened. Replace and tighten cover screws. Alternate from top to bottom and side to side while tightening screws. Torque cover screws (See Appendix 1).
- g. Reinstall pump to motor (See Assembly on page 5).
3. All pumps must be primed before start-up and the seal chamber needs to be filled (See Figure 5).

PRESSURE RELIEF VALVE

DISASSEMBLY AND REASSEMBLY

1. Loosen lock nut (Ref. No. 37) on regulator/relief valve adjustment screw (Ref. No. 36) and rotate clockwise (CW) 1-2 turns to free regulator/relief valve spring retainer (Ref. No. 34).
2. Unscrew and remove adjustment screw (Ref. No. 36) by rotating counterclockwise (CCW).
3. Unscrew valve end cap (Ref. No. 35) by rotating counterclockwise (CCW).
4. Remove valve spring (Ref. No. 31) and valve piston (Ref. No. 30), cover and/or valve end cap.
5. Unscrew pipe plug (Ref. No. 36) by rotating counterclockwise (CCW).

Inspection of relief valve components should include piston for wear and erosion, the spring and the o-rings for degradation. Components should be cleaned of accumulated build-up of solid matter. The pressure relief valve cover (Ref. No. 1) needs to be inspected for wear on the piston pressure relief valve seat (Ref. No. 29), the cover face and the bushing pockets. Replace any parts if worn.

To reassemble, reverse the disassembly steps above.

6. All pumps must be primed before start-up and the seal chamber needs to be filled (See Figure 5).

To order parts, contact a SHURflo Distributor or Order Direct.
Distributors can be found at www.shurfloindustrial.com.

Please provide following information:

- Model number
- Serial number (if any)
- Part description and number as shown in parts list

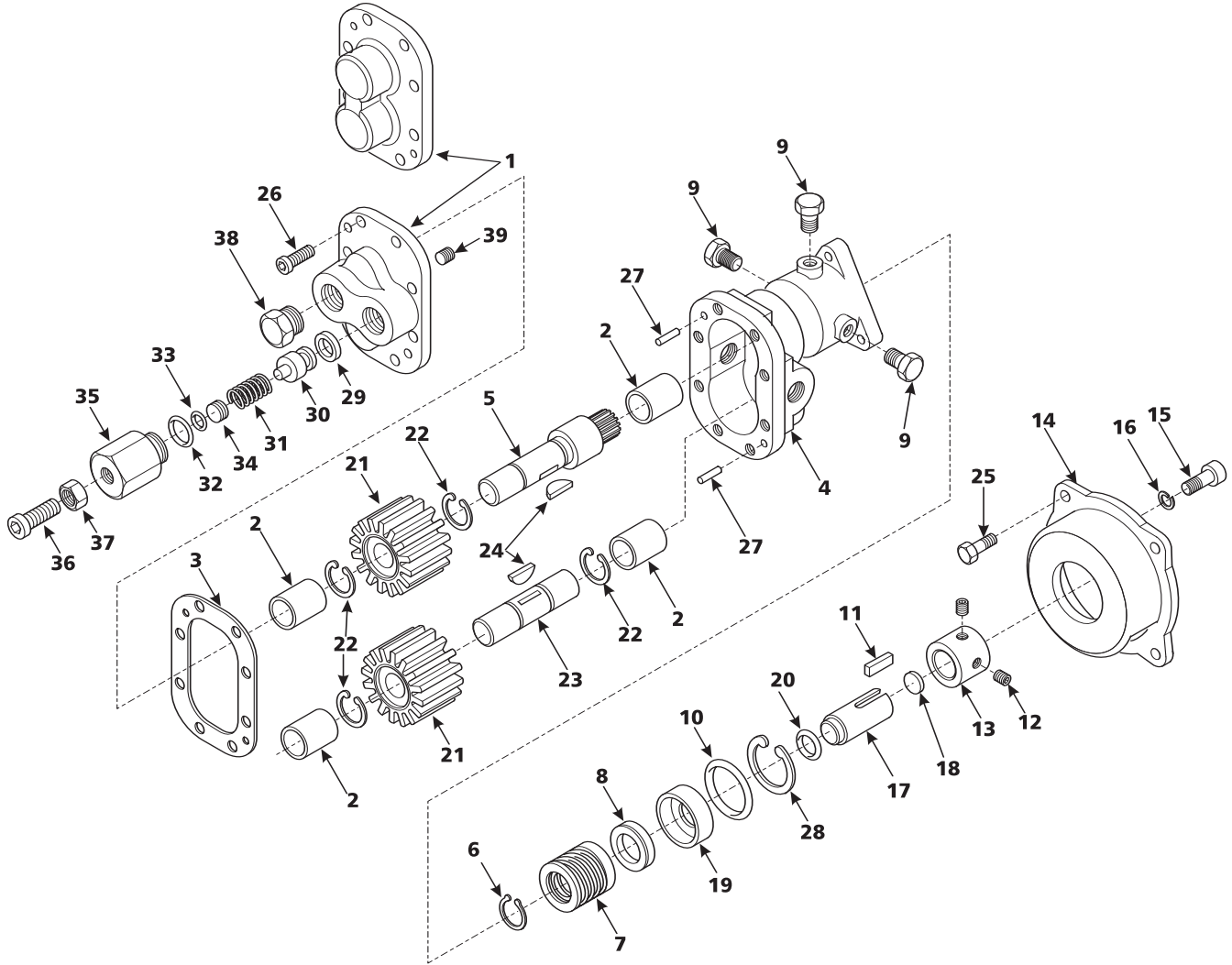

Figure 12 – Repair Parts Illustration

Repair Parts List for Bronze Model Pump Heads

Ref. No.	Description	Included In Kit	GMBN2VA* GMBN2VA3 GMBN2VA33	GMBN3VA* GMBN3VA4 GMBN3VA43	GMBN4VA* GMBN4VA5 GMBN4VA53	GMBN5VB* GMBN5VB6 GMBN5VB63	GMBN6VC* GMBN6VC7 GMBN6VC73	Qty.
1	Relief Valve Cover - Bronze (Std.)		21289	21290	21290	21291	21291	1
Optional	Plain Cover - (with Bushings - Ref. 2)		212335	212485	212485	212575	212575	
2	Bushing - Carbon Graphite		21332	21333	21333	21314	21314	4
3	Gasket (Vellumoid) Std.	1	21642	21643	21643	22906	22906	1
Optional	†High Temperature Gasket Kit		23952	23954	23954	23969	23969	
4	Body - Bronze		24571B	21300	21295	21299	21229	1
5	Drive Shaft Assembly (Buna) Std.	2	Kit	Kit	Kit	Kit	Kit	1
Optional	Drive Shaft Assembly (Viton)	3	Kit	Kit	Kit	Kit	Kit	
6	Ext. Ret. Ring - Steel	2, 3	Kit	Kit	Kit	Kit	Kit	1
7&8	Mech. Seal/Seat Assy. (Buna) Std.	2	246045	246075	246075	246075	246075	1
Optional	Mech. Seal/Seat Assy. (Viton)	3	246085	246115	246115	246115	246115	
9	Pipe Plug - Brass		00336	00336	00336	00336	00336	3
10	O-Ring (Buna) Std.	2	Kit	Kit	Kit	Kit	Kit	1
Optional	O-Ring (Viton)	3	Kit	Kit	Kit	Kit	Kit	
11	Sq. Key - Steel	2, 3, 6	Kit	Kit	Kit	Kit	Kit	1
12	Set Screw - Steel	6	Kit	Kit	Kit	Kit	Kit	2
13	Shaft Collar - Steel	6	Kit	Kit	Kit	Kit	Kit	1
14	Adapter - Cast Iron		21950	21950	21950	21956	21970	1
15	Soc.Head. Screw - Steel		21405	21405	21405	21405	21405	3
16	Lock Washer - Steel		15944	15944	15944	15944	15944	3
17	Spline Drive - Steel	2, 3, 6	Kit	Kit	Kit	Kit	Kit	1
18	Rubber Plug	2, 3, 6	Kit	Kit	Kit	Kit	Kit	1
19	Retainer - SS		24574	21383	21383	21383	21383	1
20	O-Ring - Buna-N (not a wetted part)	2, 3	Kit	Kit	Kit	Kit	Kit	1
21	Gear - Ryton (PPS)	1	13879	21137	12764	21136	13883	2
Optional	Gear - Steel		21456	21457	21458	21459	21460	
22	Ext. Ret. Ring - SS	1	21094	12840	12840	21063	21063	4
23	Idler Shaft - SS		21305	21307	21313	21337	21339	1
24	Woodruff Key - SS	1	21301	04432	12841	12841	12841	2
25	Capscrew - SS		11633	11633	11633	11633	22503	4
26	Soc. Head Screw - SS		21916	21916	21916	22049	22049	8
27	Dowel Pins - SS		22350	22350	22350	22350	22350	2
28	Int. Ret. Ring - Steel		04303	22246	22246	22246	22246	1
29	Relief Valve Seat - SS		22197	22197	22197	22198	22198	1
30	Piston - 303 SS	4, 5	Kit	Kit	Kit	Kit	Kit	1
31	Spring - 17-7 SS	4, 5	Kit	Kit	Kit	Kit	Kit	1
32	O-Ring (Buna) Std.	4	Kit	Kit	Kit	Kit	Kit	1
Optional	O-Ring (Viton)	5	Kit	Kit	Kit	Kit	Kit	
33	O-Ring (Buna) Std.	4	Kit	Kit	Kit	Kit	Kit	1
Optional	O-Ring (Viton)	5	Kit	Kit	Kit	Kit	Kit	
34	Retainer		21558	21558	21558	21563	21563	1
35	Cap		21555	21555	21555	21562	21562	1
36	Relief Valve Adjustment Screw - 18-8 SS		21710	21710	21710	21710	21710	1
37	Lock Nut - SS		21711	21711	21711	21711	21711	1
38	Internal Relief Plug - Brass		21705	21706	21706	21707	21707	1
39	External Relief Set Screw -SS (not factory installed)		21708	21709	21709	22349	22349	1
40	Motor (3/4 HP, 1 PH ODP) (For Pump Model GMBN2VA3)		217225	Optional	Optional	NA	NA	1
41	Motor (3/4 HP, 3 PH ODP) (For Pump Model GMBN2VA33)		246385	Optional	Optional	NA	NA	1
42	Motor (1 HP, 1 PH ODP) (For Pump Model GMBN3VA4)		Optional	221545	Optional	NA	NA	1
43	Motor (1 HP, 3 PH ODP) (For Pump Model GMBN3VA43)		Optional	246395	Optional	NA	NA	1
44	Motor (1-1/2 HP, 1 PH ODP) (For Pump Model GMBN4VA5)		Optional	Optional	221555	NA	NA	1
45	Motor (1-1/2 HP, 3 PH ODP) (For Pump Model GMBN4VA53)		Optional	Optional	246405	NA	NA	1
46	Motor (2 HP, 1 PH ODP) (For Pump Model GMBN5VB6)		NA	NA	NA	246415	NA	1
47	Motor (2 HP, 3 PH ODP) (For Pump Model GMBN5VB63)		NA	NA	NA	246425	NA	1
48	Motor (3 HP, 1 PH ODP) (For Pump Model GMBN6VC7)		NA	NA	NA	NA	246445	1
49	Motor (3 HP, 3 PH ODP) (For Pump Model GMBN6VC73)		NA	NA	NA	NA	246455	1
3,21,22,24	Kit 1 - Gear Repair Kit		22267	22268	22269	22270	22271	
5,6,7,9,10,11,17,18,20	Kit 2 - Dr. Shaft/Seal Kit (Buna)		24698	22334	22335	22336	22337	
5,6,7,9,10,11,17,18,20	Kit 3 - Dr. Shaft/Seal Kit (Viton)		24699	24700	24701	24702	24703	
30,31,32,33	Kit 4 - Relief Valve Kit (Buna)		22281	22281	22281	22282	22282	
30,31,32,33	Kit 5 - Relief Valve Kit (Viton)		24704	24704	24704	24707	24707	
11,12,13,17,18	Kit 6 - Spline Coupler Kit		24762	24763	24763	24764	24765	

(*) Pump head only (no motor).

NOTES: Motor-mounted models are indicated for the motor under the motor HP.

(†) For operating temperatures greater than 120° F. or high viscosities, gasket thickness must be adjusted.

Mech. seal and seat sold as set only (Ref. Nos. 7 & 8) - carbon ceramic faces with 18-8 SS components.

Remember when converting to a different seal/seat material to order the o-rings (Ref. No. 10, 32 & 33) of the same material.

SS = Stainless Steel Ryton = PPS (Polyphenylene Sulfide)

Kits do not ship with gaskets.

Repair Parts List for Cast Iron Model Pump Heads

Ref. No.	Description	Included In Kit	GMCV2VA*	GMCV3VA*	GMCV4VA*	GMCV5VB*	GMCV6VC*	Qty.
			GMCV2VA3	GMCV3VA43	GMCV4VA5	GMCV5VB6	GMCV6VC7	
1	Relief Valve Cover - Cast Iron (Std.)		21292	21293	21293	21294	21294	1
Optional	Plain Cover (without relief valve)		21234	21249	21249	21258	21258	
2	Bushing**		NR	NR	NR	NR	NR	
3	Gasket (Vellumoid) Std.	1	21642	21643	21643	22906	22906	1
4	Body (Cast Iron) Std.		24571C	21501	21299	21229	21300	1
5	Drive Shaft Assembly (Viton) Std.	5	Kit	Kit	Kit	Kit	Kit	1
Optional	Drive Shaft Assembly (Buna)	4	Kit	Kit	Kit	Kit	Kit	1
6	Ext. Ret. Ring	4, 5	Kit	Kit	Kit	Kit	Kit	1
7&8	Mech. Seal/Seat Assy. (Viton) Std.	5	24608S	24611S	24611S	24611S	24611S	1
Optional	Mech. Seal/Seat Assy. (Buna)	4	24604S	24607S	24607S	24607S	24607S	
9	Pipe Plug		12313	12313	12313	12313	12313	3
10	O-Ring (Viton) Std.	5	Kit	Kit	Kit	Kit	Kit	1
Optional	O-Ring (Buna)	4	Kit	Kit	Kit	Kit	Kit	
11	Sq. Key Steel	4, 5, 6	Kit	Kit	Kit	Kit	Kit	1
12	Set Screw - Steel	6	Kit	Kit	Kit	Kit	Kit	2
13	Shaft collar - Steel	6	Kit	Kit	Kit	Kit	Kit	1
14	Adapter - Cast Iron		21950	21950	21950	21956	21970	1
15	Soc.Head. Screw - Steel		21405	21405	21405	21405	21405	3
16	Lock Washer - Steel		15944	15944	15944	15944	15944	3
17	Spline Drive - Steel	4, 5, 6	Kit	Kit	Kit	Kit	Kit	1
18	Rubber Plug	4, 5, 6	Kit	Kit	Kit	Kit	Kit	1
19	Retainer - SS		24574	21616	21616	21616	21616	1
20	O-Ring - Buna-N (not a wetted part)	4, 5	Kit	Kit	Kit	Kit	Kit	
21	Gear - Steel	1	21456	21457	21458	21459	21460	2
Optional	Gear - Ryton (PPS)		13879	21137	12764	21136	13883	
22	Ext. Ret. Ring - Steel	1	04304	12840	12840	12840	21063	4
23	Idler Shaft - Steel		21447	21449	21451	21453	21455	1
24	Woodruff Key	1	21301	11515	12622	12622	12622	2
25	Capscrew		11633	11633	11633	11633	22503	4
26	Soc. Head Screw - SS		21916	21916	21916	22049	22049	8
27	Dowel Pins - SS		22350	22350	22350	22350	22350	2
28	Int. Ret. Ring - Steel		04303	22246	22246	22246	22246	1
29	Relief Valve Seat - SS**		NR	NR	NR	NR	NR	1
30	Piston - 303 SS	2, 3	Kit	Kit	Kit	Kit	Kit	1
31	Spring - 17-7 SS	2, 3	Kit	Kit	Kit	Kit	Kit	1
32	O-Ring (Viton Standard)	2	Kit	Kit	Kit	Kit	Kit	1
	O-Ring (Buna Optional)	3	Kit	Kit	Kit	Kit	Kit	
33	O-Ring (Viton Standard)	2	Kit	Kit	Kit	Kit	Kit	1
	O-Ring (Buna Optional)	3	Kit	Kit	Kit	Kit	Kit	
34	Retainer - SS		21422	21422	21422	21435	21435	1
35	Cap		21421	21421	21421	21434	21434	1
36	Relief Valve Adjustment Screw - 18-8 SS		21710	21710	21710	21710	21710	1
37	Lock Nut - SS		21711	21711	21711	21711	21711	1
38	Internal Relief Plug - Steel		21409	21419	21419	21433	21433	1
39	External Relief Set Screw - SS (not factory installed)		21708	21709	21709	22349	22349	1
40	Motor (3/4 HP, 1 PH ODP) (For Pump Model GMCV2VA3)		21722S	Optional	Optional	NA	NA	1
41	Motor (3/4 HP, 3 PH ODP) (For Pump Model GMCV2VA33)		24638S	Optional	Optional	NA	NA	1
42	Motor (1 HP, 1 PH ODP) (For Pump Model GMCV3VA4)		Optional	22154S	Optional	NA	NA	1
43	Motor (1 HP, 3 PH ODP) (For Pump Model GMCV3VA43)		Optional	24639S	Optional	NA	NA	1
44	Motor (1-1/2 HP, 1 PH ODP) (For Pump Model GMCV4VA5)		Optional	Optional	22155S	NA	NA	1
45	Motor (1-1/2 HP, 3 PH ODP) (For Pump Model GMCV4VA53)		Optional	Optional	24640S	NA	NA	1
46	Motor (2 HP, 1 PH ODP) (For Pump Model GMCV5VB6)		NA	NA	NA	24641S	NA	1
47	Motor (2 HP, 3 PH ODP) (For Pump Model GMCV5VB63)		NA	NA	NA	24642S	NA	1
48	Motor (3 HP, 1 PH ODP) (For Pump Model GMCV6VC7)		NA	NA	NA	NA	24644S	1
49	Motor (3 HP, 3 PH ODP) (For Pump Model GMCV6VC73)		NA	NA	NA	NA	24645S	1
3,21,22,24	Kit 1 - Gear Repair Kit		22272	22273	22274	22275	22277	
30,31,32,33	Kit 2 - Relief Valve Kit (Viton)		24709	24709	24709	24712	24712	
30,31,32,33	Kit 3 - Relief Valve Kit (Buna)		22295	22295	22295	22296	22296	
5,6,7,9,10,11,17,18,20	Kit 4 - Dr. Shaft/Seal Kit (Buna)		24726	22338	22339	22340	22341	
5,6,7,9,10,11,17,18,20	Kit 5 - Dr. Shaft/Seal Kit (Viton)		24735	24731	24732	24733	24734	
11,12,13,17, 18	Kit 6 - Spline Coupler Kit		24762	24763	24763	24764	24765	

(*) Pump head only (no motor).

(**) Cast Iron pump bushings and pressure relief valve seat are machined into pump housing and cannot be replaced.

NOTE: Cast Iron pumps are not to be used for pumping water-based fluids; fluids pumped must have lubrication.

Motor-mounted models are indicated for the motor under the motor HP.

It is recommended that when bushing wear/shaft wear is excessive on cast iron models, the pump head be replaced.

Mech. seal and seat sold as set only (Ref. Nos. 7&8) - carbon ceramic faces with 18-8 SS components.

Remember when converting to a different seal/seat material to order the o-rings (Ref. Nos. 10, 32 & 33) of the same material.

SS = Stainless Steel Ryton = PPS (Polyphenylene Sulfide) NR = Not Required.

Kits do not ship with gaskets.

Optional Close-Coupled Gear Speed Reducers are available (See Appendix 2).

Bronze Models GMBN2VA, GMBN2VA3, GMBN2VA33, GMBN3VA, GMBN3VA4, GMBN3VA43, GMBN4VA, GMBN4VA5, GMBN4VA53, GMBN5VB, GMBN5VB6, GMBN5VB63, GMBN6VC, GMBN6VC7, GMBN6VC73

Cast Iron Models GMCV2VA, GMCV2VA3, GMCV2VA33, GMCV3VA, GMCV3VA4, GMCN3VA43, GMCV4VA, GMCV4VA5, GMCV4VA53, GMCN5VB, GMCV5VB6, GMCV5VB63, GMCV6VC, GMCV6VC7, GMCV6VC73

Appendix 1 - Gear Pump Gasket Adjustment for Temperature (Bronze Models only)

Gear pump is factory assembled to operate within a temperature range of 70° – 120° F (20° – 50° C). For temperatures outside this range, please see the table below for your series and port size pump.

NOTE: Always refer to the original owner’s manual repair and maintenance sections on pump disassembly and assembly for more detailed instructions.

NOTE: When pumping fluids of high viscosity (>500 SSU), the required torque and HP can be reduced by adding a gasket for increased gear clearance.

Gasket Installation Instructions (refer to assembly diagram below):

1. Turn off power to pump, turn off inlet and outlet valves, and relieve pressure in lines.
2. Allow pump to cool.

3. Remove cover screws (1), cover (2) and gasket (3). Be sure to mark proper orientation of cover and pump body.
4. Replace gaskets (3) per instructions listed in table.
5. Replace cover (2) and cover screws (1) according to orientation marked in step 3.
6. Tighten cover screws (1) in sequence listed on diagram. Use torque specifications listed in table.

Kit PN	NPT Port Size	Temp Range	Instructions	Bolt Torque	
Bronze Gear Pump Series	23952	Pumps with 3/8" ports	Up to 120° F (50° C)	Use standard vellumoid/paper gasket as shipped (0.006" thick)*	23 in.-lbs. (2.6 N-m)
			120° F – 210° F (50° C – 99° C)	Use optional thicker (0.015") vellumoid/paper gasket	
	23954	Pumps with 1/2" and 3/4" ports	Up to 120° F (50° C)	Use standard vellumoid/paper gasket as shipped (0.006" thick)*	23 in.-lbs. (2.6 N-m)
				120° F – 210° F (50° C – 99° C)	
	23969	Pumps with 1" and 1-1/4" ports	Up to 70° F (20° C)	Use optional thinner (0.006") vellumoid/paper gasket	75 in.-lbs. (8.5 N-m)
			70° F – 120° F (20° C – 50° C)	Use standard vellumoid/paper gasket as shipped (0.010" thick)*	
120° F – 210° F (50° C – 99° C)			Use 2X optional thinner (for a total of 0.012") vellumoid/paper gasket		

***Standard Set-up**

Gear Pump Gasket Install Assembly

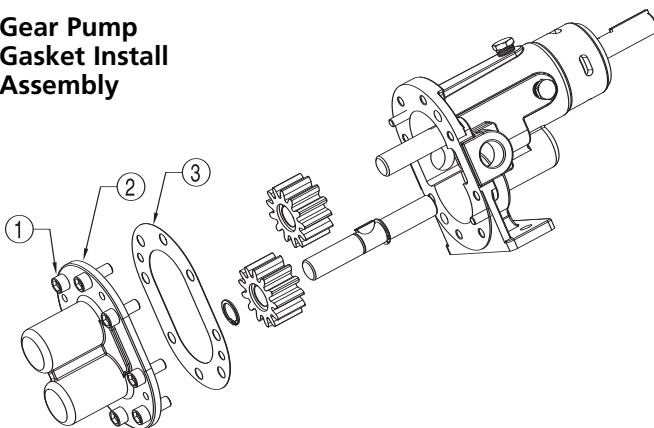

Bolt Tightening Sequence

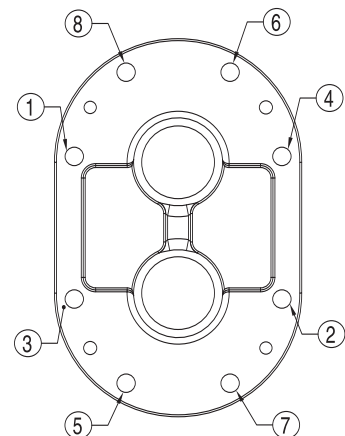

SHURflo Heavy-Duty Cast Iron and Bronze Rotary Close-Coupled External Gear Pumps

Appendix 2 - Optional C-Flanged Pump Speed Gear Reducers

GEAR SPEED REDUCER OPTIONS

A gear reducer can be directly mounted between a standard pump and motor combination. Gear speed reducers are available for applications with high

specific gravity, or when viscosities are greater than 500 SSU, using a standard 1725 RPM motor. The pump relationship between volume (GPM), pressure (PSI), speed (RPM), viscosity, specific

gravity and horsepower is shown on performance chart in Shurflo Motor Manual form L-4082.

Model Number	Description	L*	M*	RPM Out**	Ship Weight (lbs.)
AGR56C600	Gear Reducer, 56C to 56C, 3.0 ratio	5.177	1.675	583	21
AGR56C900	Gear Reducer, 56C to 56C, 2.0 ratio	5.177	1.675	875	21
AGR56C1200	Gear Reducer, 56C to 56C, 1.5 ratio	5.177	1.675	1167	21
AGR145TC600	Gear Reducer, 145TC to 145TC, 3.0 ratio	5.625	2.875	583	29
AGR145TC900	Gear Reducer, 145TC to 145TC, 2.0 ratio	5.625	2.875	875	29
AGR145TC1200	Gear Reducer, 145TC to 145TC, 1.5 ratio	5.625	2.875	1167	29
AGR184TC600	Gear Reducer, 184TC to 184TC, 3.0 ratio	7.43	2.875	583	56
AGR184TC900	Gear Reducer, 184TC to 184TC, 2.0 ratio	7.43	2.875	875	56
AGR184TC1200	Gear Reducer, 184TC to 184TC, 1.5 ratio	7.43	2.875	1167	56

(*) L dimension (in inches) is length of the gear reducer. M dimension (in inches) is the offset of the reducer output centerline from the motor centerline. All reducers may be rotated in 90° increments, changing the orientation of the offset from top to side to bottom.

(**) Based on 1750 RPM motor speed.

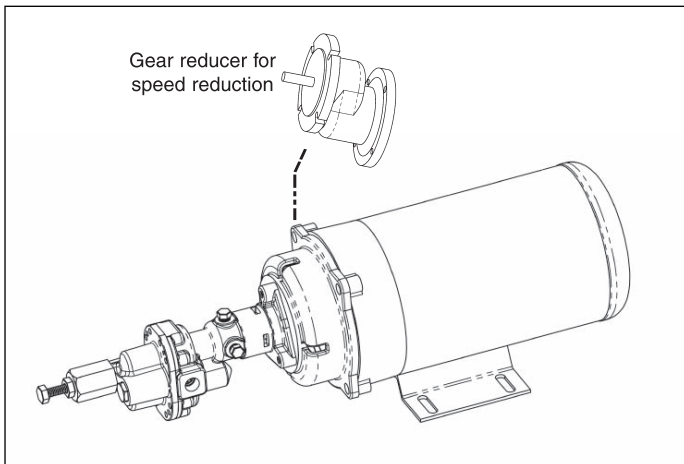

Disassemble Pump From Motor and Insert Gear Reducer

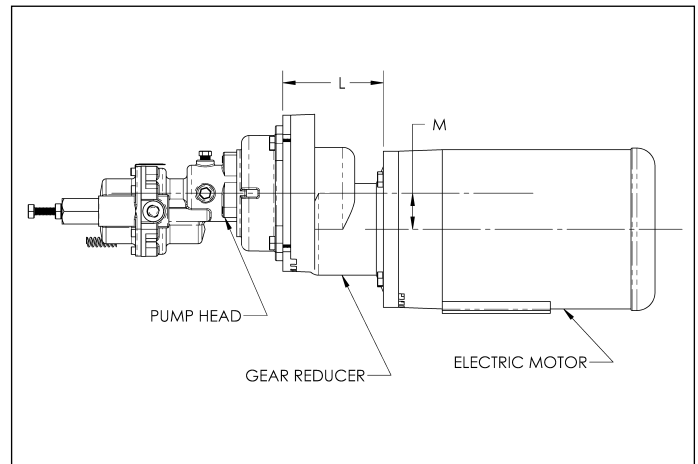

Gear Reducer Installed between Pump and Motor (References L and M are dimensions in chart above.)

