

Please read and save this Repair Parts Manual. Read this manual and the General Operating Instructions carefully before attempting to assemble, install, operate or maintain the product described. Protect yourself and others by observing all safety information. The Safety Instructions are contained in the General Operating Instructions. Failure to comply with the safety instructions accompanying this product could result in personal injury and/or property damage! Retain instructions for future reference. AMT reserves the right to discontinue any model or change specifications at any time without incurring any obligation.

©2015 AMT Pump Company, A Subsidiary of The Gorman-Rupp Company, All Rights Reserved.

Periodic maintenance and inspection is required on all pumps to ensure proper operation. Unit must be clear of debris and sediment. Inspect for leaks and loose bolts. Failure to do so voids warranty.

# Self-Priming Centrifugal Pedestal Pumps

Refer to pump manual 1808-635-00 for General Operating and Safety Instructions.

## DESCRIPTION

This self-priming (to 20 ft. lift) centrifugal pump is used for direct coupling or pulley drive medium head applications. Specific applications include liquid transfer, irrigations, dewatering, etc. Clog-resistant impeller can handle sediment laden liquids and semi-solids up to 3/8" diameter. Handles liquids from 40° to 180° F (4° to 82° C). For use with nonflammable, non-abrasive liquids compatible with pump component materials.

## SPECIFICATIONS

Suction Inlet	1¼" NPT
Discharge Outlet	1¼" NPT
Shaft Diameter	5/8"
Keyway	3/16 x 3/32"
Dimensions (overall)	7 ¾" H x 6 ⅝" W x 11" L
Weight (approximate)	23 lbs.
Basic Construction	Cast Iron
Mechanical Seal	Buna-N w/ Carbon Ceramic Faces
Max. Suction Lift	14 ft. @ 1750, 2300 and 2800 RPM 20 ft. @ 3450 RPM

## Performance and Pulley Drive Chart

Drive	PERFORMANCE								PULLEY DRIVE		
	Recommended	10'	15'	20'	30'	40'	50'	60'	*Max. Head	Motor Pulley Size "A" Section V-Belt	Pump Pulley Size "A" Section V-Belt
1/4HP @ 1750 RPM	1,240	120	-	-	-	-	-	-	16 ft.	2 ½" for 3500 RPM Motor 3" for 1750 RPM Motor	5" for 3500 RPM Motor 3" for 1750 RPM Motor
1/3 HP @ 2300 RPM	2,245	1,740	1,040	-	-	-	-	-	28 ft.	3" for 3500 RPM Motor 4" for 1750 RPM Motor	4 ½" for 3500 RPM Motor 3" for 1750 RPM Motor
1/2 HP @ 2800 RPM	3,040	2,740	2,325	1,220	-	-	-	-	34 ft.	2 ½" for 3500 RPM Motor 4" for 1750 RPM Motor	3" for 3500 RPM Motor 2 ½" for 1750 RPM Motor
1 HP @ 3450 RPM	3,950	3,780	3,560	2,970	2,170	1,160	-	-	55 ft.	3" for 3500 RPM Motor 6" for 1750 RPM Motor	3" for 3500 RPM Motor 3" for 1750 RPM Motor

(\*) Shut-off; to convert to psi, divide by 2.31.

# Self-Priming Centrifugal Pedestal Pumps

## MAINTENANCE

### **▲ WARNING**

**Make certain that unit is disconnected from power source before attempting to service or remove any components!**

## MECHANICAL SEAL REPLACEMENT

Refer to Figure 1.

**IMPORTANT:** Always replace both the seal seat and the seal head to ensure proper mating of components! Handle the mechanical seal replacement carefully as the precision lapped faces can be damaged easily.

1. Disassemble the bearing housing (Ref. No. 5) and gasket (Ref. No. 6) from the pump casing (Ref. No. 11) by removing the 4 hex head cap screws (Ref. No. 13).
2. Unscrew the impeller, (right hand thread, Ref. No. 10).
3. Carefully pry up on the seal cartridge (Ref. No. 8) using two large screwdrivers. Often, this portion of the seal can be removed by pulling off with your fingers.
4. Remove the shaft bearing assembly (Ref. No. 3) by first removing the snap ring (Ref. No. 1) and shims. Push the shaft bearing assembly out of the bearing housing by tapping on the threaded end of the shaft with a rawhide mallet or block of wood and hammer. As shaft is being pulled from the housing, the shaft slinger (Ref. No. 4) between the seal and the bearing will fall free.
5. Pry the seal seat (Ref. No. 7) from the cavity in the bearing housing.
6. Replace shaft bearing assembly by sliding the assembly into the housing, threaded shaft first. As shaft end emerges from bearing cavity before it enters into seal cavity, slip the rubber slinger washer (Ref. No. 4) up from the underside, over the end of the shaft. Some manipulation through the seal cavity opening may be required. Push shaft bearing assembly home by gently tapping on keyway end of shaft with a rawhide mallet. Replace snap ring and shims.
7. Carefully wipe the surface of the ceramic seat with a clean cloth.
8. Wet the rubber portion of the ceramic seat with a light coating of soapy water.
9. Press the seal seat squarely into the cavity in the bearing housing. If the seal seat does not press squarely into the cavity, it can be adjusted in place by pushing on it with a piece of pipe.

**NOTE:** Always use a piece of cardboard between the pipe and the seal seat to avoid scratching the seal seat. This is a lapped surface and must be handled very carefully.

10. After the seal is in place, be sure that the face is clean and has not been scratched or cracked.
11. Using a clean cloth, wipe the shaft and make sure that it is perfectly clean.
12. Apply a light coating of soapy water on the inside of the rubber drive ring inside the seal cartridge assembly. Slide the seal assembly onto the shaft (with the sealing face first), sliding the rubber drive ring just up over the shaft shoulder. Do not touch or wipe the seal head.
13. Replace any shim washers (Ref. No. 9) you may have removed in disassembly.
14. Screw the impeller back in place, tightening until it is against the shoulder provided on the shaft.
15. Replace pump casing on the bearing housing, using a new gasket to prevent leakage. Turn shaft by hand to ensure free rotation. If striking of the impeller on the pump casing is noted, disassemble and remove shim washers as required.

## BEARING HOUSING SERVICE

1. Remove front pump assembly as described under "Mechanical Seal Replacement"
2. Remove shaft/bearing assembly (Ref. No. 3) by first removing retaining ring (Ref. No. 1). Push shaft/bearing assembly out of pedestal (Ref. No. 5) by rapping on threaded end of shaft with a rawhide mallet, or block of wood and a hammer.
3. Replace shaft/bearing assembly by sliding assembly into housing threaded end first. Push shaft bearing assembly completely in by gently tapping on keyway end of shaft with a rawhide mallet. Replace retaining ring.
4. Reassemble pump as described in "Mechanical Seal Replacement".

## SHIM ADJUSTMENT

1. When installing a replacement, impeller (Ref. No. 5) or casing (Ref. No. 11) it may be necessary to vary the number of impeller shims (Ref. No. 9) that will be required. This is easily done by adding one shim more than was removed and reassembling pump as described in MECHANICAL SEAL REPLACEMENT section.

**NOTE:** When adding or removing shims, it is best to proceed with a 0.010" increment each time. While tightening unit together, turn shaft and feel for shaft seizing. If shaft begins to seize before fasteners are completely tight, disassemble pump and remove one shim and repeat assembly.

2. Once having added one shim more than original, ensure that casing and pedestal are firmly fitted (check fasteners Ref. No. 13). When pump shaft turns freely add shims until it does strike, then remove a 0.010" shim. This should allow proper clearance.
3. Proper running clearance for impeller should be as close as possible to volute without striking; maximum clearance is 1/32" (0.032").
4. Follow above procedure until proper clearance is obtained. This will ensure maximum performance.

## For Repair Parts contact dealer where pump was purchased.

Please provide following information:

-Model Number

-Serial Number (if any)

Part description and number as shown in parts list

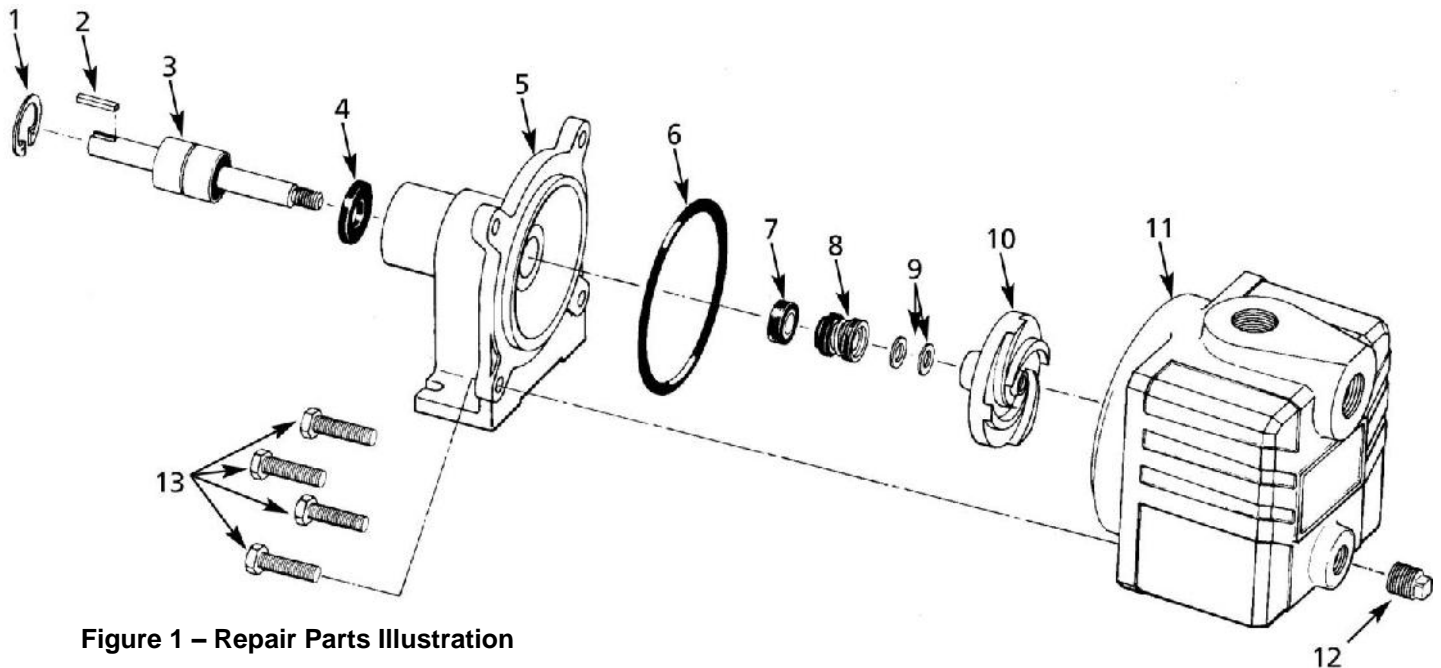

Figure 1 – Repair Parts Illustration

## Repair Parts List

Ref. No.	Description	Part No.	Qty.
1	Snap Ring	1516-000-00	1
2	3/16" Square Shaft Key	1517-000-00	1
3	+ Shaft & Bearing Assembly	1509-140-90	1
4	Slinger Washer (not required)	1534-000-00	1
5	Bearing Housing/Adapter	1562-000-01	1
6	Gasket, Buna-N	1531-000-00	1
	Gasket, Viton (optional)	1532-000-00	1
7,8	◇ Seal Assembly, Buna-N	1640-161-90	1
	◇ Seal Assembly, Viton (optional)	1640-161-91	1
9	Impeller Shim Kit	1657-000-90	-
10	Impeller	2850-010-03	1
11	Casing	1558-000-02	1
12	1/2" NPT Drain Plug	*	1
13	3/8" - 16 x 2" Hex Head Cap Screw	*	4
△	Bearing Shim Kit	1696-003-90	-

(\*) Standard Hardware Item, Available Locally

(◇) Seal assembly available as set only (includes seal head and seat).

(+) Shaft and bearings not available separately.

(△) Not Shown



AMT Pump Company  
(herein "AMT")  
400 Spring Street  
Royersford, PA 19468  
Phone: (610) 948-3800  
Fax: (610) 948-5300  
www.amtpump.com

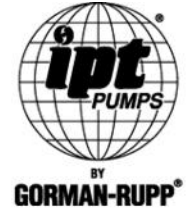

## General Information

**SALES POLICY:** AMT products are sold through our established Distributors. We do not sell direct to the consumer or organization not entitled to trade recognition. Therefore, possession of our catalogs and/or price list(s) does not infer an offer to sell.

**MINIMUM ORDER:** We appreciate your order, however, all orders are subject to a minimum \$35.00 net invoice charge (excluding freight). This applies to all pump and parts purchase orders.

**PRICES:** Prices are subject to change without notice. All orders accepted are subject to prices in effect at time of shipment.

**PAYMENT TERMS:** Terms, upon establishment of credit, are Net 30 days. Past due accounts may be subject to a service charge of 1.5% per month. Domestic or assignable letter of credit is required for all export trade.

**PAST DUE ACCOUNTS:** AMT reserves the right to withhold open account shipments on any past due account. Invoices are considered past due after thirty (30) days. In the interest of sound business, all orders are subject to approval of the Credit Department.

**SHIPPING INSTRUCTIONS:** All shipments will be made F.O.B. the factory. Where instructions for shipment do not appear on the order, the shipment will be made according to our best judgment. Full risk of loss (including transportation delays and losses) shall pass to the customer upon delivery of the products to the carrier at the F.O.B. point. When loss or delay occurs, primary responsibility for tracing rests with the customer. When there is LOSS or APPARENT VISIBLE DAMAGE to a shipment, when tendered for delivery, *DO NOT* give the carrier a clear receipt. Note such damage on the carrier's delivery receipt and *HAVE THE DRIVER SIGN THE RECEIPT.*

**PRODUCT REVISIONS:** AMT reserves the right to discontinue, change or improve its products or any portions thereof without being obligated to provide such a change or improvement for units sold and/or shipped prior to such a change or improvement.

## 12 Month Limited Warranty

### EXTENT AND DURATION OF LIMITED WARRANTY

**Coverage:** AMT Pump Company (herein "AMT") or IPT Pumps by Gorman-Rupp (herein "IPT") or Gorman-Rupp Industries Division of The Gorman-Rupp Company, Patterson, or the Gorman-Rupp Company (herein referred to as "G-R Unit") each individually warrants that its products and parts shall be free from defects in material and workmanship for twelve (12) months from the date of purchase by the original end user when installation is made and maintenance is performed in accordance with G-R Unit's recommendations. Wear and tear resulting from use and items normally consumed in use are not covered.

### EXCEPTIONS

( A ) This Limited Warranty shall not apply to mechanical seals in AMT or IPT pumps and the following products and parts: engines, motors, trade accessories and all other products, components, parts and materials not manufactured by the G-R Units. These items may, however, be covered by the warranties of their respective manufacturers. ( B ) This warranty does not extend to or apply to any unit which has been repaired or altered at any place other than by a G-R Unit, or by persons not expressly approved by a G-R Unit to make repairs or alterations, nor to any unit the serial number, model number or identification of which has been removed, defaced or altered. ( C ) This warranty does not extend to any product manufactured by a G-R Unit, which has been subjected to mis-use, neglect, accident, improper installation, or use in violation of instructions furnished by a G-R Unit. ( D ) Pump Kits: This warranty does not extend to any product sold by a G-R Unit unassembled as a Pump Kit. Pump Kits are warranted against defects in material and workmanship for 60 days from the date of shipment from a G-R Unit. Any Pump Kit parts deemed defective by a G-R Unit will be replaced free of charge within 60 days of shipment. Pump Kits are not returnable for credit.

### LIMITATIONS

**THE G-R UNITS' SOLE AND EXCLUSIVE WARRANTY WITH RESPECT TO THEIR PRODUCTS AND PARTS IS THIS LIMITED WARRANTY. THIS LIMITED WARRANTY IS IN LIEU OF ALL OTHER EXPRESS AND/OR IMPLIED WARRANTIES, INCLUDING IMPLIED WARRANTIES OF MERCHANTABILITY AND FITNESS FOR PARTICULAR PURPOSE.**

### EXCLUSIVE REMEDY AND DAMAGES

The sole and exclusive remedy for breach of this Warranty by a G-R Unit and the entire extent of its liability for such breach or for damages arising from the use of the products and parts covered under this Limited Warranty, shall be as follows:

**LEAD TIME:** Products designated "Quick Ship Product", also referred to as "QSP" will normally be shipped within 24 hours of receipt of a non-cancellable purchase order. Only limited quantities of "QSP" pumps are available.

**STANDARD LEAD TIME:** Lead time is two weeks for all non "QSP" product. AMT reserves the right to revise lead times as required due to availability of materials and all other causes beyond our control.

**VIP SHIPMENT:** Select AMT and IPT branded pumps are available for next day shipment for non-QSP (Quick Ship Products) items and subjected to a specific model surcharge per unit noted in the respective price book. Requires calling for availability, confirmation and a non-cancellable purchase order or credit card payment prior to shipment. The expedited shipping charges are an additional cost added separately from the VIP charges per item. AMT reserves the right to revise lead times as required due to availability of materials and all other causes beyond our control. QSP quantities are limited as determined by AMT.

ALL purchase orders must be submitted via hard copy sent to AMT customer service department by fax, EDI or e-mail.

**RETURN GOODS POLICY:** Goods shall not be returned without a return goods authorization number (RGA) issued by AMT customer service. The RGA number must be listed on the packing list. Only current model and part numbers with a valid date code may be returned (within one year from date of purchase). **A 20% restocking and packaging charge will apply to all returns. All shipping charges must be pre-paid. No exceptions.**

**ORDER CHANGES BY CUSTOMER:** Orders in process may not be changed except with written consent and may be subject to special charges.

- Repair or Replacement:** If inspection shows that any G-R Unit product or part covered under this Limited Warranty is defective in materials or workmanship, the G-R Unit shall repair or replace the defective or non-conforming product or part without charge, whichever the G-R Unit chooses. You must have properly maintained and used the product or part claimed to be defective in accordance with the maintenance schedule or manual, which comes with the product. No allowance will be made for labor, installation, removal, transportation or other charges incurred by you in connection with such repair or replacement.
- To obtain the above remedy:
  - Immediately notify the G-R Unit upon discovery of the claimed defect in materials or workmanship and provide the serial number or date code of the product and/or part(s) or provide the G-R Unit with the invoice or bill of sale referencing the product by no later than the expiration date of the warranty period.
  - The G-R Unit will advise whether inspection will be necessary and how whether repair or replacement will be made. If inspection by the G-R Unit is necessary, the pump or defective part must be sent freight pre-paid to the G-R Unit. Return shipment will be F.O.B. the G-R Unit's plant.
  - Return Goods Authorization Requirement:** No product will be accepted for return or replacement without the prior written authorization of the G-R Unit. Upon such authorization, and in accordance with instructions from the G-R Unit, the product will be returned to the G-R Unit, shipping charges prepaid by the Buyer.
- Damages:** The G-R Unit's liability for damages for breach of this Limited Warranty shall not exceed the amount of the purchase price of the product or part(s) in respect to which Such damages are claimed. **IN NO EVENT SHALL THE G-R UNITS BE LIABLE FOR INCIDENTAL, CONSEQUENTIAL OR SPECIAL DAMAGES FOR BREACH OF THIS LIMITED WARRANTY.**

Some states do not allow the exclusion or limitation of incidental or consequential damages, so the above limitation or exclusion may not apply to you. This Limited Warranty gives you specific legal rights, and you may also have other rights, which vary from state to state.