

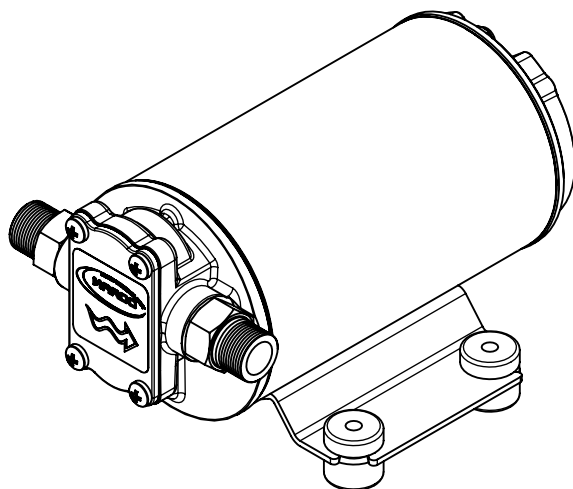

**SELF PRIMING ELECTRIC PUMP
FOR TRANSFERRING LUBRICATING OILS
OR VISCOUS FLUIDS**

INSTRUCTIONS FOR USE

**164 080 12-US - UP6/OIL 12V
164 080 13-US - UP6/OIL 24V**



CE

19/05/14 Rev.03

A

PRODUCT DESCRIPTION

Self-priming electric pump for the transfer of liquids of varied nature for discontinuous or intermittent usage.

The pumping elements are made up of bronze gear drives which can possibly even run dry for brief periods.

B

TECHNICAL DETAILS

CODE	TYPE	VOLT	FUSE	FLOW RATE	WEIGHT	P.CS x CART.
164 080 12-US	UP6/OIL	12	10 A	2,1 gpm	6,8 lb	6
164 080 13-US		24	7,5 A			

C

AMBIENT CONDITIONS

TEMPERATURE: min.-10°C 14°F-max.60°C 140°F **RELATIVE HUMIDITY:** max. 90 %



WARNING: the above indicated temperature ranges are applicable to all components of the pump and these limits must be respected in order to avoid any possible damage or malfunctioning.

D

OPERATING CYCLE

The pump has been designed for discontinuous use. Under conditions of high operating pressures (eg. with closed or blocked outlet, excessive length of the delivery circuit and/or excessive pressure due to accessories), it can be subjected to elevated stresses and overheating and therefore should not be used for prolonged periods under such conditions.

E

APPLICATIONS

There are numerous fields of applications for the pump, however only exclusively with the allowed liquids mentioned:

- transfer of lubricating oil
- transfer of viscous liquids
- transfer of oils, antifreezing
- circulation of viscous liquids
- draining of engine sumps

FLUIDS ALLOWED / NOT ALLOWED

F

ALLOWED:

FRESH WATER (max 85°C-185°F)

ENGINE OIL, max viscosity 350 cSt, max 248 °F

DIESEL FUEL Minimum flashpoint (PM): 38°C-100°F.

NOT ALLOWED:

- PETROL (GASOLINE)
- FLAMMABLE LIQUIDS with PM < 100 °F
- LIQUIDS WITH VISCOSITY > 350 cSt
- FOODSTUFF LIQUIDS
- CORROSIVE CHEMICAL PRODUCTS

- SOLVENTS

RELATED DANGERS

- FIRE EXPLOSION
- FIRE EXPLOSION
- MOTOR OVERHEATING
- FOODSTUFF LIQUID CONTAMINATION
- PUMP CORROSION
- INJURY TO PERSONNEL
- FIRE EXPLOSION
- DAMAGE TO SEALS

WARRANTY EXPIRES IF MAX FLUID TEMPERATURE IS EXCEEDED

TRANSPORTATION AND HANDLING

G

Due to limited weight and dimensions the pump does not require the use of any special handling or lifting equipment. When handling manually, normal personal protective gear should be worn (safety shoes with toe piece, etc.)

The pump is carefully packed prior to shipment. Upon receiving, the packaging should be inspected for damages and the pump stored in a dry area.

INSTALLATION

H

It is recommended that the use of the pump be according to normative safety standards and also as per the precautions listed below.

PRELIMINARY CHECKS

H-1

Check that there has been no damage to the pump during transportation or storage. Both inlet and outlet ports should be carefully cleaned removing possible dust or residual packaging material. Verify that the available electrical power supply corresponds to the specification requirements.

POSITIONING

H-2

The pump can be mounted in any position. Fix it utilizing suitable screws corresponding to the antivibration mounts supplied.

⚠ WARNING: THE MOTOR IS NOT EXPLOSION PROOF. Do not install the pump where flammable vapours or gases may be present. Install it in an accessible place for inspection.

It is good practice to avoid any pump contact with water splashes possibly causing water seepage into the motor with high risk of internal oxidation and/or short circuit.

H-3

TUBING CONNECTIONS

- Prior to making any tube/hose connections, check that the inlet ports have no end caps;
- Do not position the pump at a height greater than 1,5m-4,9ft with respect to the minimum level of the fluid to be transferred. Damage may occur if this height is exceeded as the pump may not draw fluid. Make sure that the outlet tube is empty and without chokes;
- Avoid choking the inlet or outlet tubes so that efficiency is optimized. The use of an inlet filter is mandatory especially with fluids containing impurities (ASTM mesh 35). In this case frequent cleaning and maintenance of the filter is advisable. Utilize tubes and connection pieces that are resistant to the fluid types handled and avoid any possible environmental dispersion.

H-4

ELECTRICAL CONNECTION

The electrical installation must include a protection fuse which is suitably rated as indicated on the motor label and sized with reference to the chosen point of application.

WARRANTY EXPIRES IF NO FUSE IS UTILIZED

Always mount the anti vibration rubber fittings supplied with the pump kit. Their usage ensures a consistent reduction in noise and vibration levels.

Electrical cabling size should depend on the distance between pump and battery power supply.

Up to 4 m-13 ft length: AWG 14.

The use of undersized cabling can cause overheating of the electrical wiring and subsequent fire hazard. There will also be a voltage drop at the motor terminals with a consequent reduction in efficiency.

The flow rate value indicated on the motor label is obtained with a 13 mm-1/2 in, internal tube diameter. Tubes with inferior diameters will cause an increase in current with potential risk of motor overheating. On the outlet side it is advisable to use at least a short section flexible tubing.

To ensure the correct directional flow of the fluid as indicated by the arrow on the top plate, it is necessary to connect the positive pole (+) of the battery supply to the red wire on the motor end-cap and the negative pole (-) to the black wire. Electrical connections must be made using adequate terminal blocks and connectors ensuring a tight fitment of the electrical cables. Bad wiring can cause power losses and/or overheating of the cabling itself.

⚠ WARNING: it is the responsibility of the installation technician to ensure a correctly designed circuit installation fitted according to ABYC regulations. Environmental risks must be taken into account with the installation.

TROUBLESHOOTING

I

CHECK POINTS IF THE PUMP HAS STOPPED OR WILL NOT START

I-1

- Check the effectiveness of the battery power supply (voltage activity);
- Check if the fuse has blown;
- Check for any foreign matter present in-between the pump gear drives. To do this, disconnect the power supply and unscrew the four fixing screws, remove the front cover plate and inspect the chamber. Replace the cover plate in the same initial position after inspection;
- Avoid running the pump dry for more than a few minutes. Pumps found defective that have run dry in the absence of fluid are not covered by warranty;
- The average life span of the motor commutator brushes is approximately 2000 hours under normal operating conditions. Stoppages are possible due to brush wear and tear after such a time period.

WHY THE PUMP WILL NOT PRIME ITSELF?

I-2

- The pump is fitted at a height greater than 1,5 m - 4,9 ft above the fluid level;
- The pump has run dry for too long a period;
- Long periods of inactivity. In this case it is advisable to add liquid directly into the chamber before start-up. It is also advisable to add, before running the pump, a drop of lubricating oil inside the pump only;
- Air leak at the suction pipe due to the following reasons:
possible cuts in the pipe, inadequate hose clamps, malfunctioning of the filter due to defective/worn seals or filter clogged;
- Air leak at the front plate cover due to the following reasons:
Loose fixing screws, poor effectiveness of the seal;
- Faulty electrical cable connections;
- Presence of obstructions or restrictions in the suction or delivery pipes or the use of special devices(eg. automatic spray pistol or aqua-stop);
- Presence of liquid loops in the outlet tube.

GOOD PRACTICES ENSURING A WELL FUNCTIONING PUMP

I-3

No particular maintenance is required if the pump is utilized for the transfer of diesel fluids. If it is expected that the pump will not be used for a period of at least 30 days, especially in the case of usage with fresh or salty water, it is advisable to run fresh water through it and to then loosen the front plate screws. Upon re-use, run the pump briefly (a few seconds) and tighten the screws again. Check under conditions of maximum operating pressure that the motor current value is within the motor label specifications.

NORMAL MAINTENANCE

- Check frequently and keep the inlet filter clean;
- Check every month the chamber and keep clean from any foreign matter;
- Check every month that electrical wiring is in good condition;

INDICATORS THAT THE PUMP IS FUNCTIONING CORRECTLY

- Temperature of body and motor frame is within 140°F-158°F;
- Regular flow and constant noise levels;
- Amp-draw within the limits indicated in the technical details.

TO OPEN THE PUMP

It is recommended that a specialized service technician be consulted for any repair work or the replacement of worn out internal components, exclusively with original spare parts; During the warranty period, only by authorized Marco S.p.A. personnel, failing which the warranty will expire.

ENVIRONMENTAL DISPOSAL

Do not dispose of pumps into household waste: pumps that are no longer usable, must be collected separately and disposed of in an environmentally correct manner.

PACKAGING ENVIRONMENTAL DISPOSAL

The user is invited to effect a proper waste separation, in order to facilitate the recycling of the materials of which the packing is composed.

WARRANTY

1. The Warranty period is 2 years from date of purchase on production of the appropriate sales invoice.
2. Should the original sales invoice not be available, then the 2 year warranty period will be valid from production date.
3. The Warranty becomes null and void in the case of incorrect utilization or disregard of the instructions contained herein.
4. The Warranty only covers original production defects.
5. The Warranty does not cover any related installation costs involved.
6. Transport costs are refundable only in the case where warranty has been duly accepted by Marco Spa and they will be limited to the actual shipment costs between Marco Spa warehouse and the client's delivery address.
7. No credit notes or replacement items will be issued prior to the receipt and proper testing of any Marco goods that are deemed faulty.

EXPLODED VIEW

N

Pos.	Q.ty	Description
1	1	PUMP BODY
2	1	SEAL
3	2	ROD
4	1	GASKET
5	1	PUMP FRAME
6	1	ARMATURE
7	1	COMPENSATION SPRING
8	1	BALL BEARING
9	1	BRUSH HOLDER
10	1	O-RING
11	2	O-RING

Pos.	Q.ty	Description
12	2	WASHER
13	2	NUT
14	1	IDLE GEAR
15	1	KEY
16	1	DRIVING GEAR
17	1	O-RING
18	1	TOP PLATE
19	4	SCREW
20	2	TUBE OUTLET
21	2	O-RING
22	4	ANTIVIBRATION MOUNT

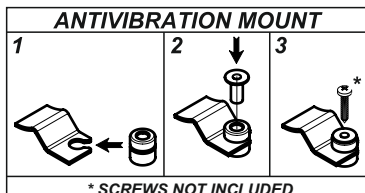
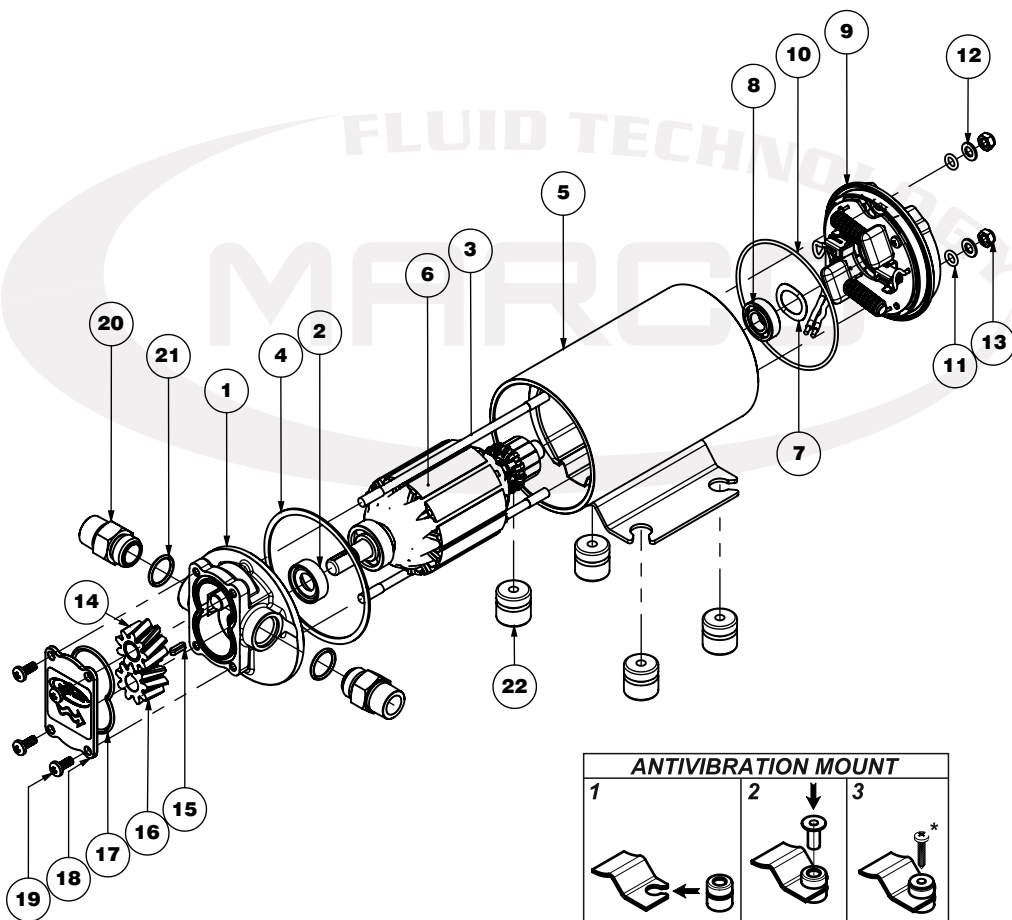

DIMENSIONS

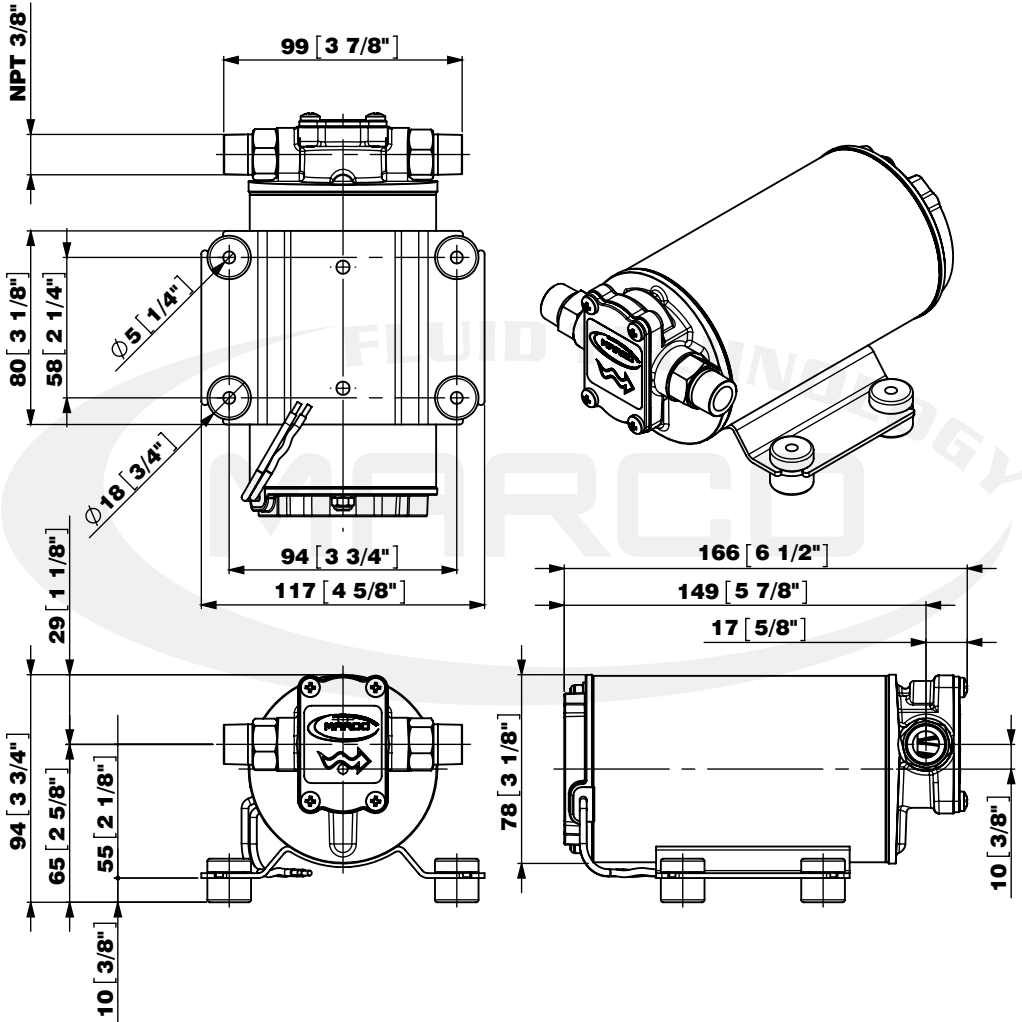

FLOW RATES DIAGRAM

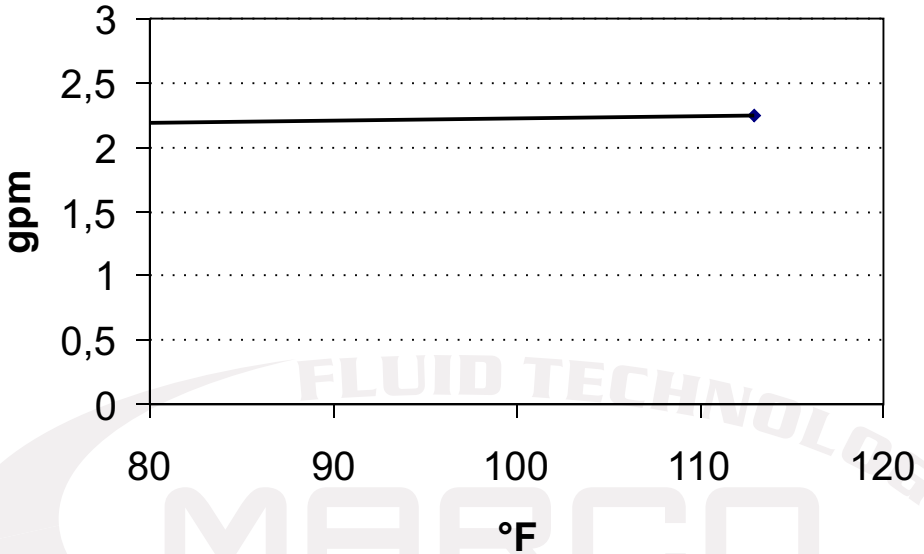

AMPERE-DRAW DIAGRAM

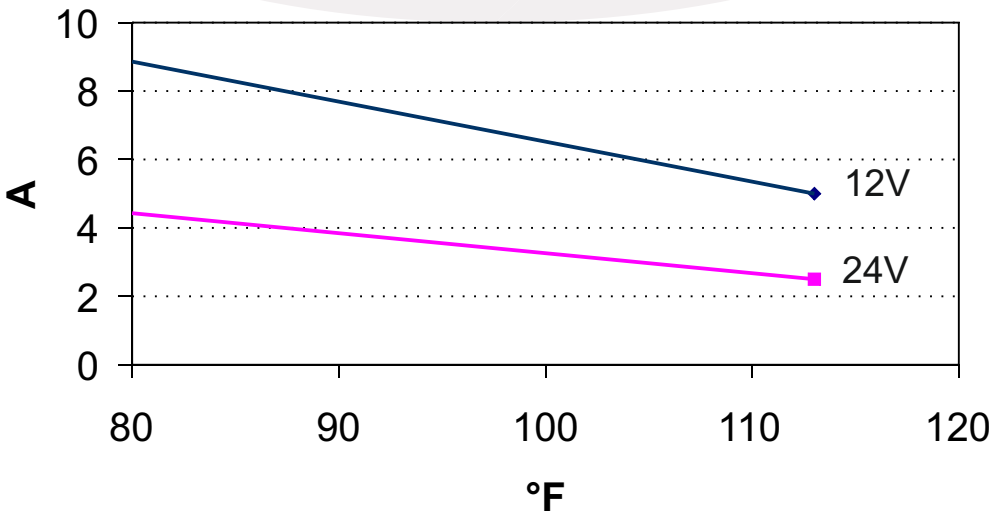



Associazione AIB
associazione
industriale
bresciana

E.C. DECLARATION OF CONFORMITY

We confirm that the product:

164 080 12 - UP6/OIL 12V Gear pump

164 080 13 - UP6/OIL 24V Gear pump

Is in conformity with the Directive 2004/108/EC (ex.89/336/EC) relating to Electromagnetic Compatibility.

This declaration is valid for all products which are produced in accordance with the technical documentation which is a part of this declaration. For verification of conformity with regard to Electromagnetic Compatibility the following standards are applied:

EN 55014-1

Electromagnetic compatibility.
Requirements for household appliances,
electric tools, and similar apparatus.
Part 1: Emission.

This declaration is given under the sole responsibility of:

MARCO S.P.A.
Via Mameli 10 - 25014 Castenedolo - Brescia - Italy
Tel. 030/2134.1 Fax 030/2134.300

NOTES

FLUID TECHNOLOGY

MARCO

Property of MARCO S.p.A reproduction prohibited. All rights reserved.

For further information visit our web site - www.marco.it

Marco S.p.A Via Mameli 10 - 25014 Castenedolo (Brescia) – Italy

tel. +39 030 2134.1 / Fax +39 030 2134.300