

Dimensions

Mechanical Seal

EVMU 3, 5, 10, 18

EVMUL 3, 5, 10, 18

Distributed by PumpBiz, Inc.  
 800-PumpBiz (786-7249)  
[www.PumpBiz.com](http://www.PumpBiz.com)

Mechanical Seal

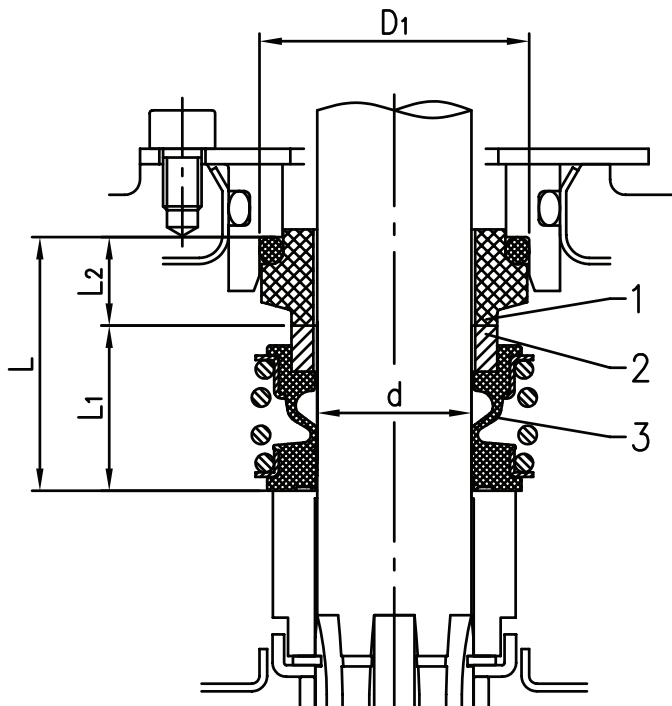

Pump Type	Size [inch]	Max. working pressure [PSI]	d [inch]	D <sub>1</sub> [inch]	L [inch]	L <sub>1</sub> [inch]	L <sub>2</sub> [inch]	Material			
								1 stationary seal ring	2 rotary seal ring	3 elastomer	spring
3-5	0.5	232	0.5	0.91	0.93	0.63	0.3	Carbon graphite	Silicon carbide	FPM	316Ti
		370									
10	0.63	232	0.63	1.06	1.06	0.67	0.39	Carbon graphite	Silicon carbide	FPM	316Ti
		370									
18	0.79	232	0.79	1.38	1.3	0.85	0.45	Carbon graphite	Silicon carbide	FPM	316Ti
		370									

### Dimensions

### Mechanical Seal

EVMUG 32, 45, 64

EVMUL 32, 45, 64

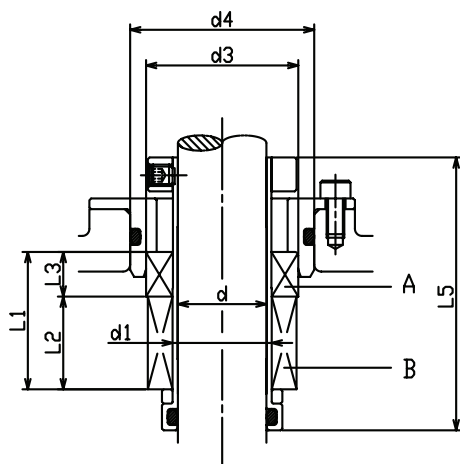

working pressure to 370 PSI

Standard Seal

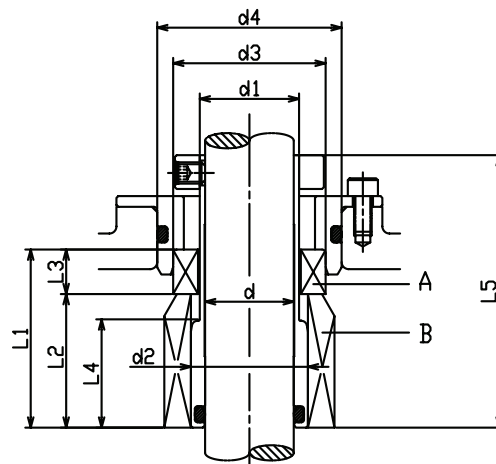

working pressure to 440 PSI

Standard Seal

Size (inch)	Max. working pressure (psi)	d (inch)	d1 (inch)	d2 (inch)	d3 (inch)	d4 (inch)	L1 (inch)	L2 (inch)	L3 (inch)	L4 (inch)	L5 (inch)	Material			
												A stationary seal ring	B rotary seal ring	elastomer	spring
1.102	232	0.984	1.102	-	1.693	2.047	1.535	1.043	0.492	-	2.894	Carbon graphite	Silicon Carbide	FPM	316 Ti
	370														
	440														

**Dimensions**

**Models EVMU(L)3  
EVMU(L)5**

Approximate Motor Dimensions C\*  
for 3 phase, TEFC, NEMA Motors

HP	Frame Size	C* Inches	Motor Wt LBS.
0.5	56C	9.29	19
0.75	56C	9.29	21
1	56C	9.29	23
1.5	143TC	9.92	30
2	145TC	10.08	33
3	145TC	11.18	45
5	184TC	13.80	69
7.5	184TC	15.30	88

*Note: C\* may vary slightly by manufacturer*

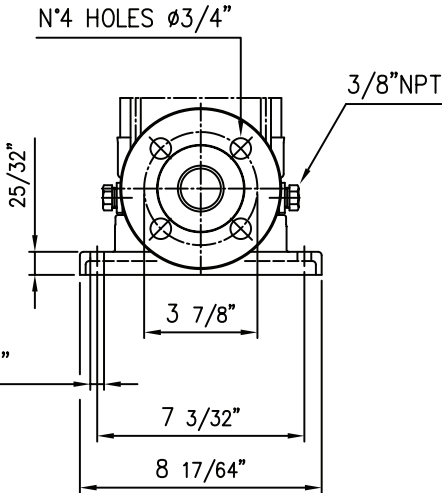
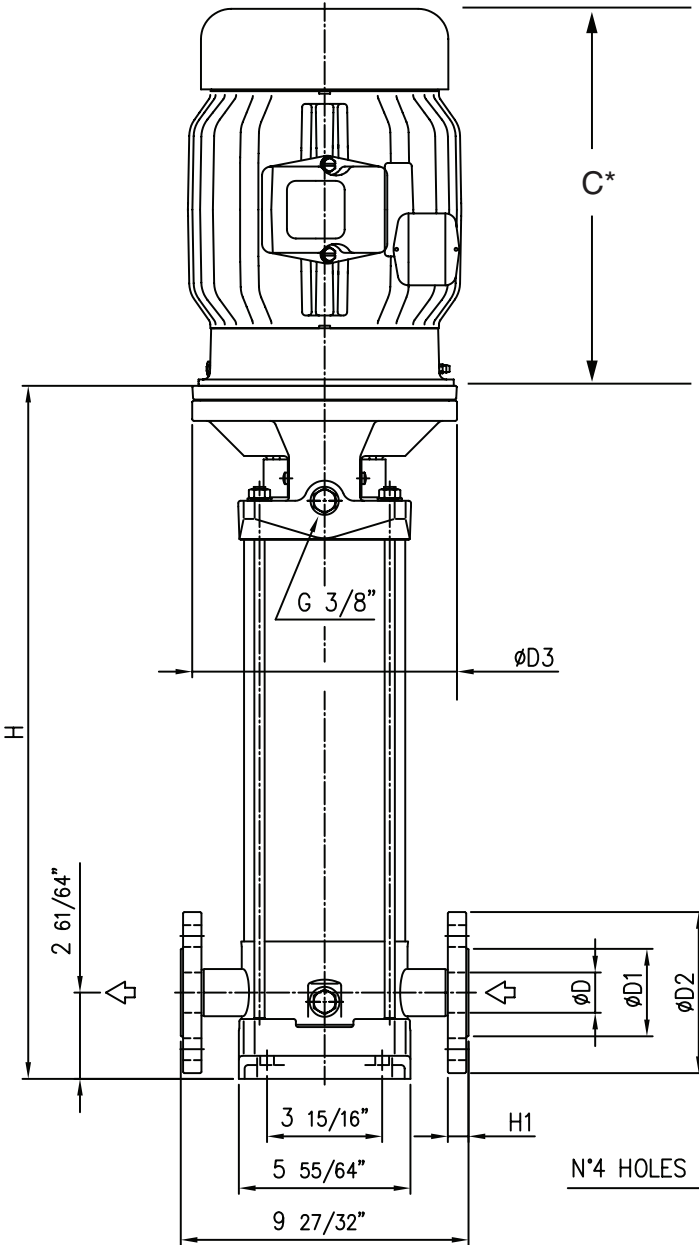

Flange Detail:

EVMU(L)3 250Lb. ANSI  
EVMU(L)5 250Lb. ANSI

## Model EVMU / EVMUL

## EBARA Stainless Steel Vertical Multistage

### Dimensions

Models EVMU(L)3  
EVMU(L)5

Pump Type EVMU(L)	HP	Motor Frame	Dimensions						Weight [lbs]
			D	D1	D2	D3	H	H1	
3 2	.5	56C	1 3/8"	2 63/64"	5 33/64"	6 39/64"	11 5/16"	23/32"	38.2
3 3	.75	56C	1 3/8"	2 63/64"	5 33/64"	6 39/64"	12 9/64"	23/32"	39.2
3 4	1	56C	1 3/8"	2 63/64"	5 33/64"	6 39/64"	12 31/32"	23/32"	40.3
3 5	1.5	143TC	1 3/8"	2 63/64"	5 33/64"	6 39/64"	13 55/64"	23/32"	41.4
3 6	1.5	143TC	1 3/8"	2 63/64"	5 33/64"	6 39/64"	14 11/16"	23/32"	43.5
3 7	2	145TC	1 3/8"	2 63/64"	5 33/64"	6 39/64"	15 17/32"	23/32"	43.9
3 8	2	145TC	1 3/8"	2 63/64"	5 33/64"	6 39/64"	16 23/64"	23/32"	44.3
3 9	3	145TC	1 3/8"	2 63/64"	5 33/64"	6 39/64"	17 3/16"	23/32"	45.9
3 11	3	145TC	1 3/8"	2 63/64"	5 33/64"	6 39/64"	18 27/32"	23/32"	44.6
3 12	3	145TC	1 3/8"	2 63/64"	5 33/64"	6 39/64"	19 43/64"	23/32"	46.1
3 13	3	145TC	1 3/8"	2 63/64"	5 33/64"	6 39/64"	20 57/64"	23/32"	49.1
3 15	5	184TC	1 3/8"	2 63/64"	5 33/64"	9 1/16"	22 57/64"	23/32"	55.6
3 18	5	184TC	1 3/8"	2 63/64"	5 33/64"	9 1/16"	25 3/8"	23/32"	63.5
5 2	.75	56C	1 3/8"	2 63/64"	5 33/64"	6 39/64"	11 7/8"	23/32"	41.7
5 3	1.5	143TC	1 3/8"	2 63/64"	5 33/64"	6 39/64"	13 1/32"	23/32"	42.8
5 4	2	145TC	1 3/8"	2 63/64"	5 33/64"	6 39/64"	14 9/64"	23/32"	44.8
5 5	2	145TC	1 3/8"	2 63/64"	5 33/64"	6 39/64"	15 15/64"	23/32"	46.1
5 6	3	145TC	1 3/8"	2 63/64"	5 33/64"	6 39/64"	16 23/64"	23/32"	47.4
5 7	3	145TC	1 3/8"	2 63/64"	5 33/64"	6 39/64"	17 55/64"	23/32"	49.2
5 8	3	145TC	1 3/8"	2 63/64"	5 33/64"	6 39/64"	18 61/64"	23/32"	50.5
5 10	5	184TC	1 3/8"	2 63/64"	5 33/64"	9 1/16"	21 33/64"	23/32"	55.8
5 11	5	184TC	1 3/8"	2 63/64"	5 33/64"	9 1/16"	22 5/8"	23/32"	58.2
5 12	5	184TC	1 3/8"	2 63/64"	5 33/64"	9 1/16"	23 23/32"	23/32"	59.7
5 14	7.5	184TC	1 3/8"	2 63/64"	5 33/64"	9 1/16"	25 59/64"	23/32"	64.8
5 16	7.5	184TC	1 3/8"	2 63/64"	5 33/64"	9 1/16"	28 5/32"	23/32"	67.7

Dimensions

Models EVMU(L)10  
EVMU(L)18

Approximate Motor Dimensions C\*  
for 3 phase, TEFC, NEMA Motors

HP	Frame Size	C* Inches	Motor Wt LBS.
1.5	143TC	9.92	30
3	145TC	11.18	45
5	184TC	13.80	69
7.5	184TC	15.30	88
7.5	213TC	15.18	99
10	215TC	15.26	122
15	215TC	16.39	143
20	256TC	16.32	221
25	284TSC	19.03	371

Note: C\* may vary slightly by manufacturer

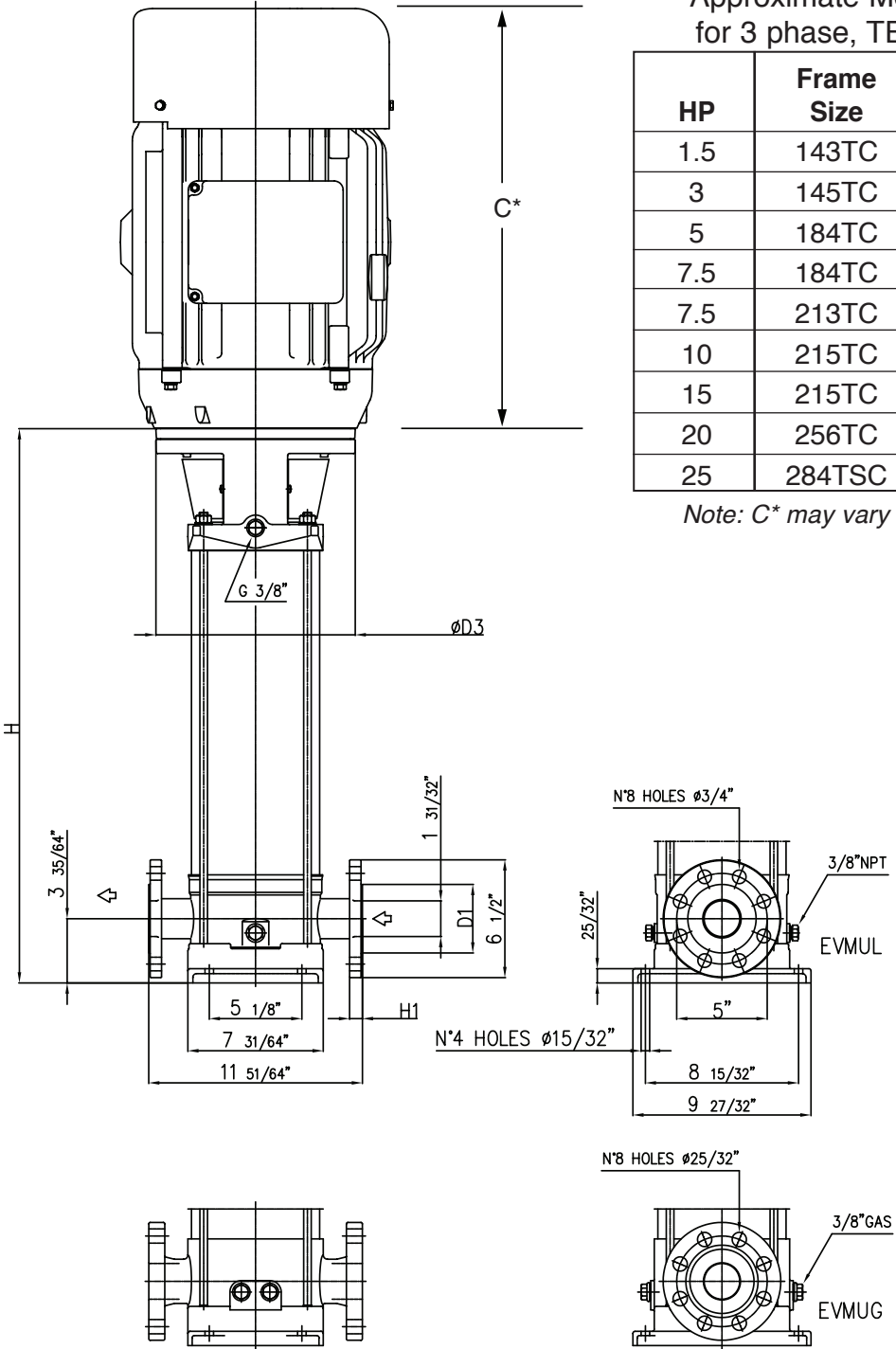

Flange Detail:

EVMU(L)10 250lb. ANSI  
EVMU(L)18 250lb. ANSI

Refer to page 819 for dimension details

**Model EVMU / EVMUL**

**EBARA Stainless Steel Vertical Multistage**

**Dimensions**

**Models EVMU(L)10**

**EVMU(L)18**

Pump Type EVMU(L)	HP	Motor Frame	Dimensions				Weight [lbs]
			D1	D3	H	H1	
10 2	1.5	143TC	4 1/64"	6 39/64"	14 1/64"	23/32"	130.9
10 3	3	145TC	4 1/64"	6 39/64"	15 13/64"	23/32"	138.2
10 4	3	145TC	4 1/64"	6 39/64"	16 49/64"	23/32"	149.8
10 5	5	184TC	4 1/64"	9 1/16"	18 13/16"	23/32"	152.8
10 6	5	184TC	4 1/64"	9 1/16"	20"	23/32"	160.1
10 8	7.5	184TC	4 1/64"	9 1/16"	22 3/8"	23/32"	192.1
10 10	7.5	213TC	4 1/64"	9 1/16"	24 3/4"	23/32"	196.6
10 12	10	215TC	4 1/64"	9 1/16"	27 7/64"	23/32"	242.2
10 14	15	215TC	4 1/64"	9 1/16"	29 41/64"	23/32"	254.3
10 16	15	215TC	4 1/64"	9 1/16"	32"	23/32"	279.1
18 2	5	184TC	4 1/64"	9 1/16"	15 9/16"	23/32"	182.9
18 3	7.5	184TC	4 1/64"	9 1/16"	17 41/64"	23/32"	190.2
18 4	7.5	184TC	4 1/64"	9 1/16"	19 7/32"	23/32"	190.2
18 5	10	215TC	4 1/64"	9 1/16"	20 25/32"	23/32"	236.4
18 6	15	215TC	4 1/64"	9 1/16"	22 9/16"	23/32"	258.8
18 7	15	215TC	4 1/64"	9 1/16"	24 9/64"	23/32"	271.0
18 8	15	215TC	4 1/64"	9 1/16"	25 45/64"	23/32"	278.3
18 10	20	256TC	4 1/64"	9 1/16"	28 55/64"	23/32"	329.3
18 11	25	284TSC	4 1/64"	11 1/32"	30 37/64"	23/32"	336.6

**Dimensions**

Models EVMUL32 1 – EVMUL32 4-3  
 EVMUL45 1-1 – EVMUL45 3  
 EVMUG32 1 – EVMUG32 4-3  
 EVMUG45 1-1 – EVMUG45 3

Approximate Motor Dimensions C\*  
 for 3 phase, TEFC, NEMA Motors

HP	Frame Size	C* Inches	Motor Wt LBS.
5	184TC	13.80	69
7.5	184TC	15.30	88
10	215TC	15.26	122
15	215TC	16.39	143
20	256TC	16.32	221

Note: C\* may vary slightly by manufacturer

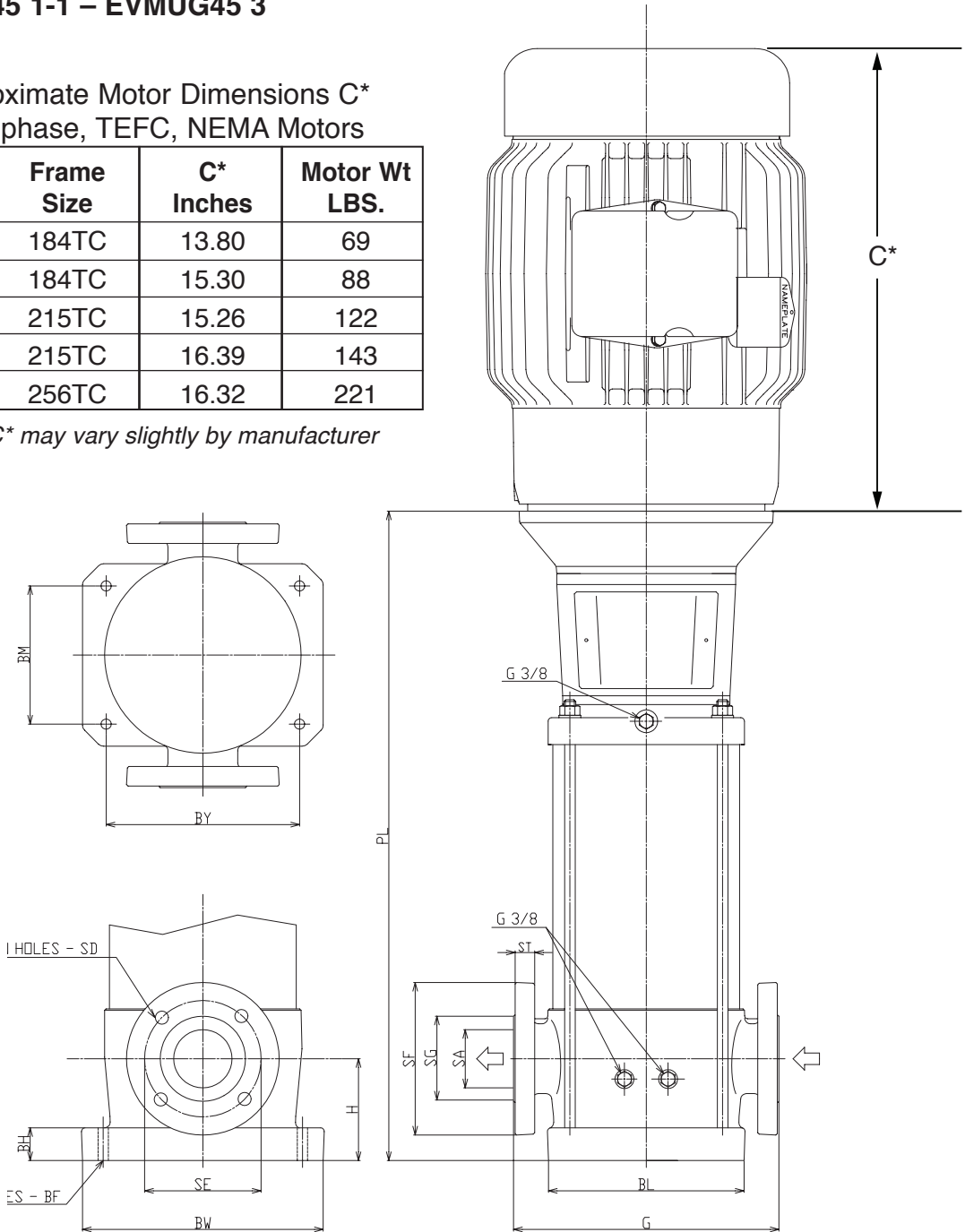

Flange Detail:

EVMU32 2 1/2" 150Lb. ANSI  
 EVMU45 3" 150Lb. ANSI

Refer to page 823 for dimension details.

**Dimensions**

**Models EVMUG64 1-1 – EVMUG64 3**  
**EVMUL64 1-1 – EVMUL64 3**

Approximate Motor Dimensions C\*  
 for 3 phase, TEFC, NEMA Motors

HP	Frame Size	C* Inches	Motor Wt LBS.
10	215TC	15.26	122
15	215TC	16.39	143
20	256TC	16.32	221
25	284TSC	19.03	371
30	286TSC	19.03	403
40	324TSC	23.39	422

*Note: C\* may vary slightly by manufacturer*

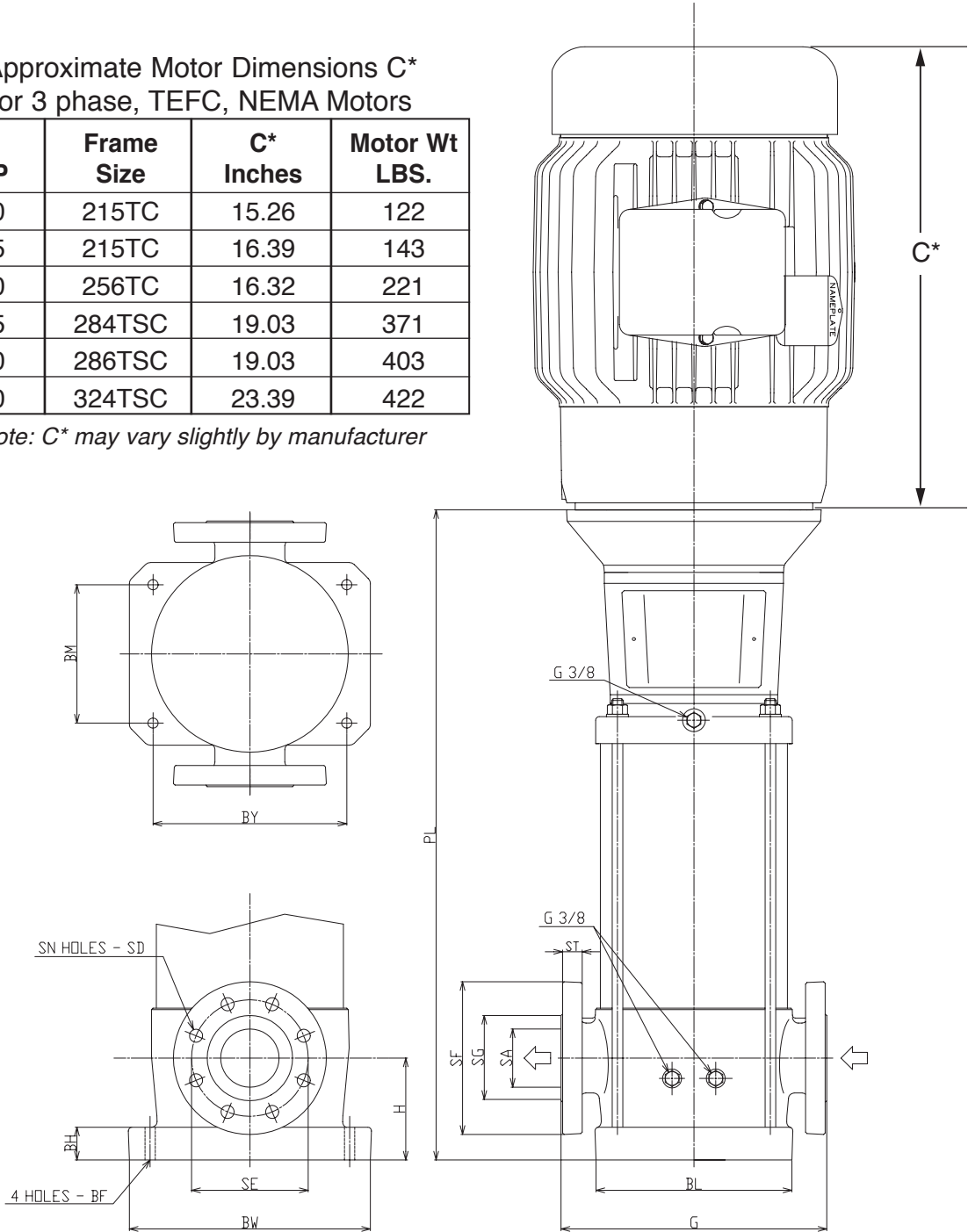

Flange Detail:

EVMU64 4" 150Lb. ANSI

**Refer to page 823 for dimension details.**



**Dimensions**

- Models EVMUG32 5 – EVMUG32 10-1  
 EVMUG45 4-1 – EVMUG45 7-2  
 EVMUG64 4-2 – EVMUG64 4  
 EVMUL32 5 – EVMUL32 10-1  
 EVMUL45 4-1 – EVMUL45 7-2  
 EVMUL64 4-2 – EVMUL64 4

Approximate Motor Dimensions C\*  
 for 3 phase, TEFC, NEMA Motors

HP	Frame Size	C* Inches	Motor Wt LBS.
20	256TC	16.32	221
25	284TSC	19.03	371
30	286TSC	19.03	403
40	324TSC	23.39	422
50	326TSC	23.39	962

Note: C\* may vary slightly by manufacturer

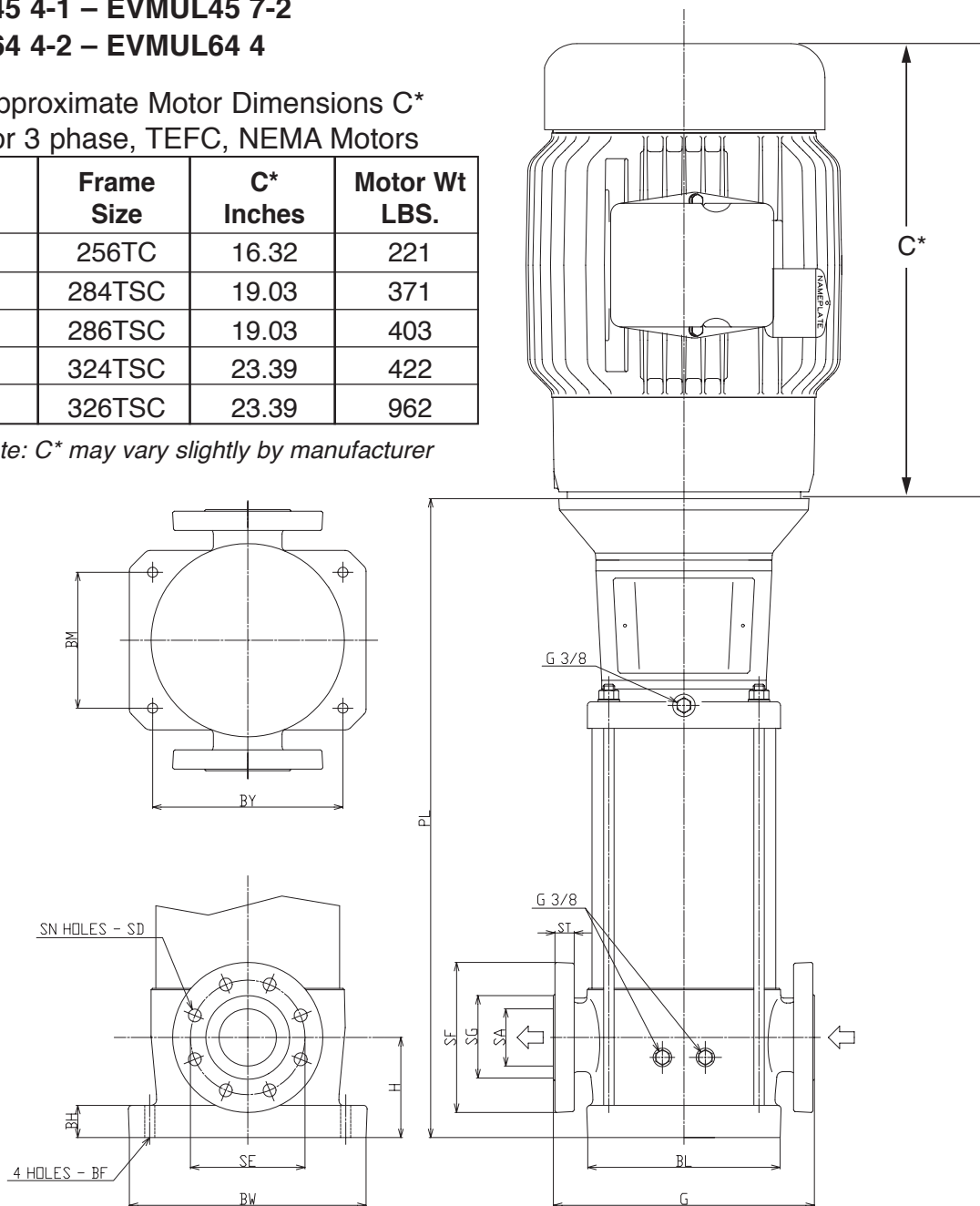

Flange Detail:

- EVMU32 2½" 300Lb. ANSI
- EVMU45 3" 300Lb. ANSI
- EVMU64 4" 300Lb. ANSI

Refer to page 823 for dimension details.

**Dimension Table**

Pump Type					Dimensions (inches)												
Model	HP	Weight Lbs. †	Motor Frame*	PL	H	G	ST	SA	SG	SF	SD	SN					
32 1	5	117	184TC	18 3/16	4 9/64	12 9/32	54/64	2 9/16	4 21/64	7	3/4-10UNC	4					
32 2-2	7 1/2	126	184TC	20 19/32													
32 3-2	10	170	215TC	22 31/64													
32 3	15	172	215TC	27 41/64													
32 4-3	15	176	215TC	29 17/32													
32 5	20	194	256TC	31 27/64													
32 6	25	200	284TSC	33 7/64													
32 7	30	207	286TSC	35													
32 8-3	30	225	286TSC	36 57/64													
32 9	40	240	324TSC	39 3/8													
32 10-1	40	247	324TSC	41 17/64													
45 1-1	7 1/2	148	184TC	21 29/64	5 33/64	14 3/8	15/16	3 5/32	4 23/32	7 1/2	25/32	4					
45 1	10	152	215TC	21 29/64													
45 2-1	15	192	215TC	29 29/64													
45 3-2	20	207	256TC	32 9/32													
45 3	25	207	284TSC	32 2/32													
45 4-1	30	229	286TSC	34 59/64													
45 5	40	260	324TSC	38 11/32													
45 6	50	276	326TSC	41 3/16													
45 7-2	50	287	326TSC	44 1/64													
64 1-1	10	179	215TC	21 29/64			5 33/64			14 3/8		1 1/32	3 15/16	5 33/64	9	25/32	8
64 1	15	201	215TC	26 5/8													
64 2-1	20	213	256TC	29 29/64													
64 2	25	214	284TSC	29 1/4													
64 3-2	30	221	286TSC	32 3/32													
64 3	40	223	324TSC	32 11/16													
64 4-2	40	245	324TSC	35 33/64													
64 4	50	251	326TSC	35 33/64													
								1 21/64				10			29/32		

Pump Type				Dimensions (inches)						
Model	HP	Motor Frame*	SE	BM	BY1	BL	BW	BF	BH	
32 1	5	184TC	5 1/2	6 11/16	9 29/64	8 17/64	11 1/32	35/64	1 3/8	
32 2-2	7 1/2	184TC								
32 3-2	10	215TC								
32 3	15	215TC								
32 4-3	15	215TC								
32 5	20	256TC	5 7/8							
32 6	25	284TSC								
32 7	30	286TSC								
32 8-3	30	286TSC								
32 9	40	324TSC								
32 10-1	40	324TSC								
45 1-1	7 1/2	184TC	6	7 31/64	10 15/32	9 57/64	13 1/32	35/64	1 49/64	
45 1	10	215TC								
45 2-1	15	215TC								
45 3-2	20	256TC								
45 3	25	284TSC								
45 4-1	30	286TSC								6 5/8
45 5	40	324TSC								
45 6	50	326TSC								
45 7-2	50	326TSC								
64 1-1	10	215TC								
64 1	15	215TC								
64 2-1	20	256TC								
64 2	25	284TSC								
64 3-2	30	286TSC								
64 3	40	324TSC	7 7/8							
64 4-2	40	324TSC								
64 4	50	326TSC								