

Distributed by PumpBiz, Inc.
www.PumpBiz.com
800-PumpBiz (786-7249)

Model EVMU /EVMUG / EVMUL

Stainless Steel Vertical Multistage



Operating Instructions, Installation & Maintenance Manual



EBARA Fluid Handling



Certified to
NSF/ANSI 61, ANNEX G

EBARA International Corporation

Instructions and Operation

Section	Page
Manufacturer Information	2
1 – General Information and Warnings	2
2 – Specifications	3
3 – Pump Checks & Installation	6
4 – Operation	8
5 – Motor Installation on Bare Pump	10
6 – Removing Motor from Complete Pump	11
7 – General Pump Maintenance and Disassembly Instructions	12
Torque Specifications	21
Sectional View	22

Manufacturer Information

EBARA Fluid Handling
1651 Cedar Line Drive
Rock Hill, SC 29730



Phone: (803) 327-5005
Fax: (803) 327-5097

e-mail: info@pumpsebara.com
web site: www.pumpsebara.com

* NSF/ANSI 61 Annex G listed models: EVMU3-18, EVMUL all models 3-64

Section 1 – General Information and Warnings

- 1.1 The user must comply with all local and national regulations that apply to the installation and operation of electric pumps. Operation of the EVMU pump must be compatible with the construction of the pump as shown in the **SPECIFICATION** section of these instructions.

 Warning	
 	<p>Before any work is performed on the EVMU pump, care should be taken to ensure that electric power is disconnected to the motor to prevent electric shock or premature starting which could cause damage to persons, things or the pump.</p> <p>Before starting the EVMU pump, make sure that all cables, electrical connections and controls are in perfect working order and properly grounded. Improper installation can result in serious or even mortal accidents to persons.</p> <p>Any electrical work should be preformed by a licensed electrician.</p>

- 1.2 EVMU pumps with motor installed tend to be top heavy, care should be taken in handling and transporting to prevent damage or injury caused by the pump falling over.

Instructions and Operation

Section 2 – Specifications

⚠ CAUTION

Be careful not to exceed the given specifications in the use of your products.

Models EVMU 3, 5, 10, 18
EVMUL 3, 5, 10, 18

Size	EVMU	EVMUL
Suction	ANSI raised face 1 1/4" for EVMU 3 and 5 2" for EVMU 10 and 18	
Discharge	ANSI raised face 1 1/4" for EVMU 3 and 5 2" for EVMU 10 and 18	
Range of HP	1/2 to 25HP	
Range of Performance Capacity Head	at 3450 RPM 4 to 118 GPM 27 to 830 feet	
Liquid handled Type of liquid Temperature Working pressure	Clean water (<i>for other clean liquids, consult factory</i>) 5 to +248 F (-15 to 120 C) 370 PSI (25 Bar) max.	
Materials Impeller Intermediate casing Bottom casing Casing cover Outer casing Shaft Liner ring Motor bracket Base Pump Bearing Shaft Seal Mechanical seal	AISI 304 AISI 304 AISI 304 AISI 304 AISI 304 AISI 316 Cast iron/304 Cast iron/304	AISI 316 AISI 316 AISI 316 AISI 316 AISI 316 AISI 316 Cast iron/316 Cast iron/316 Sealed ball bearing/tungsten carbide Silicon/Carbide/Carbon/FPM
Motor Type Speed Three Phase	NEMA C/TC/TSC frame 60 Hz, 3450 RPM (2 poles) 208-230/460V	<i>Consult factory for optional motor types</i>
Direction of Rotation	Clockwise when viewed from motor end	
Test standard	ISO 9906 annex A	

Instructions and Operation

Section 2 – Specifications *(continued...)*

Models EVMUG 32, 45, 64
EVMUL 32, 45, 64

	EVMUG	EVMUL
Size		
Suction	ANSI raised face 2½" for EVMUG32 3" for EVMUG45 4" for EVMUG64	
Discharge	ANSI raised face 2½" for EVMUG32 3" for EVMUG45 4" for EVMUG64	
Range of HP	5 to 50HP	
Range of Performance	at 3450 RPM	
Capacity	66 to 390 GPM	
Head	44 to 930 feet	
Liquid handled		
Type of liquid	Clean water <i>(for other clean liquids, consult factory)</i>	
Temperature	5° to +248°F (-15° to 120°C)s	
Working pressure	to 440 PSI (30 Bar) max. <i>(see page 813 for specifics)</i>	
Materials		
Impeller	AISI 304	AISI 316
Intermediate casing	AISI 304	AISI 316
Bottom casing	Cast iron	AISI 316
Casing cover	Cast iron	AISI 316
Outer casing	AISI 304	AISI 316
Shaft	AISI 316	AISI 316
Liner ring	PTFE/AISI 316	
Motor bracket	Cast iron	Cast iron/316
Base	Cast iron	Cast iron/316
Pump Bearing	Thrust Bearing: Sealed Ball Bearing Radial Bearing in wet end: Tungsten Carbide	
Shaft Seal		
Mechanical seal	Silicon/Carbide/Carbon/FPM <i>(see page 815 for construction details)</i>	
Motor		
Type	NEMA TC/TSC frame	<i>Consult factory for optional motor types</i>
Speed	60 Hz, 3450 RPM (2 poles)	
Three Phase	208-230/460V	
Direction of Rotation	Clockwise when viewed from motor end	
Test standard	ISO 9906 annex A	

Instructions and Operation

Model Designation

Models EVMU 3, 5, 10, 18
EVMUL 3, 5, 10, 18

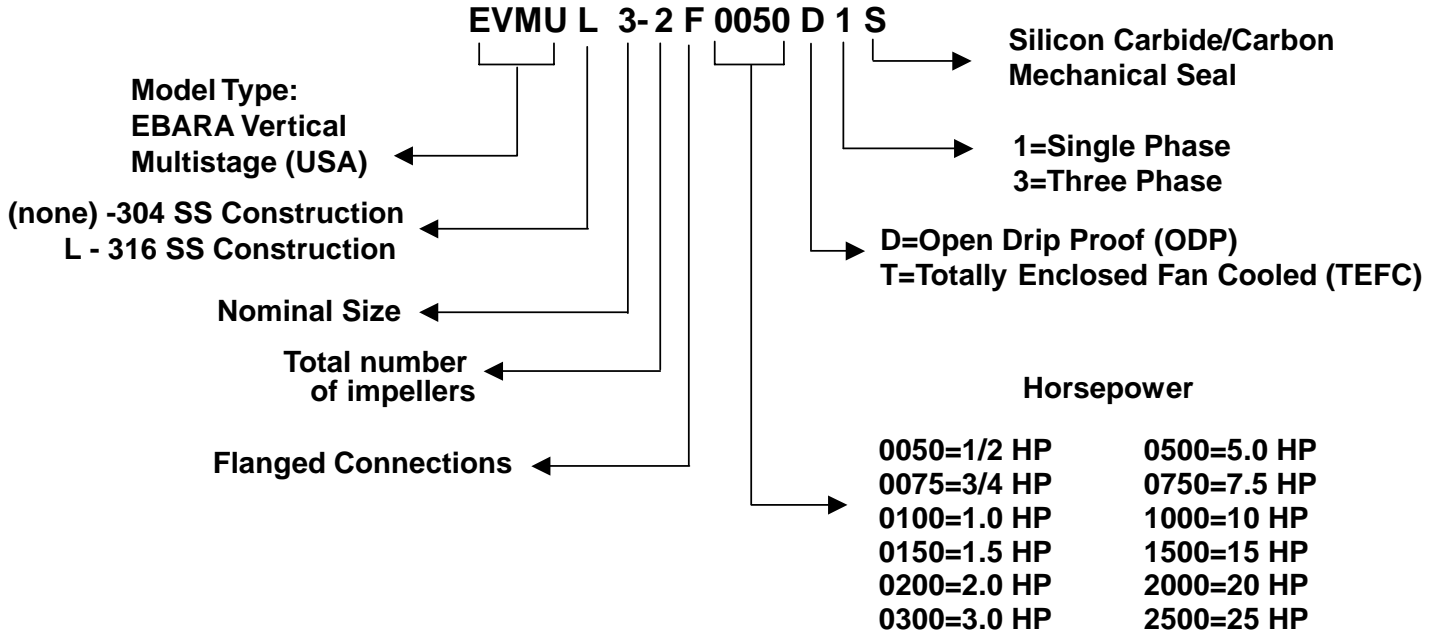

Models EVMUG 32, 45, 64
EVMUL 32, 45, 64

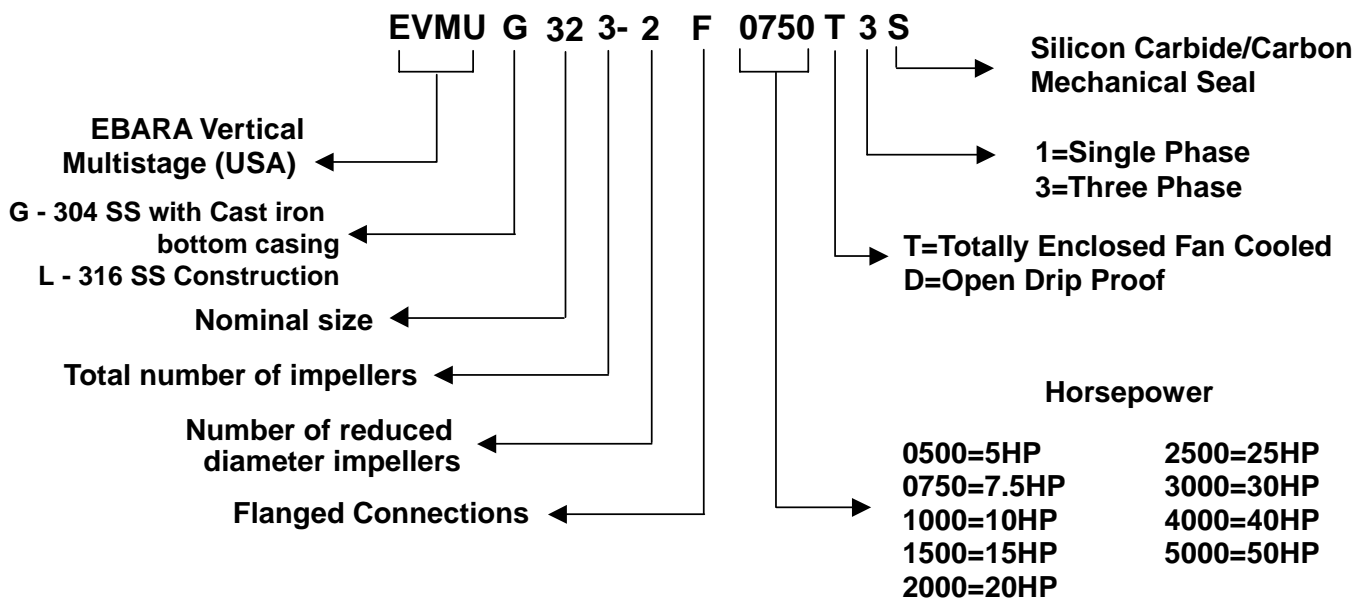

Instructions and Operation

Section 3 – Pump Checks and Installation

- 3.1 Always check to make sure pump was not damaged in shipment before accepting delivery. If damage is evident, a claim should be filed with the carrier at that time.
- 3.2 Always check the pump label against the requirement to make sure you are installing the proper pump specified for the job.
- 3.3 Make sure that the pump suction, marked by a sticker, is connected to the liquid source and that the discharge, similarly marked, is connected to the discharge line.

⚠ CAUTION

On three phase motor installations, always check for proper motor rotation prior to starting by jogging the motor. Shaft rotation must turn clockwise when viewed from the top of the motor.

Make sure the motor is correctly wired, refer to instructions on motor name plate.

- 3.4 Make sure that the pump base is firmly secured to a solid flat surface and that the suction and discharge lines are aligned and properly supported to prevent pipe strain on the pump.
- 3.5 Ensure that the suction and discharge gaskets are properly installed to prevent leaks and that they do not restrict the flow to or from the pump.

Standard ANSI mating flanges should be used to connect the pump to the piping. Suction and discharge piping should be no smaller than the respective pump port sizes.

- 3.6 Isolation valves should be installed on both the suction and discharge side of the pump in the event service of the pump is required.
- 3.7 Provide adequate space and ventilation around the pump for service and motor cooling.

⚠ WARNING

Use standard plumbing practices to ensure unnecessary line losses, cavitation and prevent air lock.

- 3.8 If the installation of the motor is necessary, refer to section 5 for instructions.

Instructions and Operation

! CAUTION

EXTREME CAUTION SHOULD BE USED IF PRIMING THE PUMP IN THIS MANNER IN A HOT WATER APPLICATION.

3.9 Priming the Pump

Completely prime the pump by removing the vent plug (212).

Using a funnel, fill the pump body with water until it overflows and replace plug.

Alternatively for installations with positive suction heads, close the discharge valve and remove the vent plug.

Open the suction valve until liquid flows out of the vent plug opening and then replace the vent plug securely and open discharge valve.

- 3.10** It is recommended that a bleed valve be installed in discharge line or in a line from the vent port to the reservoir. This will allow the pressure in the pump to be relieved for service.

! CAUTION

INSTALLING A BLEED VALVE IS ESPECIALLY NECESSARY IN HOT WATER APPLICATIONS TO PREVENT INJURY.

- 3.11** Pipe, valves and fittings must have a pressure rating equal to or greater than the maximum system pressure.

- 3.12** A bypass or pressure relief valve should be installed in the discharge line if there is any possibility the pump may operate against a closed valve in the discharge line.

Minimum flow is required for proper cooling and lubrication of the pump without which, damage and premature failure will occur.

Minimum Pumping Rate

Model	Minimum Flow Rate
EVMU 3	3.3 GPM
EVMU 5	6.7 GPM
EVMU 10	8 GPM
EVMU 18	11 GPM
EVMU 32	61 GPM
EVMU 45	112 GPM
EVMU 64	149 GPM



Instructions and Operation

Section 4 – Operation

- 4.1 Make sure that the system is properly installed and primed as instructed in section 3.
- 4.2 **STARTING-** When the pump is up to operating speed, open the discharge valve to obtain desired capacity or pressure.

! WARNING

DO NOT ALLOW THE PUMP TO RUN WITH THE DISCHARGE VALVE TIGHTLY CLOSED. IF THE PUMP RUNS FOR AN EXTENDED PERIOD OF TIME WITHOUT LIQUID BEING DISCHARGED, THE LIQUID IN THE PUMP CASE CAN GET EXTREMELY HOT CAUSING SEVERE DAMAGE TO THE PUMP AND POSSIBLY CAUSE INJURY TO PEOPLE.

- 4.3 Check to make sure all electric connections are correct.

! WARNING

OPERATING THE PUMP WITHOUT THE GUARDS IN PLACE CAN CAUSE PHYSICAL INJURY.

- 4.4 Apply power to the motor.

Check motor rotation. Rotation should be clockwise when viewed from the top.

Check that the noise, vibration, pressure, voltage and amps are at normal levels.

! WARNING

EVMU pumps are designed for continuous and normal off/on operation.

RAPID CYCLING CAN CAUSE HIGH HEAT AND LOADING THAT CAN CAUSE DAMAGE TO THE PUMP OR MOTOR.

- 4.5 Please refer to the motor manufacturer specifications for starts per hour.

Instructions and Operation

Maintenance and Service

For maintenance and service for each specific EVMU model, please refer to the section as indicated in the table below.

Pump Model	Install motor	Remove motor from pump	Replace mechanical seal	Replace mechanical seal & hydraulic seal
EVMU3 2 – EVMU 3 13	5A	6A	7A	7B
EVMU3 15 – EVMU3 18	5B	6B	7C	7D
EVMU5 2 – EVMU5 6	5A	6A	7A	7B
EVMU5 7 – EVMU5 16	5B	6B	7C	7D
EVMU10 2 – EVMU 10 3	5A	6A	7A	7B
EVMU10 4 – EVMU 10 16	5B	6B	7C	7D
EVMU18 2	5A	6A	7A	7B
EVMU18 3 – EVMU 18 11	5B	6B	7C	7D
EVMU 32 1	5A	6A	7A	7B
EVMU 32 2-2 EVMU32 3-2	5B	6B	7C	7D
EVMU 32 3 - EVMU 32 10-1	5B	6B	7E	7F
EVMU45 1-1 - EVMU45 1	5B	6B	7C	7D
EVMU45 2 - EVMU45 7-2	5B	6B	7E	7F
EVMU64 1-1	5B	6B	7C	7D
EVMU64 1 - EVMU64 4	5B	6B	7E	7F

Instructions and Operation

Section 5 – Motor Installation on Bare Pump

! WARNING

When lifting the pump/ motor, use appropriate crane (or hoist), check position and tightness of lift system so that weight of the pump is not UNBALANCED.

Failure to observe this precaution can result in serious accidents.

5A Procedure for mounting motors for the following models:

EVMU3 2 – EVMU3 12

EVMU10 2 – EVMU10 3

EVMU5 2 – EVMU5 6

EVMU18 2

EVMU32 1

- (1) Follow general safety and electrical instructions on the motor name plate.
- (2) Remove coupling guard from the pump end.
- (3) Carefully loosen the screws on the coupling.
- (4) Position the motor vertically over the pump with the keyways lined up on the motor and the pump then lower motor into place. If necessary rotate the motor so that the mounting bolt holes line up with the corresponding holes in the pump bracket.
- (5) Insert the mounting bolts and tighten firmly using a crisscrossing pattern.
- (6) Using two screwdrivers, lever between the motor bracket and the coupling raise the pump shaft until it touches the motor shaft. Now tighten the coupling screws to secure the motor and pump shaft into position.
- (7) Rotate the coupling to assure that the pump turns freely. If rubbing occurs loosen the coupling screws on the motor side and repeat step (5).
- (8) Be sure to re install the coupling guards

5B Procedures for mounting motors for the following models:

EVMU3 13- EVMU 3 18

EVMU 32 All Sizes (Except EVMU32 1)

EVMU5 7 – EVMU 5 17

EVMU 45 All sizes

EVMU10 4 – EVMU 1016

EVMU 64 All Sizes

EVMU18 3 – EVMU 18 11

- (1) Follow general safety and electrical instructions on the motor name plate.
- (2) Attach a strong sling or chains to the motor lifting lugs or eyebolts to ensure that the motor is balanced when lifted vertically.
- (3) Position the motor, shaft down, above the pump assembly.
- (4) Apply a thin coat of anti-seize to the motor shaft and to the inside of the coupling.
- (5) Ensure that the motor key has been placed firmly into the motor shaft keyway.



Instructions and Operation

- (6) Align the motor key and keyway with the coupling keyway and slowly lower the motor into position ensuring that the key slides into the coupling keyway.
- (7) Prior to lowering the motor completely, rotate the motor so that the mounting holes are aligned with the holes in the motor support.
- (8) Insert the four motor bolts into the proper holes and tighten evenly using an alternating crossing pattern to ensure proper alignment.

Section 6 – Removing Motor from Complete Pump**⚠ WARNING**

For any removal or installation procedures, always disconnect the power first.

Failure to observe this precaution can result in serious accidents.

⚠ CAUTION

Extreme caution should be exercised in this operation since the pump may be under system pressure at this point. Before proceeding with the removal of the motor be sure to relieve the system pressure in the pump.

Use a pressure bleed valve in hot water applications where water temperature could cause physical injury.

6A Removing the motor from models:

EVMU3 2 – EVMU3 12

EVMU10 2 – EVMU10 3

EVMU5 2 – EVMU5 6

EVMU18 2

EVMU 32 1

- (1) Following general safety and electrical instructions, disconnect the power to the motor and remove power cords.
- (2) Loosen and remove the four motor bolts.
- (3) Attach a strong sling or chains to the motor lifting lugs or eyebolts to ensure that the motor is balanced when lifted vertically.
- (4) Remove the coupling guards
- (5) Loosen, but do not remove the coupling bolts
- (6) Slowly lift the motor off the pump assembly ***being careful to retain the shaft key***. If the motor does not slide easily out of the coupling do not raise the pump into the air, dropping the pump end can cause damage. Fix the pump base to the floor or bench and lift motor again.



Instructions and Operation

6B Removing the motor from models:

EVMU3 13- EVMU 3 18	EVMU 32 All Sizes (Except EVMU32 1)
EVMU5 7 – EVMU 5 17	EVMU 45 All sizes
EVMU10 4 – EVMU 1016	EVMU 64 All Sizes
EVMU18 3 – EVMU 18 11	

- (1) Following general safety and electrical instructions, disconnect the power to the motor and remove power cords.
- (2) Loosen and remove the four motor bolts.
- (3) Attach a strong sling or chains to the motor lifting lugs or eyebolts to ensure that the motor is balanced when lifted vertically.
- (4) Slowly lift the motor off the pump assembly ***being careful to retain the shaft key***. If the motor does not slide easily out of the coupling do not raise the pump into the air, dropping the pump end can cause damage. Fix the pump base to the floor or bench and lift motor again.

Section 7 – General Pump Maintenance and Disassembly Instructions

Disassembly Tips

- Before beginning, it is recommended that tape or some other method of marking be used to make markings on the outer “can” assembly to indicate orientation, such as “top” and “bottom”.
- Next, make corresponding alignment markings that indicate where the bottom of the can and lower casing assembly meet. Also make another marking to indicate where the top of the can and lower portion of the cast iron motor support meet.
- Always inspect for damage of other components and clean any debris that you may find during maintenance procedures.
- Cross sectional views of the pumps are a good reference for these procedures and can be found starting on page 22.

7A Replacing the Mechanical Seal

EVMU3 2 – EVMU3 12	EVMU10 2 – EVMU10 3
EVMU5 2 – EVMU5 6	EVMU18 2
EVMU 32 1	

- (1) Isolate the pump by closing isolation valves on the suction and discharge lines.

BEFORE PROCEEDING TO STEP 2, PLEASE READ THE CAUTION BLOCK BELOW.

⚠ CAUTION

Extreme caution should be exercised in this operation since the pump is under system pressure at this point.

Relieve pressure before performing work on the pump.

Use a pressure bleed valve in hot water applications where water temperature could cause physical injury.

Instructions and Operation

- (2) Carefully relieve the pressure in the pump by opening the vent or drain plugs.
- (3) Remove the motor as detailed in Section 6A.
- (4) Remove the pump coupling bolts (120/5) and remove the coupling.
- (5) Remove shaft pin (131-1).
- (6) Remove the 4 socket head screws (120-3) from the stationary mechanical seal seat (111-3). Remove the seal seat and stationary seal. Press the old stationary seal assembly out of the stationary seal housing (111-3) The stationary seat is rubber o-ring mounted.

NOTE: EVMU32 1 will have a cartridge type mechanical seal. The rotating and stationary pieces of the seal will **all** be removed in this step, proceed to step 20.

- (7) Loosen and remove four tie rod nuts (128-1).
- (8) Gently tap upward on the base of the motor bracket (162) with a soft mallet to loosen the fit. Remove the motor bracket.
- (9) Remove the old rotating seal assembly by lifting vertically off the pump shaft.
Do not remove the shaft sleeve that is below the rotating assembly.
- (10) Remove the outer casing (007), remove the o-rings (115-1) from the top and bottom of the outer casing.
- (11) Slide the rotating seal assembly onto the shaft taking care not to scratch or touch the seal face. Apply a small amount of non-petroleum based lubricant on the inside of the rotating assembly. (i.e. dish soap, or Dow Corning #4 lubricant or similar). If touching the seal face is necessary, gently wipe with a clean soft tissue.
- (12) Push the assembly into place on the shaft, seating the rubber boot snugly.
- (13) Carefully, press the stationary seal assembly into the stationary seal housing (111-3) Be sure that the stationary seal is evenly seated.
- (14) Using a new outer casing o-ring (115-1) apply a light film of lubricant such as Dow corning #4 or similar to the o-ring and place it in the lower o-ring groove in the outer casing (007). Ensure that it is seated smoothly and evenly in the groove.
- (15) Place the outer casing (007) over the entire assembly and into the bottom casing (006). The outer casing may not seem to seat at this time, but the tie rods will be tightened in a later step, which will complete the seating of the outer casing (007).
- (16) Using a new outer casing o-ring (115/1), apply a light film of lubricant such as Dow Corning #4, or similar, to the o-ring and place it into the o-ring groove on the upper pump body (007) ensuring that it is seated smoothly into the o-ring groove at the top of the outer casing (007).



Instructions and Operation

- (17) Carefully place the motor bracket (162) over the pump shaft and the tie rods and onto the outer casing.
- (18) Replace the tie rod washers and nuts onto the tie rods finger tight.
- (19) Commence staggered tightening of the tie rod nuts to ensure even distribution of pressure and proper seating of the motor bracket onto the pump casing (007). Tighten all nuts to fit snugly. See torque specifications, page 21.
- (20) Slide the stationary seal seat (111-3) assembly over the shaft and into place. Secure the assembly by installing and tightening the 4 socket head screws (120-3).
- (21) Re-install the shaft pin (131-1).
- (22) Re-install the coupling by sliding one half and then the other half of the coupling over the shaft pin. Install the bolts in the lower half of the coupling tightening only until the shaft pin is secured in place and the coupling will not fall down the shaft. Final tightening of the coupling bolts will occur upon motor installation.
- (23) For reinstallation of the motor, see Section 51A.

7B – Replacement of Pump Hydraulic Assembly

EVMU3 2 – EVMU3 12
EVMU5 2 – EVMU5 6
EVMU 32 1

EVMU10 2 – EVMU10 3
EVMU18 2

- (1) Remove the old mechanical seal assembly and the outer casing as detailed in Section 7A, steps 1-10.
- (2) Remove the old hydraulic assembly.
- (3) Ensure that the proper replacement hydraulic (stack) assembly has been selected and provided for the pump.
- (4) Lift the replacement hydraulic (stack) assembly and place it onto the bottom casing (006) ensuring that it is seated properly. The bottom impeller should slip into the casing wear ring.
- (5) Using a new outer casing o-ring (115-1) apply a light film of lubricant such as Dow Corning #4 or similar to the o-ring and place it in the lower o-ring groove in the outer casing (007). Ensure that it is seated smoothly and evenly in the groove.
- (6) Place the outer casing (007) over the entire assembly and install into the bottom casing (006). The outer casing may not seem to seat at this time, but the tie rods will be tightened in a later step, which will complete the seating of the outer casing (007).
- (7) Using a new outer casing o-ring (115/1), apply a light film of lubricant such as Dow Corning #4, or similar, to the o-ring and place it into the o-ring groove on the upper pump body (007) ensuring that it is seated smoothly into the o-ring groove.



Instructions and Operation

- (8) Ensure that the rotating mechanical seal assembly is installed as detailed in Section 7A, steps 11 and 12.
- (9) Carefully place the motor bracket (162) over the pump shaft and the tie rods and onto the outer casing.
- (10) Replace the tie rod washers and nuts onto the tie rods finger tight.
- (11) Commence staggered tightening of the tie rod nuts to ensure even distribution of pressure and proper seating of the motor bracket onto the pump casing (007). Tighten all nuts to fit snugly. See torque specifications, page 21.
- (12) Slide the stationary seal seat assembly (111-3) over the shaft and into place. Secure the assembly by installing and tightening the 4 socket head screws (120-3).
- (13) Re-install the shaft pin (131-1).
- (14) Re-install the coupling by sliding one half and then the other over the shaft pin. Install the bolts in the lower half of the coupling tightening only until the shaft pin is secured in place and the coupling will not fall down the shaft. Final tightening of the coupling bolts will occur upon motor installation.
- (15) For reinstallation of the motor, see Section 5A.

7C – Replacing the Mechanical Seal

EVMU3 13- EVMU 3 18	EVMU 32 2-2 – EVMU32 3-2
EVMU5 7 – EVMU 5 16	EVMU 45 1-1 – EVMU 45 1
EVMU10 4 – EVMU 1016	EVMU 64 1-1
EVMU18 3 – EVMU 18 11	

- (1) For instructions on removing the motor from the pump see section 6B.
- (2) Remove the coupling guards from each side of the pump motor support.
- (3) Remove the two socket head bolts that hold the shaft coupling together. Remove the front half of the shaft coupling exposing the shaft pin.
- (4) Using pliers, carefully grasp the shaft pin (131-1) and remove it from the coupling and pump shaft. This will release the pump shaft from the fixed half of the coupling assembly.
- (5) Remove the motor adapter assembly (051) that houses the upper bearing and the fixed portion of the coupling assembly. Insert two screwdrivers or small pry bars into the groove between the motor adapter (051) and the motor bracket (162) to separate them. Take care as not to damage or crack these parts.
- (6) Remove the four small socket head bolts that secure the stationary seal seat (120-3). After removing these bolts, remove the stationary seal assembly (111-3). Slide the stationary seal seat over the pump shaft to remove.

Note: EVMU models 32, 45 and 64 listed in section 7C are equipped with a cartridge type mechanical seal. You will be removing both the stationary and rotating pieces of the mechanical seal in this step. After removal of the seal go to step 19.



Instructions and Operation

- (7) Remove the tie rod nuts and washers. The motor bracket support (162) can now be removed.
- (8) Remove the old rotating seal assembly by lifting vertically off the pump shaft. The rotating assembly is rubber boot mounted.
Do not remove the shaft sleeve that is below the rotating assembly.
- (9) Remove the outer casing (007), remove the o-rings (115-1) from the top and bottom of the outer casing.
- (10) Slide the new rotating seal assembly onto the shaft taking care not to scratch or touch the seal face. Apply a small amount of non-petroleum based lubricant on the inside of the rotating assembly. (i.e., dish soap, or Dow Corning #4 lubricant or similar) If touching the seal face is necessary, gently wipe with a clean soft tissue.
- (11) Push the rotating seal assembly into place on the shaft, seating the rubber boot snugly.
- (12) Carefully, press the stationary seal assembly into the stationary seal housing (111-3). Be sure that the stationary seal is evenly seated.
- (13) Using a new outer casing o-ring (115-1) apply a light film of lubricant such as Dow Corning #4 or similar to the o-ring and place it in the lower o-ring groove in the outer casing (007). Ensure that it is seated smoothly and evenly in the groove.
- (14) Place the outer casing (007) over the entire assembly and install into the bottom casing (006). The outer casing may not seem to seat at this time, but the tie rods will be tightened in a later step, which will complete the seating of the outer casing (007).
- (15) Using a new outer casing o-ring (115/1), apply a light film of lubricant such as Dow Corning #4, or similar, to the o-ring and place it into the upper o-ring groove on the outer casing (007) ensuring that it is seated smoothly into the o-ring groove.
- (16) Carefully place the motor bracket (162) over the pump shaft and the tie rods and onto the outer casing.
- (17) Replace the tie rod washers and nuts onto the tie rods finger tight.
- (18) Commence staggered tightening of the tie rod nuts to ensure even distribution of pressure and proper seating of the motor bracket onto the pump casing (007). Tighten all nuts to fit snugly. See torque specifications, page 21.
- (19) Slide the stationary seal seat assembly (111-3) (or cartridge seal assembly if equipped) over the shaft and into place. Secure the assembly by installing and tightening the 4 socket head screws (120-3).

Note: EVMU models 32, 45 and 64 After securing the seal in place as instructed above, tighten the three setscrews in the locking collar.



Instructions and Operation

- (20) With the hole in the end of the pump shaft visible through the side opening of the motor bracket (162), reinstall the upper motor adapter (051) and bearing assembly into the motor bracket. Be sure that the motor mounting holes are aligned correctly and the hole in the end of the pump shaft is lined-up with the hole in the back of the motor coupling behind the pump shaft.
- (21) Next, reinstall the shaft pin (131-1) into the hole in the pump shaft making sure that it seats inside the hole in the back of the coupling also. Reattach the other coupling half and tighten the two coupling bolts with an allen wrench. See torque specifications, page 21.
- (22) Refer to Section 5B for motor installation instructions.

7D – Replacing the Mechanical Seal and Hydraulic Assembly

EVMU3 13- EVMU 3 18	EVMU 32 2-2 – EVMU32 3-2
EVMU5 7 – EVMU 5 16	EVMU 45 1-1 – EVMU 45 1
EVMU10 4 – EVMU 1016	EVMU 64 1-1
EVMU18 3 – EVMU 18 11	

- (1) Remove the old mechanical seal assembly and the outer casing as detailed in Section 7C.
- (2) Remove the old hydraulic assembly.
- (3) Ensure that the proper replacement hydraulic (stack) assembly has been selected and provided for the pump.
- (4) Lift the replacement hydraulic (stack) assembly and place it onto the bottom casing (006) ensuring that it is seated properly. The bottom impeller should slip into the casing wear ring.
- (5) Using a new outer casing o-ring (115-1) apply a light film of lubricant such as Dow corning #4 or similar to the o-ring and place it in the lower o-ring groove in the outer casing (007). Ensure that it is seated smoothly and evenly in the groove.
- (6) Place the outer casing (007) over the entire assembly and install it into the bottom casing (006). The outer casing may not seem to seat at this time, but the tie rods will be tightened in a later step, which will complete the seating of the outer casing (007).
- (7) Using a new outer casing o-ring (115/1), apply a light film of lubricant such as Dow Corning #4, or similar, to the o-ring and place it into the upper o-ring groove on the outer casing (007) ensuring that it is seated smoothly into the o-ring groove.
- (8) Ensure that the rotating mechanical seal assembly is installed as detailed in Section 7C, steps 10 and 11.

Note: EVMU models 32, 45 and 64 listed in section 7D are equipped with a cartridge type mechanical seal; this step can be skipped. The cartridge seal will be installed at step 12. Proceed to step 9.



Instructions and Operation

- (9) Carefully place the motor bracket (162) over the pump shaft and the tie rods and onto the outer casing.
- (10) Replace the tie rod washers and nuts onto the tie rods finger tight.
- (11) Commence staggered tightening of the tie rod nuts to ensure even distribution of pressure and proper seating of the motor bracket (162) onto the pump casing (007). Tighten all nuts to fit snugly. See torque specifications, page 21.
- (12) Press the stationary seal and o-ring into the seal seat. Slide the stationary seal seat assembly (111-3) (or cartridge seal assembly, if equipped) over the shaft and into place. Secure the assembly by installing and tightening the 4 socket head screws (120-3).

Note: EVMU models 32, 45 and 64 After securing the seal in place as instructed above, tighten the three setscrews in the locking collar.

- (13) With the hole in the end of the pump shaft visible through the side opening of the motor bracket (162), reinstall the motor adapter (051) and bearing assembly into the motor bracket. Be sure that the motor mounting holes are aligned correctly and the hole in the end of the pump shaft is lined-up with the hole in the back of the motor coupling behind the pump shaft.
- (14) Next, reinstall the locking pin into the hole in the pump shaft making sure that it seats inside the hole in the back of the coupling also. Reattach the other coupling half and tighten the two coupling bolts with an allen wrench. See torque specifications, page 21.
- (15) For reinstallation of the motor, see Section 5B.

7E – Replacing the Mechanical Seal

EVMU 32 3 – EVMU32 10-1
EVMU 45 2-1 – EVMU 45 7-2
EVMU 64 1 – EVMU 64 4

- (1) Remove the coupling guard on each side of the pump's cast iron motor bracket (162).
- (2) Remove the two socket head bolts that hold the two halves of the lower spacer coupling together (120-6). Remove the front half of the shaft coupling which will then expose the shaft pin (131-1).
- (3) Next, loosen but do not remove the four hex head bolts (120-5) that secure the remaining half of the spacer coupling to the upper coupling and bearing assembly above. With these bolts loosened, use pliers to carefully grasp and remove the shaft pin (131-1) from the pump shaft. This will disengage the pump shaft from the coupling.
- (4) Completely remove the four hex head bolts (120-5) that were loosened in the previous step. With these bolts removed, remove the remaining half of the spacer coupling.
- (5) Remove the four retaining bolts from the stationary seal plate (120-3). Loosen the three setscrews in the locking collar above the stationary seal plate and slide the entire cartridge seal out of the pump.

Instructions and Operation

- (6) Carefully install the new cartridge seal over the pump shaft and into the top of the pump being sure that it is firmly seated. Re-install the four retaining bolts (120-3) that secure the cartridge seal to the pump and tighten the three setscrews in the locking collar.
- (7) Reinstall the spacer coupling. Thread the hex head bolts (120-5) back through the top of the spacer coupling loosely so it is supported but do not fully tighten. Be sure that the cross key is aligned with the keyway in the bearing assembly above. Spin the spacer coupling so that hole in the pump shaft is aligned with hole in the rear of the spacer coupling.
- (8) Reinstall the shaft pin (131-1) through the hole in the pump shaft making sure that it seats in the blind hole in the back of the spacer coupling. Once the locking pin has been installed and the pump shaft and spacer coupling are engaged via the locking pin, install the front half of the spacer coupling and install the two socket head bolts (120-6) that secure it.
- (9) Firmly tighten the four hex head bolts (120-5) that secure the spacer coupling to the upper coupling and bearing assembly above being sure that the drive key is positioned correctly so that these parts are properly engaged with each other.

The working length of the seal is set by completion of this step. There is no other adjustment that needs to be made to the seal.

- (10) Reattach the coupling guards to each side of the pump and then reinstall the motor to complete.
- (11) See Section 5B for motor installation.

7F – Replacing the Mechanical Seal and Hydraulic Assembly

EVMU 32 3 – EVMU32 10-1
EVMU 45 2-1 – EVMU 45 7-2
EVMU 64 1 – EVMU 64 4

- (1) Complete step 1- step 5 from section 7E.
- (2) Remove the tie rod nuts and washers. The cast iron motor stool (163) and upper bearing assembly can now be removed.
- (3) Remove the outer casing (007). Remove the o-rings (115-1) from the top and bottom of the outer casing.
- (4) Lift the replacement hydraulic assembly and place it onto the pump casing (006) ensuring that it is seated properly. The bottom impeller should slip into the casing wear ring.
- (5) Using a new outer casing o-ring (115-1) apply a light film of lubricant such as Dow corning #4 or similar to the o-ring and place it in the lower o-ring groove in the outer casing (007). Ensure that it is seated smoothly and evenly in the groove.
- (6) Place the outer casing (007) over the entire assembly and install it into the bottom casing (006). The outer casing (007) may not seem to seat at this time, but the tie rods will be tightened in a later step, which will complete the seating of the outer casing (007).
- (7) Using a new outer casing o-ring (115/1), apply a light film of lubricant such as Dow Corning #4, or similar, to the o-ring and place it into the o-ring groove on the upper pump body (007) ensuring that it is seated smoothly into the o-ring groove.



Instructions and Operation

- (8) Carefully place the motor stool (163) over the pump shaft and the tie rods and onto the outer casing.
- (9) Replace the tie rod washers and nuts onto the tie rods finger tight.
- (10) Commence staggered tightening of the tie rod nuts to ensure even distribution of pressure and proper seating of the motor bracket onto the pump casing (007). Tighten all nuts to fit snugly. See torque specifications, page 21.
- (11) Carefully install the new cartridge seal over the pump shaft and into the top of the pump being sure that it is firmly seated. Re-install the four retaining bolts (120-3) that secure the cartridge seal to the pump and tighten the three setscrews in the locking collar.
- (12) Reinstall the spacer coupling. Thread the hex head bolts (120-5) back through the top of the spacer coupling loosely so it is supported but do not fully tighten. Be sure that the cross key is aligned with the keyway in the bearing assembly above. Spin the spacer coupling so that hole in the pump shaft is aligned with hole in the rear of the spacer coupling.
- (13) Reinstall the shaft pin (131-1) through the hole in the pump shaft making sure that it seats in the blind hole in the back of the spacer coupling. Once the shaft pin has been installed and the pump shaft and spacer coupling are engaged via the shaft pin, install the front half of the spacer coupling and install the two socket head bolts (120-6) that secure it.
- (14) Firmly tighten the four hex head bolts (120-5) that secure the entire spacer coupling to the upper coupling and bearing assembly above being sure that the drive key is positioned correctly so that these parts are properly engaged with each other.

The working length of the seal is set by completion of this step. There is no other adjustment that needs to be made to the seal.

- (15) Reattach the coupling guards to each side of the pump and then reinstall the motor to complete.
- (16) Refer to section 5B for motor installation instructions.

Instructions and Operation

Torque Specifications

Tie Rods

Model	Thread Size		
EVMU 3 EVMU5	M10	10 Ft lbs	13 N-m
EVMU10 EVMU18	M12	19 Ft lbs	25 N-m
EVMUG32 EVMUG45 EVMUG64	M16	45 Ft lbs	61 N-m

Coupling Bolts

Model	<i>Drawing Reference</i>			
	120-5 Bolt Size		120-6 Bolt Size	
EVMU 3 EVMU5	M6	6 Ft lbs 8.5 N-m	M6	6 Ft lbs 8.5 N-m
EVMU10 2- EVMU 10 3	M6	6 Ft lbs 8.5 N-m	M6	6 Ft lbs 8.5 N-m
EVMU10 4- EVMU 10 12			M8	15Ft lbs 20 N-m
EVMU10 13- EVMU 10 16			M10	30 Ft lbs 40 N-m
EVMU 18 2	M6	6 Ft lbs 8.5 N-m	M6	6 Ft lbs 8.5 N-m
EVMU 18 3 - EVMU 18 5			M8	15Ft lbs 20 N-m
EVMU 18 6 - EVMU 18 11			M10	30 Ft lbs 40 N-m
EVMU 32 1	M6	6 Ft lbs 8.5 N-m	M6	6 Ft lbs 8.5 N-m
EVMU32 2-2 - EVMU32 3-2			M8	15Ft lbs 20 N-m
EVMU 32 3- EVMU 32 10-1	M10	30 Ft lbs 40 N-m	M12	50 Ft lbs 68 N-m
EVMU 45 1-1 - EVMU 45 1			M8	15Ft lbs 20 N-m
EVMU 45 2-1 - EVMU 45 7-2	M10	30 Ft lbs 40 N-m	M12	50 Ft lbs 68 N-m
EVMU 64 1-1			M8	15Ft lbs 20 N-m
EVMU 64 1-0 - EVMU 64 4-0	M10	30 Ft lbs 40 N-m	M12	50 Ft lbs 68 N-m

Instructions and Operation

Sectional View

Models EVMU(L)3 2 – EVMU(L)3 12

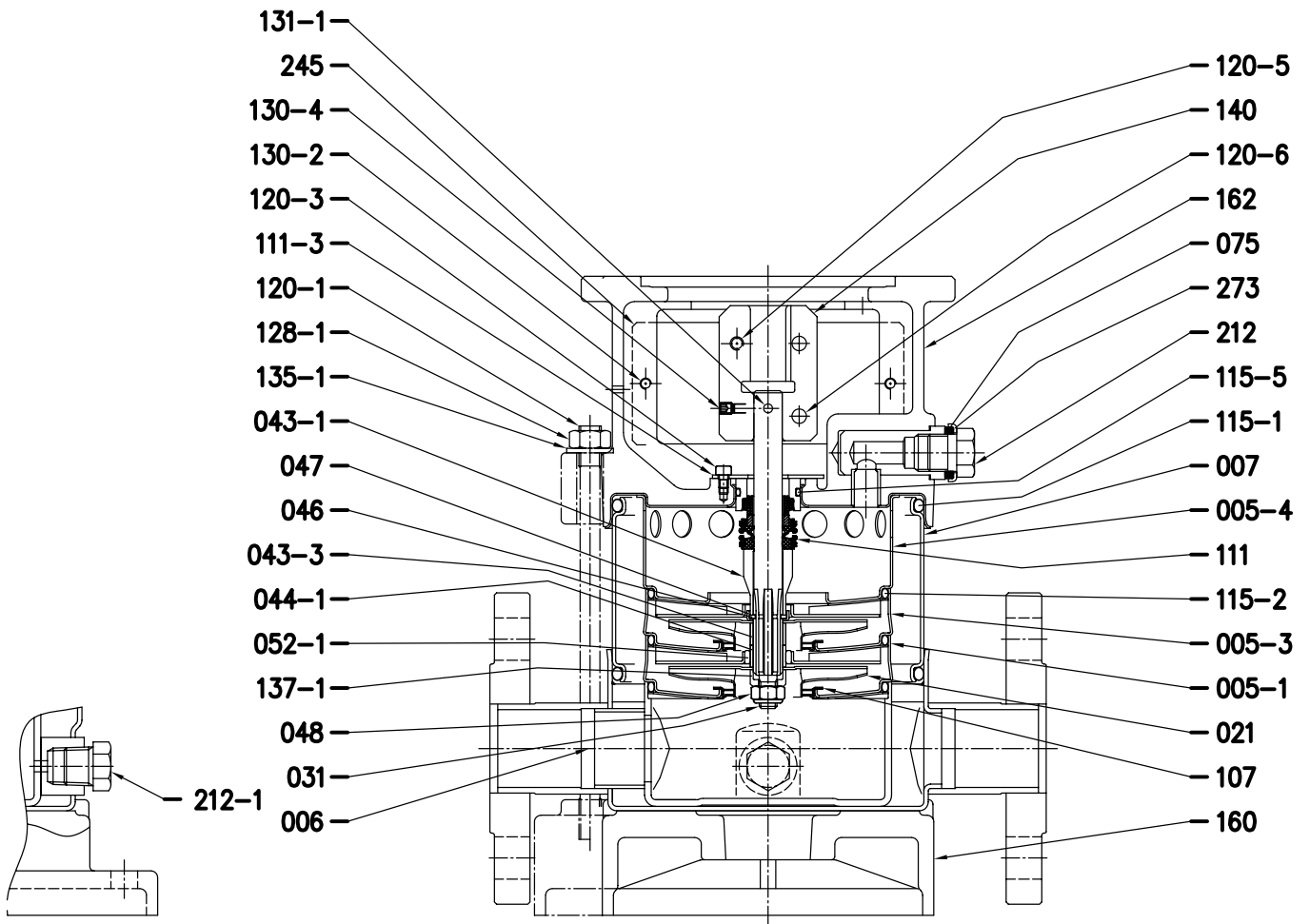

Refer to page 26 for material details.

(For reference only. See pricing for part availability.)



Instructions and Operation

Sectional View

Models EVMU(L)3 13 – EVMU(L)3 18

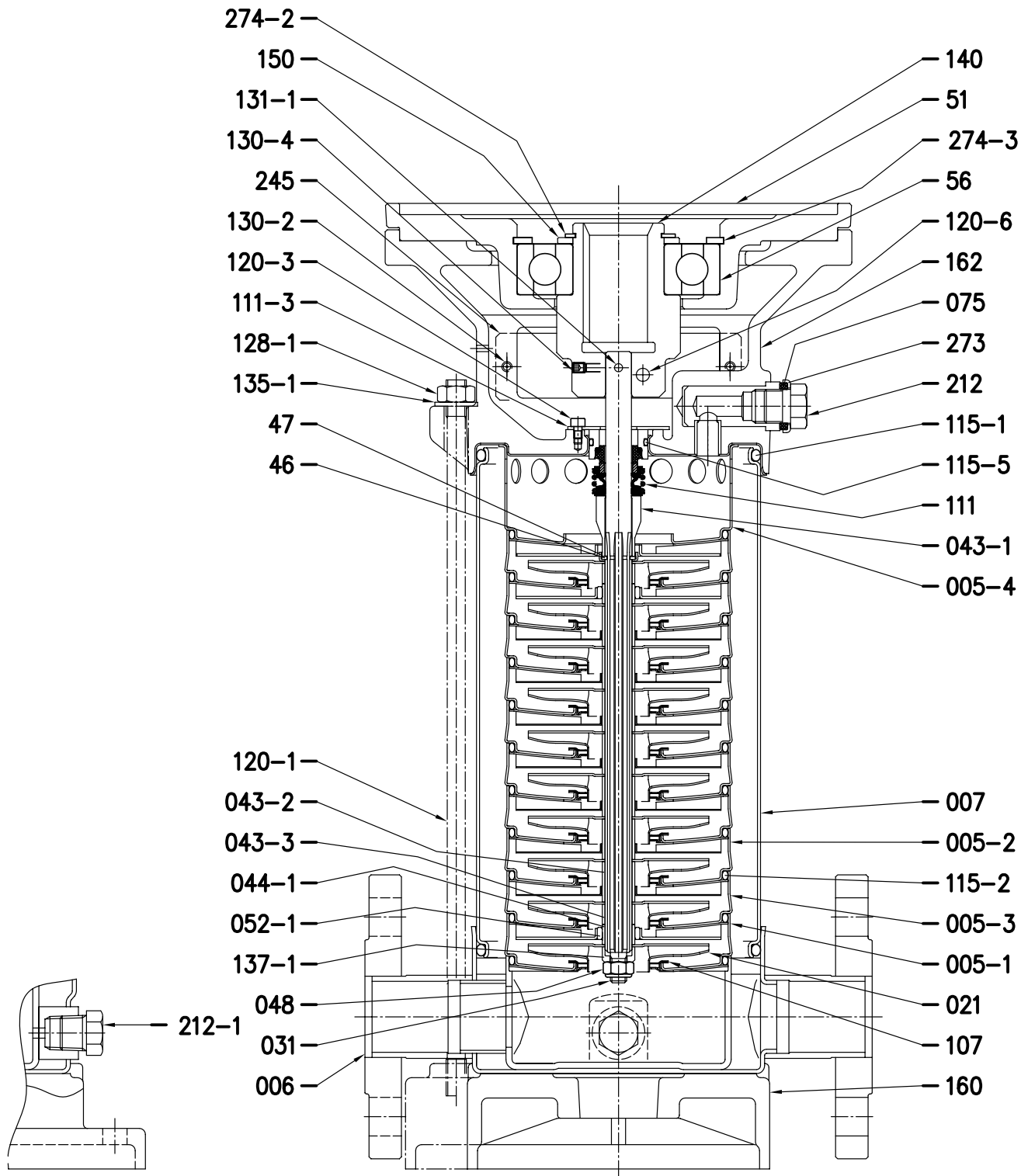

Refer to page 26 for material details.

(For reference only. See pricing for part availability.)

Instructions and Operation

Sectional View

Models EVMU(L)5 2 – EVMU(L)5 6

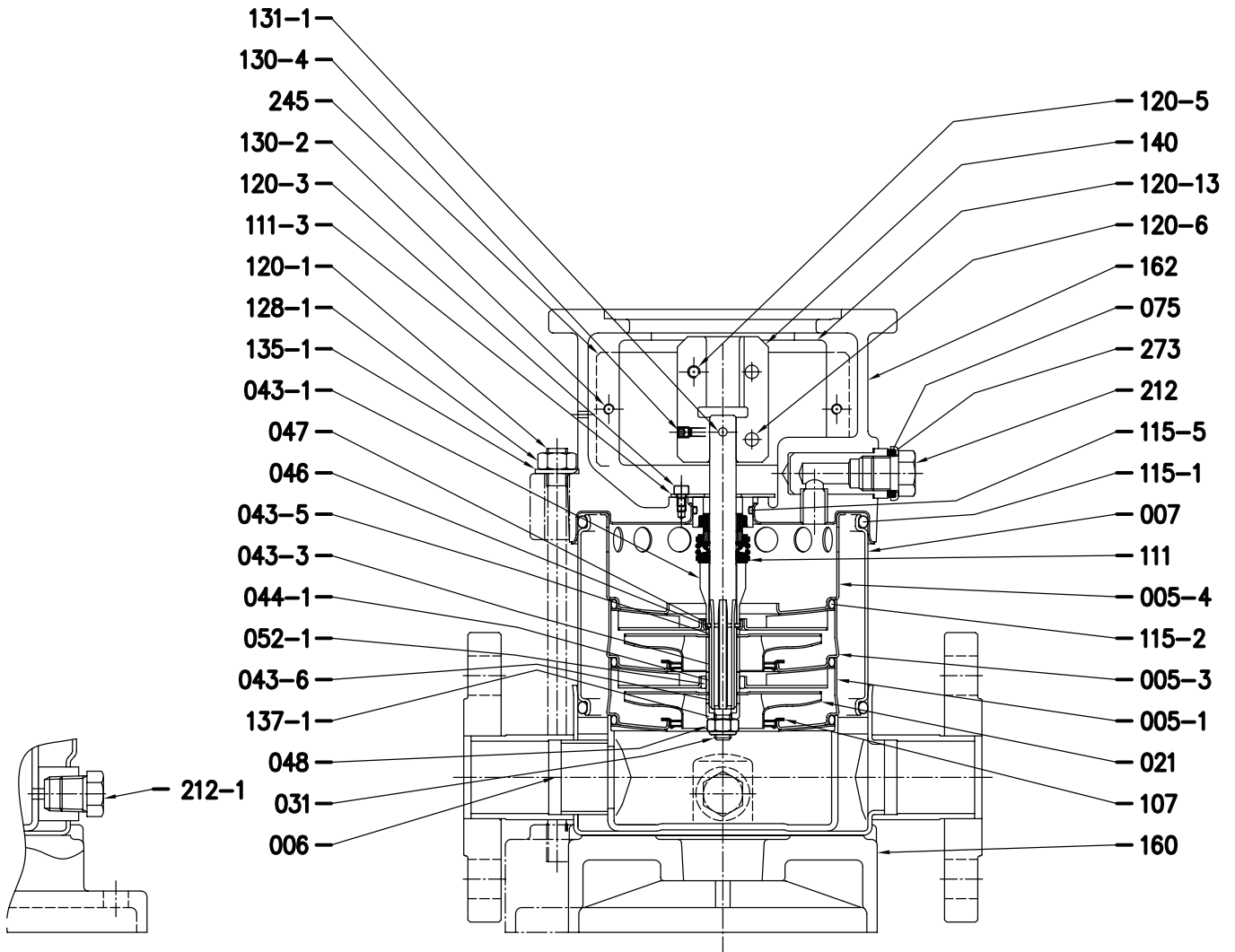

Refer to page 26 for material details.

(For reference only. See pricing for part availability.)



Instructions and Operation

Sectional View

Models EVMU(L)5 7 – EVMU(L)5 16

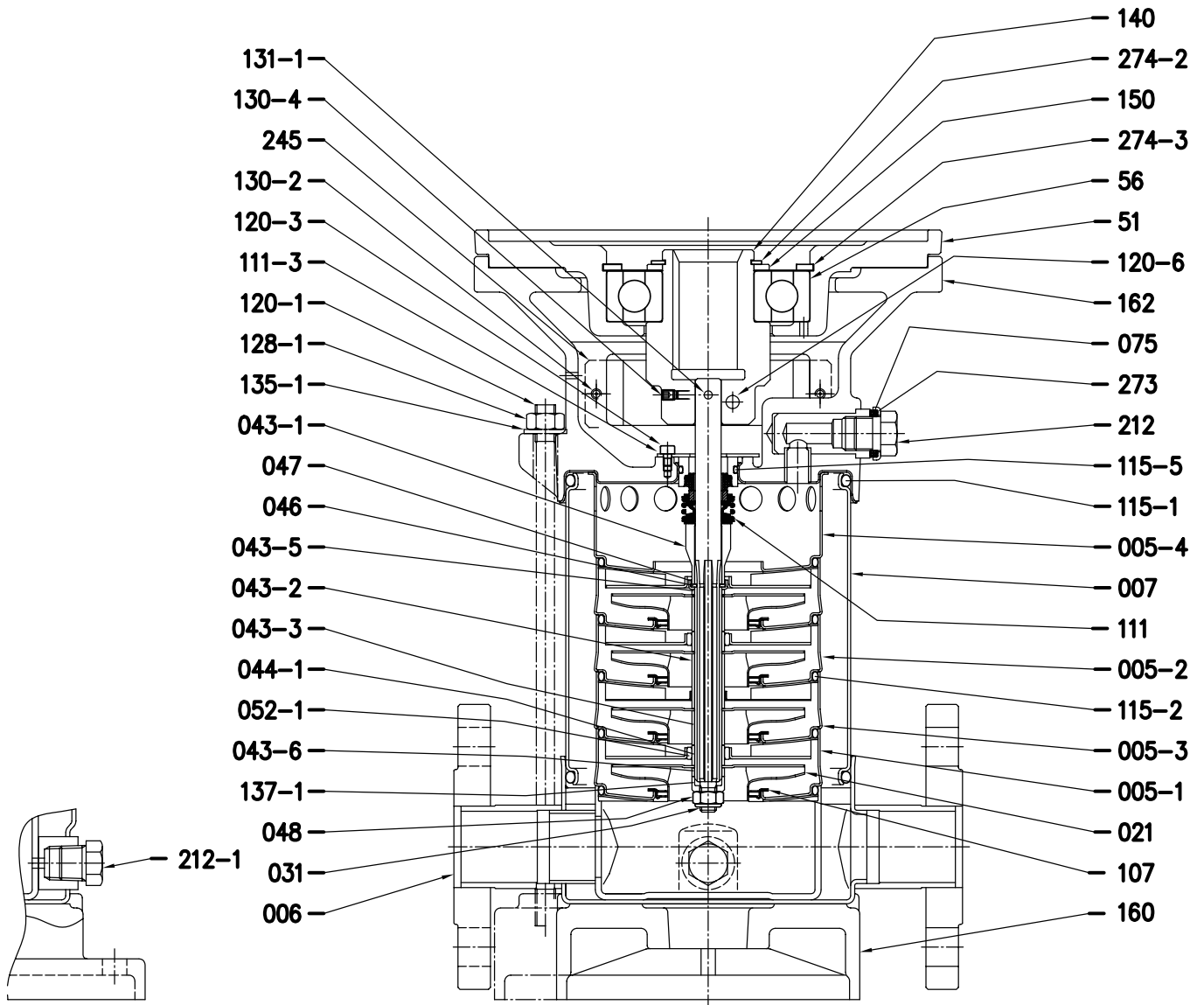

Refer to page 26 for material details.

(For reference only. See pricing for part availability.)

Instructions and Operation

Sectional View – Part reference

**Models EVMU(L)3
EVMU(L)5**

N°	Part name	Material	
		EVMU	EVMUL
005-1	Suction casing	EN 1.4301(AISI 304)	EN 1.4401 (AISI 316)
005-2	Intermediate casing	EN 1.4301(AISI 304)	EN 1.4401 (AISI 316)
005-3	Intermediate casing bearing	EN 1.4301(AISI 304)	EN 1.4401 (AISI 316)
005-4	Discharge casing	EN 1.4301(AISI 304)	EN 1.4401 (AISI 316)
006	Bottom casing	EN 1.4301(AISI 304)	EN 1.4401 (AISI 316)
007	Outer casing	EN 1.4301(AISI 304)	EN 1.4401 (AISI 316)
021	Impeller	EN 1.4301(AISI 304)	EN 1.4401 (AISI 316)
031	Shaft	EN 1.4401 (AISI 316)	
043-1	Shaft sleeve (mechanical seal)	EN 1.4301(AISI 304)	EN 1.4401 (AISI 316)
043-2	Shaft sleeve (intermediate)	EN 1.4301(AISI 304)	EN 1.4401 (AISI 316)
043-3	Shaft sleeve (bearing)	EN 1.4301(AISI 304)	EN 1.4401 (AISI 316)
043-5	Shaft sleeve (last stage)	EN 1.4301(AISI 304)	EN 1.4401 (AISI 316)
043-6	Shaft sleeve (adjustment)	EN 1.4301(AISI 304)	EN 1.4401 (AISI 316)
044-1	Shaft sleeve bearing	Tungsten carbide	
046	Split ring (mechanical seal)	EN 1.4301(AISI 304)	EN 1.4401 (AISI 316)
047	Ring holder	EN 1.4301(AISI 304)	EN 1.4401 (AISI 316)
048	Impeller nut	A2-70 UNI 7323 with inox insert	A4-70 UNI 7323 with inox insert
051	Motor adapter	Cast iron EN-GJL-200-EN 1561	
052-1	Bearing	Tungsten carbide	
056	Ball bearing		
070-1	Ring for bearing	EN 1.4301(AISI 304)	
075	O-ring (plug)	FPM	
075-1	O-ring (plug)	FPM	
107	Liner ring	PTFE/EN 1.4401 (AISI 316)	
111	Mechanical seal	Silicon carbide/Carbon/FPM	
111-3	Mechanical seal seat	EN 1.4301(AISI 304)	EN 1.4401 (AISI 316)
115-1	O-ring (outer casing)	FPM	
115-2	O-ring (intermediate casing)	FPM	
115-5	O-ring	FPM	

(For reference only. See pricing for part availability.)



Instructions and Operation

Sectional View – Part reference

**Models EVMU(L)3
EVMU(L)5**

N°	Part name	Material	
		EVMU	EVMUL
120-1	Tie rod	Zincate steel	
120-3	Screw	A2-70 UNI 7323	
120-5	Screw for coupling	Zincate steel 8.8 strenght class ISO 898/1	
120-6	Screw for coupling	Zincate steel 8.8 strenght class ISO 898/1	
128-1	Nut for tie rod	Zincate steel	
130-2	Screw for coupling guard	A2-70 UNI 7323	
130-4	Set-screw	Carbon steel	
131-1	Pin for shaft	Carbon steel	
135-1	Washer	Zincate steel	
135-4	Washer (bearing)	Carbon steel	
137-1	Impeller spacer	EN 1.4301(AISI 304)	EN 1.4401 (AISI 316)
140	Coupling	Brass OT 58 UNI 5705	
150	Spacer	Carbon steel	
160	Base	Cast iron EN-GJL-200-EN 1561	
162	Motor bracket	Cast iron EN-GJL-200-EN 1561+ EN 1.4301(AISI 304)	Cast iron + EN 1.4401 (AISI 316)
169	Motor adapter	Cast iron EN-GJL-200-EN 1561	
212	Plug	EN 1.4301(AISI 304)	EN 1.4401 (AISI 316)
212-1	Plug	EN 1.4301(AISI 304)	EN 1.4401 (AISI 316)
245	Coupling guard	EN 1.4301(AISI 304)	
273	Washer (plug)	EN 1.4301(AISI 304)	EN 1.4401 (AISI 316)
273-1	Washer (plug)	EN 1.4301(AISI 304)	/
274-2	C-type snap ring (coupling)	EVMU3 13, EVMU5 7 ,8	Carbon steel TC 80
		EVMU3 15, 18, EVMU5 10 to 16	
274-3	C-type snap ring (bracket)	EVMU3 13, EVMU5 7 ,8	Carbon steel TC 80
		EVMU3 15, 18, EVMU5 10 to 16	

(For reference only. See pricing for part availability.)



Instructions and Operation

Sectional View

Models EVMU(L)10 2 – EVMU(L)10 3

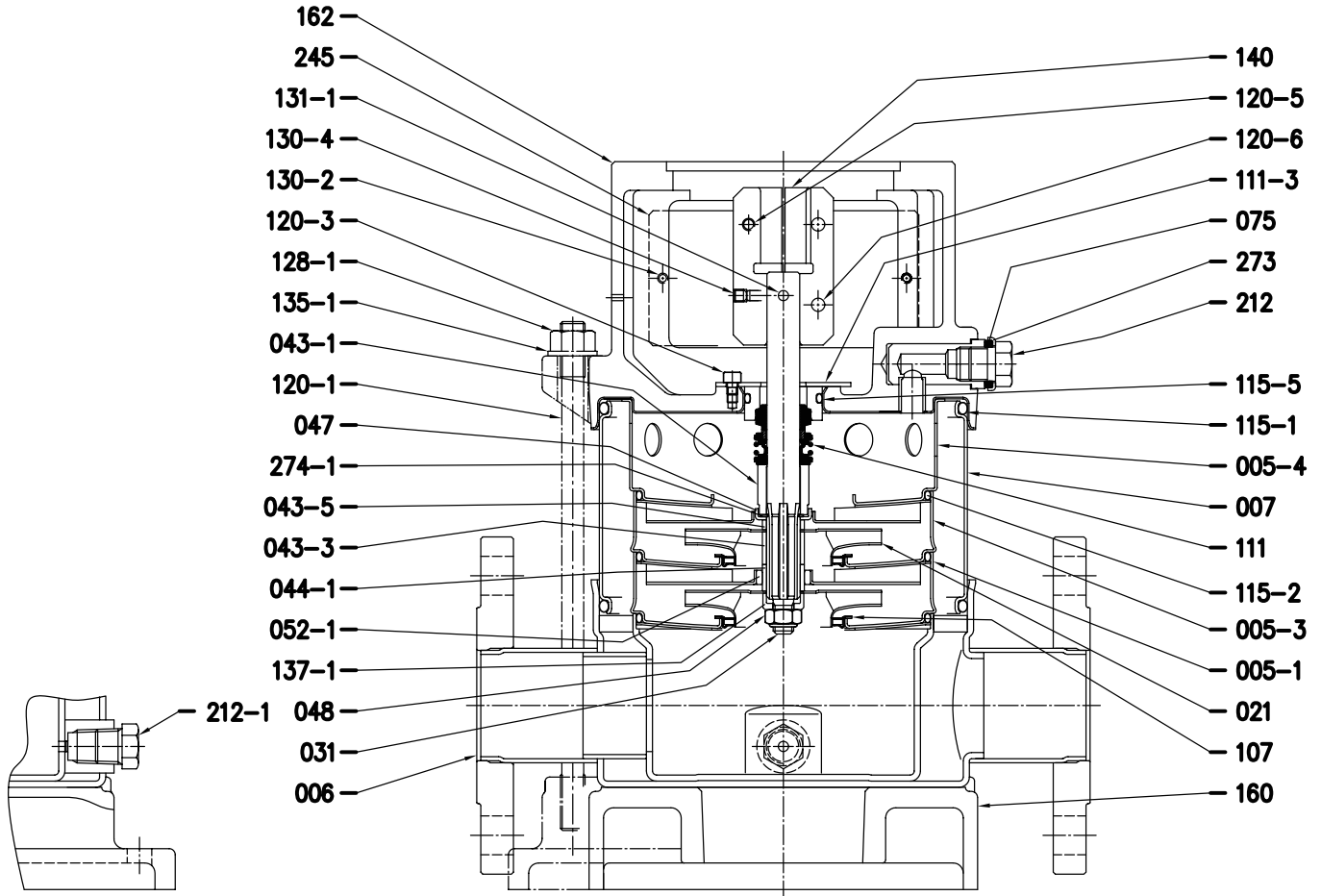

Refer to page 34 for material details.

(For reference only. See pricing for part availability.)



Instructions and Operation

Sectional View

Models EVMU(L)10 4 – EVMU(L)10 12

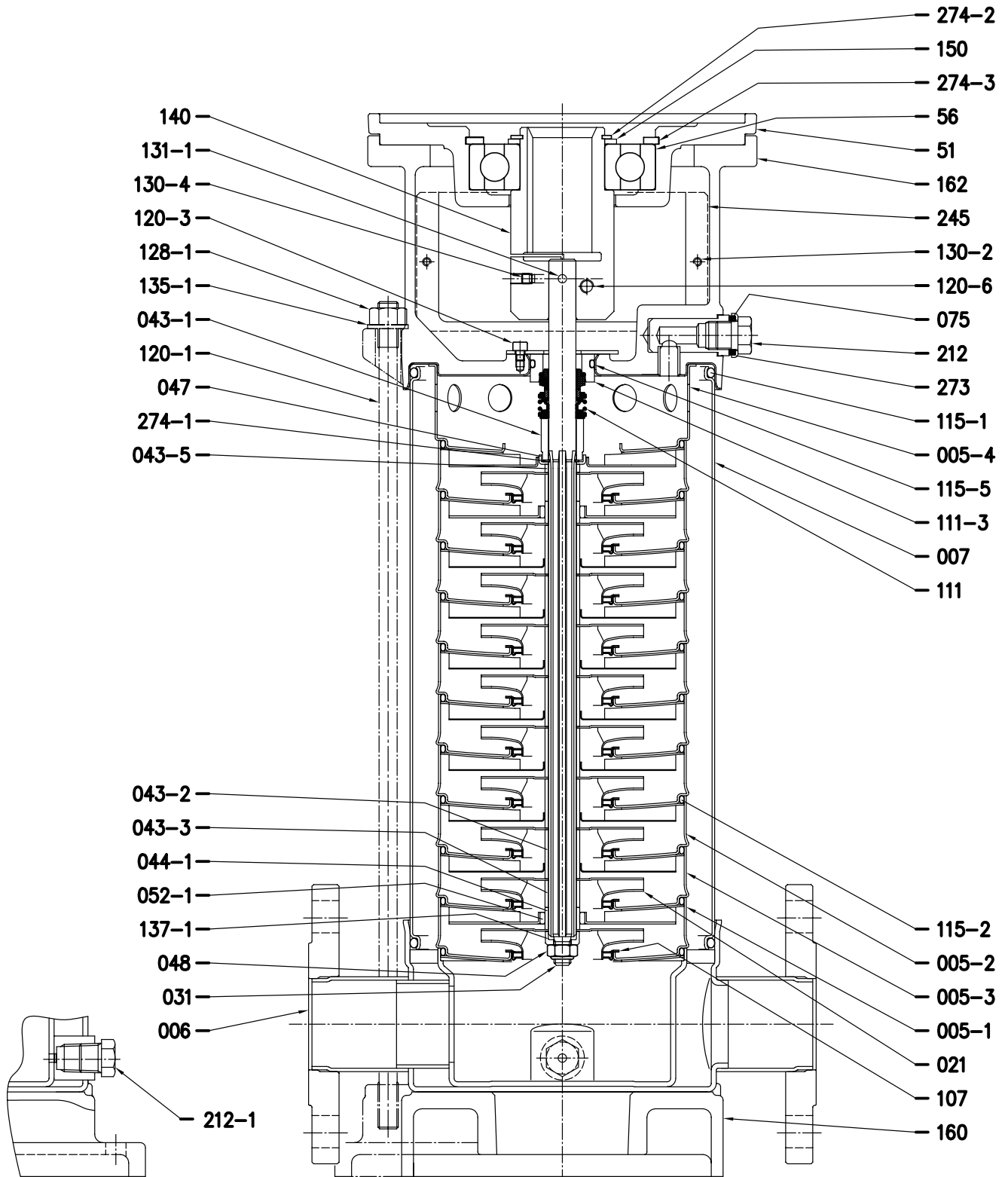

Refer to page 34 for material details.

(For reference only. See pricing for part availability.)

Instructions and Operation

Sectional View

Models EVMU(L)10 14 – EVMU(L)10 16

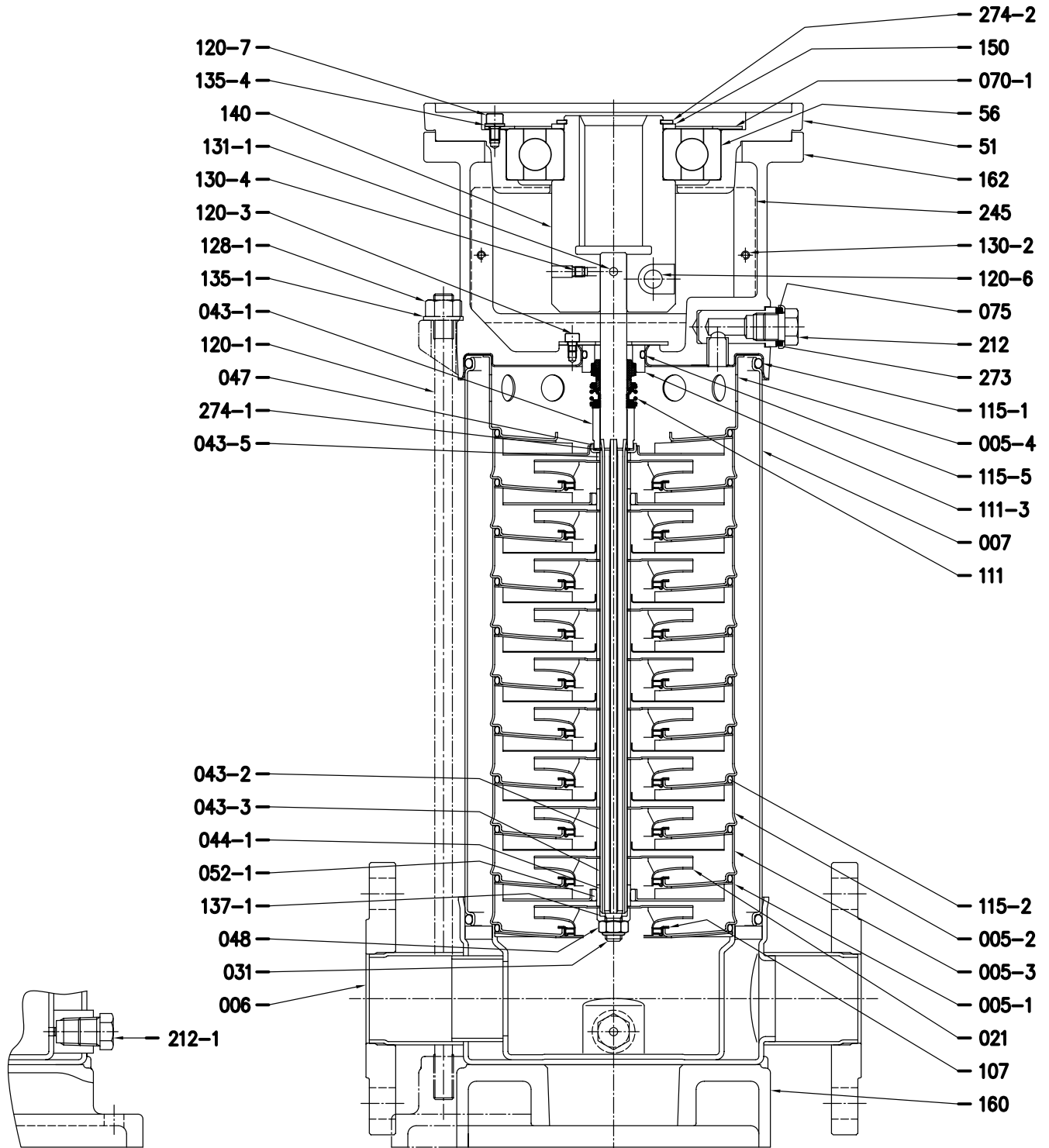

Refer to page 34 for material details.

(For reference only. See pricing for part availability.)

Instructions and Operation

Sectional View
Models EVMU(L)18 2

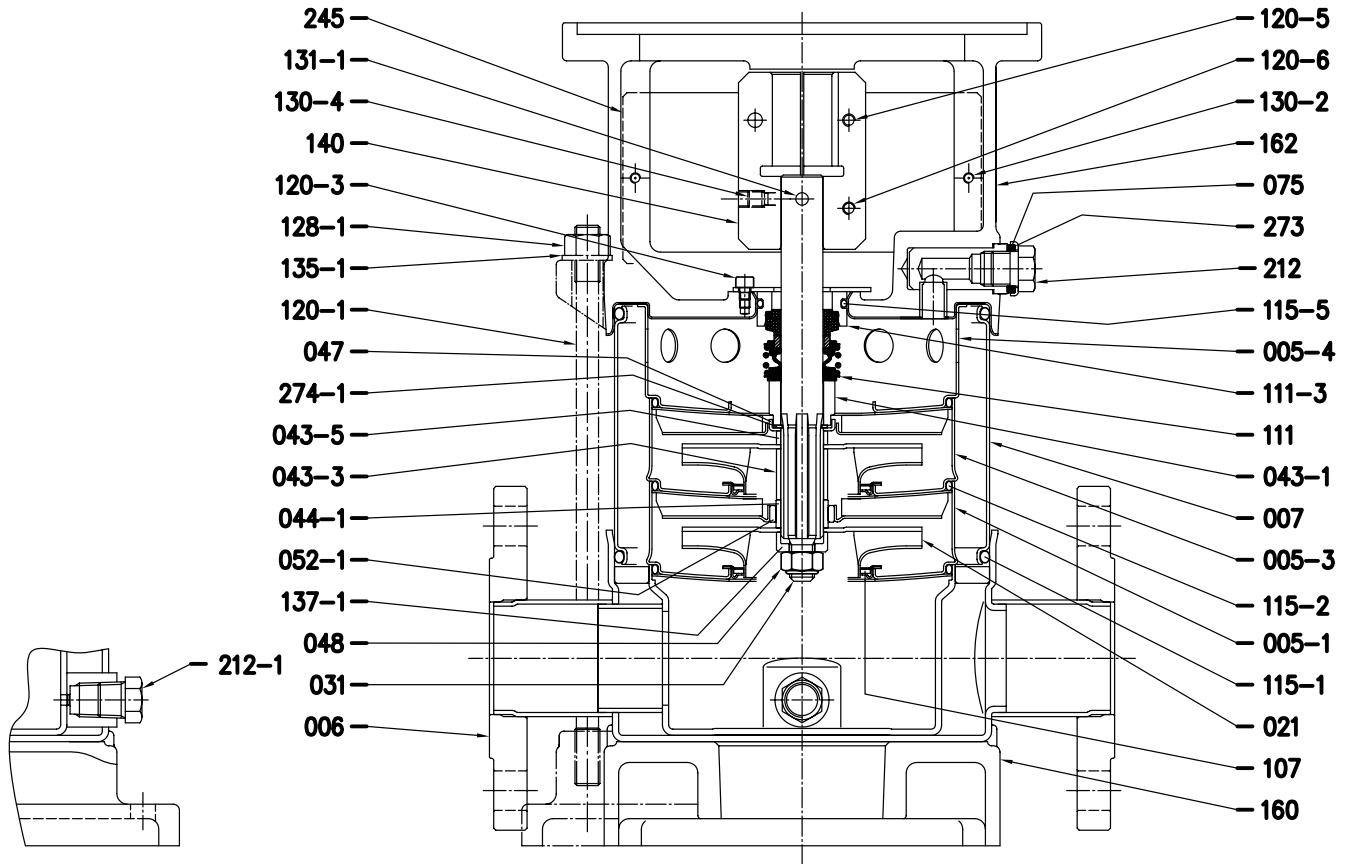

Refer to page 36 for material details.

(For reference only. See pricing for part availability.)



Instructions and Operation

Sectional View

Models EVMU(L)18 3 – EVMU(L)18 5

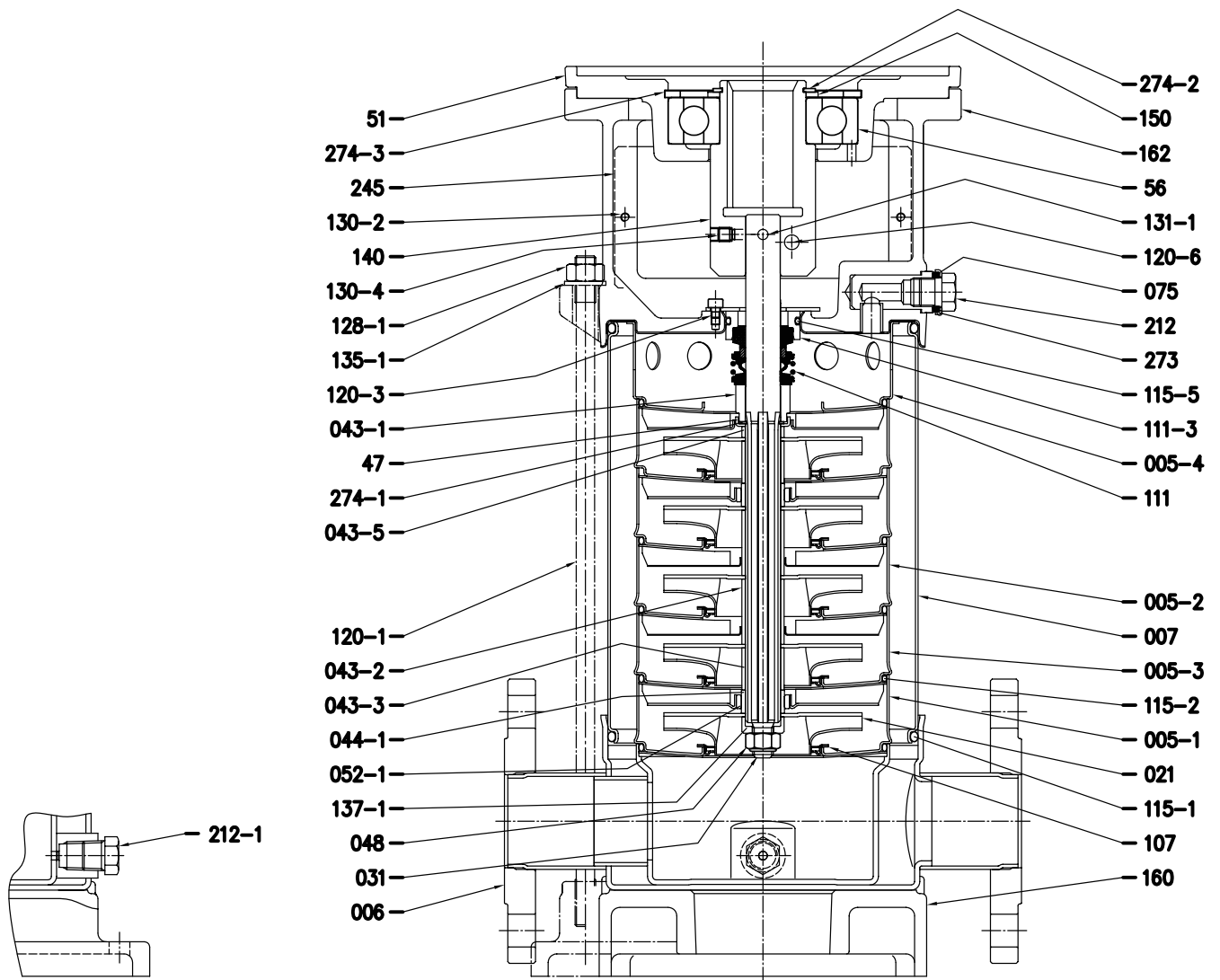

Refer to page 36 for material details.

(For reference only. See pricing for part availability.)

Instructions and Operation

Sectional View

Models EVMU(L)18 6 – EVMU(L)18 11

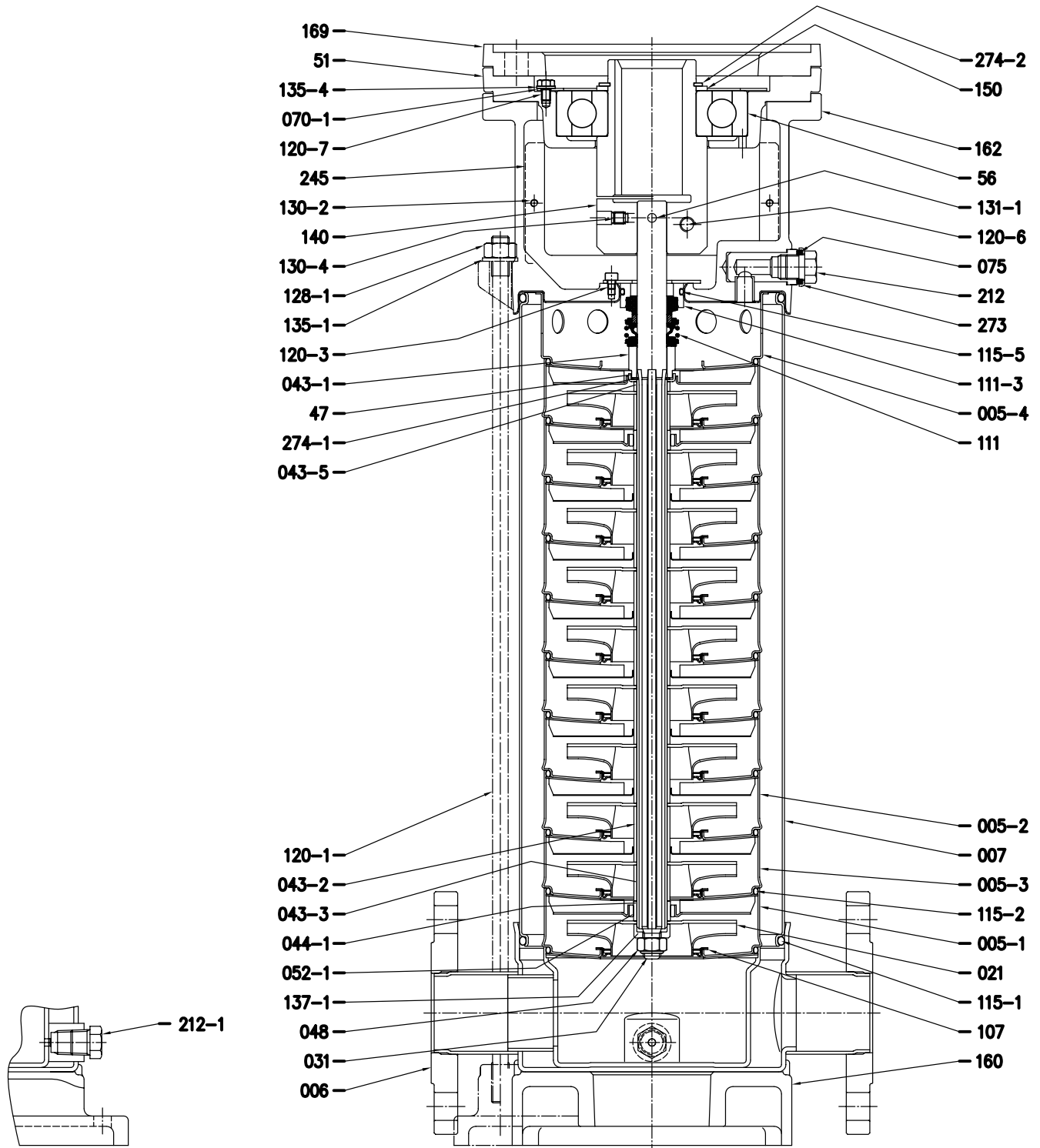

Refer to page 36 for material details.

(For reference only. See pricing for part availability.)

Instructions and Operation

Sectional View – Part reference

Model EVMU(L)10

N°	Part name	Material	
		EVMU	EVML
005-1	Suction casing	EN 1.4301(AISI 304)	EN 1.4401 (AISI 316)
005-2	Intermediate casing	EN 1.4301(AISI 304)	EN 1.4401 (AISI 316)
005-3	Intermediate casing bearing	EN 1.4301(AISI 304)	EN 1.4401 (AISI 316)
005-4	Discharge casing	EN 1.4301(AISI 304)	EN 1.4401 (AISI 316)
006	Bottom casing	EN 1.4301(AISI 304)	EN 1.4401 (AISI 316)
007	Outer casing	EN 1.4301(AISI 304)	EN 1.4401 (AISI 316)
021	Impeller	EN 1.4301(AISI 304)	EN 1.4401 (AISI 316)
031	Shaft	EN 1.4401 (AISI 316)	
043-1	Shaft sleeve (mechanical seal)	EN 1.4301(AISI 304)	EN 1.4401 (AISI 316)
043-2	Shaft sleeve (intermediate)	EN 1.4301(AISI 304)	EN 1.4401 (AISI 316)
043-3	Shaft sleeve (bearing)	EN 1.4301(AISI 304)	EN 1.4401 (AISI 316)
043-5	Shaft sleeve (last stage)	EN 1.4301(AISI 304)	EN 1.4401 (AISI 316)
043-6	Shaft sleeve (adjustment)	EN 1.4301(AISI 304)	EN 1.4401 (AISI 316)
044-1	Shaft sleeve bearing	Tungsten carbide	
046	Split ring (mechanical seal)	EN 1.4301(AISI 304)	EN 1.4401 (AISI 316)
047	Ring holder	EN 1.4301(AISI 304)	EN 1.4401 (AISI 316)
048	Impeller nut	A2-70 UNI 7323 with inox insert	A4-70 UNI 7323 with inox insert
051	Motor adapter	Cast iron EN-GJL-200-EN 1561	
052-1	Bearing	Tungsten carbide	
056	Ball bearing	See table pag. 500	
070-1	Ring for bearing	EN 1.4301(AISI 304)	
075	O-ring (plug)	FPM	
075-1	O-ring (plug)	FPM	/
107	Liner ring	PTFE/EN 1.4401 (AISI 316)	
111	Mechanical seal	Silicon carbide/Carbon/FPM	
111-3	Mechanical seal seat	EN 1.4301(AISI 304)	EN 1.4401 (AISI 316)
115-1	O-ring (outer casing)	FPM	
115-2	O-ring (intermediate casing)	FPM	
115-5	O-ring	FPM	

(For reference only. See pricing for part availability.)



Instructions and Operation

Sectional View – Part reference

Model EVMU(L)10

N°	Part name	Material	
		EVMU	EVML
120-1	Tie rod	Zincate steel	
120-3	Screw	A2-70 UNI 7323	
120-5	Screw for coupling	Zincate steel 8.8 strenght class ISO 898/1	
120-6	Screw for coupling	EVMU10 2, EVMU10 3	
		EVMU10 4 to12	
		EVMU10 14 to16	
120-7	Screw (bearing)	Zincate steel 8.8 strenght class ISO 898/1	
128-1	Nut for tie rod	Zincate steel	
130-2	Screw for coupling guard	A2-70 UNI 7323	
130-4	Set-screw	Carbon steel	
131-1	Pin for shaft	Carbon steel	
135-1	Washer	Zincate steel	
135-4	Washer (bearing)	Carbon steel	
137-1	Impeller spacer	EN 1.4301(AISI 304)	EN 1.4401 (AISI 316)
140	Coupling	Brass OT 58 UNI 5705	
150	Spacer	Carbon steel	
160	Base	/	Cast iron EN-GJL-200-EN 1561
162	Motor bracket	Cast iron EN-GJL-200-EN 1561+ EN 1.4301(AISI 304)	Cast iron + EN 1.4401 (AISI 316)
169	Motor adapter	Cast iron EN-GJL-200-EN 1561	
212	Plug	EN 1.4301(AISI 304)	EN 1.4401 (AISI 316)
212-1	Plug	EN 1.4301(AISI 304)	EN 1.4401 (AISI 316)
245	Coupling guard	EN 1.4301(AISI 304)	
273	Washer (plug)	EN 1.4301(AISI 304)	EN 1.4401 (AISI 316)
273-1	Washer (plug)	EN 1.4301(AISI 304)	/
274-1	C-type snap ring (coupling)	EN 1.4301(AISI 304)	EN 1.4401 (AISI 316)
274-2	C-type snap ring (coupling)	EVMU10 4	
		EVMU10 5 to 8	
		EVMU10 10 to 12	
		EVMU10 14 to16	
274-3	C-type snap ring (bracket)	EVMU10 4	
		EVMU10 5 to 8	
		EVMU10 10 to 12	

(For reference only. See pricing for part availability.)

Instructions and Operation

Sectional View – Part reference

Model EVMU(L)18

N°	Part name	Material	
		EVMU	EVML
005-1	Suction casing	EN 1.4301(AISI 304)	EN 1.4401 (AISI 316)
005-2	Intermediate casing	EN 1.4301(AISI 304)	EN 1.4401 (AISI 316)
005-3	Intermediate casing bearing	EN 1.4301(AISI 304)	EN 1.4401 (AISI 316)
005-4	Discharge casing	EN 1.4301(AISI 304)	EN 1.4401 (AISI 316)
006	Bottom casing	EN 1.4301(AISI 304)	EN 1.4401 (AISI 316)
007	Outer casing	EN 1.4301(AISI 304)	EN 1.4401 (AISI 316)
021	Impeller	EN 1.4301(AISI 304)	EN 1.4401 (AISI 316)
031	Shaft	EN 1.4401 (AISI 316)	
043-1	Shaft sleeve (mechanical seal)	EN 1.4301(AISI 304)	EN 1.4401 (AISI 316)
043-2	Shaft sleeve (intermediate)	EN 1.4301(AISI 304)	EN 1.4401 (AISI 316)
043-3	Shaft sleeve (bearing)	EN 1.4301(AISI 304)	EN 1.4401 (AISI 316)
043-5	Shaft sleeve (last stage)	EN 1.4301(AISI 304)	EN 1.4401 (AISI 316)
043-6	Shaft sleeve (adjustment)	EN 1.4301(AISI 304)	EN 1.4401 (AISI 316)
044-1	Shaft sleeve bearing	Tungsten carbide	
046	Split ring (mechanical seal)	EN 1.4301(AISI 304)	EN 1.4401 (AISI 316)
047	Ring holder	EN 1.4301(AISI 304)	EN 1.4401 (AISI 316)
048	Impeller nut	A2-70 UNI 7323 with inox insert	A4-70 UNI 7323 with inox insert
051	Motor adapter	Cast iron EN-GJL-200-EN 1561	
052-1	Bearing	Tungsten carbide	
056	Ball bearing	See table pag. 500	
070-1	Ring for bearing	EN 1.4301(AISI 304)	
075	O-ring (plug)	FPM	
075-1	O-ring (plug)	FPM	/
107	Liner ring	PTFE/EN 1.4401 (AISI 316)	
111	Mechanical seal	Silicon carbide/Carbon/FPM	
111-3	Mechanical seal seat	EN 1.4301(AISI 304)	EN 1.4401 (AISI 316)
115-1	O-ring (outer casing)	FPM	
115-2	O-ring (intermediate casing)	FPM	
115-5	O-ring	FPM	

(For reference only. See pricing for part availability.)



Instructions and Operation

Sectional View – Part reference

Model EVMU(L)18

N°	Part name	Material	
		EVMU	EVML
120-1	Tie rod	Zincate steel	
120-3	Screw	A2-70 UNI 7323	
120-5	Screw for coupling	Zincate steel 8.8 strenght class ISO 898/1	
120-6	Screw for coupling	EVMU18 2	
		EVMU18 3 to 5	
		EVMU18 6 to 11	
120-7	Screw (bearing)	Zincate steel 8.8 strenght class ISO 898/1	
128-1	Nut for tie rod	Zincate steel	
130-2	Screw for coupling guard	A2-70 UNI 7323	
130-4	Set-screw	Carbon steel	
131-1	Pin for shaft	Carbon steel	
135-1	Washer	Zincate steel	
135-4	Washer (bearing)	Carbon steel	
137-1	Impeller spacer	EN 1.4301(AISI 304)	EN 1.4401 (AISI 316)
140	Coupling	Brass OT 58 UNI 5705	
150	Spacer	Carbon steel	
160	Base	Cast iron EN-GJL-200-EN 1561	
162	Motor bracket	Cast iron EN-GJL-200-EN 1561+ EN 1.4301(AISI 304)	Cast iron + EN 1.4401 (AISI 316)
169	Motor adapter	Cast iron EN-GJL-200-EN 1561	
212	Plug	EN 1.4301(AISI 304)	EN 1.4401 (AISI 316)
212-1	Plug	EN 1.4301(AISI 304)	EN 1.4401 (AISI 316)
245	Coupling guard	EN 1.4301(AISI 304)	
273	Washer (plug)	EN 1.4301(AISI 304)	EN 1.4401 (AISI 316)
273-1	Washer (plug)	EN 1.4301(AISI 304)	/
274-1	C-type snap ring (coupling)	EN 1.4301(AISI 304)	EN 1.4401 (AISI 316)
274-2	C-type snap ring (coupling)	EVMU18 3 to 4	
		EVMU18 5	
		EVMU18 6 to 10	
		EVMU18 11	
274-3	C-type snap ring (bracket)	EVMU18 3 to 4	
		EVMU18 5	

(For reference only. See pricing for part availability.)

