

Please read and save these instructions. Read Carefully before attempting to assemble, install, operate or maintain the product described. Protect yourself and others by observing all safety information. Failure to comply with instructions could result in personal injury and/or property damage in which Pumptec, Inc. will not assume any liability. Retain instructions for future reference.

SPRAYER SUB-ASSEMBLY 350U with regulator

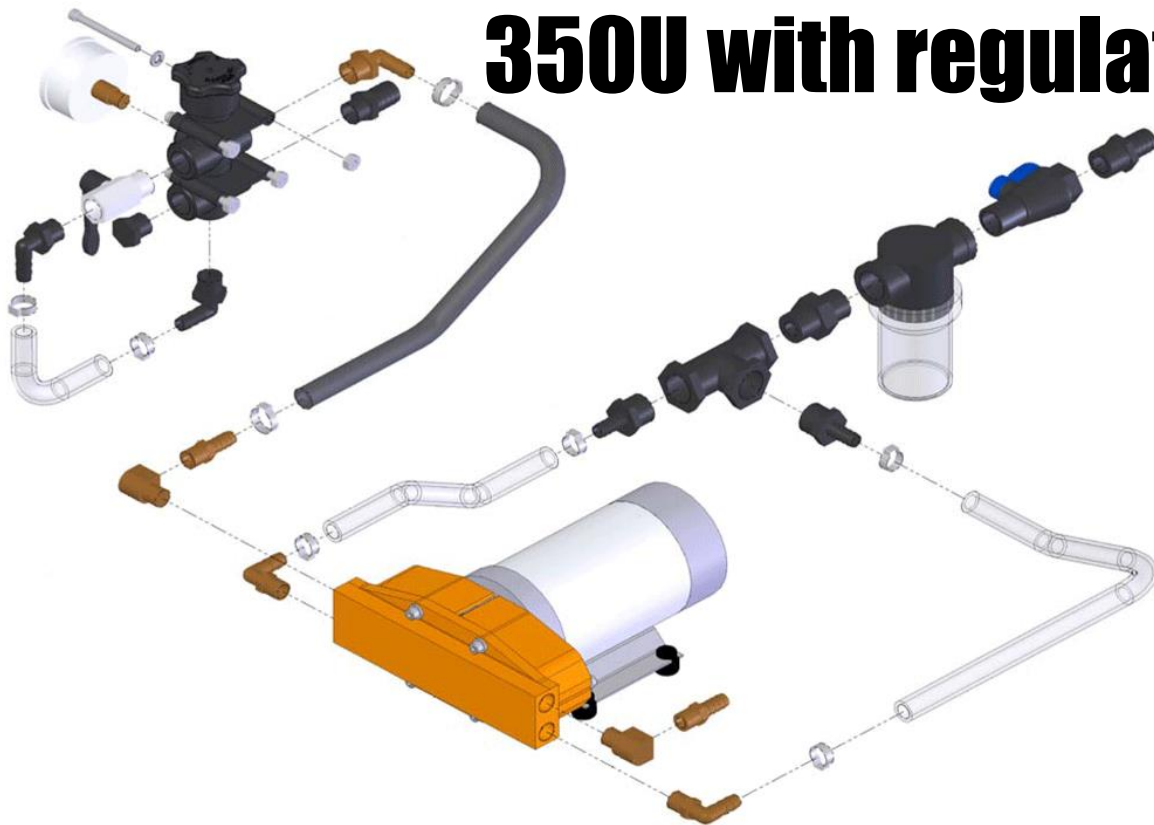

DANGER

Do not pump hazardous materials (flammable, caustic, etc.)

WARNING

Consult an automotive technician (certified to ASE T6 Truck Electrical/Electronic Systems) for final approval of wiring installation and electrical components. Improper wiring and/or use of undersized electrical components can cause equipment damage, overheating, and result in a fire.

WARNING

To reduce risk of electric shock, always disconnect pump from power source before handling or servicing.

WARNING

Pumps build up heat and pressure during operation. Bleed pressure lines and allow time for pumps to cool before handling or servicing. Only qualified personnel should install, operate, and repair pump.

Pumptec Inc. is not responsible for losses, injury, or death resulting from a failure to observe these safety precautions, misuse or abuse of pumps or equipment.

STEP 1

Bolt pump to a mounting plate.

- Choose a location where the pump is protected from rain and road spray and is less than 6 ft from your tank.

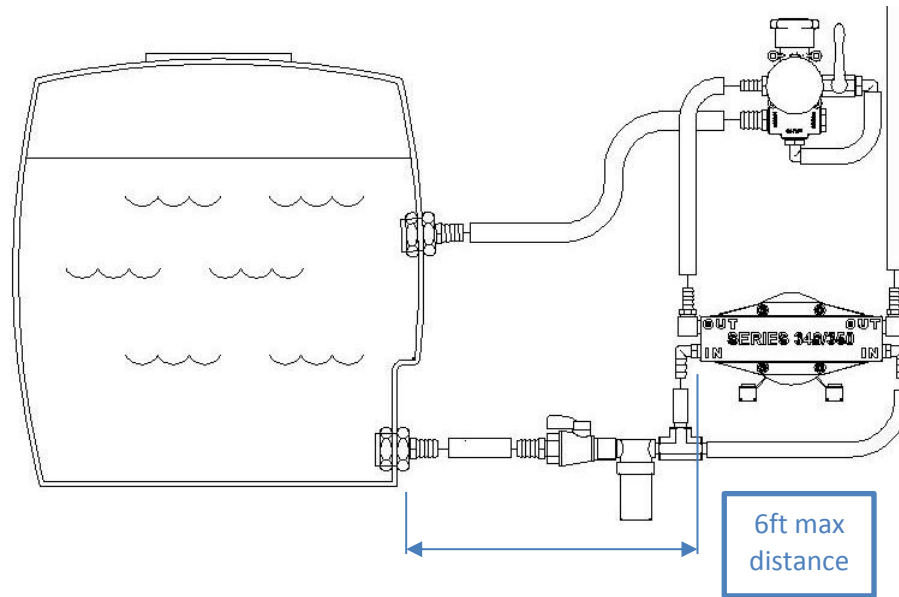

- It is best if the pump is located below the lowest water level in your tank with a downward sloping delivery hose so that the pump inlet is always flooded.
- If it is necessary to mount the pump higher, the maximum suction lift is 3 ft from the bottom of the tank.
- A foot valve is recommended for all suction-lift applications.

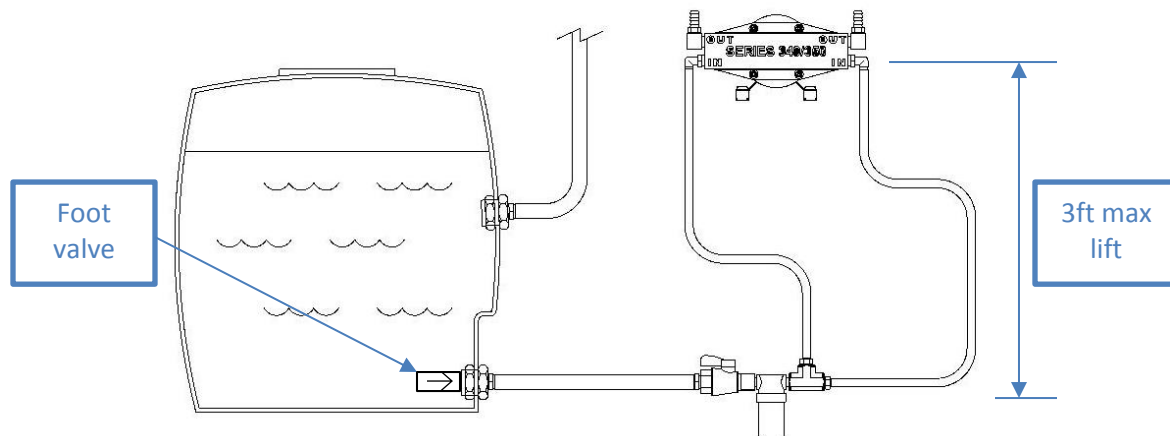

- The mounting plate should be made of steel or aluminum. It may be a horizontal or vertical mount plate (for vertical mounts, the pump must hang below the motor).
- Drill four holes in your mounting plate with a 5/16" drill bit. The hole pattern is 4 inches wide by 3.3 inches long.

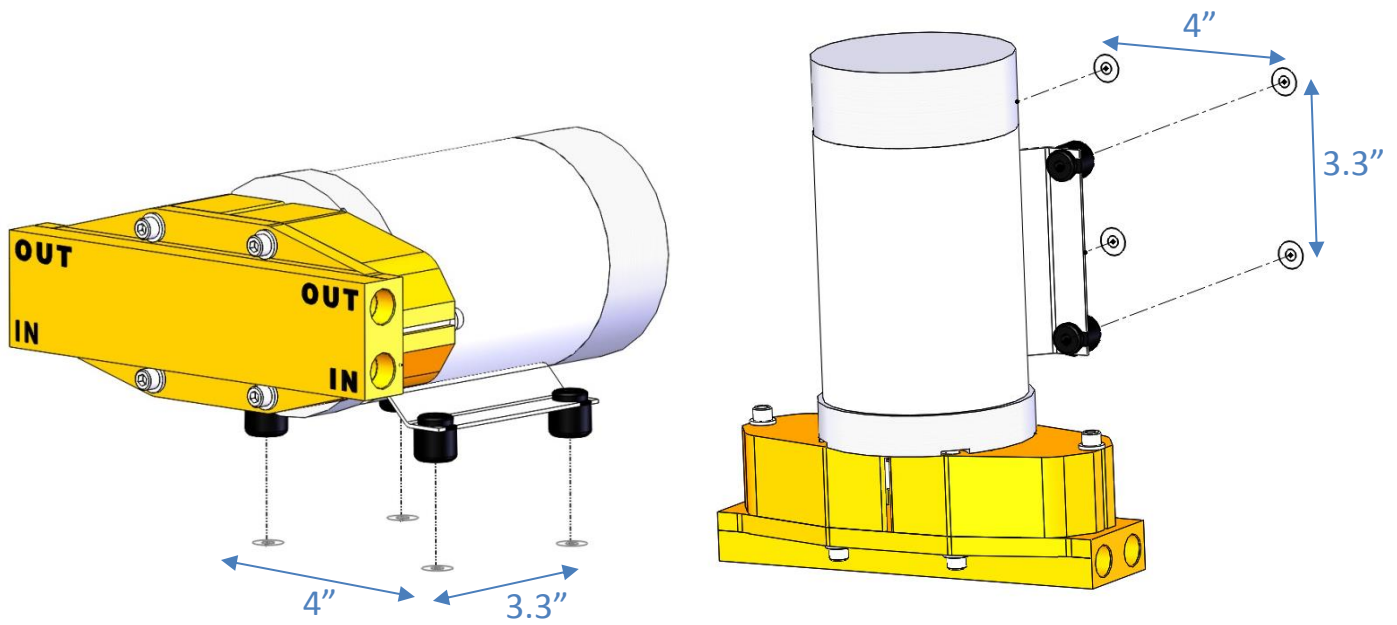

If mounting vertical, the pump should be below the motor, as shown.

STEP 2

Bolt regulator to a mounting plate.

- Choose a location where the operator can easily adjust the pressure regulator, view the pressure gauge, and operate priming ball-valve.
- Drill four holes in your mounting plate with a 5/16" drill bit. The hole pattern is 2 inches wide by 2.17 inches long.
- The regulator is designed to be mounted to a vertical surface. It may also be mounted to a horizontal surface if desired.
- The hose from the pump to the regulator must be at least 18" long of soft 200psi hose (up to 10ft long if needed).

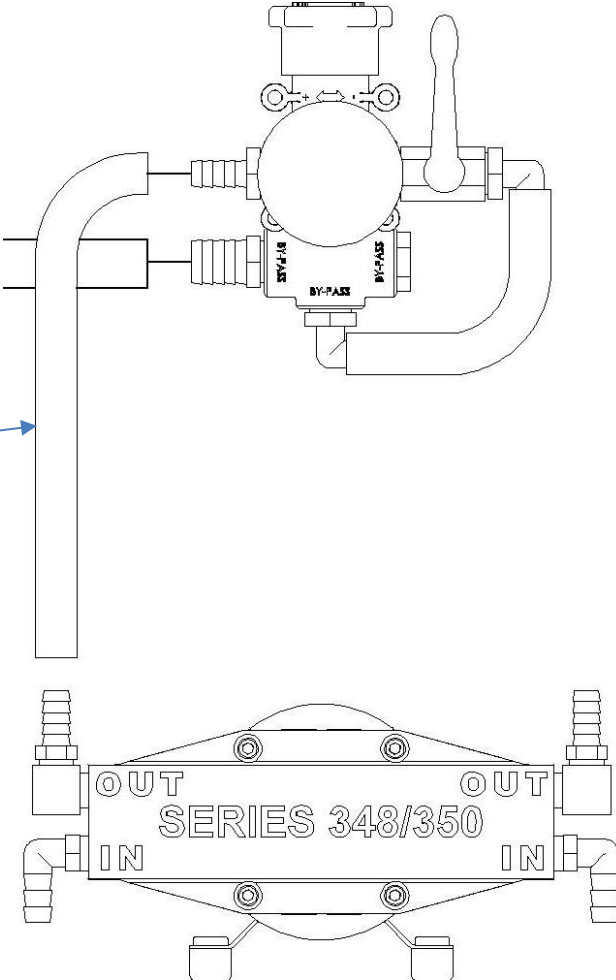
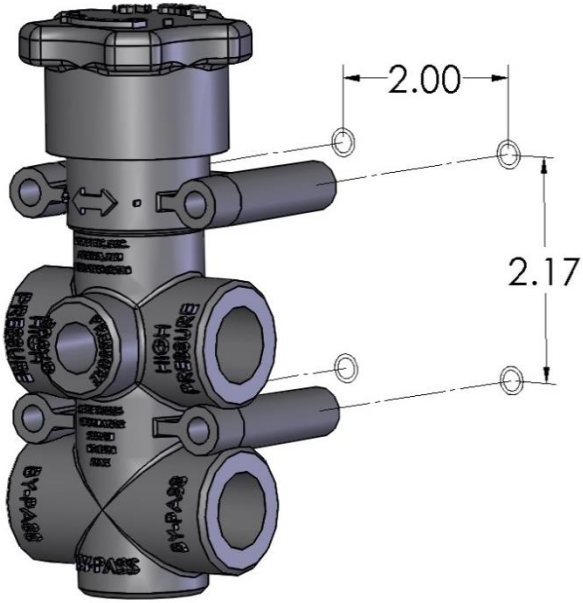

Soft 200psi hose.
At least 18" long.

STEP 3 Prepare tank.

- Your tank needs to have a $\frac{3}{4}$ " or larger feed port and a $\frac{3}{4}$ " or larger bypass return port.
- Install $\frac{3}{4}$ " NPT bulk-head fittings into your tank if either or both ports are not present.
- Also install $\frac{3}{4}$ " hose-barb fittings into each bulk-head fitting.
- Locate the bypass return port at least 12 inches away from the suction port. The bypass return port can be located above or below the liquid level.
- Take extra care securing your tank with suitable straps and/or supports that keep the tank from shifting during transport.

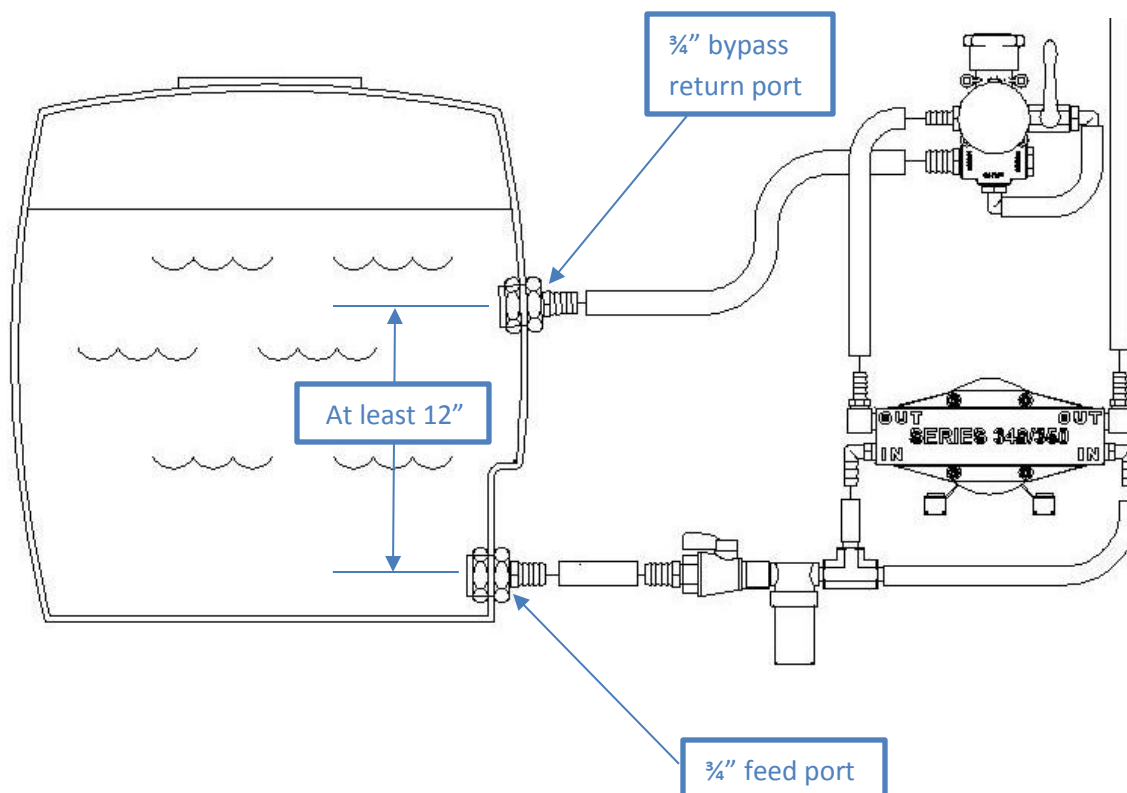

STEP 4

Connect feed, bypass, and discharge hoses.

- Connect a $\frac{3}{4}$ " hose from one of the the regulator ports marked "bypass" to the bypass return port on your tank.
- Connect a $\frac{3}{4}$ " suction line from the pump inlet shut off valve to the feed port on your tank. This hose should be reinforced flexible suction line that does not collapse under a vacuum. Maximum distance from tank to pump is 6 ft.
- Connect a $\frac{1}{2}$ " hose from the pump discharge barb to your hose reel or directly to your spray gun.
- Secure all hose ends with hose clamps to ensure no leaks.

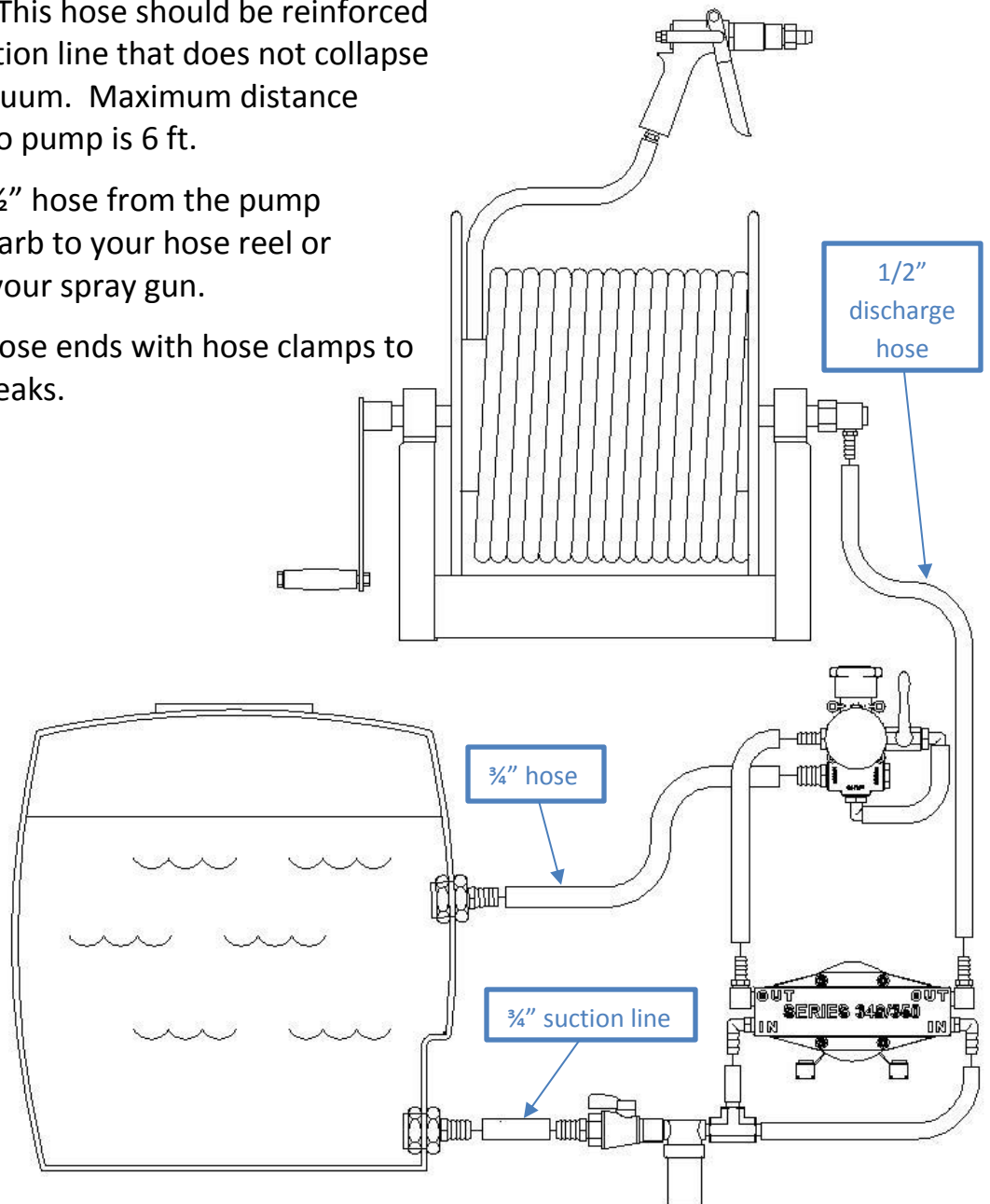

STEP 5

Connect motor wires to a 12VDC power circuit. (switch, fuse, and battery).

- Consult an automotive technician (certified to ASE T6 Truck Electrical/Electronic Systems) for final approval of wiring installation and electrical components.
- The wiring circuit must include an ON/OFF switch rated for 12VDC, 75 Amps or higher.
- The wiring circuit must include overload protection such as a fuse rated for 40 Amps.
- Use a 27 Series 12VDC Marine and RV Deep-Cycle battery. Suggested specs are 675 cold cranking amps and 180Ah of reserve capacity at 25Amps. (Example: Interstate SRM-27B).
- Use 8Ga. or heavier SAE 1127 type SGT wire rated to 105°C. Maximum total circuit length for 8Ga wire is 18ft (example: 9ft red wire + 9ft black wire = 18ft total circuit length). Longer circuits will require heavier wire.
- Take extra care to make sure wires are prevented from contacting sharp edges such as holes in sheet metal that may damage the wire insulation jacket. Use wire cover loom to bundle wires together and used clamps to secure in place.

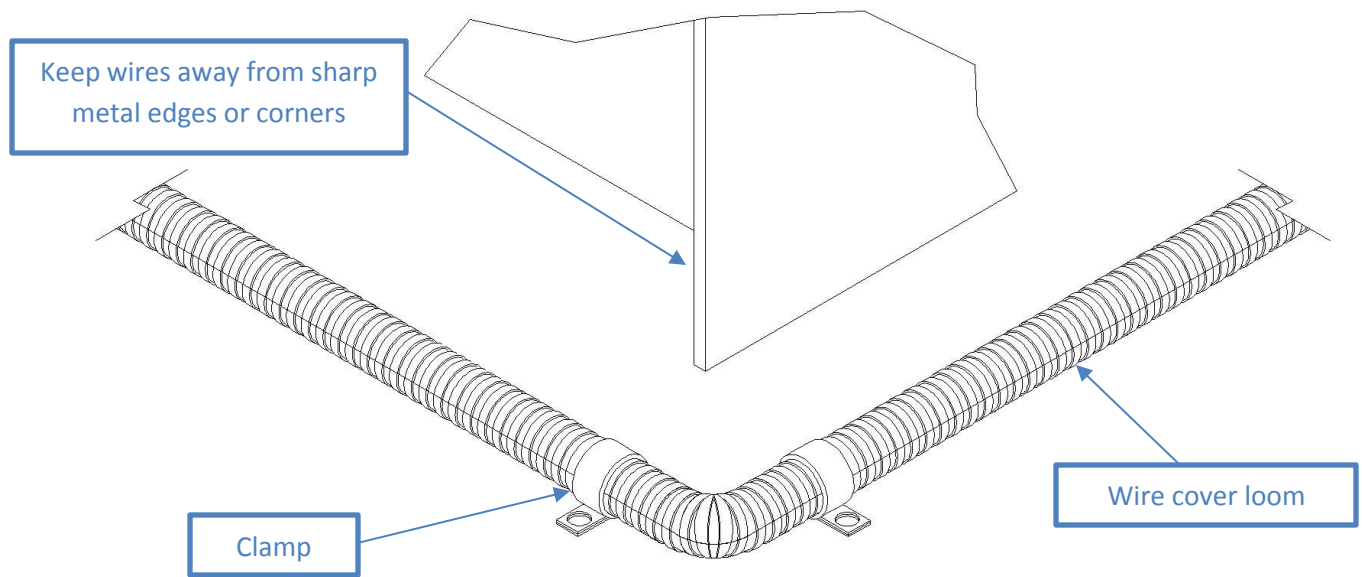

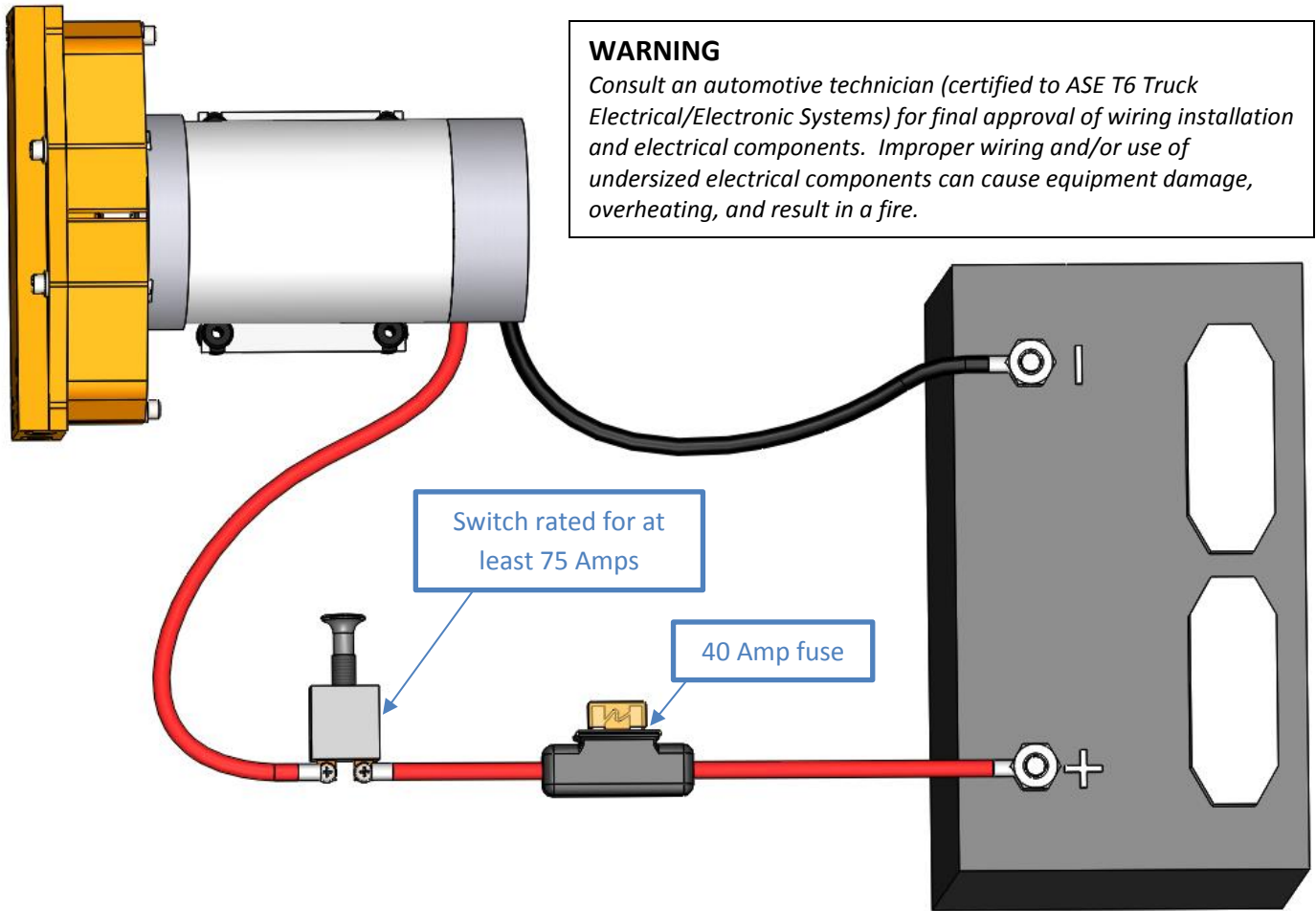

- It is not necessary to wire the pump to the vehicle battery. If you do choose to wire the pump to your vehicle battery, also consult your vehicle dealership before making any connections. Pumptec will not be responsible for any damage or harm to pump, vehicle, or persons resulting from improper installation.