



# TYPE "B" SINGLE STAGE CENTRIFUGAL PUMP Air Cooled Engine Drive Self Prime

Section	AC/SP
Page	130.1
Date	January 1, 2004
Supersedes 4/1/96	

## CAST IRON IMPELLER

## B4TQKLS-18

### Threaded Case (NPT)

### Mechanical Seal Construction

Distributed by  
PumpBiz, Inc.  
[www.PumpBiz.com](http://www.PumpBiz.com)  
800-PumpBiz  
(786-7249)

**TABLE I**

B/M No.	HP	Engine Manufacturer	Engine Part No.	Mounting Type & Part No.
<b>B71546</b>	18	B & S Vanguard	H05159	Base H05248

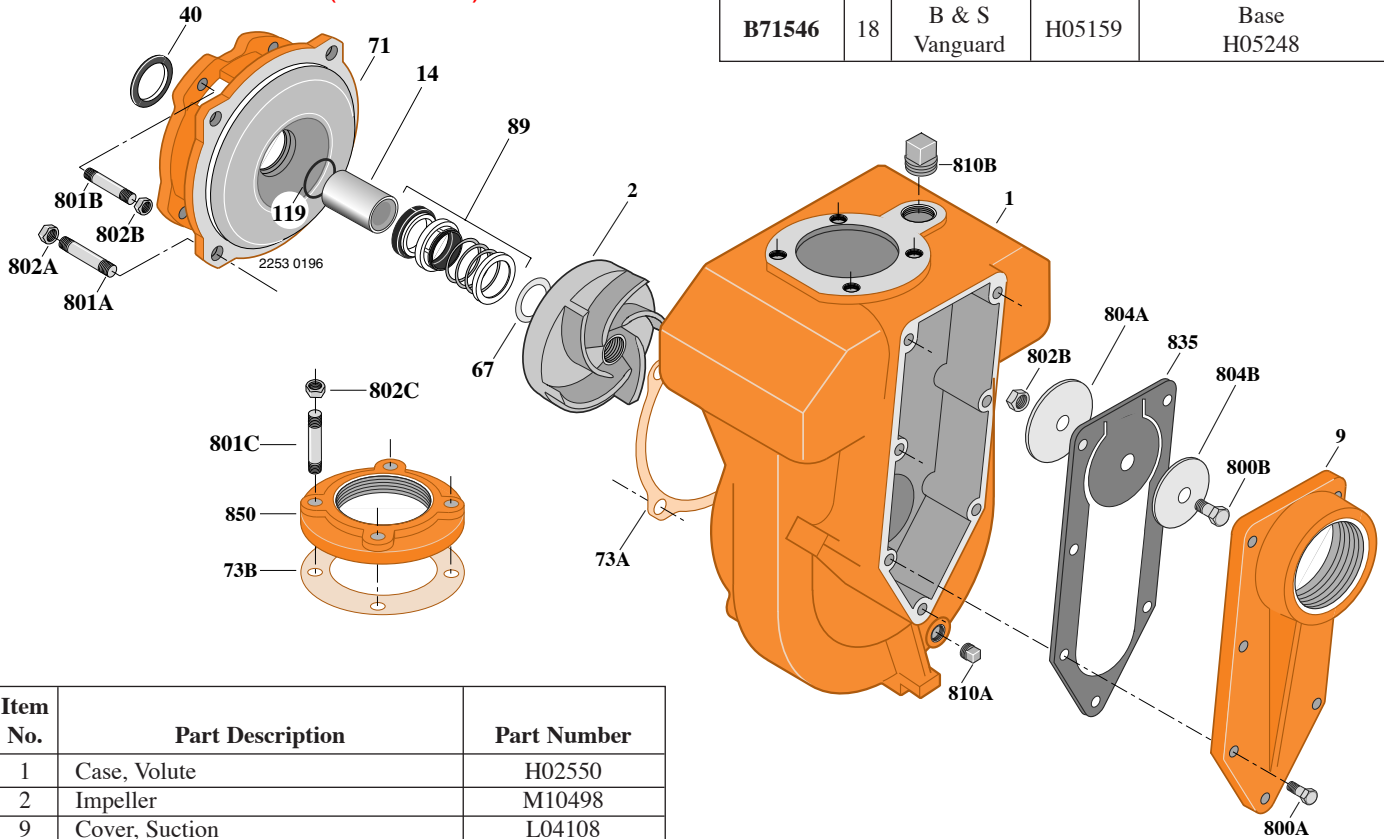

Item No.	Part Description	Part Number
1	Case, Volute	H02550
2	Impeller	M10498
9	Cover, Suction	L04108
14	Sleeve, Shaft	M10731
40	Slinger, Water	S03893
67	Shim (.015 Thick) (As Required)	S15335
71	Bracket	H05263
73A	Gasket, Case (.031 Thick)	S04757
73A	Gasket, Case (.051 Thick)	S15049
73B	Gasket, Companion Flange	S10364
89	Seal, Mechanical Shaft	S32014
119	O-Ring	M10728
800A	Capscrew, Hex 3/8-16x1-1/4" (7 Req.)	S26828
800B	Capscrew, Hex 3/8-16x3/4"	S26824
801A	Stud, 1/2-13x1-1/2" (4 Req.)	S24043
801B	Stud, 3/8-16x1-1/2" (4 Req.)	S23995
801C	Stud, 5/8-11x2-1/2" (4 Req.)	S24062
802A	Nut, Hex 1/2-13 (4 Req.)	S23107

Item No.	Part Description	Part Number
802B	Nut, Hex 3/8-20 (5 Req.)	S23103
802C	Nut, Hex 5/8-11 (4 Req.)	S23109
804A	Weight, Clack	S14842
804B	Washer, Clack	S15325
810A	Plug, Pipe 1/4" NPT	S23717
810B	Plug, Pipe 1-1/4" NPT	S23694
835	Clack, Rubber	L04119
850	Flange, Companion	S15933

**NOTE:** Refer to *Supplement A* for base configuration and mounting hardware.