

FRX 100

Centrifugal Pump

The FRX 100 316 stainless steel centrifugal pump is ideal for hard-to-handle applications in the marine, commercial, and industrial markets.

All wetted components are 316 investment cast stainless steel providing superior corrosion resistance when pumping chemical compounds. A carbon, ceramic, viton bellows shaft seal is standard with optional seals available on request. The FRX 100 model is available with 1" NPT port configurations. Pump rotation in 90° increments.

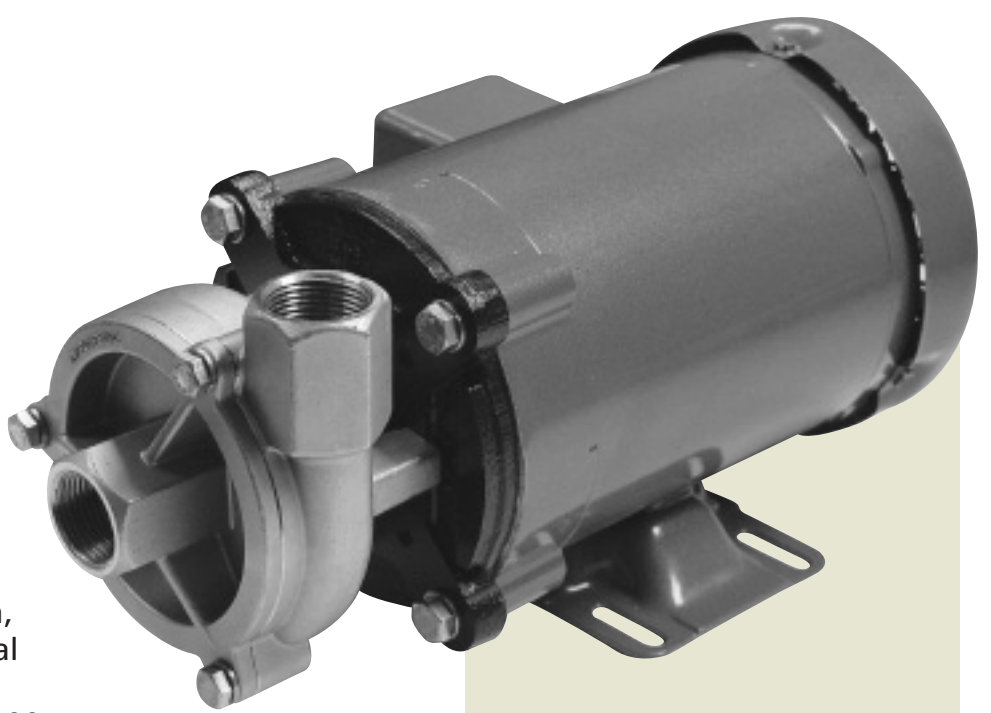

SPECIFICATIONS:

Housing	316 Stainless Steel (Investment Cast)
Cover	316 Stainless Steel (Investment Cast)
Impeller	316 Stainless Steel Enclosed (Investment Cast)
Mechanical Seal . .	Carbon/Ceramic/Viton Bellows 150 PSI Special Seals Upon Request
O-ring	Viton
Motor	56J Single and Three Phase TEFC
Weight	31 lbs.

Application:

- Marine
- Industrial
- Commercial

Construction:

- 316 Stainless Steel Investment Cast

C FACE 56J

Motor Options:

- TEFC

Port Sizes:

- 1" NPT

Seal:

- Carbon / Ceramic / Viton

FRX 100

