



Distributed by;  
PumpBiz, Inc.  
800-PumpBiz  
www.PumpBiz.com

# User's Manual

# TP03 HYDRAULIC TRASH PUMP

MODEL: TP0300301, TP0300303

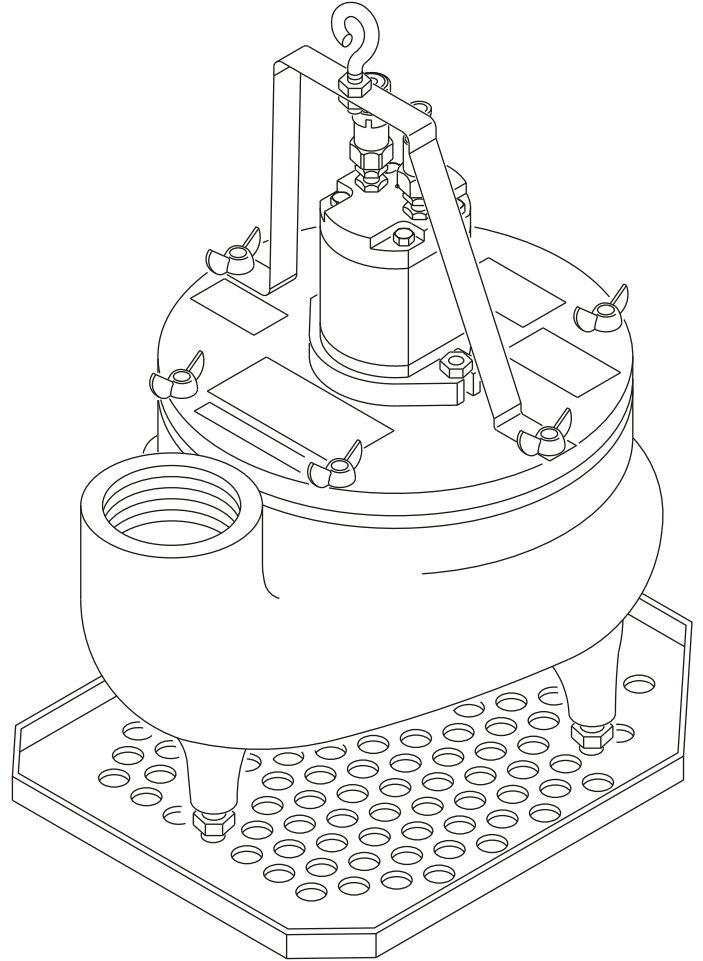

Copyright © 2001 The Stanley Works  
OPS USA & CE Version  
58555 7/2002 Ver. 2

## **⚠ DANGER**

**SERIOUS INJURY OR DEATH COULD RESULT FROM THE IMPROPER REPAIR OR SERVICE OF THIS TOOL.**

**REPAIRS AND/OR SERVICE TO THIS TOOL MUST ONLY BE DONE BY AN AUTHORIZED AND CERTIFIED DEALER.**

---

# Table of Contents

---

# TPO3

## Hydraulic Trash Pump

### **SERVICING THE TP03 Hydraulic Trash Pump**

This manual contains Safety, Operation, and Troubleshooting information. Stanley Hydraulic Tools recommends that servicing of hydraulic tools, other than routine maintenance, must be performed by an authorized and certified dealer. Please read the DANGER warning on the cover and the

Certificate of Conformity	3
Specifications	3
General Safety Instructions	4
Tools Decals and Tags	5
Hydraulic Hose Requirements	6
HTMA Requirements	7
Operating Instructions	8
Troubleshooting	10
Parts Illustration	11
Parts List	12
Accessories	12
Warranty	13

Copyright ©2001 The Stanley Works  
All rights reserved.

Under copyright law, this document may not be copied in whole or in part without the prior written consent of The Stanley Works. This exception does not permit copies to be made for others, whether or not sold. Under the law, copying includes translating into another language, format or medium. This copyright notice must appear on any permitted copies.

## **SAFETY FIRST**

***It is the responsibility of the operator and service technician to read rules and instructions for safe and proper operation and maintenance.***

***A cautious worker using common sense is the greatest safety device.***



---

# General Safety Instructions

---

*Always observe safety symbols. They are included for your safety and the protection of the tool.*



This tool will provide safe and dependable service if operated in accordance with the instructions given in this manual. Read and understand this manual and any stickers and tags attached to the tool and hoses before operation. Failure to do so could result in personal injury or equipment damage.

- Operator must start in a work area without bystanders. The operator must be familiar with all prohibited work areas such as excessive slopes and dangerous terrain conditions.
- Establish a training program for all operators to ensure safe operations.
- Do not operate the tool unless thoroughly trained or under the supervision of an instructor.
- Always wear safety equipment such as goggles, head protection, and safety shoes at all times when operating the tool.
- Do not inspect or clean the tool while the hydraulic power source is connected. Accidental engagement of the tool can cause serious injury.
- Do not operate this tool without first reading the Operating Instructions.
- Do not install or remove this tool while the hydraulic power source is connected. Accidental engagement of the tool can cause serious injury.
- Never operate the tool if you cannot be sure that underground utilities are not present. Underground electrical utilities present an electrocution hazard. Underground gas utilities present an explosion hazard. Other underground utilities may present other hazards.
- Do not wear loose fitting clothing when operating the tool. Loose fitting clothing can get entangled with the tool and cause serious injury.
- Supply hoses must have a minimum working pressure rating of 2500 psi/175 bar.
- Be sure all hose connections are tight.
- The hydraulic circuit control valve must be in the “OFF” position when coupling or uncoupling the tool. Wipe all couplers clean before connecting. Failure to do so may result in damage to the quick couplers and cause overheating. Use only lint-free cloths.
- Do not operate the tool at oil temperatures above 140° F/60° C. Operation at higher oil temperatures can cause operator discomfort and may cause damage to the tool.
- Do not operate a damaged, improperly adjusted, or incompletely assembled tool.
- To avoid personal injury or equipment damage, all tool repair, maintenance and service must only be performed by authorized and properly trained personnel.
- Do not exceed the rated limits of the tool or use the tool for applications beyond its design capacity.
- Always keep critical tool markings, such as labels and warning stickers legible.
- Always replace parts with replacement parts recommended by Stanley Hydraulic Tools.
- Check fastener tightness often and before each use daily.

# Tool Decals & Tags

A Name Tag Sticker is attached to the tool. Never exceed the flow and pressure levels specified on this sticker. The information listed on the name tag sticker must be legible at all times. Replace this sticker if it becomes worn or damaged. A replacement is available from your local Stanley distributor.

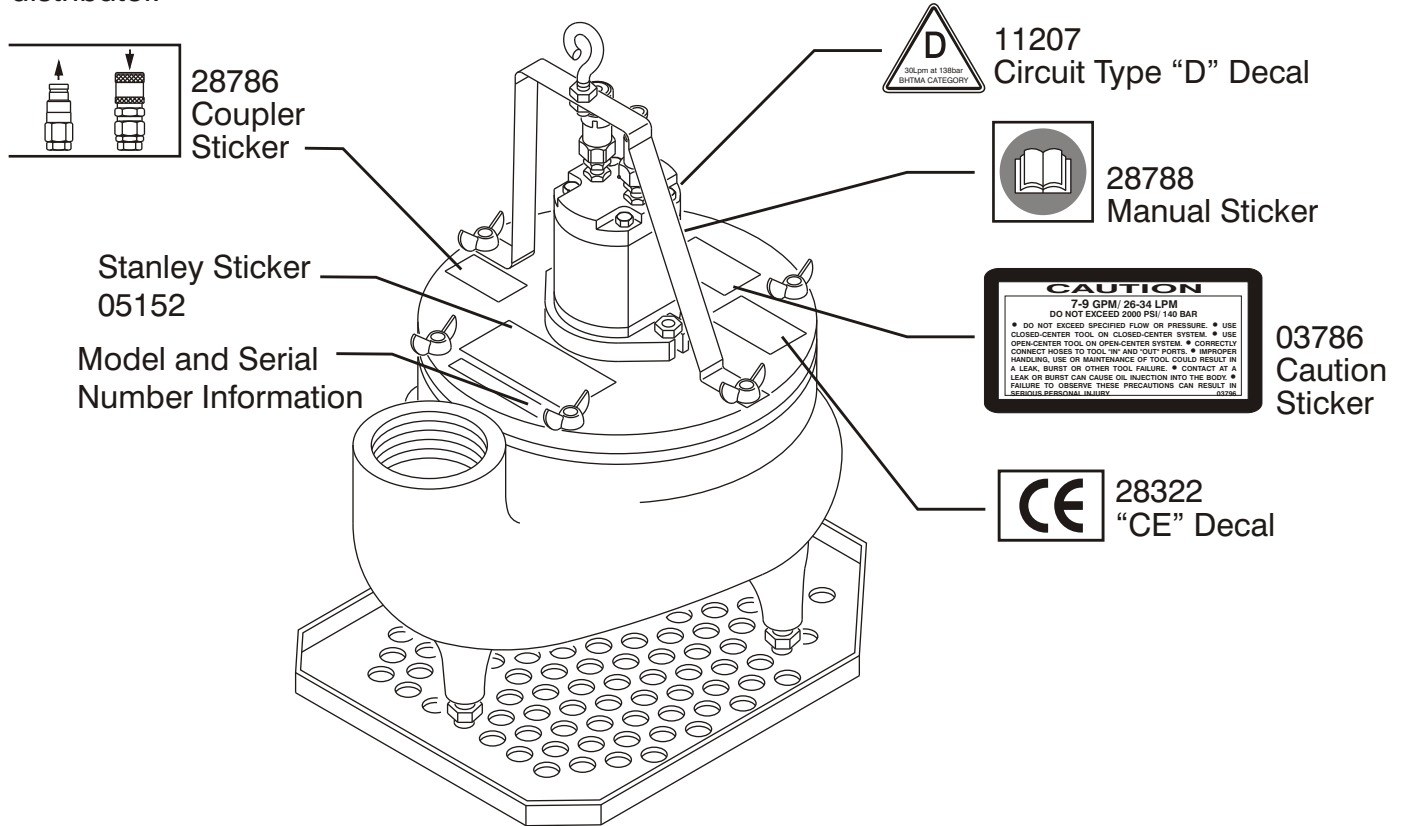

The SAFETY TAG, P/N 15875, shown at right, smaller than actual size, is attached to the tool when shipped from the factory. Read and understand the safety instructions listed on this tag before removal. We suggest you retain this tag and attach it to the tool when not in use.

**DANGER**

- FAILURE TO USE HYDRAULIC HOSE LABELED AND CERTIFIED AS NON-CONDUCTIVE WHEN USING HYDRAULIC TOOLS ON OR NEAR ELECTRICAL LINES MAY RESULT IN DEATH OR SERIOUS INJURY. BEFORE USING HOSE LABELED AND CERTIFIED AS NON-CONDUCTIVE ON OR NEAR ELECTRICAL LINES, BE SURE THE HOSE IS MAINTAINED AS NON-CONDUCTIVE. THE HOSE SHOULD BE REGULARLY TESTED FOR ELECTRIC CURRENT LEAKAGE IN ACCORDANCE WITH YOUR SAFETY DEPARTMENT INSTRUCTIONS.
- A HYDRAULIC LEAK OR BURST MAY CAUSE OIL INJECTION INTO THE BODY OR CAUSE OTHER SEVERE PERSONAL INJURY.
  - DO NOT EXCEED SPECIFIED FLOW AND PRESSURE FOR THIS TOOL. EXCESS FLOW OR PRESSURE MAY CAUSE A LEAK OR BURST.
  - DO NOT EXCEED RATED WORKING PRESSURE OF HYDRAULIC HOSE USED WITH THIS TOOL. EXCESS PRESSURE MAY CAUSE A LEAK OR BURST.
  - CHECK TOOL HOSE COUPLERS & CONNECTORS DAILY FOR LEAKS. DO NOT FEEL FOR LEAKS WITH YOUR HANDS. CONTACT WITH A LEAK MAY RESULT IN SEVERE PERSONAL INJURY.

**IMPORTANT**

READ OPERATION MANUAL AND SAFETY INSTRUCTIONS FOR THIS TOOL BEFORE USING IT.

USE ONLY PARTS AND REPAIR PROCEDURES APPROVED BY STANLEY AND DESCRIBED IN THE OPERATION MANUAL.

TAG TO BE REMOVED ONLY BY TOOL OPERATOR.

(517) SEE OTHER SIDE 15875

**DANGER**

- DO NOT LIFT OR CARRY TOOL BY THE HOSES. DO NOT ABUSE HOSE. DO NOT USE KINKED, TORN OR DAMAGED HOSES.
- MAKE SURE HYDRAULIC HOSES ARE PROPERLY CONNECTED TO THE TOOL BEFORE PRESSURIZING SYSTEM. SYSTEM PRESSURE HOSE MUST ALWAYS BE CONNECTED TO TOOL "IN" PORT. SYSTEM RETURN HOSE MUST ALWAYS BE CONNECTED AT TOOL "OUT" PORT. REVERSING CONNECTIONS MAY CAUSE REVERSE TOOL OPERATION WHICH CAN CAUSE SEVERE PERSONAL INJURY.
- DO NOT CONNECT CLOSED-CENTER TOOLS TO OPEN-CENTER HYDRAULIC SYSTEMS. THIS MAY CAUSE EXTREME SYSTEM HEAT AND/OR SEVERE PERSONAL INJURY. DO NOT CONNECT OPEN-CENTER TOOLS TO CLOSED-CENTER HYDRAULIC SYSTEMS. THIS MAY RESULT IN LOSS OF OTHER HYDRAULIC FUNCTIONS POWERED BY THE SAME SYSTEM AND/OR SEVERE PERSONAL INJURY.
- BYSTANDERS MAY BE INJURED IN YOUR WORK AREA. KEEP BYSTANDERS CLEAR OF YOUR WORK AREA.
- WEAR HEARING, EYE, FOOT, HAND AND HEAD PROTECTION.
- TO AVOID PERSONAL INJURY OR EQUIPMENT DAMAGE, ALL TOOL REPAIR, MAINTENANCE AND SERVICE MUST BE PERFORMED BY AUTHORIZED AND TRAINED PERSONNEL.

**IMPORTANT**

READ OPERATION MANUAL AND SAFETY INSTRUCTIONS FOR THIS TOOL BEFORE USING IT.

USE ONLY PARTS AND REPAIR PROCEDURES APPROVED BY STANLEY AND DESCRIBED IN THE OPERATION MANUAL.

TAG TO BE REMOVED ONLY BY TOOL OPERATOR.

(517) SEE OTHER SIDE 15875

# Hydraulic Hose Requirements

## HOSE TYPES

Hydraulic hose types authorized for use with Stanley Hydraulic Tools are as follows:

- 1 Certified non-conductive
- 2 Wire-braided (conductive)
- 3 Fabric-braided (not certified or labeled non-conductive)

Hose 1 listed above is the only hose authorized for use near electrical conductors.

Hoses 2 and 3 listed above are **conductive** and **must never** be near electrical conductors.

## HOSE SAFETY TAGS

To help ensure your safety, the following DANGER tags are attached to all hoses purchased from Stanley Hydraulic Tools. **DO NOT REMOVE THESE TAGS.**

If the information in a tag is illegible because of wear or damage, replace the tag immediately. A new tag may be obtained at no charge from your Stanley Distributor.

### This Tag attached to “Certified Non-Conductive” hose.

(shown smaller than actual size) p/n 27987

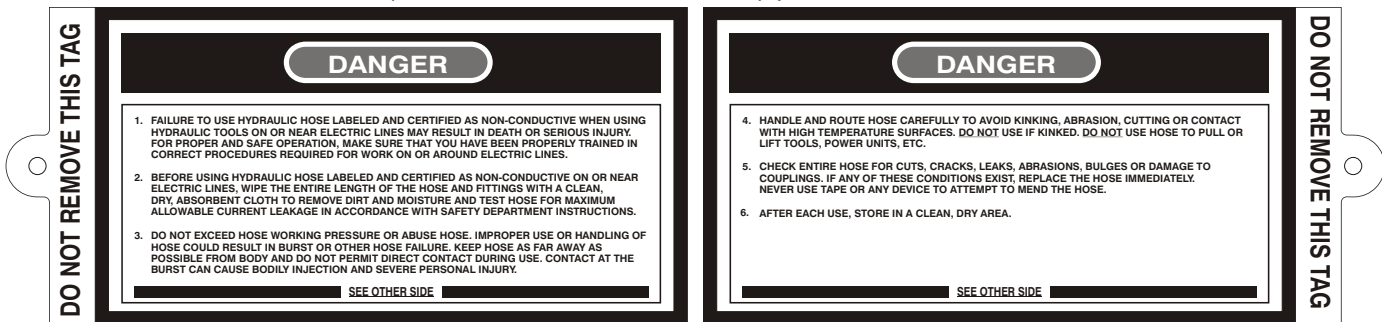

Side 1

Side 2

### This Tag attached to “Conductive” hose.

(shown smaller than actual size) p/n 29144

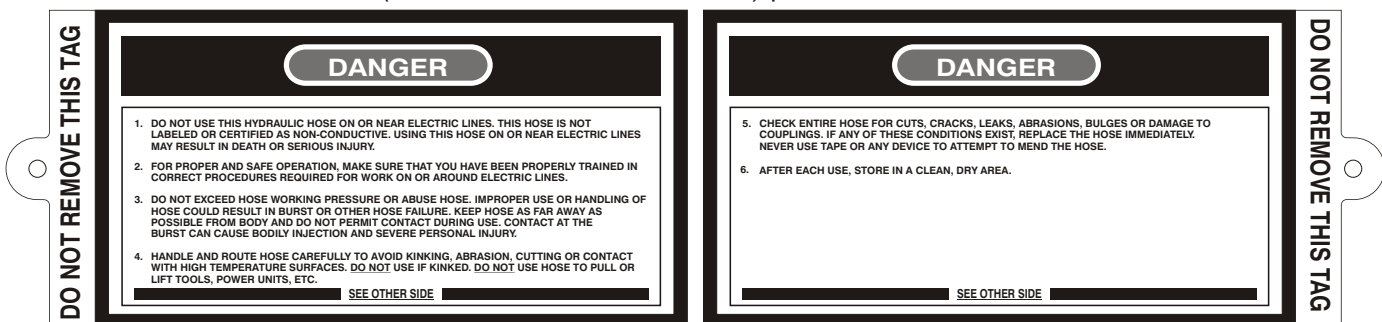

Side 1

Side 2

## HOSE PRESSURE RATING

The rated working pressure of the hydraulic hose must be equal to or higher than the relief valve setting on the hydraulic system.

# HTMA Requirements

**NOTE:** These are general hydraulic system requirements. See tool specification page for tool specific requirements.

Hydraulic System Requirements	Tool Category:		Type III
	C	D	
	Type I	Type II	Type III
<b>Flow rate</b> Tool Operating Pressure <i>(at the power supply outlet)</i>	4-6 GPM (15-23 lpm) 2000 psi (138 bar)	7-9 GPM (26-34 lpm) 2000 psi (138 bar)	11-13 GPM (42-49 lpm) 2000 psi (138 bar)
<b>System relief valve setting</b> <i>(at the power supply outlet)</i>	2100-2250 (145-155 bar)	2100-2250 (145-155 bar)	2100-2250 (145-155 bar)
<b>Maximum back pressure</b> <i>(at tool end of the return hose)</i>  Measured at a max. fluid viscosity of: <i>(at min. operating temperature)</i>	250 psi (17 bar)  400 SSU (82 centistokes)	250 psi (17 bar)  400 SSU (82 centistokes)	250 psi (17 bar)  400 SSU (82 centistokes)
<b>Temperature</b> Sufficient heat rejection capacity to limit max. fluid temperature to: <i>(at max. expected ambient temperature)</i>  Min. cooling capacity at a temperature difference of between ambient and fluid temps	140° F (60° C)  3 hp (2.24 kW) 40° F (22° C)	140° F (60° C)  5 hp (3.73 kW) 40° F (22° C)	140° F (60° C)  7 hp (5.22 kW) 40° F (22° C)
<b>Filter</b> Min. full-flow filtration sized for flow of at least: <i>(For cold temp. startup and max. dirt-holding capacity)</i>	25 microns 30 GPM (114 lpm)	25 microns 30 GPM (114 lpm)	25 microns 30 GPM (114 lpm)
<b>Hydraulic fluid</b> Petroleum based <i>(premium grade, anti-wear, non-conductive)</i> Viscosity <i>(at min. and max. operating temps)</i>	100-400 SSU* (20-82 centistokes)	100-400 SSU* (20-82 centistokes)	100-400 SSU* (20-82 centistokes)
<b>NOTE:</b> Do not operate the tool at oil temperatures above 140° F (60° C). Operation at higher temperatures can cause operator discomfort at the tool.			
<b>NOTE:</b> When choosing hydraulic fluid, the expected oil temperature extremes that will be experienced in service determine the most suitable temperature viscosity characteristics. Hydraulic fluids with a viscosity index over 140 will meet the requirements over a wide range of operating temperatures.			

\*SSU = Saybolt Seconds Universal

**NOTE:** These are general hydraulic system requirements. See tool Specification page for tool specific requirements.



# Operating Instructions

## Pre-operation Procedures

### Check The Power Source

1. Using the calibrated flowmeter and pressure gauge, check that the hydraulic power source develops a flow of 7-9 gpm/26-34 lpm at 1500-2000 ps/105-140 bar.
2. Make certain the hydraulic power source is equipped with a relief valve set to crack at 2150-2250 psi/150-155 bar maximum.
3. Check that the pump inlet is clear of debris. Remove any obstructions before operating the pump. Refer to **CLEANING THE PUMPING CHAMBER**.

### Connect Hoses

1. Wipe all hose couplers with a clean lint-free cloth before making connections.

#### **CAUTION**

*Do not connect pressure to the return port. Motor shaft seal limit is 250 psi/17 bar.*

2. Connect the hoses from the hydraulic power source to the couplers on the pump or pump hoses. It is a good practice to connect return hoses first and disconnect them last to minimize or avoid trapped pressure in the pump motor.

**NOTE: If uncoupled hoses are left in the sun, heat may cause a pressure increase inside the hoses making them difficult to connect. When possible, connect the free ends of the operating hoses together.**

3. If hose couplers are used, observe the arrow on the coupler to ensure that the flow is in the proper direction. The female coupler on the pump is the inlet coupler.

## Pump Operation

1. Observe all safety precautions.
2. Attach a 3-inch/76 mm diameter discharge hose to the pump outlet. For the best performance, keep the discharge hose as short as possible and lay it out to avoid sharp bends or kinks.

*Do not* attach a nozzle to the outlet of the discharge hose. For high-pressure water pumping, use a Stanley SM20 and nozzle. The TP03 is designed for high gpm water flow at low pressure.

3. Attach a rope or cable to the lifting eye at the top of the pump. Lower the pump into the liquid to be pumped. Do not raise or lower the pump by its hoses or couplers to avoid damage to the hoses or couplers.

#### **WARNING**

*Never point the hose at bystanders.*

4. Turn on the hydraulic power source.

**NOTE: It will not damage the pump to run it "DRY"**

5. When pumping is completed, set the hydraulic on/off valve at the hydraulic power source to **OFF**. Lift the pump from the liquid using the rope or cable.

#### **CAUTION**

*Perform steps 6 thru 8 for pump protection and care.*

6. The pump must maintain a minimum RPM and water speed to move solid particles through the pump (high speed water is required to push solids through the large pump). When pumping liquids containing large solids, monitor the flow from the outlet of the discharge hose. If it begins to slow turn off the hydraulic power source and raise the pump. Disconnect the hydraulic hoses. See **CLEANING THE PUMPING CHAMBER**.



---

# Operating Instructions

---

## **⚠ CAUTION**

*Pumping liquids with a solids-to-liquid ratio greater than 30% solids to 70% liquid will accelerate impeller wear.*

7. To maintain performance it is good practice to periodically inspect the impeller for wear or damage. This is especially important following the pumping of liquids containing sharp, abrasive solids.
8. Turn off the hydraulic power source before raising the pump. Raise the pump by the rope or cable attached to its top to avoid damaging the hoses and couplings.
2. Clear the debris and determine whether or not the discharge hose is clogged or the power source is not providing adequate flow/pressure to properly drive the pump. If the pump is not cleared, heavy solids will not be removed from the pump, eventually damaging or destroying the impeller.
3. Place the motor adapter plate over the case studs.
4. Install the handle and lifting eye on the motor adapter plate and secure with six 3/8-16 wing nuts. Tighten by hand only.
5. Install the hoses and couplers.

## **Cold Weather Operation**

If the pump is to be used during cold weather, preheat the hydraulic fluid at low engine speed. When using the normally recommended fluids, fluid should be at or above 50°F/10°C (400 ssu/82 centistrokes) before use.

Damage to the hydraulic system or pump motor could result from using fluid that is too viscous or thick.

## **Cleaning The Pumping Chamber**

1. Remove the six 3/8-16 wing nuts securing the motor adapter plate and motor to the case.

**NOTE: A slot has been milled in the underside of the aluminum motor adapter plate near the pump outlet. This slot allows air near the impeller to be submerged and prevents binding.**

**Inspect this slot before each use to ensure that no obstruction blocks this vent slot.**

It is normal for a small amount of water to squirt from this slot while pumping.

# Troubleshooting

This section describes how to find and resolve problems users may experience. If a situation occurs that is not covered, call your Stanley Customer Service representative for assistance.

## **WARNING**

*Inspecting the tool or installing parts with the hydraulic hoses connected can result in severe personal injury or equipment damage.  
To prevent accidental startup, disconnect the hydraulic power before beginning any inspection or installation task.*

If symptoms of poor performance develop, the following chart can be used as a guide to correct the problem.

When diagnosing faults in operation of the tool, always check that the hydraulic power source is supplying the correct hydraulic flow and pressure to the tool as listed in the table. Use a flowmeter known to be accurate. Check the flow with the hydraulic oil temperature at least 80° F/27° C.

Symptom	Possible Cause	Solution
Tool will not start.	No hydraulic flow or pressure.	Turn on power source and check that 7-9 gpm / 26-34 lpm at 1500-2000 psi / 101-140 bar is available at the pump.
	Defective couplers.	Check the couplers by connecting them together with the hydraulic power source operating and the control valve "ON". The power supply should operate without "loading" from plugged couplers.
	Impeller jammed with debris.	Clean the pumping chamber as described in the OPERATING INSTRUCTIONS section of this manual.
	Motor failure.	Contact Authorized Distributor.
Poor tool performance.	Incorrect hydraulic flow or pressure.	Turn "ON" power source, check that 7-9 gpm/ 26-34 lpm at 1500-2000 psi/ 101-149 bar is available at the pump.
	Inlet to pump may be blocked.	Inspect and clear. If pump settled into sediment, suspend pump above sediment or place flat, solid surface under the pump.
	Discharge hose restricted.	Straighten hose and remove kinks.
	Impeller worn excessively.	Contact Authorized Distributor.
Hydraulic oil in discharge flow.	Motor shaft seal failure.	Contact Authorized Distributor.

# TP03 Parts Illustration

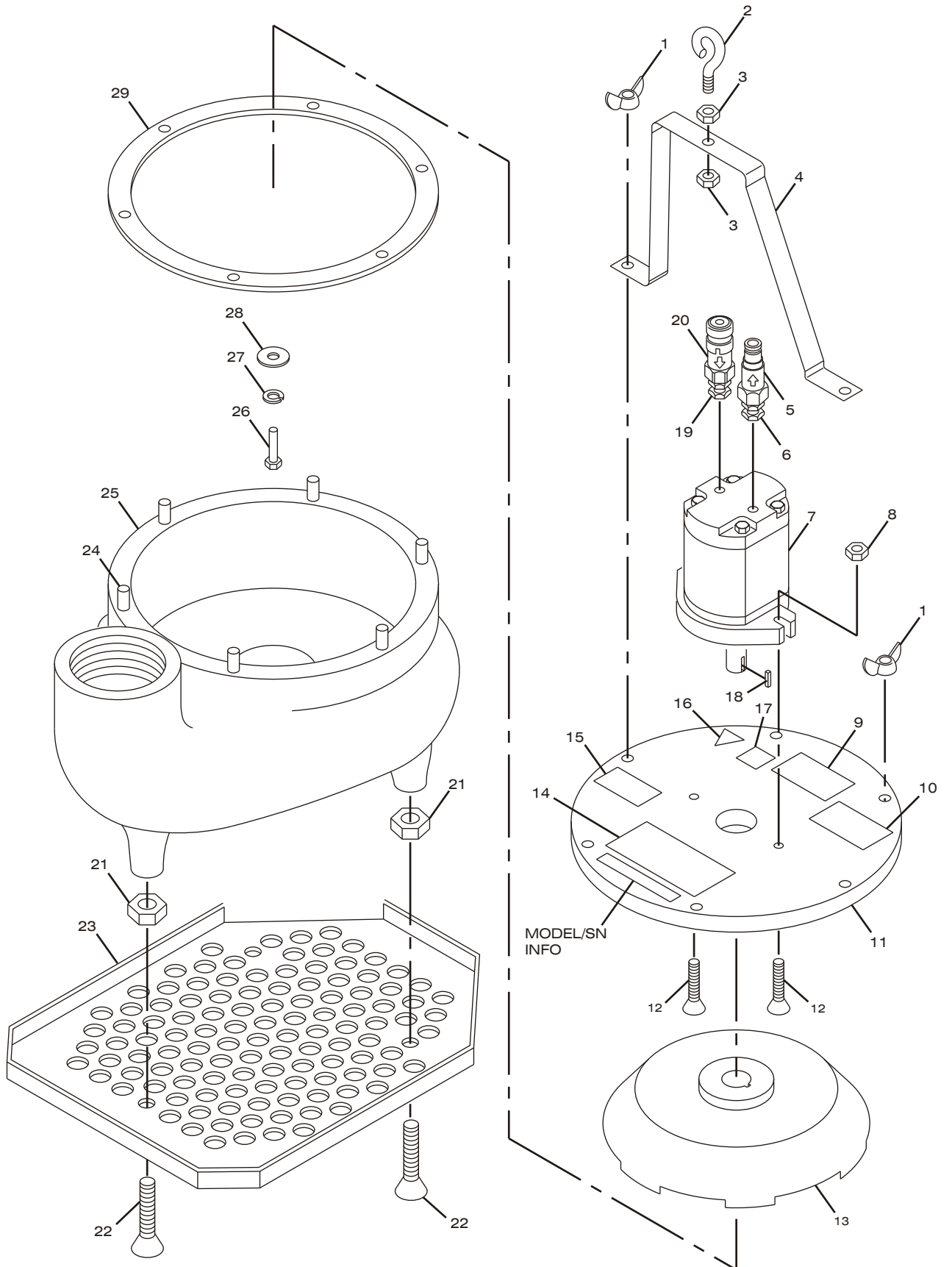

# TP03 Parts List

**NOTE:** Earlier models of the TP03 used a “DOWTY or HEMA” motor. If you are currently using a earlier TP03 with either of these motors installed, see your Authorized Distributor to obtain a correct manual (Manual P/N-07218).

**NOTE:**  
Use **Part Number** and **Description** when ordering.

Item	Part No.	Description	QTY
1	07210	Wing Nut, 3/ 8-16- TP03	6
2	07208	Eye Bolt, 3/8-16- TP03	1
3	371503	Nut 3/8-16 UNC PLT	2
4	07207	Handle- TP03	1
5	24061	Male Coupler	1
6	06264	Adaptor Fit. -12/1/2 NPT	1
7	24381	TP03 Motor Cassapa	1
8	04353	Nut, 3/8-16 ESNA	2
9	03786	GPM Sticker	1
10	28322	Sticker “CE” 25 mm	1
11	07202	Motor Adapter Plate	1
12	21978	Capscrew 3/8-16 x 1.75	2
13	07200	Impeller-TP03	1
14	05152	Stanley Sticker	1
15	28786	Coupler Sticker	1
16	11207	Circuit Type D Sticker	1
17	28788	Manual Sticker	1
18	00635	Key, Motor Shaft, 3/16 x 3/4	1
19	39426	Adaptor -14 SAE / 1/2NPT	1
20	24060	Female Coupler	1
21	38702	Jam Nut, 1/ 2-13 Zinc	3
22	38701	Screw, Slot FHMS	3
23	07206	Pump Support- TP03	1
24	07209	Stud, 3/8-16 x 2- TP03	6
25	21917	Urethane Bowl	1
	51301	TP0300303 (Venezuelan Army Only)	1
26	09661	Capscrew- TP04	1
27	01324	Lockwasher	1
28	22294	Washer	1
29	07201	Rubber Gasket- Tp03	1
	26230	<b>Seal Kit</b>	1

## Accessories

**NOTE:**  
Use **Part Number** and **Description** when ordering.

Part	Description
56761	3 inch x 25 ft Lay-Flat Cam-Lock Hose
52720	3 inch Male Pipe x 3 in Male Cam-Lock Fitting

---

# Warranty

---

Stanley Hydraulic Tools (hereinafter called "Stanley"), subject to the exceptions contained below, warrants new hydraulic tools for a period of one year from the date of sale to the first retail purchaser, or for a period of 2 years from the shipping date from Stanley, whichever period expires first, to be free of defects in material and/or workmanship at the time of delivery, and will, at its option, repair or replace any tool or part of a tool, or new part, which is found upon examination by a Stanley authorized service outlet or by Stanley's factory in Milwaukie, Oregon to be DEFECTIVE IN MATERIAL AND/OR WORKMANSHIP.

## EXCEPTIONS FROM WARRANTY

**NEW PARTS:** New parts which are obtained individually are warranted, subject to the exceptions herein, to be free of defects in material and/or workmanship at the time of delivery and for a period of 6 months after the date of first usage. Seals and diaphragms are warranted to be free of defects in material and/or workmanship at the time of delivery and for a period of 6 months after the date of first usage or 2 years after the date of delivery, whichever period expires first. Warranty for new parts is limited to replacement of defective parts only. Labor is not covered.

**FREIGHT COSTS:** Freight costs to return parts to Stanley, if requested by Stanley for the purpose of evaluating a warranty claim for warranty credit, are covered under this policy if the claimed part or parts are approved for warranty credit. Freight costs for any part or parts which are not approved for warranty credit will be the responsibility of the individual.

**SEALS & DIAPHRAGMS:** Seals and diaphragms installed in new tools are warranted to be free of defects in material and/or workmanship for a period of 6 months after the date of first usage, or for a period of 2 years from the shipping date from Stanley, whichever period expires first.

**CUTTING ACCESSORIES:** Cutting accessories such as breaker tool bits are warranted to be free of defects in material and or workmanship at the time of delivery only.

**ITEMS PRODUCED BY OTHER MANUFACTURERS:** Components which are not manufactured by Stanley and are warranted by their respective manufacturers.

- a. Costs incurred to remove a Stanley manufactured component in order to service an item manufactured by other manufacturers.

**ALTERATIONS & MODIFICATIONS:** Alterations or modifications to any tool or part. All obligations under this warranty shall be terminated if the new tool or part is altered or modified in any way.

**NORMAL WEAR:** Any failure or performance deficiency attributable to normal wear and tear such as tool bushings, retaining pins, wear plates, bumpers, retaining rings and plugs, rubber bushings, recoil springs, etc.

**INCIDENTAL/CONSEQUENTIAL DAMAGES:** To the fullest extent permitted by applicable law, in no event will STANLEY be liable for any incidental, consequential or special damages and/or expenses.

**FREIGHT DAMAGE:** Damage caused by improper storage or freight handling.

**LOSS TIME:** Loss of operating time to the user while the tool(s) is out of service.

**IMPROPER OPERATION:** Any failure or performance deficiency attributable to a failure to follow the guidelines and/or procedures as outlined in the tool's operation and maintenance manual.

**MAINTENANCE:** Any failure or performance deficiency attributable to not maintaining the tool(s) in good operating condition as outlined in the Operation and Maintenance Manual.

**HYDRAULIC PRESSURE & FLOW, HEAT, TYPE OF FLUID:** Any failure or performance deficiency attributable to excess hydraulic pressure, excess hydraulic back-pressure, excess hydraulic flow, excessive heat, or incorrect hydraulic fluid.

**REPAIRS OR ALTERATIONS:** Any failure or performance deficiency attributable to repairs by anyone which in Stanley's sole judgement caused or contributed to the failure or deficiency.

**MIS-APPLICATION:** Any failure or performance deficiency attributable to mis-application. "Mis-application" is defined as usage of products for which they were not originally intended or usage of products in such a manner which exposes them to abuse or accident, without first obtaining the written consent of Stanley. PERMISSION TO APPLY ANY PRODUCT FOR WHICH IT WAS NOT ORIGINALLY INTENDED CAN ONLY BE OBTAINED FROM STANLEY ENGINEERING.

**WARRANTY REGISTRATION:** STANLEY ASSUMES NO LIABILITY FOR WARRANTY CLAIMS SUBMITTED FOR WHICH NO TOOL REGISTRATION IS ON RECORD. In the event a warranty claim is submitted and no tool registration is on record, no warranty credit will be issued without first receiving documentation which proves the sale of the tool or the tools' first date of usage. The term "DOCUMENTATION" as used in this paragraph is defined as a bill of sale, or letter of intent from the first retail customer. A WARRANTY REGISTRATION FORM THAT IS NOT ALSO ON RECORD WITH STANLEY WILL NOT BE ACCEPTED AS "DOCUMENTATION".

## NO ADDITIONAL WARRANTIES OR REPRESENTATIONS

This limited warranty and the obligation of Stanley thereunder is in lieu of all other warranties, expressed or implied including merchantability or