

Please read and save this Repair Parts Manual. Read this manual and the General Operating Instructions carefully before attempting to assemble, install, operate or maintain the product described. Protect yourself and others by observing all safety information. The Safety Instructions are contained in the General Operating Instructions. Failure to comply with the safety instructions accompanying this product could result in personal injury and/or property damage! Retain instructions for future reference.

SHURflo Light-Duty Pedestal Rotary External Gear Pumps

Refer to form L-4082 for General Operating and Safety Instructions.

Description

SHURflo self-priming, positive displacement, external rotary gear pumps are ideal for a wide range of light-duty industrial, marine, agricultural, and commercial applications, providing a nearly pulseless flow and are designed specifically for reduced speed operations. Some models include an internal pressure relief valve. Limited self-priming capability on packing seal types. Pillow block shaft assembly is required when pulley driven. Motors are not included.

Uses: For use with non-particulate and non-abrasive fluids compatible with pump wet-end construction component materials.

- Flows to 24.8 GPM
- Max. RPM: 1725
- Max. PSI: 100
- Suction lift to 19.5 ft.
- Maximum viscosity of 100,000 SSU at reduced speed (max. input torque of 45 -160 in.-lbs.)
- Temperature ranges from -20 to 280° F
- Seals – Viton lip or Kevlar®/Teflon® packing type
- Bushings – Steel, bronze or carbon/graphite
- Maximum working pressure: 130 PSI
- Pumps can operate bi-directionally (reversible). In the opposite rotation, the pump pressure relief valve, if equipped, will not function.

BRONZE – Excellent for water-based fluids. Pumps have 303 stainless steel shafts. Models without zerks are available with or without internal pressure relief valves and include carbon graphite drive shaft bushings. Packing Kevlar®/Teflon® seal with temperature range of -20° to 210° F. Wet-end parts: Zerk models are constructed from stainless steel (17-7, 300 series and/or 18-8), bronze, brass, vellumoid, Kevlar®, and Teflon®. Non-zerk models are constructed from 303 stainless steel, bronze, brass, vellumoid, carbon, graphite, Kevlar®, and Teflon®. Models that include internal pressure relief valves also have stainless steel (17-7, 300 series and/or 18-8) wet-end components.

CAST IRON – Specifically designed for use with oil-based fluids. Not to be used with water-based fluids. Models without grease zerks include steel spur gears with steel shafts, cast iron shaft support, Viton® lip seals having a temperature range of 32° to 280° F. Wet-end parts are constructed from cast iron, stainless steel (17-7, 300 series and/or 18-8), steel, vellumoid, and Viton. Models with grease zerks include steel spur gears with steel shafts, cast iron shaft support, Kevlar®, and Teflon® packing seals having a temperature range of -20° to 210° F. Wet-end parts are constructed from cast iron, stainless steel (17-7, 300 series and/or 18-8), steel, vellumoid, Kevlar®, and Teflon®.

NOTE: Not for pulley drive systems without the use of a pillow block shaft assembly. See Rotary Gear Pump Selection Guide in the Motor Manual for suggestions concerning installation, selections, options, and accessories. For direct driving pumps, a coupler is required.

NOTE: Models with bearings and mechanical seal available as well as close-coupled.



WARNING: Do not use to pump flammable or explosive fluids such as gasoline, fuel oil, kerosene, etc. Do not use in flammable and/or explosive atmospheres. When pumping hazardous or dangerous materials, use only in a room or area designated for that purpose. For your protection, always wear proper clothing, eye protection, etc. in case of any malfunction. For proper handling techniques and cautions, contact your chemical supplier, insurance company and local agencies (fire dept., etc.). Failure to comply with this warning could result in personal injury and/or property damage.

SHURflo Light-Duty Pedestal Rotary External Gear Pumps

Performance

Bronze Models	Cast Iron Models	Port Size*	Max. Input Torque in.-lbs.	Pump RPM	Suction** Lift (ft)	GPM Pumping 10 Wt. Oil at 70° F (500 SSU)											
						Free Flow		25 PSI		50 PSI		75 PSI		100 PSI			
						GPM	HP	GPM	HP	GPM	HP	GPM	HP	GPM	HP		
B1	C1K	1/4	45	900	1.5	1.2	1/4	1.0	1/4	0.8	1/4	0.6	1/4	0.4	1/4		
BB1	C1V					1200	2.0	1.6	1/4	1.5	1/4	1.4	1/4	1.3	1/4	1.2	1/3
BBV1						1725	2.5	2.2	1/4	2.1	1/4	2.0	1/4	2.0	1/3	1.9	1/2
B2	C2K	1/4	45	900	1.5	2.5	1/4	2.5	1/4	2.4	1/4	2.3	1/3	2.1	1/4		
BB2	C2V					1200	2.2	3.3	1/4	3.3	1/4	3.2	1/4	3.1	1/3	2.9	1/3
BBV2						1725	3.5	4.8	1/3	4.8	1/3	4.7	1/2	4.6	1/2	4.4	3/4
B3	C3K	3/8	90	900	2.8	3.7	1/4	3.6	1/3	3.5	1/3	3.4	1/2	3.2	1/2		
BB3	C3V					1200	5.7	4.9	1/4	4.8	1/3	4.7	1/2	4.6	1/2	4.4	3/4
BBV3						1725	7.9	7.0	1/2	6.9	1/2	6.8	3/4	6.7	1	6.5	1
B4	C4K	1/2	90	900	5.1	5.6	1/3	5.5	1/3	5.4	1/2	5.3	3/4	5	1		
BB4	C4V					1200	6.7	7.5	1/3	7.4	1/2	7.3	3/4	7.2	1	6.9	1
BBV4						1725	12.3	10.8	1/2	10.7	3/4	10.6	3/4	10.5	1	10.2	1½
B5	C5K	3/4	160	900	6.6	10.8	1/2	10.6	3/4	10.5	3/4	10.4	1	10	1		
BB5	C5V					1200	9.3	14.3	1/2	14.2	3/4	14.1	1	13.9	1½	13.5	1½
BBV5						1725	15.2	20.6	3/4	20.5	1	20.3	1½	20.2	2	19.8	2
B6	C6K	1	160	900	8.1	12.6	1/2	12.5	3/4	12.3	1	12.1	1	11.7	1½		
BB6	C6V					1200	11.7	16.7	3/4	16.6	1	16.4	1½	16.2	1½	15.8	2
BBV6						1725	19.5	24.8	3/4	24.7	1	24.5	1½	24.3	2	23.9	3

Test data taken on SAE 10 wt. oil at 70° F (500 SSU).

Performance in water will decrease by about 10%, and HP required will also be reduced by 10%. (Don't use water with Cast Iron.)

Pump performance when pump is new. As pump wears, the performance will decrease.

(*) Female NPT inlet and outlet (in inches).

(**) Suction lift for packing seal models may be reduced based on packing tightness or viscosity; requires wetted gears and primed seal chamber.

NOTES: Max. PSI = 100 PSI

Max. RPM = 1725 RPM

Max. Input Torque = See chart above.

Pumps can operate bi-directionally (reversible). In the opposite rotation, the pump pressure relief valve, if equipped, will not function.

Consult tables in the Motor Manual L-4082 on HP adders and speed recommendations for high viscosity fluids.

Manufacturer reserves the right to change performance without notification.

Bronze Models B1 thru B6, BB1 thru BB6 and BBV1 thru BBV6 Cast Iron Models C1V thru C6V and C1K thru C6K

Specifications (Wet End)

Model	Port Size NPT*	Shaft Material	Casting Material	Gear Material	Bushing Material	Pressure Relief Valve**	Gasket Material	Packing/ Lip Seal***	Shipping Weight (lbs.)
Bronze Models									
B1†	1/4	303 SS	BR	BR	BR	NA	Vellumoid	Kevlar® Packing	3.5
BB1	1/4	304 SS	BR	BR	CG	NA	Vellumoid	Kevlar® Packing	3.4
BBV1	1/4	303 SS	BR	BR	CG	SS & BR	Vellumoid	Kevlar® Packing	3.6
B2†	1/4	303 SS	BR	BR	BR	NA	Vellumoid	Kevlar® Packing	5.4
BB2	1/4	303 SS	BR	BR	CG	NA	Vellumoid	Kevlar® Packing	5.2
BBV2	1/4	303 SS	BR	BR	CG	SS & BR	Vellumoid	Kevlar® Packing	5.7
B3†	3/8	303 SS	BR	BR	BR	NA	Vellumoid	Kevlar® Packing	9.1
BB3	3/8	303 SS	BR	BR	CG	NA	Vellumoid	Kevlar® Packing	6.3
BBV3	3/8	303 SS	BR	BR	CG	SS & BR	Vellumoid	Kevlar® Packing	6.8
B4†	1/2	303 SS	BR	BR	BR	NA	Vellumoid	Kevlar® Packing	7.2
BB4	1/2	303 SS	BR	BR	CG	NA	Vellumoid	Kevlar® Packing	7.0
BBV4	1/2	303 SS	BR	BR	CG	SS & BR	Vellumoid	Kevlar® Packing	7.4
B5†	3/4	303 SS	BR	BR	BR	NA	Vellumoid	Kevlar® Packing	9.4
BB5	3/4	303 SS	BR	BR	CG	NA	Vellumoid	Kevlar® Packing	9.0
BBV5	3/4	303 SS	BR	BR	CG	SS & BR	Vellumoid	Kevlar® Packing	10.2
B6†	1	303 SS	BR	BR	BR	NA	Vellumoid	Kevlar® Packing	10.3
BB6	1	303 SS	BR	BR	CG	NA	Vellumoid	Kevlar® Packing	9.9
BBV6	1	303 SS	BR	BR	CG	SS & BR	Vellumoid	Kevlar® Packing	11.1
Cast Iron Models									
C1V	1/4	CRS	CI	Steel	CI	NA	Vellumoid	Viton Lip Seal	2.8
C1K†	1/4	CRS	CI	Steel	CI	NA	Vellumoid	Kevlar® Packing	4.0
C2V	1/4	CRS	CI	Steel	CI	NA	Vellumoid	Viton Lip Seal	5.0
C2K†	1/4	CRS	CI	Steel	CI	NA	Vellumoid	Kevlar® Packing	4.9
C3V	3/8	CRS	CI	Steel	CI	NA	Vellumoid	Viton Lip Seal	5.7
C3K†	3/8	CRS	CI	Steel	CI	NA	Vellumoid	Kevlar® Packing	6.1
C4V	1/2	CRS	CI	Steel	CI	NA	Vellumoid	Viton Lip Seal	6.3
C4K†	1/2	CRS	CI	Steel	CI	NA	Vellumoid	Kevlar® Packing	6.5
C5V	3/4	CRS	CI	Steel	CI	NA	Vellumoid	Viton Lip Seal	8.2
C5K†	3/4	CRS	CI	Steel	CI	NA	Vellumoid	Kevlar® Packing	8.7
C6V	1	CRS	CI	Steel	CI	NA	Vellumoid	Viton Lip Seal	8.9
C6K†	1	CRS	CI	Steel	CI	NA	Vellumoid	Kevlar® Packing	9.2

CG = Carbon Graphite BR = Brass CI = Cast Iron CRS = Cold Rolled Steel SS = Stainless Steel

(†) These models have grease zerks that require frequent greasing.

(*) NPT inlet and outlet ports (in inches).

(**) Bronze models with pressure relief valves are made of stainless steel (17-7, 300 series and/or 18-8), and bronze and/or brass.

(***) Kevlar® packing is Teflon® impregnated. Viton lip seals have 300 series stainless steel case.

NOTE: Manufacturer reserves the right to change specifications without notification.

SHURflo Light-Duty Pedestal Rotary External Gear Pumps

Dimensions (inches)

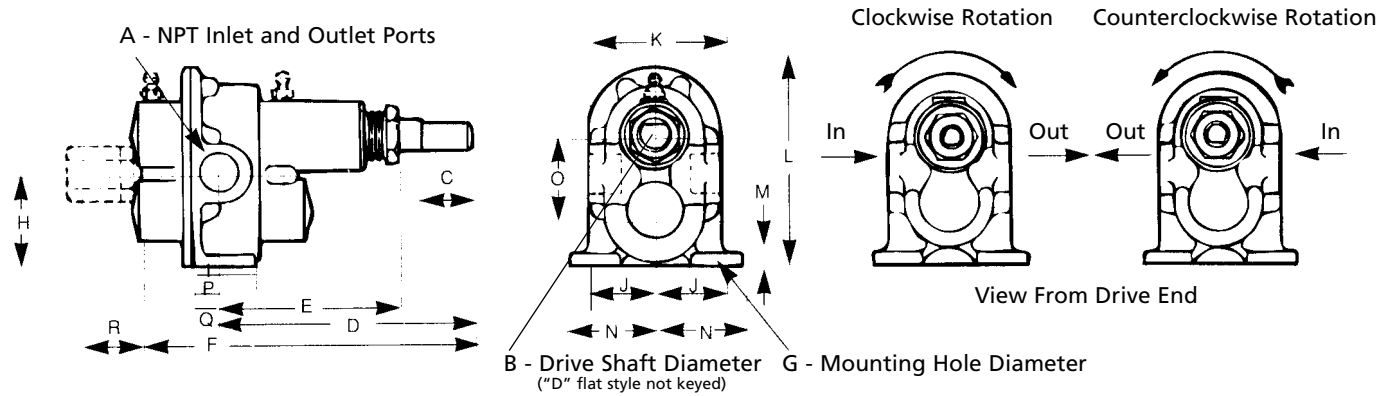

Figure 1

Bronze Models			Dimensions (in inches)																	
(1)	(2)	(3)	A	B	C	D	E	F	G	H	I	J	K	L	M	N	O	P	Q	R*
B1, BB1, BBV1			1/4	1/2	7/8	4	2 3/4	6	9/32	1 1/2	1 1/8	7/8	2 3/4	2 3/4	3/16	1 1/8	1 1/8	11/16	7/16	-
B2, BB2, BBV2			1/4	1/2	7/8	4 1/2	3 1/2	6 1/2	9/32	1 3/4	1 1/4	1 1/8	2 3/4	3 1/16	3/16	1 1/2	2 3/4	13/16	15/32	1 1/8
B3, BB3, BBV3			3/8	5/8	1	4 1/4	3 3/4	6 1/2	25/64	1 1/8	1 1/2	1 1/16	2 3/4	4	1/4	1 1/8	2 3/4	3/4	1/2	1 1/8
B4, BB4, BBV4			1/2	5/8	1	5 1/2	3 3/4	6 1/2	25/64	1 1/8	1 1/2	1 1/16	2 3/4	4	1/4	1 1/8	2 3/4	3/4	19/32	1 1/8
B5, BB5, BBV5			3/4	5/8	1	5	3 3/4	6 1/2	25/64	2 3/16	1 1/2	1 1/8	3 3/4	5 1/16	1/4	2	3 3/16	15/16	11/16	1 7/8
B6, BB6, BBV6			1	5/8	1	5 1/4	3 1/4	7 1/2	25/64	2 3/16	1 1/2	1 1/8	3 1/2	5 1/16	1/4	2	3 3/16	15/16	13/16	1 7/8

(*) Only applies to pumps with relief valves.

(1) Bronze grease zerks pumps, without pressure relief valve.

(2) Bronze pumps with carbon bushings, without pressure relief valve.

(3) Bronze pumps with carbon bushings and pressure relief valves.

NOTE: Dimensions have a tolerance of (+ or -) 1/8".

Manufacturer reserves the right to change dimensions without notification.

Bronze Models B1 thru B6, BB1 thru BB6 and BBV1 thru BBV6 Cast Iron Models C1V thru C6V and C1K thru C6K

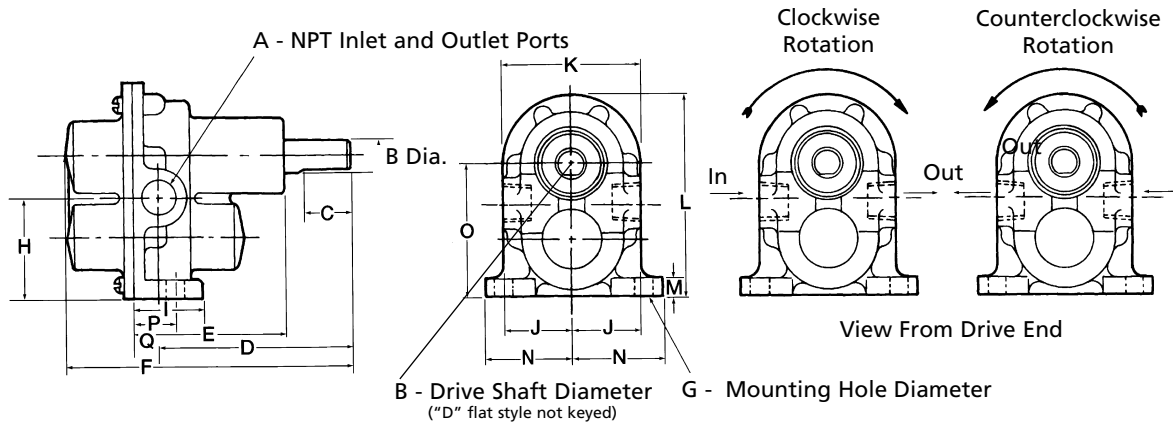

Figure 2

Cast Iron Models		Dimensions (in inches)																	
(1)	(2)	A	B	C	D	E	F	G	H	I	J	K	L	M	N	O	P	Q	
C1K, C1V		1/4	1/2	7/8	3 ³ / ₂	NA	4 ¹ / ₂	9/32	1 ¹³ / ₂	1 ¹ / ₈	7/8	2 ⁵ / ₁₆	2 ²³ / ₃₂	3/16	1 ¹³ / ₁₆	1 ¹ / ₈	11/16	13/32	
C2K, C2V		1/4	1/2	7/8	4 ¹³ / ₂	NA	6 ¹ / ₈	9/32	1 ²³ / ₂	1 ¹ / ₄	1 ¹ / ₈	2 ³ / ₈	3 ³ / ₁₆	1/4	1 ¹⁵ / ₂	2 ²³ / ₆₄	13/16	15/32	
C3K, C3V		3/8	5/8	1	4 ¹³ / ₂	NA	6 ³ / ₈	25/64	1 ¹ / ₈	1 ¹ / ₂	1 ¹ / ₁₆	2 ³ / ₄	4	5/16	1 ¹³ / ₁₆	2 ⁵ / ₈	3/4	9/16	
C4K, C4V		1/2	5/8	1	5 ⁵ / ₂	NA	7	25/64	1 ¹ / ₈	1 ¹ / ₂	1 ¹ / ₁₆	2 ³ / ₄	4	5/16	1 ¹³ / ₁₆	2 ⁵ / ₈	3/4	21/32	
C5K, C5V		3/4	5/8	1	4 ³ / ₂	NA	7	25/64	2 ³ / ₁₆	1 ¹ / ₂	1 ¹ / ₈	3 ³ / ₈	5 ¹³ / ₁₆	3/8	2	3 ³ / ₁₆	15/16	25/32	
C6K, C6V		1	5/8	1	5 ⁵ / ₂	NA	7 ¹ / ₄	25/64	2 ³ / ₁₆	1 ¹ / ₂	1 ¹ / ₈	3 ¹ / ₂	5 ¹³ / ₁₆	3/8	2	3 ³ / ₁₆	15/16	29/32	

(1) Cast Iron grease zerks pumps with packing seal, without pressure relief valve.

(2) Cast Iron pumps with lip seal, without pressure relief valve.

NOTE: Dimensions have a tolerance of (+ or -) 1/8".

Manufacturer reserves the right to change dimensions as required without notification.

SHURflo Light-Duty Pedestal Rotary External Gear Pumps

⚠ WARNING Check motor. It may be equipped with an automatic resetting thermal protector and may restart unexpectedly (see specifications chart). Protector tripping is an indication of motor overloading as a result of operating the pump at too high a pressure (over 100 PSI), too high of viscosity, too high of specific gravity, excessively high or low voltage, inadequate wiring, incorrect motor connections, too small a motor (sized incorrectly, not enough HP), or a defective motor or pump.

Do not handle pump with wet hands or when standing in water. Failure to follow the General Safety Information and all warnings could result in fatal electrical shock!

Installation

IMPORTANT: In any installations where property damage and/or personal injury can occur by pump not operating due to power outages, discharge line freezing, or any other reason, a backup system(s) and/or warning system(s) should be used.

1. Locate pump as close to the fluid source as possible, making the suction line as short and direct as possible.

NOTE: Unit should be placed where it is protected from the weather and extremes of heat, cold, and humidity.

2. Install pump mounting base on a flat, solid surface. Never operate pump unless it is rigidly secured to a solid foundation and properly aligned with the drive shaft. Shims may be provided with the pump to assist in aligning motor shaft to pump shaft.

NOTE: Pump misalignment is the greatest cause for gear and bearing wear and must be avoided. Many pump mountings act as noise amplifiers. A rubber pad under the pump base will help reduce the noise level.

3. Install a union, printing tee, and a gate valve (not furnished) on the discharge side of the pump for

service convenience. Since these are positive displacement pumps, the discharge line valve must be fully open during operation, otherwise motor overloading would occur.

PIPING

SUCTION

4. Avoid excessive lengths or number of fittings and bends in the suction line.
5. Attach suction line to suction inlet.
6. It is recommended that same size pipe as pump ports be used or, in cases requiring lengthy piping, the next larger size pipe be used.
7. If suction lift is greater than what is indicated in the performance chart, attach a foot valve below liquid level at end of suction line to ensure positive priming. Also note: If fluid specific gravity is greater than 1.4 or viscosity greater than 500 SSU, a foot valve is also recommended.
8. If solid contaminants are suspected in a liquid, place a filter in the suction line.
9. Be certain all suction piping connections are airtight.

NOTE: Assure airtight pipe connections with the use of a pipe joint sealant.

DISCHARGE

If a shut-off valve is required in the discharge line, consideration should be given to providing a pressure relief valve for the pump. Some models include a standard internal pressure relief valve located on the discharge side of the pump. If the pump does not have a pressure relief valve, it is recommended that an external pressure relief valve be installed for added pump protection.

⚠ CAUTION Shutting off the discharge without providing a pressure relief will cause extreme overpressures, resulting in pump

damage and/or motor failure. Globe valves or other restrictive valves should not be used as the shut-off mechanism as they are restrictive in nature and will size larger than suction piping. Do not exceed 100 PSI pump or system pressure.

Support pump and piping during assembly and after installation. Failure to do so may cause piping to break, pump to fail, motor bearing failures, etc., all of which can result in property damage and/or personal injury.

NOTE: Should the pump need to be self-draining, the pump head should be mounted in the vertical position with the suction port facing down. When pumping high viscosity fluids, the vertical position can be used with the suction port facing up and the pump mounted under the source. Increasing the suction pipe size and eliminating bends and elbows also assists in pumping high viscosity fluids. Max. viscosity is 500 SSU at 1725 RPM.

10. Operation under shut-off discharge conditions will overheat and damage pump. On pump models with pressure relief valves, do not exceed one minute of continuous relief. If extended periods of relief are anticipated, install a separate external pressure relief valve and pipe the relief leg of the valve either back to tank or well downstream from the pump suction.
11. Self-priming capabilities will vary depending on fluid viscosity, specific gravity and vapor pressure of the fluid. On pumps with packing, the suction lift is also influenced by the packing being too loose.
12. Adjust pressure at 5 PSI above the operating pressure in the discharge line with internal (on some models) or external pressure relief valve. The internal pressure relief valve is adjusted by removing the valve

Bronze Models B1 thru B6, BB1 thru BB6 and BBV1 thru BBV6 Cast Iron Models C1V thru C6V and C1K thru C6K

Installation (Continued)

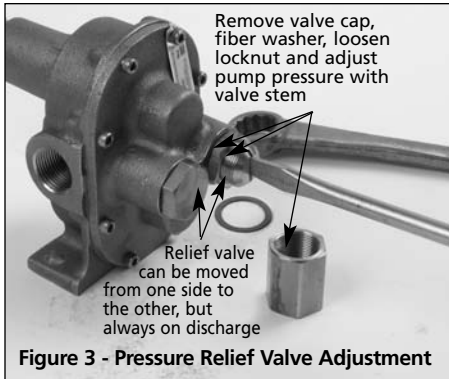

Figure 3 - Pressure Relief Valve Adjustment

cap, (Ref. No. 1, Figure 11 & Figure 3), loosening the valve locknut (Ref. No. 3) and using a flat tip screwdriver to adjust the valve stem (Ref. No. 2). Tightening the stem increases the pressure; loosening the stem decreases the pressure. The valve may leak during adjustment until the locknut is tightened and the valve cap and fiber washer are reinstalled.

The standard internal pressure relief valve must be located on the discharge side of the pump. The valve can be moved from one side to the other (See Figure 3). It is designed for internal relief only. Internal relief can be used for short periods of relief not to exceed one minute.

⚠ WARNING *Extended periods of internal relief can cause the pump to seriously overheat and cause severe internal damage to the pump components. If pump is reversed, pressure relief valve will not function.*

⚠ CAUTION *Do not exceed 100 PSI operating pressure.*

DRIVE CONNECTIONS

NOTE: Rotary gear pumps will operate equally well in either direction. When looking at the pump drive shaft end and rotating the shaft clockwise, the discharge port is on the right-hand

side. When turning counterclockwise, the discharge port is on the left-hand side. If equipped with pressure relief valve, the valve needs to be positioned on the discharge port.

DIRECT COUPLING DRIVES

Never use rigid coupling between the pump and motor. Some degree of flexibility must be allowed at the coupling to avoid excessive side loading of the motor and pump bearings. Any flexible

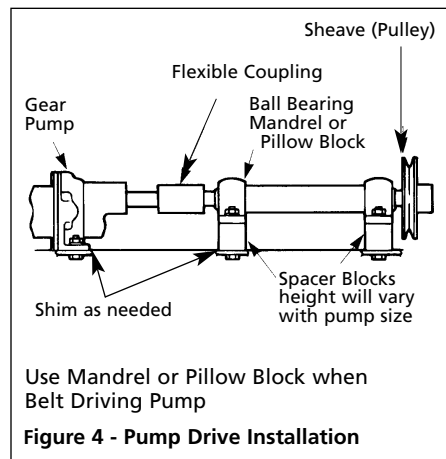

coupling rated for the horsepower load and speed is satisfactory. Care should be taken that the pump and motor shaft are in alignment. Misalignment will cause unnecessary loads on the pump and motor bearings (See Figure 4).

NOTE: Unit is not recommended for direct drive by engine (gas or diesel). If engine drive is desired or reduced pump speed is required, a "V" belt arrangement is recommended to reduce drive shaft side torque loads on the pump. Maximum RPM is 1725.

SHIMS & DIRECT MOUNTING OF PUMP

The direct coupling of the pumps to motors is accomplished through the accurate alignment of the pump shaft to the motor shaft. Specifications for flexible couplings are typically 1° angular misalignment and .015" of parallel

misalignment. Shims are provided to adjust pump and/or motor heights during direct coupling of pump to motor.

NOTE: These shims are not pump parts.

None, some, or all may be used according to variations in shaft heights. Pump and motor should be mounted on a flat base to ensure parallel alignment. The height alignment is attained through the use of the large spacers under either the motor or the pump as required (See Figure 4). Thin shims are provided for final adjustment. A straight edge should be placed across both couplings to check for horizontal and vertical misalignment. Horizontal misalignment is corrected by loosening either or both the pump and motor and sliding until alignment is achieved. Final vertical alignment is achieved through the use of the .005" and .010" thick shims for variations in motor or pump shaft heights (See Figure 4).

⚠ WARNING *Failure to accurately align pump to motor can result in noisy operation, reduced pump and motor life, and leaking pump. Misalignment must be corrected.*

PULLEY DRIVE

In some cases, a reduction in pump speed is essential. This may be accomplished through a belt and pulley. Bear in mind, however, that the belt tension adds a side thrust to the pump drive shaft which results in extra bearing loading and wear with resulting shortened pump life. A ball bearing pillow block to support the belt load is advisable (See Figure 4).

For pulley-driven pumps, a single "V" belt is necessary up to 1 HP, 3450 RPM. For larger drive sizes, double "V" belts are recommended. Maximum pump RPM is 1725. Install safety guard, shield, etc. around all moving parts and electrical components.

SHURflo Light-Duty Pedestal Rotary External Gear Pumps

Installation (Continued)

▲ WARNING *Failure to install proper safety guard, shield, etc. can result in property damage and/or personal injury. Follow all electrical and safety codes, as well as National Electric Code (NEC) and Occupational Safety and Health Act (OSHA) in the United States.*

13. When using an electric motor, make necessary electrical connections for the voltage outlet supply and double-check all connections. Check power connections for proper voltage. (Refer to wiring diagram on motor nameplate or inside the terminal box for the proper connections.) See General Safety Information.

IMPORTANT: Electrical circuit must be properly fused.

If using a gasoline engine, fill engine with gas and oil before starting. See General Safety Information.

▲ WARNING *Gasoline is a highly combustible fuel. Improper use, handling, or storage of gasoline can be dangerous. Never fill or touch a hot engine.*

14. Unit is ready for operation.

Operation

▲ CAUTION *Do not run pump dry. Permanent damage to the pump seals, bearings and gears will result. Suction pressure should never be greater than the discharge pressure.*

1. The self-priming pump must have the gears and seal wetted before it is started.
2. Fill pump with liquid to be pumped through priming tee (if installed) or remove discharge piping and fill. A new primed pump (suction line and pump full of liquid) is capable of up to 19.5 foot vertical or horizontal lift, depending on pump model. (Refer to performance chart for actual suction lift values.)
3. Once pump is full, replace the priming plug or reconnect discharge line and unit is ready to run.

▲ CAUTION *Pump models equipped with a packing-type seal are preset at the factory, but should be checked on initial pump start-up. The packing rings should be not too tight or too loose. Seal should be tightened to drip 10 drops every 3 to 5 minutes. Too tight will cause excess drag and heat, reducing seal life. Too loose will reduce suction lift capability and cause excess leaking.*

NOTE: If foot valve (or check valve) is not used in suction line, it may be necessary to refill the pump every time the unit is stopped and you wish to restart the pump. This all depends on the length of time between starts and whether or not the gears are wet enough to close cavities to effect a prime. Suction pressure should never be greater than the discharge pressure.

For long life, prime pump before start-up. Care should be taken at all times to avoid dry running as this will cause increased wear of the gears, seal and bearings; reduced pump performance; and shortened pump life. Gear pumps are built to very close tolerance and this tolerance must not be disturbed. The liquids must, therefore, be free of all abrasives. Sand, silt, wettable powders, etc. must be avoided.

4. Pumps equipped with grease zerks should be greased prior to operation.

Maintenance

▲ WARNING *Make certain that the power source is disconnected before attempting to service or disassemble any components! If the power disconnect is out of sight, lock it in the open position and tag to prevent application of power.*

1. On pump models with packing-type seals, the packing nut must be periodically checked and adjusted to drip 10 drops every 3 to 5 minutes. Failure to do so can result in excessive leakage as the packing wears out.

2. On pump models with grease fittings, the units should be lubricated with grease frequently.
3. Lip seal models require no particular maintenance but should be checked for leaks and performance.

CLEANING

Clean the suction line filter at regular intervals.

ELECTRICAL MOTOR

Periodically clean dirt accumulations from open-type motors, especially in and around vent openings, preferably by vacuuming (avoids imbedding dirt in windings). Oil and maintain as recommended by the motor manufacturer. Properly selected and installed electric motors are capable of operating for years with minimal maintenance.

GENERAL

1. Check pump daily, weekly, monthly, etc. for proper operation. If anything has changed since unit was new, unit should be removed and repaired or replaced. Only qualified electricians or service technicians should attempt to repair this unit. Improper repair and/or assembly can cause an electric shock hazard.
2. Check the pump to motor shaft alignment at regular intervals.
3. Pump should be drained if placed in an area that is subject to freezing temperatures. If the pump is to be stored, place a small quantity of light oil or some other storage preservative compatible with your application in the pump and rotate the shaft very slowly to work the oil throughout the gears and the body.

NOTE: Cast Iron models are not recommended for water-based fluids.

4. Periodically check piping and/or hoses for good connections and excessive wear, etc. Replace parts or pump as needed.

Bronze Models B1 thru B6, BB1 thru BB6 and BBV1 thru BBV6 Cast Iron Models C1V thru C6V and C1K thru C6K

Disassembly & Assembly

SEAL REPLACEMENT - PACKING TYPE

Refer to Figures 9-11 on pages 10-12.

1. On pumps equipped with packing seals, if the packing drips excessively and the packing nut cannot be adjusted further, then either the packing or the pump shaft needs to be replaced. To replace packing, remove the pump from its application, then remove packing nut (Ref. No. 10 or Ref. No. 16 for relief valve pumps). Remove the worn-out packing rings (the set of three or four rings). They can be picked from the bore, or remove the cover and the drive gear and shaft assembly. Remove the old packing rings (See Figure 5). The drive shaft and gear assembly should be inspected when the pump is apart. Excessive wear on the shaft in the packing area or excessive wear in the gear pocket is cause to replace the pump. These series of pumps are throw-away type.



Figure 5 - Packing Seal Replacement

2. Most pumps require either three or four packing rings (Ref. No. 9 or Ref. No. 15 for relief valve pumps). The split in the packing rings should be staggered to ensure good sealing of

the pump. Wet packing rings with water for bronze models and with oil for cast iron models, prior to install. Gently tap each ring in place using a piece of plastic pipe (See Figure 6).



Figure 6 - Packing Installation

3. Install packing nut and tighten lightly (See Figure 7).
4. Reinstall pump and all safety shields, and prime the pump wetting gears and seal.
5. Start pump and adjust packing nut so packing seal drips 10 drops every 3 to 5 minutes (See Figure 7).

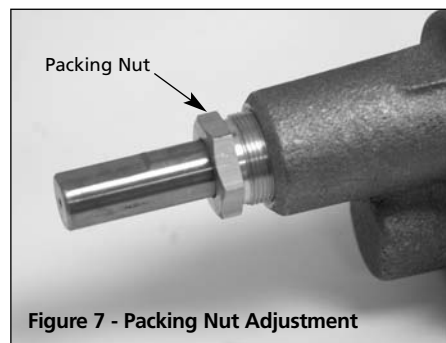

Figure 7 - Packing Nut Adjustment

SEAL REPLACEMENT - LIP SEAL TYPE

Refer to Figure 12 on page 14.

1. On pumps equipped with lip seal, remove pump from application and disassemble.
2. Remove retaining ring (Ref. No. 1). Pry out old lip seal (Ref. No. 8). This can be done externally or by splitting the pump and removing the drive shaft assembly and pushing the seal out from the inside.
3. Install new lip seal by pushing new seal into drive shaft housing with a wood dowel or socket, flush to the machined lip on the pump housing. Replace retaining ring (See Figure 8).

NOTE: Lubricate seal with oil prior to install and inspect pump drive shaft for scratches or burrs before final assembly.

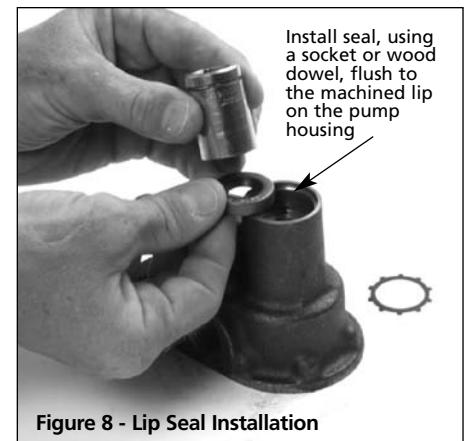

Figure 8 - Lip Seal Installation

4. Reassemble pump. Excessive wear on the shaft in the seal area or excessive wear in the gear pocket is cause to replace the pump. These series of pumps are throw-away type.
5. Reinstall pump and all safety shields. Prime the pump, wetting gears and seal, prior to operation.

To order parts, contact a SHURflo Distributor or Order Direct.
Distributors can be found at www.shurfloindustrial.com.

Please provide following information:

- Model number
- Serial number (if any)
- Part description and number as shown in parts list

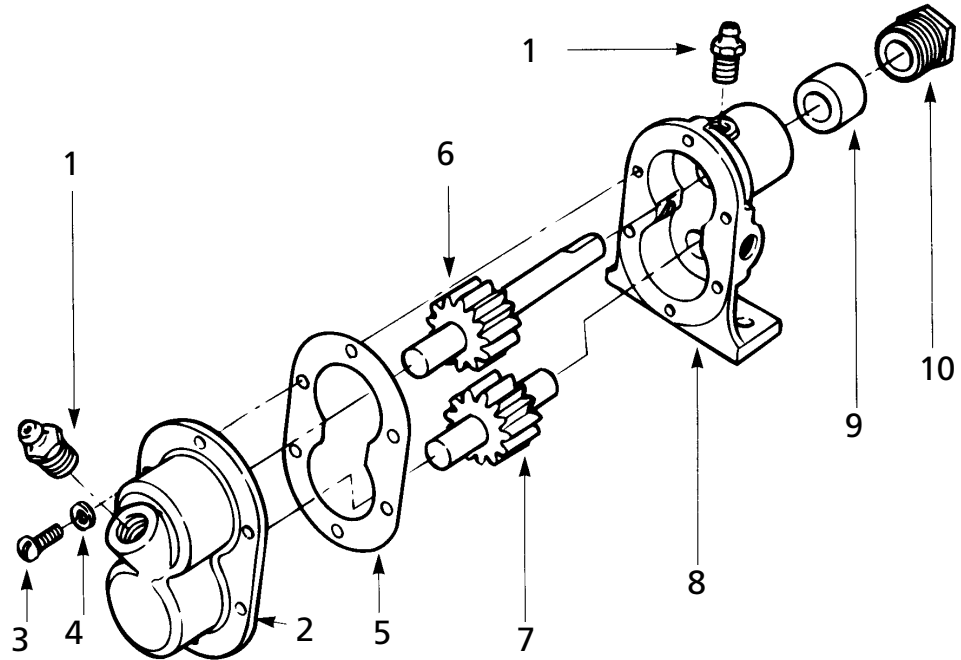

Figure 9 – Repair Parts Illustration

Repair Parts List for Bronze Models With Grease Zerk Fittings – Models B1 thru B6

Ref. No.	Description	Model B1		Model B2		Model B3		Model B4		Model B5		Model B6	
		Part No.	Qty.	Part No.	Qty.	Part No.	Qty.	Part No.	Qty.	Part No.	Qty.	Part No.	Qty.
1	Grease zerk fitting	NA	2	NA	2	NA	2	NA	2	NA	2	NA	2
2	Cover (BZ)	NA	1	NA	1	NA	1	NA	1	NA	1	NA	1
3	Machine screw	NA	6	NA	7	NA	8	NA	8	NA	8	NA	8
4	Lockwasher	NA	6	NA	7	NA	8	NA	8	NA	8	NA	8
5	Gasket (vellumoid)	18990	1	09878	1	00252	1	00252	1	05486	1	05486	1
6	Drive gear/ shaft Assy.	NA	1	NA	1	NA	1	NA	1	NA	1	NA	1
7	Driven gear/ shaft Assy.	NA	1	NA	1	NA	1	NA	1	NA	1	NA	1
8	Body (BZ)	NA	1	NA	1	NA	1	NA	1	NA	1	NA	1
9	Kevlar®/Teflon® packing (set of 3 or 4 rings)	18996P	1	11693P	1	11694P	1	11694P	1	11694P	1	11694P	1
10	Packing nut	18997	1	11524	1	11525	1	11525	1	11525	1	11525	1

BZ = Bronze

To order parts, contact a SHURflo Distributor or Order Direct.
Distributors can be found at www.shurfloindustrial.com.

Please provide following information:

- Model number
- Serial number (if any)
- Part description and number as shown in parts list

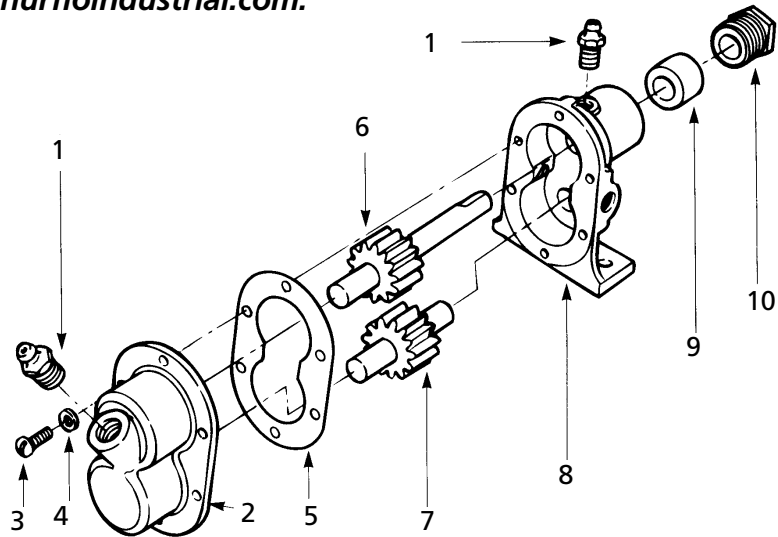

Figure 10 – Repair Parts Illustration

Repair Parts List for Cast Iron Models With Kevlar Packing – Models C1K thru C6K

Ref. No.	Description	Model C1K		Model C2K		Model C3K		Model C4K		Model C5K		Model C6K	
		Part No.	Qty.	Part No.	Qty.	Part No.	Qty.	Part No.	Qty.	Part No.	Qty.	Part No.	Qty.
1	Grease zerk fitting	NA	1	NA	2	NA	2	NA	2	NA	2	NA	2
2	Cover (CI)	NA	1	NA	1	NA	1	NA	1	NA	1	NA	1
3	Machine screw	NA	6	NA	7	NA	8	NA	8	NA	8	NA	8
4	Lockwasher	NA	6	NA	6	NA	7	NA	8	NA	8	NA	8
5	Gasket (vellumoid)	18990	1	13350	1	12786	1	12786	1	13351	1	13351	1
6	Drive gear & shaft	NA	1	NA	1	NA	1	NA	1	NA	1	NA	1
7	Driven gear & shaft	NA	1	NA	1	NA	1	NA	1	NA	1	NA	1
8	Body (CI)	NA	1	NA	1	NA	1	NA	1	NA	1	NA	1
9	Kevlar®/Teflon® packing (set of 3 or 4 rings)	18996P	1	11693P	1	11694P	1	11694P	1	11694P	1	11694P	1
10	Packing nut	18997	1	11524	1	11525	1	11525	1	11525	1	11525	1

CI = Cast Iron

Repair Parts List for Bronze Models with Carbon-Graphite Bushings – Models BB1 thru BB6

Ref. No.	Description	Model BB1		Model BB2		Model BB3		Model BB4		Model BB5		Model BB6	
		Part No.	Qty.	Part No.	Qty.	Part No.	Qty.	Part No.	Qty.	Part No.	Qty.	Part No.	Qty.
1	Not part of Pump												
2	Cover assembly (BZ)	NA	1	NA	1	NA	1	NA	1	NA	1	NA	1
3	Machine screw	NA	4	NA	7	NA	8	NA	8	NA	8	NA	8
4	Lockwasher	NA	6	NA	7	NA	8	NA	8	NA	8	NA	8
5	Gasket (vellumoid)	18990	1	09878	1	00252	1	00252	1	05486	1	05486	1
6	Drive gear/shaft Assy.	NA	1	NA	1	NA	1	NA	1	NA	1	NA	1
7	Driven gear/shaft Assy.	NA	1	NA	1	NA	1	NA	1	NA	1	NA	1
8	Body assembly (BZ)	NA	1	NA	1	NA	1	NA	1	NA	1	NA	1
9	Kevlar®/Teflon® packing (set of 3 or 4 rings)	18996P	1	11693P	1	11694P	1	11694P	1	11694P	1	11694P	1
10	Packing nut	18997	1	11524	1	11525	1	11525	1	11525	1	11525	1
†	CG bushings	NA	4	NA	1	NA	1	NA	1	NA	1	NA	1
†	CG bushings			NA	3	NA	3	NA	3	NA	3	NA	3

BZ = Bronze CI = Cast Iron CG = Carbon Graphite

(†) Carbon-graphite bushings are not shown in illustration, but four are required for each pump equipped with them. In most cases, the drive bushing is a different part number from the other three. Bushings are not available; usually when they need to be replaced, the whole pump needs to be replaced.

To order parts, contact a SHURflo Distributor or Order Direct.
Distributors can be found at www.shurfloindustrial.com.

Please provide following information:

- Model number
- Serial number (if any)
- Part description and number as shown in parts list

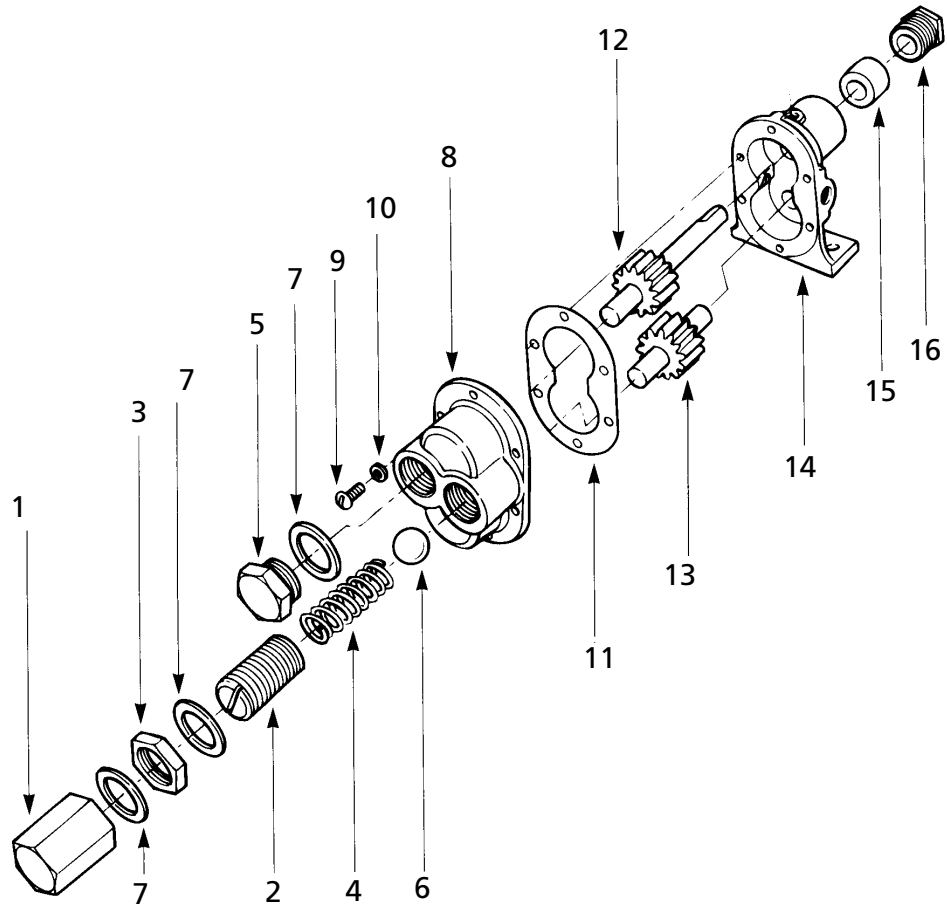

Figure 11 – Repair Parts Illustration

Repair Parts List for Bronze Models with Carbon-Graphite Bushings and Relief Valve – Models BBV1 thru BBV6

Ref. No.	Description	Model BBV1		Model BBV2		Model BBV3		Model BBV4		Model BBV5		Model BBV6	
		Part No.	Qty.	Part No.	No.	Part No.	Qty.	No.	Part No.	Qty.	No.	Part No.	Qty.
1	Valve cap (brass)	NA	1	NA	1	NA	1	NA	1	NA	1	NA	1
2	Valve stem (brass)	NA	1	NA	1	NA	1	NA	1	NA	1	NA	1
3	Valve locknut	NA	1	NA	1	NA	1	NA	1	NA	1	NA	1
4	Valve spring (17-7 SS)	NA	1	NA	1	NA	1	NA	1	NA	1	NA	1
5	Hex plug	NA	1	NA	1	NA	1	NA	1	NA	1	NA	1
6	Ball (300 Series SS)	NA	1	NA	1	NA	1	NA	1	NA	1	NA	1
7	Valve gasket	11582		11582	1	11582	1	11582	1	11583	1	11583	1
8	Cover assembly (BZ)	NA	1	NA	1	NA	1	NA	1	NA	1	NA	1
9	Machine screw	NA	8	NA	8	NA	8	NA	8	NA	8	NA	8
10	Lockwasher	NA	7	NA	7	NA	8	NA	8	NA	8	NA	8
11	Gasket (vellumoid)	09878	1	09878	1	00252	1	00252	1	05486	1	05486	1
12	Drive gear/shaft Assy.	NA	1	NA	1	NA	1	NA	1	NA	1	NA	1
13	Driven gear/shaft Assy.	NA	1	NA	1	NA	1	NA	1	NA	1	NA	1
14	Body assembly (BZ)	NA	1	NA	1	NA	1	NA	1	NA	1	NA	1
15	Kevlar®/Teflon® packing (set of 3 or 4 rings)	11693P	1	11693P	1	11694P	1	11694P	1	11694P	1	11694P	1
16	Packing nut	11524		11524	1	11525	1	11525	1	11525	1	11525	1
†	CG Bushings	NA	3	NA	3	NA	3	NA	3	NA	3	NA	3
†	CG Bushings	NA	1	NA	1	NA	1	NA	1	NA	1	NA	1

BZ = Bronze CI = Cast Iron CG = Carbon Graphite SS = Stainless Steel

(†) Carbon-graphite bushings are not shown in illustration, but four are required for each pump equipped with them. In most cases, the drive bushing is a different part number from the other three. Bushings are not available; usually when they need to be replaced, the whole pump needs to be replaced.

To order parts, contact a SHURflo Distributor or Order Direct.
Distributors can be found at www.shurfloindustrial.com.

Please provide following information:

- Model number
- Serial number (if any)
- Part description and number as shown in parts list

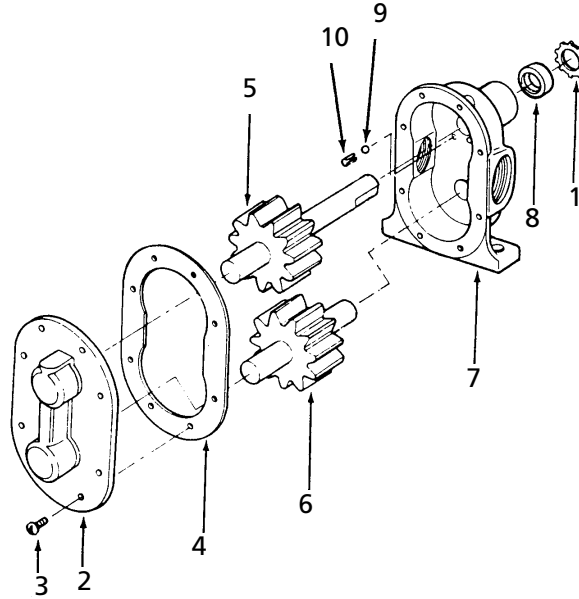

Figure 12 – Repair Parts Illustration

Repair Parts List for Cast Iron Models With Viton Lip Seal – Models C1V thru C6V

Ref. No.	Description	Part No. For Model:						Qty.
		C1V	C2V	C3V	C4V	C5V	C6V	
1	Retaining ring	14996	13353	13354	13354	13354	13354	1
2	Cover (CI)	NA	NA	NA	NA	NA	NA	1
3	Machine screw	12686	12686	12686	12686	12686	12686	8
4	Gasket (vellumoid)	18990	13350	12786	12786	13351	13351	1
5	Drive Gear & Shaft Assy.	NA	NA	NA	NA	NA	NA	1
6	Driven Gear & Shaft Assy.	NA	NA	NA	NA	NA	NA	1
7	Body (CI)	NA	NA	NA	NA	NA	NA	1
8	Lip seal, Viton	11674	11674	2107-0002	2107-0002	2107-0002	2107-0002	1
	Lip seal, Buna-N (optional)	19205	19205	10514C	10514C	10514C	10514C	1
9	Ball (reverse rotation pressure stabilizer)	NA	NA	NA	NA	NA	NA	1
10	Retainer Pin	NA	NA	NA	NA	NA	NA	1

CI = Cast Iron

Limited Warranty on SHURflo Light-Duty Pedestal Rotary External Gear Pumps

SHURflo warrants to the original purchaser of its products (the "Purchaser") that such products will be free from defects in material and workmanship under normal use for the period of six (6) months, and accessories will be free from defects in material and workmanship under normal use for the period of ninety (90) days.

"Normal use" does not include use in excess of recommended maximum speeds, pressures, vacuums and temperatures, or use requiring handling of fluids not compatible with component materials. This warranty does not cover freight damage, freezing damage, normal wear and tear, or damage caused by misapplication, fault, negligence, alterations, or repair that affects the performance or reliability of the product.

THIS WARRANTY IS EXCLUSIVE. SHURflo MAKES NO OTHER WARRANTY, EXPRESS OR IMPLIED, INCLUDING BUT NOT LIMITED TO ANY WARRANTY OF MERCHANTABILITY OR FITNESS FOR A PARTICULAR PURPOSE.

SHURflo's obligation under this warranty is, at SHURflo's option, to either repair or replace the product upon return of the entire product to the SHURflo factory in accordance with the return procedures set forth below. **THIS IS THE EXCLUSIVE REMEDY FOR ANY BREACH OF WARRANTY.**

IN NO EVENT SHALL SHURflo BE LIABLE FOR ANY INCIDENTAL OR CONSEQUENTIAL DAMAGES OF ANY KIND, WHETHER FOR BREACH OF ANY WARRANTY, FOR NEGLIGENCE, ON THE BASIS OF STRICT LIABILITY, OR OTHERWISE.

Only authorized distributors can return products for Warranty. Contact your distributor or visit www.shurfloindustrial.com to find a distributor for product support.

Distributors can obtain an RMA # and contact person's name by contacting SHURflo's customer service at 800-854-3218 (Ext. 6788 or Ext. 6651).

Return Procedures for Distributors

All pumps or products must be flushed of any chemical (ref. OSHA Section 0910.1200 (d)(e)(f)(g)(h) and hazardous chemicals must be labeled before being shipped* to SHURflo for service or warranty consideration. SHURflo reserves the right to request a Material Safety Data sheet from the Purchaser for any pump or product SHURflo deems necessary. SHURflo reserves the right to "disposition as scrap" pumps or products returned which contain unknown substances, or to charge for any and all costs incurred for chemical testing and proper disposal of components containing unknown substances. SHURflo requests this in order to protect the environment and personnel from the hazards of handling unknown substances.

Be prepared to give SHURflo full details of the problem, including the following information:

1. Model number, purchase date and from whom you purchased your pump.

2. A brief description of the pump problem, including the following:

- Liquid pumped. State the pH and any non-soluble materials, and give the generic or trade name.
- Temperature of the liquid and ambient environment.
- Suction lift or vacuum (measured at the pump).
- Discharge pressure.
- Size, type, and mesh of the suction strainer.
- Drive type (gas engine/electric motor; direct/belt drive; tractor PTO) and rpm of pump.
- Viscosity (of oil, or other than water weight liquid).
- Elevation from the pump to the discharge point.
- Size and material of suction and discharge line.

SHURflo may request additional information, and may require a sketch to illustrate the problem. Distributors should contact the factory to receive a return material authorization before sending the product. All pumps returned for warranty work should be sent shipping charges prepaid to:

[RMA# and Contact Person]
SHURflo
375 Fifth Avenue NW
New Brighton, Minnesota 55112

*Carriers, including U.S.P.S., airlines, UPS, ground freight, etc., require specific identification of any hazardous materials being shipped. Failure to do so may result in a substantial fine and/or prison term. Check with your shipping company for specific instructions.

