Models 3U / 3UB

End Suction Centrifugal



Operating Instructions, Installation & Maintenance Manual



EBARA Fluid Handling

EBARA International Corporation

Operating, Installation, and Maintenance**Contents**

Section	Page
Safety Specifications and Installation	3
3U / 3UB Selection Chart	5
3U / 3UB Specifications	6
3U / 3UB Type 1 Sectional View and Parts List	7
3U(B) 65 Type 3 Sectional View and Parts List	8
Installation Instructions	9
Maintenance and Service	10
3U / 3UB Assembly – 3HP - 15HP	11
3U / 3UB Assembly – 20HP - 30HP	12
Troubleshooting Checklist and Maintenance Information	13

**WARNING****IMPORTANT SAFETY INSTRUCTIONS****Rules for Safe Installation and Operation**

1. Read these rules and instructions carefully. Failure to follow them could cause serious bodily injury and/or property damage.
2. Check your local codes before installing. You must comply with their rules.
3. For maximum safety, this product should be connected to a grounded circuit equipped with a ground fault interrupter device.
4. Before installing this product, have the electrical circuit checked by an electrician to make sure it is properly grounded.
5. Before installing or servicing your pump, BE CERTAIN pump power source is disconnected.
6. Make sure the line voltage and frequency of the electrical current supply agrees with the motor wiring. If motor is dual voltage type, BE SURE it is wired correctly for your power supply.
7. Complete pump and piping system MUST be protected against below freezing temperature. Failure to do so could cause severe damage and voids the Warranty.
8. Avoid system pressures that may exceed one and a half times the operating point selected from the pump performance curve.
9. Do not run your pump dry. If it is, there will be damage to the pump seal.

Installation**PACKAGE CONTENTS**

1. Be sure all parts have been furnished and that nothing has been damaged in shipment.
2. The catalog lists all parts included with package. A packing list packed with pump, also lists contents.
3. OPEN PACKAGES AND MAKE THIS CHECK BEFORE GOING ON JOB.

PIPING – Pipes must line up and not be forced into position by unions. Piping should be independently supported near the pump so that no strain will be placed on the pump casing. Where any noise is objectionable, pump should be insulated from the piping with rubber connections. Always keep pipe size as large as possible and use a minimum of fittings to reduce friction losses.

SUCTION PIPING – Suction pipe should be direct and as short as possible. It should be at least one size larger than suction inlet tapping and should have a minimum of elbows and fittings (5 to 6 pipe diameters of straight pipe before inlet is recommended). The piping should be laid out so that it slopes upward to pump without dips or high points so that air pockets are eliminated. The highest point in the suction piping should be the pump inlet except where liquid flows to the pump inlet under pressure.

The suction pipe must be tight and free of air leaks or pump will not operate properly.

Operating, Installation, and Maintenance

Rules for Safe Installation and Operation (continued)

DISCHARGE PIPING – Discharge piping should never be smaller than pump tapping and should preferably be one size larger. A gate valve should always be installed in discharge line for throttling if capacity is not correct. To protect the pump from water hammer and to prevent backflow, a check valve should be installed in the discharge line between the pump and gate valve.

ELECTRICAL CONNECTIONS – Be sure motor wiring is connected for voltage being used. Unit should be connected to a separate circuit. A fused disconnect switch or circuit breaker must be used in this circuit. Wire of sufficient size should be used to keep voltage drop to a maximum of 5%.

Single phase motors have built-in overload protection. Flexible metallic conduit should be used to protect the motor leads.

PRIMING – The pump must be primed before starting. The pump casing and suction piping must be filled with water before starting motor. When water is poured into pump to prime, remove all air before starting motor.

STARTING – When the pump is up to operating speed, open the discharge valve to obtain desired capacity or pressure. Do not allow the pump to run for long periods with the discharge valve tightly closed. If the pump runs for an extended period of time without liquid being discharged, the liquid in the pump case can get extremely hot.

ROTATION – All single phase motors are single rotation and leave factory with proper rotation. Three phase motors should be checked to ensure proper rotation

FREEZING – Care should be taken to prevent the pump from freezing during cold weather. It may be necessary, when there is any possibility of this, to drain the pump casing when not in operation. Drain by removing the pipe plug in the bottom of the casing.

ROTARY SEAL – PRO STEEL pumps are fitted only with rotary seal. This seal is recommended for LIQUIDS free from abrasives.

LOCATION OF UNIT – The pump should be installed as near to the liquid source as is practical so that the static suction head (vertical distance from the center line of the pump to water level) is maximized, and so that a short, direct suction pipe may be used. The capacity of a centrifugal pump is reduced when the unit is operated under a high suction lift. The piping should be as free from turns and bends as possible, as elbows and fittings greatly increase friction loss. Place the unit so that it is readily accessible for service and maintenance and on a solid foundation, which provides a rigid and vibration-free support. Protect the pump against flooding and excess moisture.



Model 3U / 3UB Selection chart

Synchronous Speed 3450 RPM

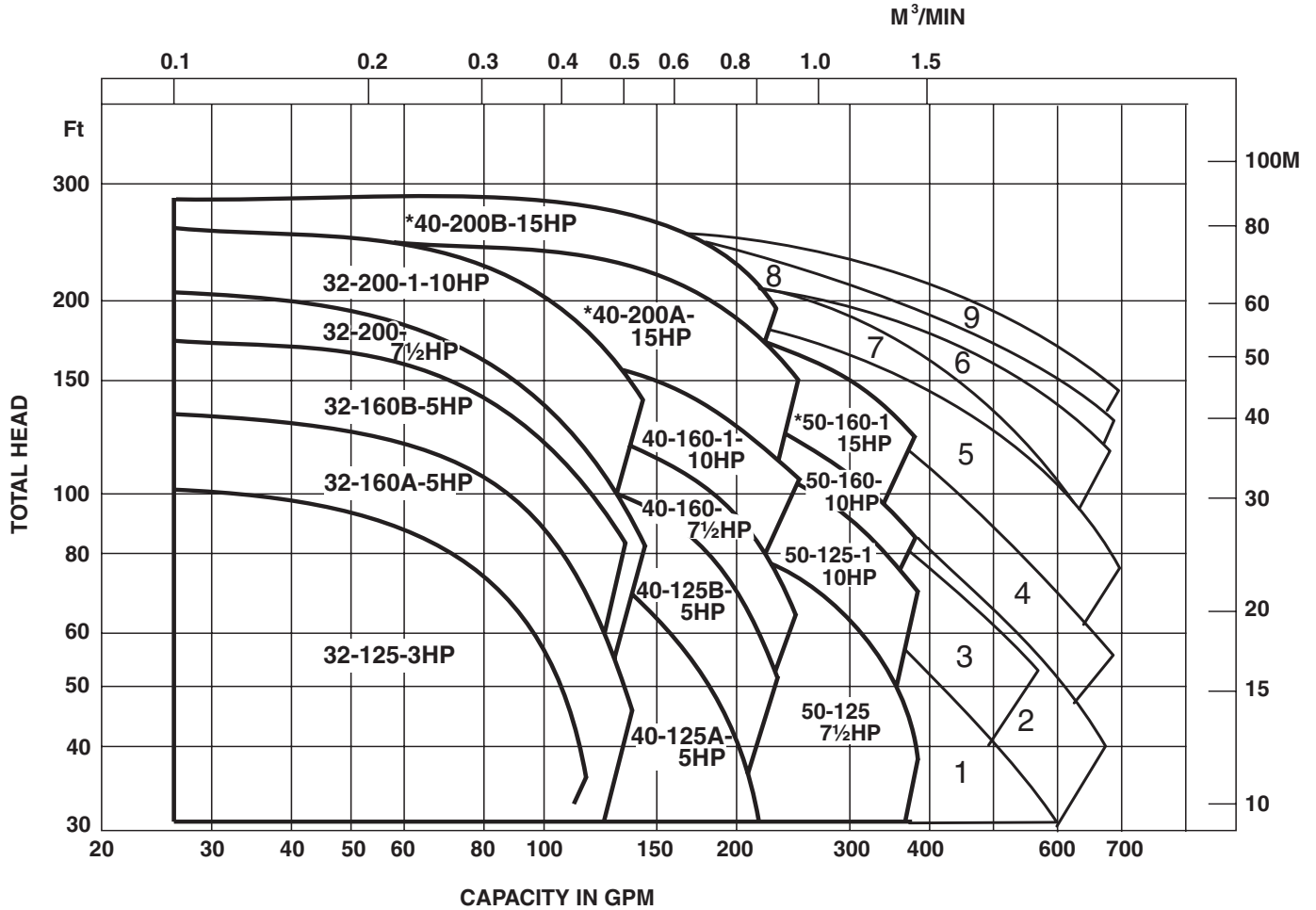

***Three phase motor only**

- 1. 3U65-125-7.5HP
- 2. 3U65-125-10HP
- 3. 3U65-160-10HP
- 4. 3U65-160-15HP*
- 5. 3U65-160-20HP*
- 6. 3U65-160-25HP*
- 7. 3U65-200-20HP*
- 8. 3U65-200-25HP*
- 9. 3U65-200-30HP*

Operating, Installation, and Maintenance

Specifications

	Standard	Optional										
Size Suction (150 lb. ANSI R.F. equivalent) Discharge (150 lb. ANSI R.F. equivalent)	3U32 – 2" ANSI Equivalent 3U40 – 2½" ANSI Equivalent 3U50 – 2½" ANSI Equivalent 3UB65 – 3" ANSI Equivalent 3U32 – 1¼" ANSI Equivalent 3U40 – 1½" ANSI Equivalent 3U50 – 2" ANSI Equivalent 3UB65 – 2½" ANSI Equivalent	Companion Flange kit 150 Lb. ANSI, Female NPT										
Range of HP	3U – 3 HP to 15 HP 3UB – 7½ HP to 30 HP											
Range of Performance Capacity Head	13 to 750 GPM at 3450 RPM 33 to 250 feet at 3450 RPM											
Liquid handled Type of liquid Temperature Max. working pressure	Clean water 212°F (100°C) 230 PSI (15 Bar)	Max. 250°F (121°C) with optional high temperature seal										
Materials Casing Impeller (closed type) Shaft Sleeve Bracket	<table border="0"> <tr> <td>3U</td> <td>3UB</td> </tr> <tr> <td>304L Stainless Steel</td> <td>304L Stainless Steel</td> </tr> <tr> <td>304L Stainless Steel</td> <td>Bronze</td> </tr> <tr> <td>304L Stainless Steel</td> <td>304L Stainless Steel</td> </tr> <tr> <td>Cast iron</td> <td>Cast iron</td> </tr> </table>	3U	3UB	304L Stainless Steel	304L Stainless Steel	304L Stainless Steel	Bronze	304L Stainless Steel	304L Stainless Steel	Cast iron	Cast iron	<i>Stainless steel option for 3UB models</i>
3U	3UB											
304L Stainless Steel	304L Stainless Steel											
304L Stainless Steel	Bronze											
304L Stainless Steel	304L Stainless Steel											
Cast iron	Cast iron											
Shaft Seal Seal Material	Mechanical Seal – Type 21 Carbon/Ceramic/Viton Carbon/Ceramic/Buna Hot water – Carbon/Ni-Resist/Viton, 250°F (121°C) max.	Consult factory for additional optional seal availability										
Direction of Rotation	Clockwise when viewed from motor end											
Motor Type Speed Bearing Single Phase Three Phase Motor Protection	NEMA JM, TC, TSC Frame 60 Hz, 3450 RPM (2 poles) Ball Bearing TEFC – 3 HP ODP – 3 HP to 10 HP TEFC – 3 HP to 30 HP ODP – 3 HP to 30 HP 208-230/460V Overload protection must be provided	4 pole – consult factory as noted Explosion proof – consult factory for availability Washdown duty – consult factory for availability										
Standard Accessories	Suction and Discharge Flange Gasket Motor support											

Sectional view – 3U / 3UB Type 1

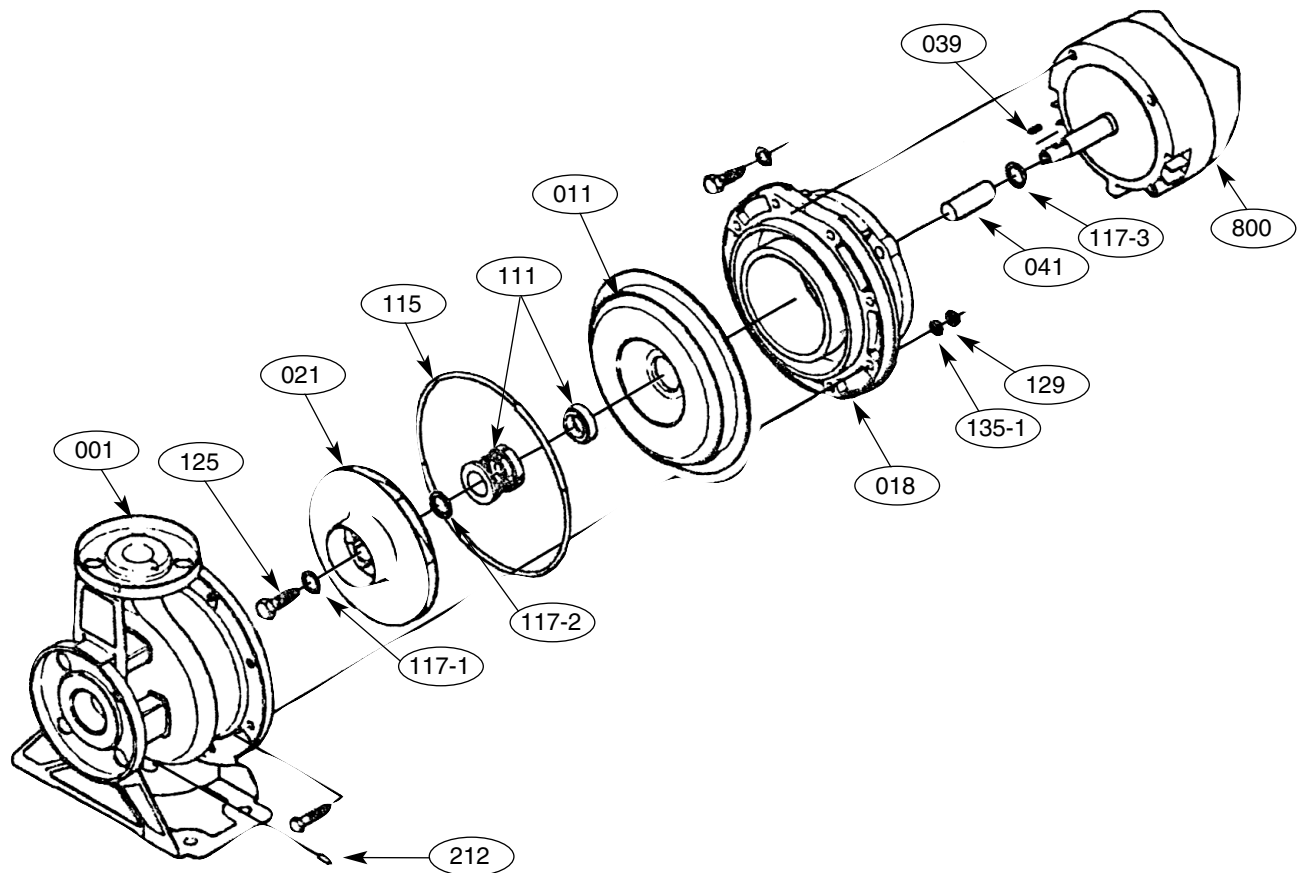

Part No.	Part Name	Material	No. for 1 Unit
001	Casing	304L Stainless	1
011	Casing cover	304L Stainless	1
018	Bracket	Cast Iron	1
021	Impeller (3U)	304L Stainless	1
021	Impeller (3UB)	Bronze	1
039	Key	304L Stainless	1
041	Shaft sleeve	304L Stainless	1
111	Mechanical seal	–	1
115	O-Ring	Viton	1
117-1	Gasket	Nylon	1
117-2	Gasket	Nylon	1
117-3	Gasket	Nylon	1
125	Impeller Bolt	304L Stainless	1
160	Motor support (not shown)	Steel	1 set
212	Plug	304L Stainless	1
800	Motor	–	1
	Suction Flange Gasket	Viton	1
	Discharge Flange Gasket	Viton	1

Operating, Installation, and Maintenance

Sectional view – Model 3U 65 Type 3

- 3U 65-160/20
- 3U 65-160/25
- 3U 65-200/20
- 3U 65-200/25
- 3U 65-200/30

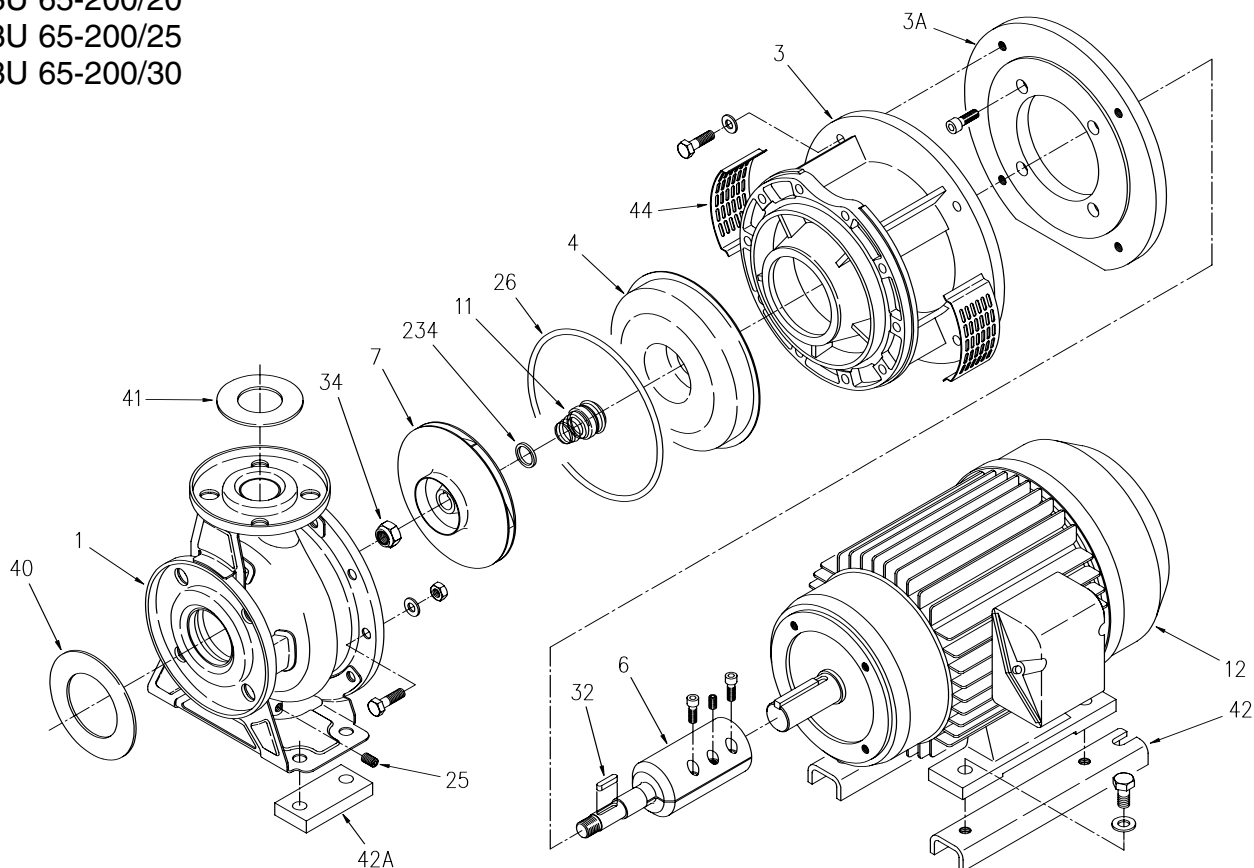

Part No.	Part Name	Material	No. for 1 Unit
001	Casing	304L Stainless	1
003	Motor bracket	Cast iron	1
003A	Adapter ring	Cast iron	1
004	Casing cover	304L Stainless	1
006	Coupling	Steel / Stainless steel	1
007	Impeller	Bronze/optional Stainless Steel	1
011	Mechanical seal		1
012	Motor		1
025	Drain plug	304L Stainless	1
026	O-ring	Viton	1
032	Key	304L Stainless	1
034	Impeller nut	Stainless / Nylon	1
040	Flange Gasket	EPDM	2
041	Flange Gasket	EPDM	2
042	Motor support	Steel	2
042A	Casing support (65-160 25HP only)	Steel	2
044	Coupling guard	Stainless Steel	2
234	Lip seal	304L Stainless	1

3U / 3UB Installation Instructions

Mounting the Assembly

Do not operate the pump unless the assembly is securely and properly mounted.

Misalignment of the motor/pump assembly or not having the assembly reasonably level may cause pump vibration, noisy operation, fluid leaks, or air leaks and air locks in the suction pipe.

1. Place the motor/pump assembly in its intended operating position.
2. Level the pump through the centerline of the motor/pump assembly suction port.



WARNING

Initial Operation

Make certain the motor is not connected to a power source until the motor is properly assembled and mounted. Serious personal injury or damage to the motor/pump assembly could occur if the motor is activated improperly.

Only certified electricians should make electrical connections.

1. Prime the pump by adding fluid to the volute case through the top plug. To properly prime the pump, venting may be required.
2. Check the nameplate on the motor to determine the correct wiring procedure for your intended power source and if the motor is single or three phase. Connect the motor to a power source by following the wiring procedure on the motor's nameplate.

Note:

- a. Single phase motors are typically dual voltage. In some cases, three phase motors are tri-voltage. Check the nameplate and follow the proper wiring procedure for the voltage you are using. Improperly wiring the motor could result in damage to the motor.
- b. Three phase motors require a control box. Install overload protection to help prevent motor damage.
- c. Depending on the wiring, three phase motors may start in reverse. Interchange any two power leads to change the starting direction and pump rotation.
 - Always follow correct operating procedures.
 - Always disconnect the motor/pump assembly from all power sources before servicing the pump or motor.
 - Periodically check all power connections, bolts, screws, and the motor's mounting.
 - Failure to properly follow assembly and operating instructions could result in damage to the pump and motor.
 - Failure to properly install the impeller and impeller nut could result in damage to the pump and could cause serious personal injury.



Operating, Installation, and Maintenance**Maintenance****Service**

Keep ventilation openings clear of extraneous objects which may hinder free flow of air thru motor. Motor bearings are lubricated during manufacture. Additional lubrication is not required during their normal lifetime.

**CAUTION****Draining**

The pump and piping should always be protected against freezing temperatures. If there is any danger of freezing, the unit should be drained. To drain the pump, remove the drain plug at the bottom of the volute, and remove the priming plug to vent the pump. Drain all piping.

Disassembly Instructions

All pumping parts can be removed from case without disturbing the piping.

**WARNING**

POWER SUPPLY – Open the power supply switch contacts and remove fuses. Disconnect the electrical wiring from the motor.

VOLUTE CASE

- (a) Drain pump case by removing drain plugs.
- (b) Remove the bolts securing volute case to pump bracket.
- (c) Pry volute case from casing cover with a screwdriver.

IMPELLER

- (a) Hold the motor shaft with a screwdriver in the shaft end slot. Grasp and turn the impeller counterclockwise (as viewed from pump end).

SEAL

- (a) Remove the rotating part of the seal by pulling it off the shaft.
- (b) The stationary seat can be pressed from the casing cover.

CHECK LIST FOR EXAMINATION OF PUMP PARTS

IMPELLER - Replace the impeller if any vane is broken, excessive erosion shows, or if labyrinth surfaces are worn. Impeller cap screw, washer and lockwasher should be replaced if damaged.

MECHANICAL SEAL - Seal face, O-ring and sealing members should be free of burrs and dirt. Complete seal assembly should be replaced if not in perfect condition.

SHAFT- Shaft sleeve surface under seal or packing must be clean, smooth and without any grooves. It should be replaced if necessary.

VOLUTE AND SEAL/PACKING PLATE LABYRINTH SURFACES (Wear Rings)- If worn, replace the necessary part. If furnished with pressed in wear rings, only the rings need be replaced.

GASKETS - Volute, suction pipe and discharge pipe gaskets should be checked for damage. Replace if necessary.

NOTE

If replacement parts are ordered, please furnish the following information to your EBARA distributor:

1. Reference Numbers
2. Description of Pump Part
3. EBARA Model Number and Serial Number on the Nameplate.



Operating, Installation, and Maintenance

3U / 3UB Assembly Instructions

Position the pump on its end with the shaft up. The work surface should be level, capable of supporting the motor.

**WARNING**

Make certain the motor is not connected to a power source. Do not install or assemble the pump on a motor connected to a power source. Serious injury could occur if the motor activates during pump assembly.

Assembling the Pump – Models 3HP - 15HP (see page 7 for sectional view)

1. Position a Nylon gasket (117-3) over the motor shaft.
2. Carefully press the rotating seal assembly onto the shaft sleeve (041). The smooth face of the rotating ring must make good contact with the seal seat and the seal retainer must seal against the shaft sleeve.
Note: Seal faces should be wiped clean with non-oil based solvent or alcohol.
3. Using finger pressure only, insert the seal seat into the casing cover (011). Press the seal until it evenly bottoms out in the seal cavity.
4. Position the cast iron motor bracket (018) over the shaft. Fasten the bracket to the motor, tightening bolts using a cross-tightening pattern. (Tighten the bolts to the factory recommended torque specifications of 8 ft. lbs.) Overtightening may cause stripping of threads.
5. Carefully position the casing cover (011) and seal over the shaft. Be careful not to damage the stationary seal seat.
6. Slide the stainless steel shaft sleeve, with rotating assembly, over the motor shaft.
7. Position the O-ring (115) around the casing cover (011). Do not cut, nick, or damage the O-ring during the installation.
8. Install the impeller shaft key ($\frac{3}{16}$ " x $\frac{3}{16}$ " x 1 $\frac{3}{16}$ ").
9. Place the seal spring assembly over the rotating piece of the seal in position to receive the impeller.
10. Place a Nylon gasket (117-2) on top of spring retainer.
11. Firmly press the impeller (021) into position by aligning the slot over the shaft key. Press the impeller down the shaft until it bottoms and seats squarely against the Teflon gasket (117-2) and shaft sleeve (041).
12. Place a Nylon gasket (117-1) over the impeller hub and into the impeller eye. Install the impeller bolt (125) to secure the impeller to the shaft. Do not overtighten the shaft bolt. (Use a thread compound or cement to secure the shaft bolt and prevent it from working loose.)
13. Tighten the impeller bolt. (Tighten the bolts to the factory recommended torque specifications of 11 ft. lbs.)
14. Install the pump volute (001) over the seal plate. Rotate the volute to align with the bolt holes and secure it with the bolts, washers, and nuts. Cross-tighten the bolts to the factory recommended torque specifications (8 ft. lbs.).
15. With a socket wrench, rotate impeller to check for alignment. If rubbing against casing, loosen bolts on casing and retighten.



Operating, Installation, and Maintenance

Assembling the Pump – Models 20HP - 30HP (see page 8 for sectional view)

1. Apply a coat of anti-seize lubricant to the inside of the coupling (005).
2. Insure that key is installed in motor shaft keyway, slide coupling (005) onto shaft. (*Tip:* To ease the installation of the coupling tighten the set screw on the side of the coupling. Tightening this screw will cause the coupling to open slightly allowing for easier installation. After the coupling is in place be sure to loosen the set screw to release the pressure and allow the coupling to close down on the motor shaft.)
3. Secure the coupling to the motor shaft by tightening the socket head bolts in the side of the coupling. Torque to 11ft. lbs.
4. Fasten the adapter ring (003A) to the motor using a cross tightening pattern.
5. Fasten the motor bracket (003) to the adapter ring.
6. Apply a thin coat of non-petroleum based lubricant (i.e. dish soap) to the stationary seal seat in the casing cover (004), using finger pressure only press the stationary seal into the seal seat. Wipe the seal face clean with alcohol and a soft cloth.
7. Position the o-ring (026) around the casing cover.
8. Using hand pressure or a rubber mallet, press fit the casing cover (004) onto the motor bracket (003).
9. Apply a thin coat of non-petroleum based lubricant (i.e. dish soap) to the inside of the rubber boot on the rotating seal. Slide the seal onto the coupling pushing it gently until it contacts the stationary seal that was installed in step 6. Place the spring and spring retainer over the coupling and onto the rotating seal.
10. Place the stainless steel lip seal (234) onto the spring retainer insuring that the raised surface of the lip seal seats into the spring retainer.
11. Install the impeller shaft key (032) into the coupling shaft.
12. Slide impeller (007) over the key and shaft.
13. Tighten the impeller nut (034) to secure the impeller in place. Tighten to 11 ft.lbs
14. Install Casing (001). Take care to align the bolt holes. Cross tighten the bolts to 8 ft. lbs.
15. With a socket wrench, rotate impeller to check for proper casing alignment. If rubbing against casing occurs loosen casing bolts and retighten taking care to cross-tighten and use equal torque.
16. Install motor support (042) or casing support (042A) as required.



Operating, Installation, and Maintenance

Troubleshooting

TROUBLE	POSSIBLE CAUSE	TROUBLESHOOTING
Pump does not run.	Faulty connection of power supply circuit. Wrong wiring of control circuit. Bound shaft Mechanical seal faces stuck together Faulty motor Damage to bearing	Check power supply circuit. Correct control circuit. Remove cause of obstruction. Release seal by turning shaft. Repair or replace motor. Repair or replace any damaged bearing.
Pump does not pump water. Inadequate quantity.	Considerable voltage drop. Rotation direction reversed. Lack of priming. High discharge head. Large piping loss. Clogged foot valve. Leakage from suction piping. Too high suction lift. Low water level.	Correct rotation direction. Re-prime the pump. Re-examine the plan. Re-examine the plan. Clear foot valve suction. Check and repair suction piping. Re-install as per our instructions. Foot valve in ample immersion.
Overcurrent	Considerable fluctuation of power supply voltage. Considerable voltage drop. Low head and overflow rate. Damaged bearing.	Throttle flow rate at outlet. Replace any damage bearing.
Pump vibrates, excessive operating noise	Beyond rated capacity. Cavitation. Improper piping. Damaged bearing. Foreign matter clogging cooling fan.	Reduce flow rate. Consult distributor Secure piping again. Replace any damaged bearing. Remove foreign matter.
Pressurizing application. Pump starts and soon stops	Too limited pressure switch setting.	Replace pressure switch to wider range. Check and repair leaks.
Pump does not stop	Leakage in system. Too high pressure setting.	Reduce max pressure setting to the lower in pressure switch.

MAINTENANCE:

The pump does not require special maintenance.

The following rules must be observed for safe operation:

If the pump is not going to be used for a long period, the pump should be drained of water and flushed with clean water.

Where the pump is exposed to freezing temperatures, it should always be left drained when not in use.

*All specifications subject to change without notice.





***Contact your dealer or supplier
for more information about other EBARA products***



EBARA Fluid Handling

1651 Cedar Line Drive • Rock Hill, SC 29730

(t) 803 327 5005 • (f) 803 327 5097

www.pumpsebara.com

© 2005 EBARA International Corporation

EFH 3U_3UB0107