

Single Phase Simplex SJE-Rhombus® Type 113

Installation Instructions and Operation/Troubleshooting Manual

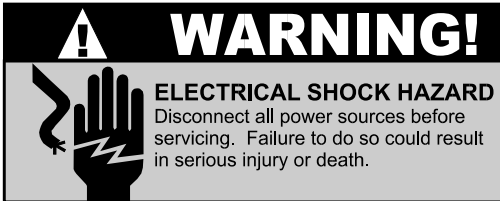

This control panel must be installed and serviced by a licensed electrician in accordance with the National Electric Code NFPA-70, state and local electrical codes.

All conduit running from the sump or tank to the control panel must be sealed with conduit sealant to prevent moisture or gases from entering the panel. NEMA 4X enclosures are for indoor or outdoor use, primarily to provide a degree of protection against corrosion, windblown dust and rain, splashing water and hose-directed water. **Cable connectors must be liquid-tight in NEMA 4X enclosures.**

Installation

Standard Type 113 panels are designed to operate with three floats. These floats operate the pump stop, pump start, and high level alarm functions.

NOTE: Options ordered may affect the number of floats and their functions. Please reference the schematic provided with the control panel for proper installation.

Installation of Floats

CAUTION: If control switch cables are not wired and mounted in the correct order, the pump system will not function properly.

WARNING: Turn off all power before installing floats in pump chamber. Failure to do so could result in serious or fatal electrical shock.

1. Use float label kit to identify and label cables on both the float and stripped ends (stop, start, alarm, etc.). See schematic for float options.
2. Determine your normal operating level, as illustrated in **Figure 1**.
3. Mount float switches at appropriate levels as illustrated in **Figures 2-4**. Be sure that floats have free range of motion without touching each other or other equipment in the basin.

If using the mounting clamp; follow steps 4-6.

4. Place the cord into the clamp as shown in **Figure 2**.
5. Locate the clamp at the desired activation level and secure the clamp to the discharge pipe as shown in **Figure 2**.

NOTE: Do not install cord under hose clamp.

6. Tighten the hose clamp using a screwdriver. Over tightening may result in damage to the plastic clamp. Make sure the float cable is not allowed to touch the excess hose clamp band during operation.

NOTE: All hose clamp components are made of 18-8 stainless steel material. See your SJE-Rhombus® supplier for replacements.

Warranty void if panel is modified.

Call factory with servicing questions:
1-800-RHOMBUS
(1-800-746-6287)

Manufactured by:

SJE
Rhombus
CONTROLS

22650 County Highway 6 ■ P.O. Box 1708
Detroit Lakes, Minnesota 56502 USA
1-888-DIAL-SJE (1-888-342-5753)
Phone: 218-847-1317 ■ Fax: 218-847-4617
E-mail: sje@sjerhombus.com
Website: www.sjerhombus.com

©SJE-Rhombus
Printed in USA
PN1008694B • Rev 10/00

Installation Instructions

Mounting the Control Panel

1. Determine mounting location for panel. If distance exceeds the length of either the float switch cables or the pump power cables, splicing will be required. For outdoor or wet installation, we recommend the use of a SJE-Rhombus® liquid-tight junction box with liquid-tight connectors to make required connections. **You must use conduit sealant to prevent moisture or gases from entering the panel.**
2. Mount control panel with mounting devices furnished.
3. Determine conduit entrance locations on control panel.

NOTE: Be sure the incoming power, voltage, amperage, and phase meet the requirements of the pump motor being installed. If in doubt, see the pump identification plate for electrical requirements.

4. Drill proper size holes for type of connectors being used.

NOTE: If using conduit, be sure that it is of adequate size to pull the pump and switch cables through.

5. Attach cable connectors and/or conduit connectors to control panel.

FOR INSTALLATIONS WITHOUT A SPLICE, GO TO STEP 10; FOR INSTALLATIONS REQUIRING A SPLICE, FOLLOW STEPS 6-9.

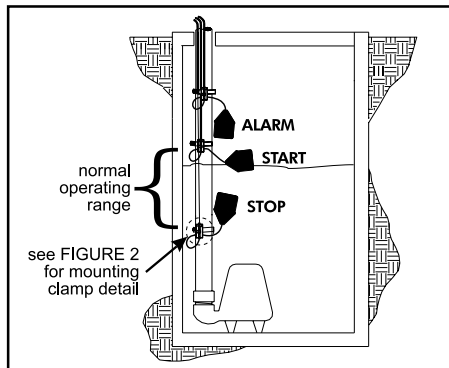

FIGURE 1 - Three float simplex - pump down installation

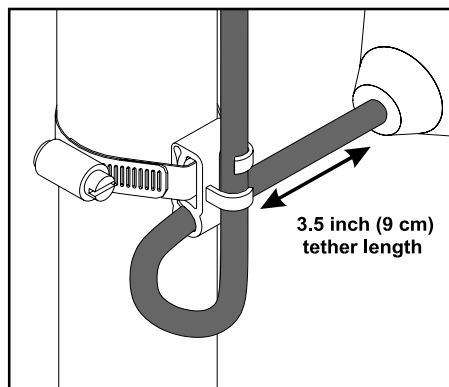

FIGURE 2 - Mounting clamp detail

6. Determine location for mounting junction box according to state and local code requirements. Mount junction box to proper support.
7. Run conduit to junction box. Drill proper size holes for the type of conduit used. Attach connectors to junction box.
8. Identify and label each wire before pulling through conduit into control panel and junction box. Make wire splice connections at junction box.
9. Firmly tighten all fittings on junction box.
10. If a junction box is not required, pull cables through conduit into control panel.
11. Connect pump and float wires to proper position on terminals. See schematic inside control panel for terminal connections.
12. Connect control, alarm, and pump power conductors to proper position on terminals. See schematic inside control panel for terminal connections.

NOTE: It is the recommendation of the factory to use separate pump and control/alarm power sources.

VERIFY CORRECT OPERATION OF CONTROL PANEL AFTER INSTALLATION IS COMPLETE.

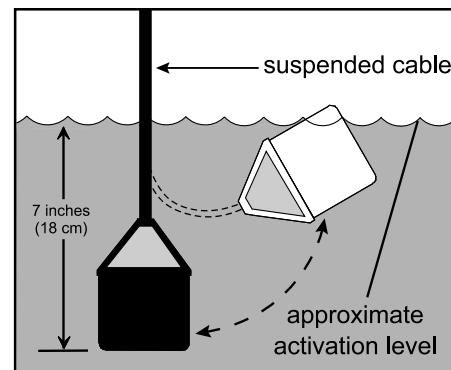

FIGURE 3 - Internally weighted float

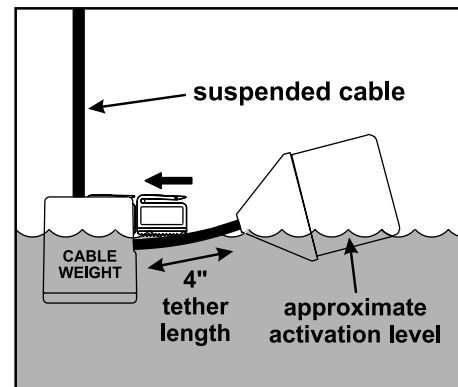

FIGURE 4 - Float with cable weight

Operations

SJE-Rhombus® Type 113 control panels are designed to operate in a three float system as standard. When all floats are in the open or OFF position, the panel is inactive. As the liquid level changes and closes the stop float, the panel remains inactive until the start float also closes. At this point the pump will start, assuming the HOA switch is in the AUTOMATIC mode and the power is ON. The pump will remain ON until both the stop and start floats open (return to the OFF position). If the liquid level travels beyond both the stop and start floats and reaches the alarm float, the audio/visual alarm will be activated. The alarm horn can be silenced by moving the test/normal/silence switch to the silence position.

Alarm System (Horn and Indicator - standard)

When an alarm condition occurs, a red light and a horn will be activated. If the test/normal/silence switch is moved to the silence position, the horn will be silenced. When the alarm condition is cleared, the alarm system is reset. The alarm system can be tested by moving the test/normal/silence switch to the test position.

Circuit Breaker (optional)

The pump circuit has a thermal-magnetic circuit breaker which provides pump disconnect and branch circuit protection.

Dry Auxiliary Contacts (optional)

Normally open - Contacts are open under normal conditions and closed when an alarm condition is present.

Normally closed - Contacts are closed under normal conditions and open when an alarm condition is present.

Both types automatically reset once the alarm condition is cleared.

HOA Switch

A hand-off-automatic switch is provided for the pump. In the hand mode, the pump will turn on unless other safety features are employed. In the automatic mode, the pump will turn on from commands by the float switches.

Overload Relay (optional)

An overload relay is supplied in the pump circuit. The overload must be set in the field. Dial the amp scale to the pump full load amps. If the full load amps are unknown, use a calibrated ammeter to measure the pump amperage draw under loaded conditions. An auxiliary contact from the overload is wired in series with the magnetic contactor coil so that on a trip, the magnetic contactor will be disabled. The overload relay must be reset on an overload trip.

Pump Run Light

The run light will be ON in either the hand or the automatic mode when the pump is called to run.

Seal Failure Circuit and Indicator Light (Optional)

The seal fail circuit has resistance sensitivity and will sense the presence of water in the pump seal chamber. Upon installation, turn the sensitivity dial on the seal fail module to the point where the light turns on, then dial back slowly until the light turns off. If water enters the seal chamber at this point, the seal chamber circuit will sense a change in resistance. After a short time delay, the indicator light will turn on. When the condition is cleared, the relay will de-energize and the indicator light will turn off. The seal fail relay has a sensitivity adjustment so that false readings may be tuned out.

Thermal Cutout (Optional)

The thermal cutout circuit is wired in series with the magnetic contactor coil. If the pump's thermal switch opens on high temperature, the magnetic contactor will turn off and stop the pump. When the thermal switch cools and closes, the magnetic contactor will turn on if the pump is called to run.

NOTE: Some options ordered may not be included in this manual.

Troubleshooting

Alarm Horn

Moving the alarm test/normal/silence switch to the test position or activating the alarm float should turn on the alarm horn. If the horn does not sound replace with horn of same type.

Alarm Light

Moving the alarm test/normal/silence switch to the test position or activating the alarm float should turn on the alarm light. If the light does not activate, replace with bulb of same type.

Circuit Breaker (optional)

Check each pole of the circuit breaker for proper resistance reading using the following procedure.

Warning: Disconnect incoming power to panel.

1. Isolate the circuit breaker by disconnecting either the line side or load side wires.
2. Place the ohmmeter leads across the corresponding line and load terminals of each pole.

3. With the ohmmeter on the R X 1 scale and the breaker in the OFF position, the reading should be infinity (very high resistance). With the breaker in the ON position, the reading should be zero ohms (very low resistance). If the readings are not as stated, replace the circuit breaker with one of the same ratings.

NOTE: Reading may vary slightly depending accuracy of the measuring device.

Float Controls

Check the floats during their entire range of operation. Clean, adjust, or replace floats.

Checking the float resistance - The float resistance can be measured to determine if the float is operating correctly or is defective. Use the following procedure to measure the float resistance:

1. Isolate the float by disconnecting one or both of the float leads from the float terminals.

(Troubleshooting - continued on next page)

Troubleshooting

- Place one ohmmeter lead on one of the float wires, and the other ohmmeter lead on the other float wire.

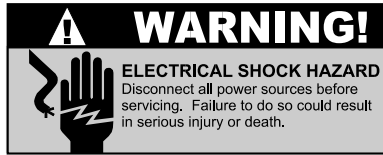

- Place the ohmmeter dial to read ohms and place on the R X 1 scale. With the float in the "off" position, the scale should read infinity (high resistance). Replace the float if you do not get this reading. With the float in the ON position, the scale should read nearly zero (very low resistance). Replace the float if you do not get this reading.

NOTE: Readings may vary depending on the length of wire and accuracy of the measuring device.

Fuses

Check the continuity of the fuse. With power OFF, pull the fuse out of the fuse block. With the ohmmeter on the R X 1 scale, measure resistance. A reading of infinity indicates a blown fuse and must be replaced. Replace fuse with same type, voltage and amp rating.

IEC Contactor

Contacts - Check the contacts for severely burnt or welded contacts. The contactor arm should move freely.

Coil - Measure the coil by disconnecting one of the coil leads. Measure the coil resistance by setting the ohmmeter on the R X 1 scale. A defective coil will read zero or infinity, indicating a short or opened coil respectively. Replace defective contactor with same type.

NOTE: Readings may vary depending on accuracy of the measuring device.

Overload Relay (optional)

Test by pressing the test pin on the relay. The relay should trip.

Start and Run Capacitor

A failed capacitor will have a bulged enclosure, leading oil or a burnt smell. Using the following procedure, check the capacitor with an ohmmeter to determine if the capacitor is defective.

- With the power OFF, discharge capacitor by shorting both terminals with an insulated handle metal screwdriver.
- Label and remove the wires from the capacitor.
- Set the ohmmeter on the R X 10,000 (10K) scale. Place an ohmmeter lead on each capacitor lead.
- If the capacitor is good, the ohmmeter needle will go towards zero and then drift slowly toward infinity. If you do not get this reading, replace capacitor with one of the same type.

NOTE: If the capacitor is checked a second time, be sure to reverse the ohmmeter leads to get a correct ohm reading.

Start Relay

- With power OFF, disconnect and label the wires going to the start relay.
- To check coil resistance, set the ohmmeter to the R X 1,000 scale. A reading of zero ohms indicates a defective relay.
- When checking contact resistance, a reading other than zero indicates a defective relay. (See schematic for relay pin numbers.)

SJE-Rhombus® Three-Year Limited Warranty

SJE-RHOMBUS® warrants to the original consumer that this product shall be free of manufacturing defects for three years after the date of consumer purchase. During that time period and subject to the conditions set forth below, **SJE-RHOMBUS®** will repair or replace, for the original consumer, any component which proves to be defective due to defective materials or workmanship of **SJE-RHOMBUS®**.

THIS EXPRESS WARRANTY DOES NOT APPLY TO THE MOTOR START KIT COMPONENT. SJE-RHOMBUS® MAKES NO WARRANTIES OF ANY TYPE WITH RESPECT TO THE MOTOR START KIT.

ELECTRICAL WIRING AND SERVICING OF THIS PRODUCT MUST BE PERFORMED BY A LICENSED ELECTRICIAN.

THIS WARRANTY DOES NOT APPLY: (A) to damage due to lightning or conditions beyond the control of **SJE-RHOMBUS®**; (B) to defects or malfunctions resulting from failure to properly install, operate or maintain the unit in accordance with printed instructions provided; (C) to failures resulting from abuse, misuse, accident, or negligence; (D) to units which are not installed in accor-

dance with applicable local codes, ordinances, or accepted trade practices, and (E) to units repaired and/or modified without prior authorization from **SJE-RHOMBUS®**.

Some states do not allow limitations on how long an implied warranty lasts, so the above limitation may not apply to you. Some states do not allow the exclusion or limitation of incidental or consequential damages, so the above limitation or exclusion may not apply to you. This warranty gives you specific legal rights, and you may also have other rights which vary from state to state.

TO OBTAIN WARRANTY SERVICE: The consumer shall assume all responsibility and expense for removal, reinstallation, and freight. Any item to be repaired or replaced under this warranty must be returned to **SJE-RHOMBUS®**, or such place as designated by **SJE-RHOMBUS®**.

ANY IMPLIED WARRANTIES OF MERCHANTABILITY OR FITNESS ARE LIMITED TO THE DURATION OF THIS WRITTEN WARRANTY. SJE-RHOMBUS® SHALL NOT, IN ANY MANNER, BE LIABLE FOR ANY INCIDENTAL OR CONSEQUENTIAL DAMAGES AS A RESULT OF A BREACH OF THIS WRITTEN WARRANTY OR ANY IMPLIED WARRANTY.