

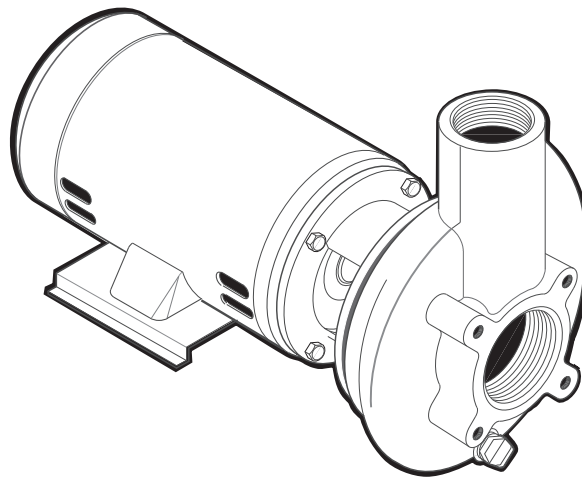

STA-RITE®**“C” and “CC” Series****Installation/Operation/Parts**

For further operating, installation,
or maintenance assistance:

Distributed by:
PumpBiz, Inc
800-PumpBiz (786-7249)
www.PumpBiz.com

READ AND FOLLOW SAFETY INSTRUCTIONS!

 **This is the safety alert symbol.** When you see this symbol on your pump or in this manual, look for one of the following signal words and be alert to the potential for personal injury:

 **DANGER** warns about hazards that **will** cause serious personal injury, death or major property damage if ignored.

 **WARNING** warns about hazards that **can** cause serious personal injury, death or major property damage if ignored.

 **CAUTION** warns about hazards that **will** or **can** cause minor personal injury or property damage if ignored.

The label **NOTICE** indicates special instructions which are important but not related to hazards.

Carefully read and follow all safety instructions in this manual and on pump.

Keep safety labels in good condition.
Replace missing or damaged safety labels.

 **CAUTION** Motor normally operates at high temperature and will be too hot to touch. It is protected from heat damage during operation by an automatic internal cutoff switch. Before handling pump or motor, stop motor, and allow it to cool for 20 minutes.

California Proposition 65 Warning

 **WARNING** This product and related accessories contain chemicals known to the State of California to cause cancer, birth defects or other reproductive harm.

SERIES C/CC CENTRIFUGAL PUMPS

The “C” and “CC” Series pumps are close coupled pumps with optional traps. “CC” Series have cast iron volutes and adapters. “C” Series have bronze volutes and adapters. Impellers on both series are bronze.

INSTALLATION

Location of Unit

Install pump as close to liquid source as possible, using short, simple suction piping.

Piping should be as direct as possible; elbows and other fittings greatly increase friction losses.

Allow service and maintenance access.

Mount on solid, rigid, vibration-free foundation.

Protect pump against flooding and excess moisture.

Piping

Pump is not self-priming. Unless liquid source level is above pump suction at all times, install a foot valve on suction pipe.

Support both suction and discharge piping independently near the pump to avoid placing strains on pump. Start all piping at pump to avoid strains left by a gap at last connection.

If possible, increase size of both suction and discharge piping if more than short runs are required.

NOTICE: Never use a suction pipe smaller than the suction connection of the pump.

NOTICE: If a reducer is necessary in the suction piping, always use an eccentric reducer with the straight side on top.

NOTICE: BE SURE suction does not leak. Suction pipe must slope gradually upward to the pump. Avoid any fittings which might cause an air trap.

Install gate valve and union in suction and discharge lines. If complete pump removal is required for service, close gate valves and disconnect at unions.

Grounding the Motor



Can shock, burn or cause death.

Ground motor before working on pump or motor.

Install, ground, wire and maintain this pump in accordance with the National Electrical Code, Article 250, or applicable local Codes and Ordinances.

Ground the pump permanently using a wire of size and type specified by National or Local Electrical Code.

Connect ground wire first. Connect to ground first, then to motor terminal provide. Do not connect motor to electrical power supply until unit is permanently grounded. Any other sequence may cause serious shock hazard. **Do not ground to a gas supply line.**

The motor grounding wire need not be larger than the wires supplying the motor, provided the supply wires conform to the wiring date included in this manual (see Table I, Page 5).

Wiring

NOTICE: For 575 volt installations, see motor nameplate. Consult a licensed electrician for wiring information. Installation must meet code.

For 200, 230, and 460 volt installations, check fusing/wiring data chart (Table I, below) before connecting pump to power source.

Check that voltage/frequency on motor nameplate are **identical** with voltage/frequency of incoming power supply.

NOTICE: Wire dual voltage motors correctly according to wiring diagram on motor.

Check rotation of motor. Look through opening in adapter. Rotation should be clockwise when viewed from the motor end. If not:

- Turn pump OFF and disconnect from power source.
- For three-phase motors, reverse any two leads to motor starter.
- For single phase motors, re-connect according to wiring diagram on motor.

Priming the Pump

NOTICE: NEVER run pump dry. To run pump dry may damage seals. To Prime:

1. If pump is installed below liquid source level, open gate valve in suction line and flood suction.
2. If pump is not installed below liquid source level, fill pump through a tee installed in pump discharge and fitted with a priming plug in the upright position.

Tighten priming plug securely after priming!

TABLE I - RECOMMENDED FUSING AND WIRING DATA - 60 CYCLE MOTORS

MOTOR HP	PHASE	VOLTS	MAX. LOAD AMPS	BRANCH FUSE* RATING AMPS	DIAMETER IN FEET FROM MOTOR TO METER (METERS)				
					0'(0) TO 100'(30)	101'(31) TO 200'(61)	201'(62) TO 300'(91)	301'(92) TO 400'(122)	401'(123) TO 500'(152)
					WIRE SIZE				
3	1	230	17.0	25	10 (5.5)	10 (5.5)	10 (5.5)	8 (8.4)	8 (8.4)
3	3	200	11.0	15	14 (2)	14 (2)	12 (3)	10 (5.5)	10 (5.5)
3	3	230	9.6	15	14 (2)	14 (2)	12 (3)	12 (3)	10 (5.5)
3	3	460	4.8	15	14 (2)	14 (2)	14 (2)	14 (2)	14 (2)
5	1	230	28.0	40	8 (8.4)	8 (8.4)	8 (8.4)	6 (14)	6 (14)
5	3	200	17.5	25	10 (5.5)	10 (5.5)	10 (5.5)	8 (8.4)	8 (8.4)
5	3	230	15.2	20	12 (3)	12 (3)	10 (5.5)	10 (5.5)	8 (8.4)
5	3	460	7.6	15	14 (2)	14 (2)	14 (2)	14 (2)	14 (2)

* Time delay fuse or circuit breakers are recommended in any motor circuit.

IMPORTANT: BE SURE lead wire opening on end of motor is fully sealed when conduit or a pressure switch is not used. Failure to seal it properly will allow dirt, rain,

bugs, etc. to enter back compartment of motor through conduit opening and cause switch malfunction.

MAINTENANCE

Little or no maintenance to pump is required other than possible replacement of shaft seal after a reasonable period of operation (see below).

Lubricate motor according to motor manufacturer's instructions. Periodic greasing is required for most motors.

PUMP STORAGE

Drain pump to prevent freezing.

Keep motor dry and loosely covered. Do not wrap with plastic sheeting; trapped moisture could cause corrosion or insulation deterioration.

NOTICE: A good rust inhibitor in the liquid end of cast iron pumps is recommended to prevent excessive corrosion.

PUMP START-UP AFTER STORAGE

Replace all drain plugs and close all drain valves in system.

Be sure all connections are tightly sealed.

After initial check is made, fill pump according to "Priming the Pump" above.

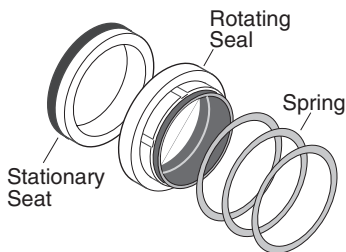

Figure 1

SHAFT SEAL REPLACEMENT

NOTICE: The highly polished and lapped faces of the seal are easily damaged. Follow instructions and handle the seal with care.



WARNING Be sure unit is grounded and power disconnected before attempting any work on pump or motor.
Hazardous voltage

REMOVAL OF OLD SEAL

Refer to Figure 1 for Mechanical Seal parts identification.

1. Remove motor hold down bolts and bolts holding adapter/seal plate to volute. Slide motor, adapter/seal plate and impeller backward to clear volute.
2. Remove impeller screw and washer from end of shaft and slide impeller off of shaft.
3. Unbolt adapter/seal plate from motor.
4. Use two screwdrivers (Figure 2) or bearing puller to carefully separate motor from adapter/seal plate, bringing rotating half of seal off with adapter/seal plate. Shaft sleeve may come off with seal.
5. Use hammer, if necessary, to drive shaft sleeve out of seal. Clean up shaft sleeve with emery paper if necessary.
6. Place adapter/seal plate face down on bench and drive old stationary half of seal out of adapter/seal plate by carefully tapping with screwdriver and hammer (Figure 3).
7. Use a wire brush to thoroughly clean adapter/seal plate cavity. Be sure all dust and grime are out of seal cavity before installing new seal.

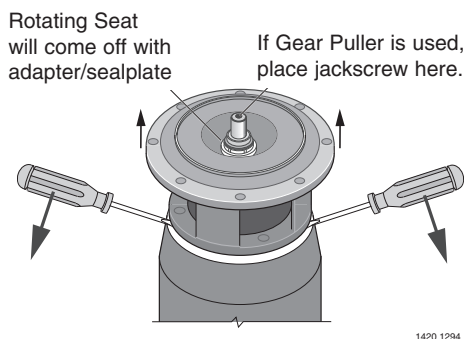
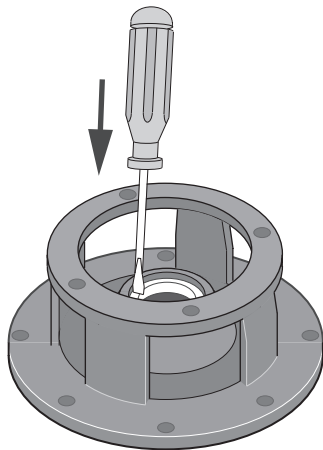

Figure 2

1420 1294



1421 1294

Figure 3

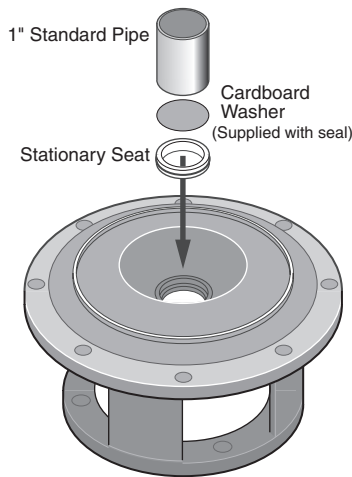

1422 1294

Figure 4

INSTALLING NEW SEAL

1. **NOTICE:** Seal faces are highly polished and lapped. **Handle with care.** Any mar, nick or scratch on seal face will cause it to leak. **BE SURE** to install with polished faces toward each other.
2. Clean polished surface of ceramic seat with clean cloth.
3. Wet O-Ring around ceramic seat with liquid soap.
4. Press stationary (ceramic) half of seal cavity into cavity firmly and squarely with thumb pressure. If it does not seat properly, remove and place seal face up on bench. Re-clean adapter/seal plate cavity. Seal should now seat correctly.
5. If seal does not seat after re-cleaning adapter/seal plate cavity, place a cardboard washer over polished face of seal and **carefully** press into place using a piece of 1" standard pipe as a press (Figure 4).
NOTICE: BE SURE you do not scratch seal face.
6. Dispose of cardboard washer and recheck seal face to be sure it is free of dirt, foreign particles, scratches and grease.
7. Inspect shaft and shaft sleeve to be sure they are clean.
8. Re-install O-Ring, shaft sleeve and slinger on shaft.
NOTICE: A small amount of grease or Never-Seez under shaft sleeve will help prevent shaft and sleeve from freezing together when pump is in service.
9. Remount adapter/seal plate to motor, being careful not to scratch seal face.
10. Apply liquid soap to inside diameter and outside face of rubber drive ring on rotating half of seal.
11. Slide seal assembly onto shaft sleeve (sealing face first) far enough so that seal spring is located on shaft sleeve.
NOTICE: Be careful not to nick carbon seal face when passing it over end of shaft sleeve.
12. Slide impeller and gaskets onto shaft with key in position. Be sure to maintain proper order as shown in Exploded View, Page 9.
13. Install washer and impeller screw on end of shaft and tighten screw until it is snug. This should locate seal in place and bring seal faces together.
14. Reinstall motor, adapter and impeller assembly on volute, using new gasket.
15. Reinstall motor hold-down bolts.
16. Check all bolts for tightness.

Read symptom describing problem below at left. Causes for problems (bottom) are keyed to numbers at right. Check pump for causes listed at right and correct those that apply.

⚠ WARNING Hazardous voltage. Can shock, burn or kill. Take all normal precautions for the voltage involved.

SYMPTOM

Pump does not deliver liquid

Pump delivers too little flow

Delivery pressure too low

Pump loses prime after starting

Pump needs too much power

Seal leaks

Pump vibrates or is noisy

Motor bearings have short life

Pump overheats and/or seizes

KEY NUMBERS FOR CAUSES

1, 2, 3, 4, 6, 10, 12, 14, 15, 20, 21

2, 3, 4, 5, 6, 7, 8, 9, 10, 11, 12, 13, 15, 18, 20, 21, 27, 28

5, 12, 13, 14, 15, 18, 20, 27, 28

2, 3, 5, 6, 7, 10

13, 14, 15, 16, 17, 18, 21, 22, 24, 25, 27

22, 24, 29, 30

2, 3, 4, 8, 9, 10, 11, 19, 21, 22, 23, 24, 25, 26, 28, 29, 30, 31, 32, 33, 34

22, 24, 25, 26, 29, 30, 31, 32, 33, 34

1, 4, 19, 20, 22, 25, 26, 29, 30

CAUSES

1. Pump not primed.
2. Pump or suction pipe not completely full of liquid.
3. Suction lift too high.
4. Pump cavitating; increase suction pressure.
5. Excessive amount of air or gas in liquid.
6. Air pockets in suction pipe.
7. Air leakage in suction pipe.
8. Foot valve too small.
9. Foot valve partially clogged.
10. Suction pipe inlet not sufficiently submerged.
11. Impeller, suction or trap partially or completely plugged.
12. Speed too low.
13. Voltage wrong or too low.
14. Wrong direction of rotation.
15. System head too high for pump design.
16. System head too low for pump design.
17. Specific gravity of liquid different than design.
18. Viscosity of liquid different than design.
19. Pump operating at very low capacity.
20. Parallel operation of pumps unsuited for such operation.
21. Foreign matter in impeller.
22. Misalignment of pump or piping.
23. Foundations not rigid.
24. Shaft bent.
25. Rotating part rubbing on stationary part.
26. Bearings worn.
27. Wear ring worn.
28. Impeller damaged.
29. Shaft running off center due to worn bearings or misalignment.
30. Impeller out of balance resulting in vibration.
31. Excessive grease in bearing causing high bearing temperature.
32. lack of lubrication.
33. Dirt in bearings.
34. Rust in bearings due to water getting into motor.

6" Suction Trap

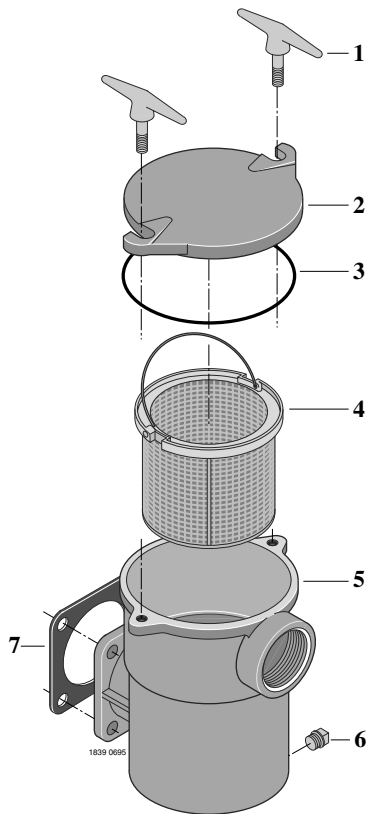

NOTICE:
Traps are not included with pumps.

8" and 11" Suction Trap

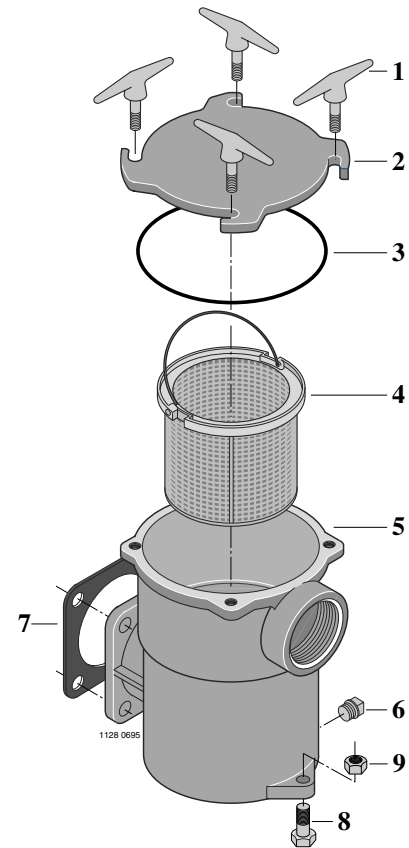

Key No.	Part Description	Cast Iron	Bronze
1*	Lock Handle	C154-18D	C154-18D
2	Cover - 6"	C30-30	C3-78DZZ
2	Cover - 8"	C3-105	C3-105D
2	Cover - 11"	C3-76	-
3	O-Ring - 6"	U9-46	U9-46
3	O-Ring - 8"	U9-171	U9-171
3	O-Ring - 11"	U9-105	-
4	Strainer Basket - 6"	C108-11P	C108-11P
4	Strainer Basket - 8"	C108-34SS	C108-34SS
4	Strainer Basket - 11"	C108-25SS	-
5	Suction Trap Body - 6"	C53-5B	C53-5D
5	Suction Trap Body - 8"	C53-21	C53-21D
5	Suction Trap Body - 11"	C53-8	-
6**	Pipe Plug 1/4"	U78-57DT	U78-57DT
7	Gasket, Flange	C20-19	C20-19
8	Capscrew, 3/8-16x1-3/4"	-	U30-77C
9	Nut, Hex 3/8-16	-	U36-38C
•	Capscrew, 5/16-18x7/8"	U30-61C(4)	U30-61C(4)
	Suction Trap Complete - 6"	Pkg. #51	Pkg. #56
	Suction Trap Complete - 8"	Pkg. #98	Pkg. #99
	Suction Trap Complete - 11"	Pkg. #74	-

Quantity 1 unless otherwise noted ().

• Not illustrated.

* 6" has 2 each; 8" & 11" have 4 each.

** 6" & 8" have 1 each; 11" has 2 each.

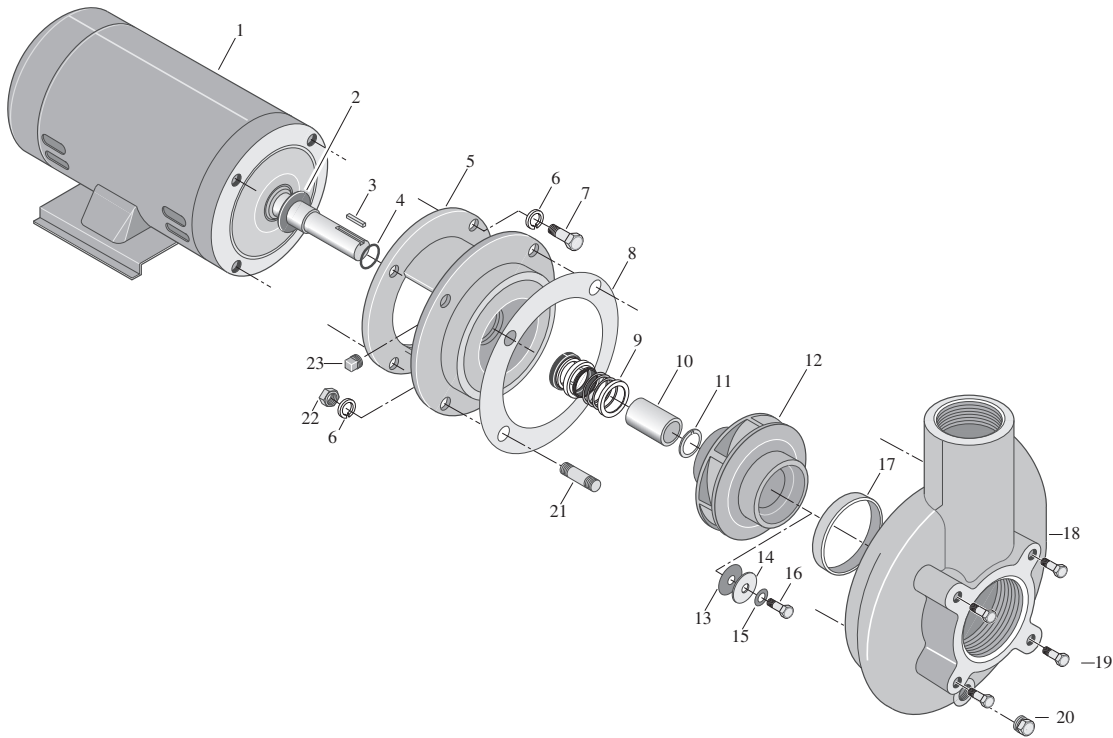

Key No.	Description	Qty.	CCMH-136 CCM2H-136 CCM2H-136S CCMH3-136S CCM2H3-136 CCM2H3--136S 3 HP	CMH-136 CMH3-136 CCMH36-136 CM2H-136 CM2H3-136 3 HP	CCHH-137S CCHH3-137S CCHH36-137 CCH2H-137S CCH2H3-137 CCH2H3-137S 3 HP	CHH-137 CHH3-137 CH2H3-137 3 HP
1	Motor 230V/60H/1 Ph.	1	C218-177	C218-177	C218-177	C218-177
1	Motor 230/460V/60H/3 Ph.	1	C218-179	C218-179	C218-179	C218-179
1	Motor 575V/60H/3 Ph.	1	-	C218-290C	C218-290C	-
1	Motor 200V/60H/1 Ph.	1	C218-191	C218-191	C218-191	C218-191
1	Motor 200V/60H/3 Ph.	1	C218-178	C218-178	C218-178	C218-178
2	Water Slinger-1 Ph.	1	C69-15	C69-15	C69-15	C69-15
2	Water Slinger-3 Ph. (+)	1	C69-16	C69-16	C69-16	C69-16
3	Key, Impeller	1	U65-42A	U65-42A	U65-42A	U65-42A
4	O-Ring	1	U9-265	U9-265	U9-265	U9-265
5	Adapter	1	C2-81	C2-81D	C2-81	C2-81D
6	Lockwasher, 3/8"	8	U43-12ZP	U43-12ZP	U43-12ZP	U43-12ZP
7	Capscrew, 3/8-16x7/8"	4	U30-73ZP	U30-73ZP	U30-73ZP	U30-73ZP
8	Gasket	1	C20-77	C20-77	C20-77	C20-77
9	Shaft Seal	1	U109-433SS	U109-433SS	U109-433SS	U109-433SS
10	Shaft Sleeve	1	C23-58	C23-58	C23-58	C23-58
11	Gasket, Sleeve	1	C20-101	C20-101	C20-101	C20-101
12	Impeller	1	C105-224DD	C105-224DD	-	-
12	Impeller (Silicon Brass)	1	C105-224DG	C105-224DG	C105-224DF	C105-224DF
13	Gasket, Impeller	1	C20-100	C20-100	C20-100	C20-100
14	Washer, Impeller	1	C43-45SS	C43-45SS	C43-45SS	C43-45SS
15	Washer, Stat-O-Seal	1	C43-46	C43-46	C43-46	C43-46
16	Screw, Impeller 3/8-16x3/4"	1	U30-72SS	U30-72SS	U30-72SS	U30-72SS
17	Wear Ring Only	1	C23-40	C23-40	C23-40	C23-40
18	Volute Assembly (includes 18A & 20)	1	C201-174	C201-174D	C201-174	C201-174D
18A	Volute Assembly (Incl. 17 Only)	1	C101-167	C101-167D	C101-167	C101-167D
19	Capscrew 5/16-18x3/4"	4	U30-62ZP	U30-62ZP	U30-62ZP	U30-62ZP
20	Pipe Plug, 1/4" NPT, Hex Head	1	U78-941ZPV	U78-941ZPV	U78-941ZPV	U78-941ZPV
21	Stud, 3/8-16x1-1/4"	4	U30-22SS	U30-22SS	U30-22SS	U30-22SS
22	Nut, Hex 3/8x16	4	U36-38ZP	U36-38SSW	U36-38ZP	U36-38SSW
23	Pipe Plug, 1/4" NPT	1	U78-57SSS	U78-57SSS	U78-57SSS	U78-57SSS

Model numbers with a "3" in them indicate a 3-Phase motor.

Model numbers with a "2" in them indicate a 200V motor.

NOTE: C Series with different hydraulic numbers (CCMH-93) are older models that use different parts. Consult factory for older models.

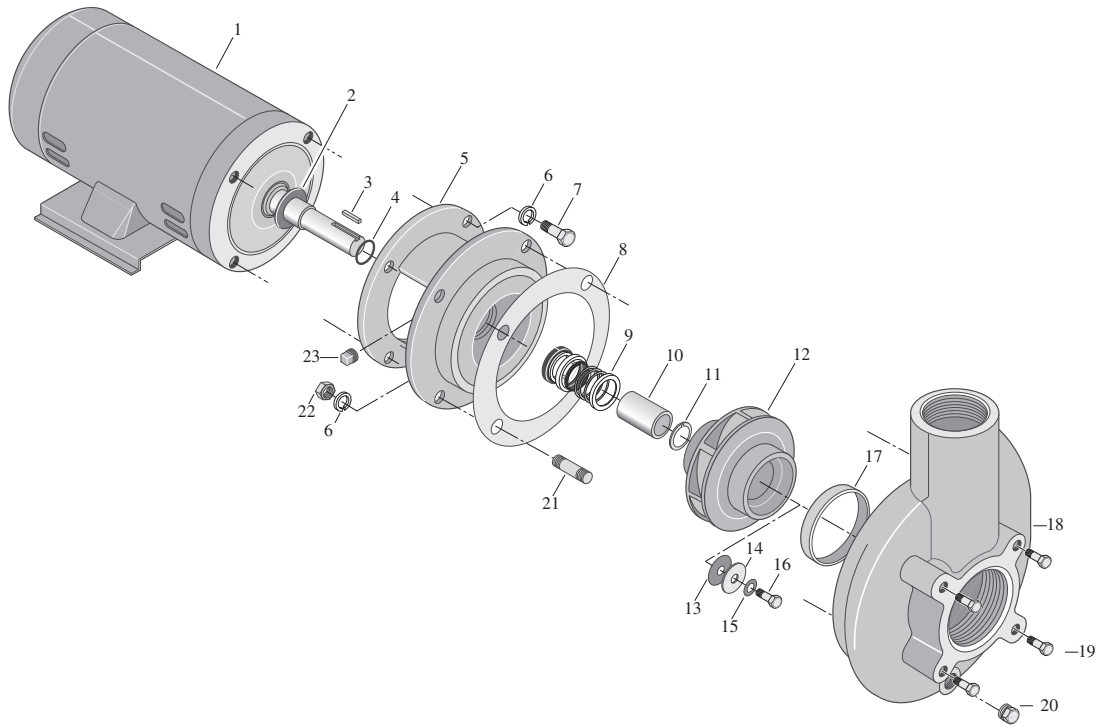

Key No.	Description	Qty.	CCHJ-138 CCHJ-138S CCHJ3-138S CCHJ36-138 CCH2J3-138S 5 HP	CHJ-138 CHJ3-138 CH2J3-138 5 HP
1	Motor 230V/60H/1 Ph.	1	C218-180	C218-180
1	Motor 230/460V/60H/3 Ph.	1	C218-182	C218-182
1	Motor 575V/60H/3 Ph.	1	C218-292C	-
1	Motor 200V/60H/3 Ph.	1	C218-181	C218-181
2	Water Slinger-3 Ph. (†)	1	C69-16	-
3	Key, Impeller	1	U65-42A	U65-42A
4	O-Ring	1	U9-265	U9-265
5	Adapter	1	C2-81	C2-81D
6	Lockwasher, 3/8"	8	U43-12ZP	U43-12ZP
7	Capscrew, 3/8-16x7/8"	4	U30-73ZP	U30-73ZP
8	Gasket	1	C20-77	C20-77
9	Shaft Seal	1	U109-433SS	U109-433SS
10	Shaft Sleeve	1	C23-58	C23-58
11	Gasket, Sleeve	1	C20-101	C20-101
12	Impeller (Silicon Brass)	1	C105-224DE	C105-224DE
13	Gasket, Impeller	1	C20-100	C20-100
14	Washer, Impeller	1	C43-45SS	C43-45SS
15	Washer, Stat-O-Seal	1	C43-46	C43-46
16	Screw, Impeller 3/8-16x3/4"	1	U30-72SS	U30-72SS
17	Wear Ring Only	1	C23-40	C23-40
18	Volute Assembly (includes 18A & 20)	1	C201-174	C201-174D
18A	Volute Assembly (Incl. 17 Only)	1	C101-167	C101-167D
19	Capscrew 5/16-18x3/4"	4	U30-62ZP	U30-62ZP
20	Pipe Plug, 1/4" NPT, Hex Head	1	U78-941ZPV	U78-941ZPV
21	Stud, 3/8-16x1-1/4"	4	U30-22SS	U30-22SS
22	Nut, Hex 3/8x16	4	U36-38ZP	U36-38SSW
23	Pipe Plug, 1/4" NPT	1	U78-57SSS	U78-57SSS

Model numbers with a "3" in them indicate a 3-Phase motor.

Model numbers with a "2" in them indicate a 200V motor.

(†) Model number CCH2J3-138S has no Water Slinger.

NOTE: C Series with different hydraulic numbers (CCMH-93) are older models that use different parts. Consult factory for older models.