

TYPE B CENTRIFUGAL PUMPS PUMP DIMENSIONS

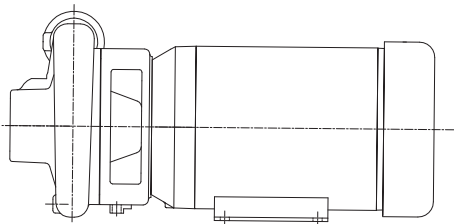

Motor Drive

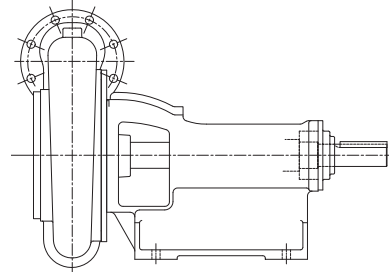

Frame Mount

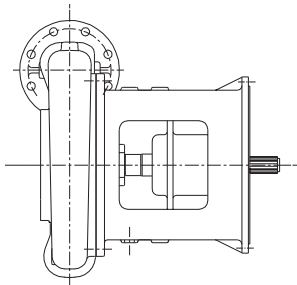

SAE Mount

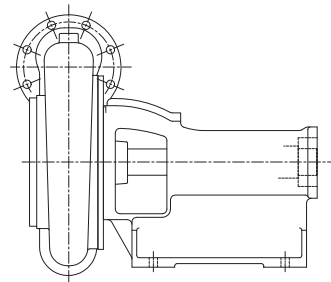

Hydraulic Drive

Table of Contents

Motor Drive Dimensions

NPT (Threaded)	2-4
Flanged (125 #ANSI)	5-7
Motor Frames	8

Frame Mount Dimensions

NPT (Threaded)	9-11
Flanged (125# ANSI)	12-13
Victaulic	14

Hydraulic Drive Dimensions

NPT (Threaded)	15
Flanged (125# ANSI)	15
Victaulic	15

SAE Mount Dimensions

NPT (Threaded)	16-18
Flanged (125# ANSI)	19-24
Victaulic	25

Motor Drive Dimensions

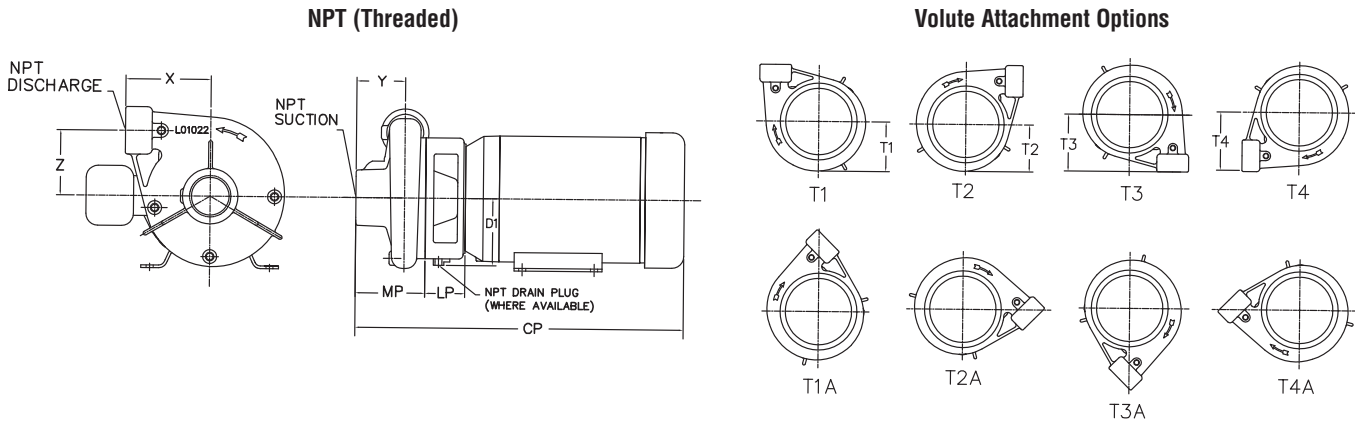

Note: Options T1A - T4A are rotated 45° from T1 - T4. Consult Factory for dimensions.

NPT (Threaded) – Single Stage

PUMP MODEL	SHAFT SEAL	RPM/ PHASE	FRAME GROUP*	SUCTION	DISCHARGE	X	Y	MP	LP	Z	T1	T2	T3	T4	D1†	CP (MAX)
B1WP	Packing	3600/1	C-1	1 1/2"	1"	5.00	2.50	4.19	5.44	4.12	4.94	4.94	5.00	5.06	5.25	23.80
		3600/3	C-1	1 1/2"	1"	5.00	2.50	4.19	6.69	4.12	4.94	4.94	5.00	5.06	5.25	25.05
B1WPS	Mechanical	3600/1	C-1	1 1/2"	1"	5.00	2.50	4.19	2.38	4.12	4.94	4.94	5.00	5.06		20.74
		3600/3	C-1	1 1/2"	1"	5.00	2.50	4.19	2.38	4.12	4.94	4.94	5.00	5.06		19.23
B1-1/2TPL	Packing	3600/1	C-1	2"	1-1/2"	5.38	2.69	4.25	5.56	3.81	4.25	4.06	5.38	5.25		22.65
		3600/3	C-1	2"	1-1/2"	5.38	2.69	4.25	5.56	3.81	4.25	4.06	5.38	5.25		21.47
B1-1/2TPLS	Mechanical	3600/1	C-1	2"	1-1/2"	5.38	2.69	4.25	2.50	3.81	4.25	4.06	5.38	5.25		19.59
		3600/3	C-1	2"	1-1/2"	5.38	2.69	4.25	2.50	3.81	4.25	4.06	5.38	5.25		17.98
B1-1/2TPM	Packing	3600/1	C-1	2"	1-1/2"	5.38	2.69	4.25	6.56	3.81	4.25	4.06	5.38	5.25		26.48
						5.38	2.69	4.25	5.56	3.81	4.25	4.06	5.38	5.25		25.48
		3600/3	C-1	2"	1-1/2"	5.38	2.69	4.25	5.56	3.81	4.25	4.06	5.38	5.25		23.87
B1-1/2TPMS	Mechanical	3600/1	C-1	2"	1-1/2"	5.38	2.69	4.25	2.50	3.81	4.25	4.06	5.38	5.25		22.42
		3600/3	C-1	2"	1-1/2"	5.38	2.69	4.25	2.50	3.81	4.25	4.06	5.38	5.25		20.81
B1-1/2ZPL	Packing	3600/1	C-1	2"	1-1/2"	5.38	2.88	4.50	6.69	5.06	5.06	5.94	5.38	6.25	5.25	26.86
		3600/3	C-1	2"	1-1/2"	5.38	2.88	4.50	5.44	5.06	5.06	5.94	5.38	6.25	5.25	25.50
B1-1/2ZPLS	Mechanical	3600/1	C-1	2"	1-1/2"	5.38	2.88	4.50	2.38	5.06	5.06	5.94	5.38	6.25		22.55
						5.38	2.88	4.50	3.75	5.06	5.06	5.94	5.38	6.25		25.42
		3600/3	C-1	2"	1-1/2"	5.38	2.88	4.50	2.38	5.06	5.06	5.94	5.38	6.25		22.44
B1-1/2ZPH	Packing	3600/3	C-1	2"	1-1/2"	5.38	2.88	4.50	6.69	5.06	5.06	5.94	5.38	6.25		26.75
			C-2	2"	1-1/2"	5.38	2.88	4.50	6.69	5.06	5.06	5.94	5.38	6.25		30.11
B1-1/2ZPHS	Mechanical	3600/3	C-1	2"	1-1/2"	5.38	2.88	4.50	2.38	5.06	5.06	5.94	5.38	6.25		22.44
			C-2	2"	1-1/2"	5.38	2.88	4.50	3.75	5.06	5.06	5.94	5.38	6.25		27.17
		1800/1	C-1	2"	1-1/2"	5.38	2.88	4.50	2.38	5.06	5.06	5.94	5.38	6.25		20.22
1801/3	C-1	2"	1-1/2"	5.38	2.88	4.50	2.38	5.06	5.06	5.94	5.38	6.25		18.11		
B1-1/2EPL	Packing	3600/3	C-2	2"	1-1/2"	6.50	2.63	4.19	6.25	5.69	6.19	6.63	6.50	6.94		29.36
B1-1/2EPLS	Mechanical	3600/3	C-2	2"	1-1/2"	6.50	2.63	4.19	3.38	5.69	6.19	6.63	6.50	6.94		26.49

NPT (Threaded) – Two Stage

PUMP MODEL	SHAFT SEAL	RPM/ PHASE	FRAME GROUP*	SUCTION	DISCHARGE	X	Y	MP	LP	Z	T1	T2	T3	T4	D1†	CP (MAX)
B1-1/2WP2S	Mechanical	3600 / 1	C-1	2"	1-1/2"	NA	1.78	6.13	3.69	7.44	NA	NA	NA	NA		23.50
						NA	1.78	6.13	3.69	7.44	NA	NA	NA	NA		24.63
		3600 / 3	C-1	2"	1-1/2"	NA	1.78	6.13	3.69	7.44	NA	NA	NA	NA		21.94
						NA	1.78	6.13	3.69	7.44	NA	NA	NA	NA		23.76
						NA	1.78	6.13	3.69	7.44	NA	NA	NA	NA		23.76

*See Motor Frame Size Chart.

† If Dimension "D1" is not referenced, no drain connection is available.



Motor Drive Dimensions

NPT (Threaded) – Single Stage

PUMP MODEL	SHAFT SEAL	RPM/ PHASE	FRAME GROUP*	SUCTION	DISCHARGE	X	Y	MP	LP	Z	T1	T2	T3	T4	D1†	CP (MAX)
B2TPM	Packing	3600/1	C-1	2 1/2"	2"	5.38	3.07	4.38	5.56	4.12	4.75	4.44	5.38	5.63		24.11
						5.38	3.07	4.38	6.56	4.12	4.75	4.44	5.38	5.63		26.61
		3600/3	C-1	2 1/2"	2"	5.38	3.07	4.38	5.56	4.12	4.75	4.44	5.38	5.63		22.60
						5.38	3.07	4.38	6.56	4.12	4.75	4.44	5.38	5.63		23.60
B2TPMS	Mechanical	3600/1	C-1	2 1/2"	2"	5.38	3.07	4.38	2.50	4.12	4.75	4.44	5.38	5.63		22.55
		3600/3	C-1	2 1/2"	2"	5.38	3.07	4.38	2.50	4.12	4.75	4.44	5.38	5.63		20.94
B2ZPL	Packing	3600/1	C-1	2 1/2"	2"	5.75	3.19	4.50	6.69	5.38	5.94	6.25	5.75	6.88		26.86
						5.75	3.19	4.50	6.69	5.38	5.94	6.25	5.75	6.88		26.75
		3600/3	C-2	2 1/2"	2"	5.75	3.19	4.50	6.69	5.38	5.94	6.25	5.75	6.88		28.36
B2ZPLS	Mechanical	3600/1	C-1	2 1/2"	2"	5.75	3.19	4.50	2.38	5.38	5.94	6.25	5.75	6.88		22.55
						5.75	3.19	4.50	2.38	5.38	5.94	6.25	5.75	6.88		22.44
		3600/3	C-2	2 1/2"	2"	5.75	3.19	4.50	3.75	5.38	5.94	6.25	5.75	6.88		25.42
B2ZPH	Packing	3600/3	C-2	2 1/2"	2"	5.75	3.19	4.50	6.69	5.38	5.94	6.25	5.75	6.88		30.25
B2ZPHS	Mechanical	3600/3	C-2	2 1/2"	2"	5.75	3.19	4.50	3.75	5.38	5.94	6.25	5.75	6.88		27.31
B2EPBL	Packing	3600/3	C-2	3"	2"	5.94	3.75	5.44	6.25	6.06	6.81	7.06	5.94	7.56		32.25
B2EPBLS	Mechanical	3600/3	C-2	3"	2"	5.94	3.75	5.44	3.38	6.06	6.81	7.06	5.94	7.56		29.38
B2EPBHH	Packing	3600/3	C-2	3"	2"	5.94	3.75	5.44	6.25	6.06	6.81	7.06	5.94	7.56		34.19
B2EPBHHS	Mechanical	3600/3	C-2	3"	2"	5.94	3.75	5.44	3.38	6.06	6.81	7.06	5.94	7.56		31.32
B2-1/2TPM	Packing	3600/1	C-1	3"	2 1/2"	5.88	3.56	4.88	5.56	4.25	4.94	6.50	6.25	7.25		23.28
						5.88	3.56	4.88	6.56	4.25	4.94	6.50	6.25	7.25		27.11
		3600/3	C-1	3"	2 1/2"	5.88	3.56	4.88	5.56	4.25	4.94	6.50	6.25	7.25		26.00
						5.88	3.56	4.88	6.56	4.25	4.94	6.50	6.25	7.25		27.00
		1800/1	C-1	3"	2 1/2"	5.88	3.56	4.88	5.56	4.25	4.94	6.50	6.25	7.25		22.28
1800/3	C-1	3"	2 1/2"	5.88	3.56	4.88	5.56	4.25	4.94	6.50	6.25	7.25		19.81		
B2-1/2TPMS	Mechanical	3600/1	C-1	3"	2 1/2"	5.88	3.56	4.88	2.50	4.25	4.94	6.50	6.25	7.25		23.05
		3600/3	C-1	3"	2 1/2"	5.88	3.56	4.88	2.50	4.25	4.94	6.50	6.25	7.25		22.94
		1800/1	C-1	3"	2 1/2"	5.88	3.56	4.88	2.50	4.25	4.94	6.50	6.25	7.25		19.22
		1800/3	C-1	3"	2 1/2"	5.88	3.56	4.88	2.50	4.25	4.94	6.50	6.25	7.25		17.25
B2-1/2ZPL	Packing	3600/3	C-1	3"	2 1/2"	6.25	3.68	5.18	6.69	4.25	4.94	6.50	6.25	7.25		27.43
			C-2	3"	2 1/2"	6.25	3.68	5.18	6.69	4.25	4.94	6.50	6.25	7.25		30.93
B2-1/2ZPLS	Mechanical	3600/3	C-1	3"	2 1/2"	6.25	3.68	5.18	2.38	4.25	4.94	6.50	6.25	7.25		23.12
			C-2	3"	2 1/2"	6.25	3.68	5.18	3.75	4.25	4.94	6.50	6.25	7.25		27.99
B2-1/2ZPM	Packing	1800/1	C-1	3"	2 1/2"	6.25	3.68	5.18	5.44	4.25	4.94	6.50	6.25	7.25	5.25	26.29
						6.25	3.68	5.18	6.69	4.25	4.94	6.50	6.25	7.25		27.54
		1800/3	C-1	3"	2 1/2"	6.25	3.68	5.18	5.44	4.25	4.94	6.50	6.25	7.25	5.25	24.68
						6.25	3.68	5.18	6.69	4.25	4.94	6.50	6.25	7.25		25.93
B2-1/2ZPMS	Mechanical	1800/1	C-1	3"	2 1/2"	6.25	3.68	5.18	2.38	4.25	4.94	6.50	6.25	7.25		23.23
		1800/3	C-1	3"	2 1/2"	6.25	3.68	5.18	2.38	4.25	4.94	6.50	6.25	7.25		21.62
B2-1/2JPBM	Packing	1800/3	C-2	4"	2 1/2"	6.50	4.38	6.75	5.44	7.81	8.56	8.94	6.50	9.75	8.00	31.25
B2-1/2JPBMS	Mechanical	1800/3	C-2	4"	2 1/2"	6.50	4.38	6.75	2.69	7.81	8.56	8.94	6.50	9.75		28.50
B3TPM	Packing	3600/1	C-1	4"	3"	7.00	3.50	4.94	6.56	4.56	5.38	5.00	7.00	6.75		27.17
						7.00	3.50	4.94	5.56	4.56	5.38	5.00	7.00	6.75		26.06
		3600/3	C-1	4"	3"	7.00	3.50	4.94	6.56	4.56	5.38	5.00	7.00	6.75		27.06
						7.00	3.50	4.94	6.56	4.56	5.38	5.00	7.00	6.75		28.67
		1800/1	C-1	4"	3"	7.00	3.50	4.94	5.56	4.56	5.38	5.00	7.00	6.75		23.84
1800/3	C-1	4"	3"	7.00	3.50	4.94	5.56	4.56	5.38	5.00	7.00	6.75		22.16		
B3TPMS	Mechanical	3600/1	C-1	4"	3"	7.00	3.50	4.94	2.50	4.56	5.38	5.00	7.00	6.75		23.11
						7.00	3.50	4.94	2.50	4.56	5.38	5.00	7.00	6.75		23.00
		3600/3	C-1	4"	3"	7.00	3.50	4.94	3.62	4.56	5.38	5.00	7.00	6.75		25.73
						7.00	3.50	4.94	3.62	4.56	5.38	5.00	7.00	6.75		19.28
		1800/3	C-1	4"	3"	7.00	3.50	4.94	2.50	4.56	5.38	5.00	7.00	6.75		18.67

*See Motor Frame Size Chart.

† If Dimension "D1" is not referenced, no drain connection is available.



Motor Drive Dimensions

NPT (Threaded) – Single Stage

PUMP MODEL	SHAFT SEAL	RPM/ PHASE	FRAME GROUP*	SUCTION	DISCHARGE	X	Y	MP	LP	Z	T1	T2	T3	T4	D1†	CP (MAX)
B3TPH	Packing	3600/3	C-2	4"	3"	7.00	3.50	4.94	6.56	4.56	5.38	5.00	7.00	6.75		30.42
		1800/1	C-1	4"	3"	7.00	3.50	4.94	5.56	4.56	5.38	5.00	7.00	6.75		23.84
		1800/3	C-1	4"	3"	7.00	3.50	4.94	5.56	4.56	5.38	5.00	7.00	6.75		22.16
B3TPHS	Mechanical	3600/3	C-2	4"	3"	7.00	3.50	4.94	3.62	4.56	5.38	5.00	7.00	6.75		27.48
		1800/1	C-1	4"	3"	7.00	3.50	4.94	2.50	4.56	5.38	5.00	7.00	6.75		20.78
		1800/3	C-1	4"	3"	7.00	3.50	4.94	2.50	4.56	5.38	5.00	7.00	6.75		18.67
B3ZPL	Packing	3600/3	C-2	4"	3"	7.00	3.63	5.38	6.69	5.88	6.94	6.50	6.25	9.75		33.07
B3ZPLS	Mechanical	3600/3	C-2	4"	3"	7.00	3.63	5.38	3.75	5.88	6.94	6.50	6.25	9.75		30.13
B3ZPM	Packing	1800/1	C-1	4"	3"	7.00	3.63	5.38	5.44	5.88	6.94	6.50	6.25	9.75	5.25	27.74
						7.00	3.63	5.38	6.69	5.88	6.94	6.50	6.25	9.75		28.99
		1800/3	C-1	4"	3"	7.00	3.63	5.38	5.44	5.88	6.94	6.50	6.25	9.75	5.25	26.38
			C-2	4"	3"	7.00	3.63	5.38	6.69	5.88	6.94	6.50	6.25	9.75		29.24
B3ZPMS	Mechanical	1800/1	C-1	4"	3"	7.00	3.63	5.38	2.38	5.88	6.94	6.50	6.25	9.75		24.68
						7.00	3.63	5.38	2.38	5.88	6.94	6.50	6.25	9.75		23.32
		1800/3	C-2	4"	3"	7.00	3.63	5.38	3.75	5.88	6.94	6.50	6.25	9.75		26.30
B3ZPBH	Packing	3600/3	C-2	4"	3"	7.00	3.63	5.38	6.69	5.88	6.75	7.00	7.00	8.06		34.57
B3ZPBHS	Mechanical	3600/3	C-2	4"	3"	7.00	3.63	5.38	3.75	5.88	6.75	7.00	7.00	8.06		31.63
			C-3	4"	3"	7.00	3.63	5.38	6.69	5.88	6.75	7.00	7.00	8.06		34.57
B3EPM	Packing	1800/1	C-1	4"	3"	8.62	4.31	6.25	6.25	6.50	7.44	6.94	8.62	9.88		29.42
						8.62	4.31	6.25	6.25	6.50	7.44	6.94	8.62	9.88		28.06
		1800/3	C-2	4"	3"	8.62	4.31	6.25	6.25	6.50	7.44	6.94	8.62	9.88		29.67
B3EPMS	Mechanical	1800/1	C-1	4"	3"	8.62	4.31	6.25	2.38	6.50	7.44	6.94	8.62	9.88		25.55
						8.62	4.31	6.25	2.38	6.50	7.44	6.94	8.62	9.88		24.19
		1800/3	C-2	4"	3"	8.62	4.31	6.25	3.38	6.50	7.44	6.94	8.62	9.88		26.80
B3EPBL	Packing	3600/3	C-2	4"	3"	8.62	4.31	6.25	6.81	6.50	7.44	6.94	8.62	9.88		35.56
			C-3	4"	3"	8.62	4.31	6.25	6.81	6.50	7.44	6.94	8.62	9.88		35.56
B3EPBLS	Mechanical	3600/3	C-2	4"	3"	8.62	4.31	6.25	3.38	6.50	7.44	6.94	8.62	9.88		32.13
			C-3	4"	3"	8.62	4.31	6.25	6.81	6.50	7.44	6.94	8.62	9.88		37.06
B3JPBL	Packing	1800/3	C-2	4"	3"	7.50	4.38	6.75	5.44	8.00	9.00	9.38	7.50	10.19	8.00	32.75
B3JPBLS	Mechanical	1800/3	C-2	4"	3"	7.50	4.38	6.75	2.69	8.00	9.00	9.38	7.50	10.19		30.00
B3JPBM	Packing	1800/3	C-2	4"	3"	7.50	4.38	6.75	5.44	8.00	9.00	9.38	7.50	10.19	8.00	33.19
B3JPBMS	Mechanical	1800/3	C-2	4"	3"	7.50	4.38	6.75	2.69	8.00	9.00	9.38	7.50	10.19		30.44

*See Motor Frame Size Chart.

† If Dimension "D1" is not referenced, no drain connection is available.



Motor Drive Dimensions

FLANGED (125# ANSI)

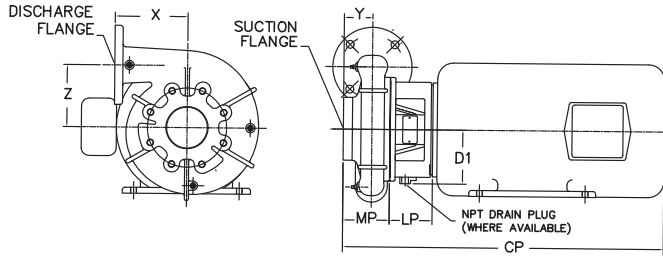

Volute Attachment Options

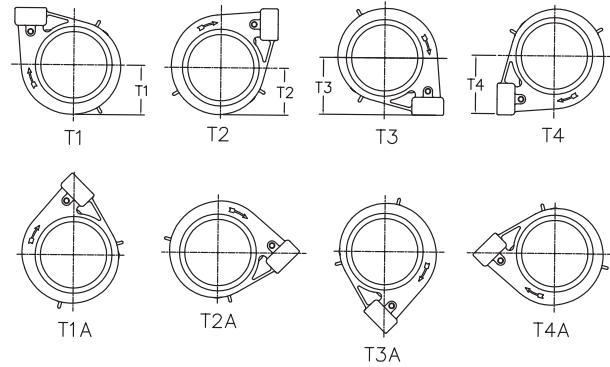

Note: Options T1A - T4A are rotated 45° from T1 - T4.
Consult Factory for dimensions.

FLANGED (125# ANSI)

PUMP MODEL	SHAFT SEAL	RPM/PHASE	FRAME GROUP*	SUCTION**	DISCHARGE**	X	Y	MP	LP	Z	T1	T2	T3	T4	D1†	CP (MAX)
B2TPM	Packing	3600/1	C-1	2.50"	2.00"	6.50	3.51	4.81	5.56	4.75	4.73	4.58	6.50	7.75		26.04
						6.50	3.51	4.81	6.56	4.75	4.73	4.58	6.50	7.75		28.29
		3600/3	C-1	2.50"	2.00"	6.50	3.51	4.81	5.56	4.75	4.73	4.58	6.50	7.75		24.43
						6.50	3.51	4.81	6.56	4.75	4.73	4.58	6.50	7.75		25.43
B2TPMS	Mechanical	3600/1	C-1	2.50"	2.00"	6.50	3.51	4.81	2.50	4.75	4.73	4.58	6.50	7.75		22.98
		3600/3	C-1	2.50"	2.00"	6.50	3.51	4.81	2.50	4.75	4.73	4.58	6.50	7.75		21.37
B2ZPL	Packing	3600/1	C-1	2.50"	2.00"	7.00	4.00	5.31	6.69	5.88	6.32	6.00	7.00	8.88		27.67
		3600/3	C-1	2.50"	2.00"	7.00	4.00	5.31	6.69	5.88	6.32	6.00	7.00	8.88		27.56
			C-2	2.50"	2.00"	7.00	4.00	5.31	6.69	5.88	6.32	6.00	7.00	8.88		29.17
B2ZPLS	Mechanical	3600/1	C-1	2.50"	2.00"	7.00	4.00	5.31	2.38	5.88	6.32	6.00	7.00	8.88		23.36
		3600/3	C-1	2.50"	2.00"	7.00	4.00	5.31	2.38	5.88	6.32	6.00	7.00	8.88		23.25
			C-2	2.50"	2.00"	7.00	4.00	5.31	3.75	5.88	6.32	6.00	7.00	8.88		26.23
B2ZPHS	Mechanical	3600/3	C-2	2.50"	2.00"	7.00	4.00	5.31	3.75	5.88	6.32	6.00	7.00	8.88		28.12
B2EPBL	Packing	3600/3	C-2	3.00"	2.00"	8.00	5.50	7.19	6.25	6.50	6.91	6.59	8.00	9.50		34.00
B2EPBLS	Mechanical	3600/3	C-2	3.00"	2.00"	8.00	5.50	7.19	3.38	6.50	6.91	6.59	8.00	9.50		31.13
B2EPBHHS	Mechanical	3600/3	C-2	3.00"	2.00"	8.00	5.50	7.19	3.38	6.50	6.91	6.59	8.00	9.50		33.07
B2-1/2TPM	Packing	3600/1	C-1	3.00"	2.50"	6.00	4.25	5.56	5.56	4.69	5.05	4.74	6.00	8.19		23.96
						6.00	4.25	5.56	6.56	4.69	5.05	4.74	6.00	8.19		27.79
		3600/3	C-1	3.00"	2.50"	6.00	4.25	5.56	5.56	4.69	5.05	4.74	6.00	8.19		26.68
						6.00	4.25	5.56	6.56	4.69	5.05	4.74	6.00	8.19		27.68
B2-1/2TPMS	Mechanical	1800/1	C-1	3.00"	2.50"	6.00	4.25	5.56	5.56	4.69	5.05	4.74	6.00	8.19		22.96
		1800/3	C-1	3.00"	2.50"	6.00	4.25	5.56	5.56	4.69	5.05	4.74	6.00	8.19		20.49
		3600/1	C-1	3.00"	2.50"	6.00	4.25	5.56	2.50	4.69	5.05	4.74	6.00	8.19		23.73
		3600/3	C-1	3.00"	2.50"	6.00	4.25	5.56	2.50	4.69	5.05	4.74	6.00	8.19		23.62
B2-1/2ZPLS (All w/bronze wear ring)	Mechanical	3600/3	C-1	3.00"	2.50"	6.00	4.25	5.56	2.50	4.69	5.05	4.74	6.00	8.19		19.90
			C-1	3.00"	2.50"	6.00	4.25	5.56	2.50	4.69	5.05	4.74	6.00	8.19		17.93
				C-2	3.00"	2.50"	6.75	4.00	5.50	3.75	6.00	6.48	9.21	6.75	9.50	
						6.75	4.00	5.50	3.75	6.00	6.48	9.21	6.75	9.50		28.31

*See Motor Frame Size Chart.

**125# ANSI.

† If Dimension "D1" is not referenced, no drain connection is available.



Motor Drive Dimensions

FLANGED (125# ANSI)

PUMP MODEL	SHAFT SEAL	RPM/ PHASE	FRAME GROUP*	SUCTION**	DISCHARGE**	X	Y	MP	LP	Z	T1	T2	T3	T4	D1†	CP (MAX)
B2-1/2ZPM	Packing	1800/1	C-1	3.00"	2.50"	6.75	4.00	5.50	5.44	6.00	6.48	9.21	6.75	9.50	5.25	26.61
						6.75	4.00	5.50	6.69	6.00	6.48	9.21	6.75	9.50		27.86
		1800/3	C-1	3.00"	2.50"	6.75	4.00	5.50	5.44	6.00	6.48	9.21	6.75	9.50	5.25	25.00
						6.75	4.00	5.50	6.69	6.00	6.48	9.21	6.75	9.50		26.25
B2-1/2ZPMS	Mechanical	1800/1	C-1	3.00"	2.50"	6.75	4.00	5.50	2.38	6.00	6.48	9.21	6.75	9.50		23.55
		1800/3	C-1	3.00"	2.50"	6.75	4.00	5.50	2.38	6.00	6.48	9.21	6.75	9.50		21.94
B3TPM	Packing	3600/1	C-1	4.00"	3.00"	6.88	2.56	4.00	6.56	4.56	5.38	5.00	7.00	6.75		26.23
						6.88	2.56	4.00	5.56	4.56	5.38	5.00	7.00	6.75	25.12	
		3600/3	C-1	4.00"	3.00"	6.88	2.56	4.00	6.56	4.56	5.38	5.00	7.00	6.75		26.12
						6.88	2.56	4.00	6.56	4.56	5.38	5.00	7.00	6.75	27.73	
		1800/1	C-1	4.00"	3.00"	6.88	2.56	4.00	5.56	4.56	5.38	5.00	7.00	6.75		22.90
		1800/3	C-1	4.00"	3.00"	6.88	2.56	4.00	5.56	4.56	5.38	5.00	7.00	6.75		21.22
B3TPMS	Mechanical	3600/1	C-1	4.00"	3.00"	6.88	2.56	4.00	2.50	4.56	5.38	5.00	7.00	6.75		22.17
		3600/3	C-1	4.00"	3.00"	6.88	2.56	4.00	2.50	4.56	5.38	5.00	7.00	6.75		22.06
			C-2	4.00"	3.00"	6.88	2.56	4.00	3.62	4.56	5.38	5.00	7.00	6.75		24.79
		1800/1	C-1	4.00"	3.00"	6.88	2.56	4.00	2.50	4.56	5.38	5.00	7.00	6.75		19.84
B3TPH	Packing	3600/3	C-2	4.00"	3.00"	6.88	2.56	4.00	6.56	4.56	5.38	5.00	7.00	6.75		29.48
		1800/1	C-1	4.00"	3.00"	6.88	2.56	4.00	5.56	4.56	5.38	5.00	7.00	6.75		22.90
B3TPHS	Mechanical	3600/3	C-2	4.00"	3.00"	6.88	2.56	4.00	3.62	5.38	5.00	7.00	6.75	6.75		26.54
		1800/1	C-1	4.00"	3.00"	6.88	2.56	4.00	2.50	4.56	5.38	5.00	7.00	6.75		19.84
B3TPHH	Packing	3600/3	C-2	4.00"	3.00"	6.88	2.56	4.00	6.56	4.56	5.38	5.00	6.88	8.31		29.48
		1800/3	C-1	4.00"	3.00"	6.88	2.56	4.00	5.56	4.56	5.38	5.00	7.00	6.75		17.73
B3TPHHS	Mechanical	3600/3	C-2	4.00"	3.00"	6.88	2.56	4.00	3.62	4.56	5.38	5.00	6.88	8.31		26.54
B3ZPL	Packing	3600/3	C-2	4.00"	3.00"	6.88	2.68	4.40	6.69	5.88	5.38	5.00	7.00	6.75		32.09
B3ZPLS	Mechanical	3600/3	C-2	4.00"	3.00"	6.88	2.68	4.40	3.75	5.88	5.38	5.00	7.00	6.75		29.15
B3ZPM	Packing	1800/1	C-1	4.00"	3.00"	6.88	2.68	4.40	5.44	5.88	5.38	5.00	7.00	6.75	5.25	26.76
						6.88	2.68	4.40	6.69	5.88	5.38	5.00	7.00	6.75	28.01	
		1800/3	C-1	4.00"	3.00"	6.88	2.68	4.40	5.44	5.88	5.38	5.00	7.00	6.75	5.25	25.40
						6.88	2.68	4.40	6.69	5.88	5.38	5.00	7.00	6.75	28.26	
B3ZPMS	Mechanical	1800/1	C-1	4.00"	3.00"	6.88	2.68	4.40	2.38	5.88	5.38	5.00	7.00	6.75		23.70
		1800/3	C-1	4.00"	3.00"	6.88	2.68	4.40	2.38	5.88	5.38	5.00	7.00	6.75		22.34
B3ZPBH	Packing		3600/3	C-2	4.00"	3.00"	6.88	2.68	4.40	3.75	5.88	5.38	5.00	7.00	6.75	25.32
		6.88														
B3ZPBHS	Mechanical	3600/3	C-2	4.00"	3.00"	6.88	2.68	4.40	3.75	5.88	6.78	6.31	6.88	9.63	30.65	
																6.88
B3EPBLS	Mechanical	3600/3	C-2	4.00"	3.00"	9.50	5.50	7.50	3.38	7.38	7.47	7.02	9.50	11.12	33.38	
																9.50
B4EPBM	Packing	3600/3	C-2	5.00"	4.00"	8.00	2.50	4.69	6.81	6.68	7.81	7.25	8.00	11.19	34.00	
																8.00
B4EPBMS	Mechanical	3600/3	C-2	5.00"	4.00"	8.00	2.50	4.69	3.38	6.68	7.81	7.25	8.00	11.19	30.57	
																8.00
B4EPM	Packing	1800/3	C-2	5.00"	4.00"	8.00	2.50	4.69	6.25	6.68	7.81	7.25	8.00	11.19		29.86
B4EPMS	Mechanical	1800/3	C-2	5.00"	4.00"	8.00	2.50	4.69	3.38	6.68	7.81	7.25	8.00	11.19		26.99
B4JPBH	Packing	1800/3	C-2	5.00"	4.00"	9.00	2.62	5.00	5.44	8.56	9.31	9.75	9.00	12.50	8.00	32.94
B4JPBHS	Mechanical	1800/3	C-2	5.00"	4.00"	9.00	2.62	5.00	2.69	8.56	9.31	9.75	9.00	12.50		30.19
B4JPBHH	Packing	1800/3	C-3	5.00"	4.00"	9.00	2.62	5.00	5.88	8.56	9.31	9.75	9.00	12.50	8.00	33.88
B4JPBHHS	Mechanical	1800/3	C-3	5.00"	4.00"	9.00	2.62	5.00	5.88	8.56	9.31	9.75	9.00	12.50	8.00	33.88
B4EXPBL	Packing	1800/3	C-3	5.00"	4.00"	9.38	3.38	5.81	6.94	9.50	11.62	11.25	9.38	14.00		36.75
B4EYPBM	Packing	1800/3	C-2	5.00"	4.00"	12.00	5.25	7.63	5.44	10.50	12.81	12.25	12.00	15.00	8.00	35.57
						12.00	5.25	7.63	5.88	10.50	12.81	12.25	12.00	15.00	8.00	39.01
B4EYPBMS	Mechanical	1800/3	C-2	5.00"	4.00"	12.00	5.25	7.63	2.69	10.50	12.81	12.25	12.00	15.00		32.82
						12.00	5.25	7.63	5.88	10.50	12.81	12.25	12.00	15.00	8.00	39.01
B4EYPBH	Packing	1800/3	C-3	5.00"	4.00"	12.00	5.25	7.63	5.88	10.50	12.81	12.25	12.00	15.00	8.00	40.51

*See Motor Frame Size Chart.

**125# ANSI.

† If Dimension "D1" is not referenced, no drain connection is available.



Motor Drive Dimensions

FLANGED (125# ANSI)

PUMP MODEL	SHAFT SEAL	RPM/PHASE	FRAME GROUP*	SUCTION**	DISCHARGE**	X	Y	MP	LP	Z	T1	T2	T3	T4	D1†	CP (MAX)	
B4GPBH (with 6" suction reducer attached)	Packing	1800/3	C-2	5.00"	4.00"	9.88	3.64	6.15	5.44	8.25	9.75	9.00	9.88	12.75	8.00	34.09	
		1800/3	C-2	6.00"	4.00"	9.88	3.64	14.15	5.44	8.25	9.75	9.00	9.88	12.75	8.00	42.09	
B4GPBHS (with 6" suction reducer attached)	Mechanical	1800/3	C-2	5.00"	4.00"	9.88	3.64	6.15	2.69	8.25	9.75	9.00	9.88	12.75		31.34	
		1800/3	C-2	6.00"	4.00"	9.88	3.64	14.15	2.69	8.25	9.75	9.00	9.88	12.75		39.34	
B5EPBM	Packing	3600/3	C-2	6.00"	5.00"	9.50	3.94	6.56	6.81	6.94	8.26	7.61	9.50	11.94		35.87	
			C-3	6.00"	5.00"	9.50	3.94	6.56	6.81	6.94	8.26	7.61	9.50	11.94		40.37	
B5EPBMS	Mechanical	3600/3	C-2	6.00"	5.00"	9.50	3.94	6.56	3.38	6.94	8.26	7.61	9.50	11.94		32.44	
			C-3	6.00"	5.00"	9.50	3.94	6.56	6.81	6.94	8.26	7.61	9.50	11.94		40.37	
B5EPH	Packing	1800/3	C-2	6.00"	5.00"	9.50	3.94	6.56	6.25	6.94	8.26	7.61	9.50	11.94		31.87	
B5EPHS	Mechanical	1800/3	C-2	6.00"	5.00"	9.50	3.94	6.56	3.38	6.94	8.26	7.61	9.50	11.94		30.52	
B5EXPBH	Packing	1800/3	C-3	6.00"	5.00"	10.25	3.00	5.75	6.94	9.75	12.25	11.63	10.25	14.75		39.69	
B5EXPBHS	NA	NA	NA	NA	NA	NA	NA	NA	NA	NA	NA	NA	NA	NA	NA	NA	
B5WP	Packing	1800/1	C-1	6.00"	5.00"	7.00	5.19	7.43	5.00	6.25	7.50	6.66	7.00	11.25	5.00	28.10	
		1800/3	C-1	6.00"	5.00"	7.00	5.19	7.43	5.00	6.25	7.50	6.66	7.00	11.25	5.00	27.99	
B5WPS	Mechanical	1800/1	C-1	6.00"	5.00"	7.00	5.19	7.43	5.00	6.25	7.50	6.66	7.00	11.25	5.00	29.35	
		1800/3	C-1	6.00"	5.00"	7.00	5.19	7.43	5.00	6.25	7.50	6.66	7.00	11.25	5.00	27.99	
B6ZPL	Packing	1800/1	C-1	8.00"	6.00"	8.00	4.00	7.12	6.69	7.31	8.92	7.67	8.00	12.81		30.73	
		1800/3	C-1	8.00"	6.00"	8.00	4.00	7.12	6.69	7.31	8.92	7.67	8.00	12.81		29.37	
			C-2	8.00"	6.00"	8.00	4.00	7.12	6.69	7.31	8.92	7.67	8.00	12.81		32.73	
B6ZPLS	Mechanical	1800/1	C-1	8.00"	6.00"	8.00	4.00	7.12	2.38	7.31	8.92	7.67	8.00	12.81		26.42	
		1800/3	C-1	8.00"	6.00"	8.00	4.00	7.12	2.38	7.31	8.92	7.67	8.00	12.81		25.06	
			C-2	8.00"	6.00"	8.00	4.00	7.12	3.75	7.31	8.92	7.67	8.00	12.81		29.79	
B6ZPH	Packing	1800/3	C-2	8.00"	6.00"	8.00	4.00	7.12	6.69	7.31	8.92	7.67	8.00	12.81		34.37	
B6ZPHS	Mechanical	1800/3	C-2	8.00"	6.00"	8.00	4.00	7.12	3.75	7.31	8.92	7.67	8.00	12.81		31.43	
B6JPBL	Packing	1800/3	C-2	8.00"	6.00"	11.00	3.00	5.88	5.44	8.75	9.97	9.16	11.00	14.25	8.00	33.82	
B6JPBLS	Mechanical	1800/3	C-2	8.00"	6.00"	11.00	3.00	5.88	2.69	8.75	9.97	9.16	11.00	14.25		31.07	
B6JPBM	Packing	1800/3	C-2	8.00"	6.00"	11.00	3.00	5.88	5.44	8.75	9.97	9.16	11.00	14.25	8.00	33.82	
			C-3	8.00"	6.00"	11.00	3.00	5.88	5.88	8.75	9.97	9.16	11.00	14.25	8.00	35.76	
			1200/3	C-2	8.00"	6.00"	11.00	3.00	5.88	5.44	8.75	9.97	9.16	11.00	14.25	8.00	
B6JPBMS	Mechanical	1800/3	C-2	8.00"	6.00"	11.00	3.00	5.88	2.69	8.75	9.97	9.16	11.00	14.25		31.07	
			C-3	8.00"	6.00"	11.00	3.00	5.88	2.69	8.75	9.97	9.16	11.00	14.25	8.00	31.57	
			1200/3	C-2	8.00"	6.00"	11.00	3.00	5.88	2.69	8.75	9.97	9.16	11.00	14.25		29.13
B6JPBH	Packing	1800/3	C-3	8.00"	6.00"	11.00	3.88	6.75	5.88	8.75	10.50	9.94	11.00	14.25	8.00	38.13	
B6JPBHS	Mechanical	1800/3	C-3	8.00"	6.00"	11.00	3.88	6.75	5.88	8.75	10.50	9.94	11.00	14.25	8.00	38.13	
B6EXPBL	Packing	1800/3	C-3	8.00"	6.00"	10.19	4.12	7.19	5.12	10.00	12.81	11.94	12.94	16.38	6.31	37.81	
B6EXPBLS	Mechanical	1800/3	C-3	8.00"	6.00"	10.19	4.12	7.19	5.12	10.00	12.81	11.94	12.94	16.38	6.31	37.81	
B6EXPBH	Packing	1800/3	C-3	8.00"	6.00"	10.19	4.12	7.19	5.12	10.00	12.81	11.94	12.94	16.38	6.31	39.31	
			C-4	8.00"	6.00"	10.19	4.12	7.19	5.12	10.00	12.81	11.94	12.94	16.38	6.31	43.81	
B6EXPBHS	Mechanical	1800/3	C-3	8.00"	6.00"	10.19	4.12	7.19	5.12	10.00	12.81	11.94	12.94	16.38	6.31	39.31	
			C-4	8.00"	6.00"	10.19	4.12	7.19	5.12	10.00	12.81	11.94	12.94	16.38	6.31	43.81	
B8GPBM	Packing	1800/3	C-2	10.00"	8.00"	12.75	4.00	7.38	5.44	9.88	12.44	11.12	12.75	16.63	8.00	35.32	
			C-3	10.00"	8.00"	12.75	4.00	7.38	5.88	9.88	12.44	11.12	12.75	16.63	8.00	40.26	
		1200/3	C-2	10.00"	8.00"	12.75	4.00	7.38	5.44	9.88	12.44	11.12	12.75	16.63	8.00	35.32	
			C-3	10.00"	8.00"	12.75	4.00	7.38	5.88	9.88	12.44	11.12	12.75	16.63	8.00	36.26	
B8GPBMS	Mechanical	1800/3	C-2	10.00"	8.00"	12.75	4.00	7.38	2.69	9.88	12.44	11.12	12.75	16.63		32.57	
			C-3	10.00"	8.00"	12.75	4.00	7.38	5.88	9.88	12.44	11.12	12.75	16.63	8.00	40.26	
		1200/3	C-2	10.00"	8.00"	12.75	4.00	7.38	5.44	9.88	12.44	11.12	12.75	16.63		35.32	
			C-3	10.00"	8.00"	12.75	4.00	7.38	5.88	9.88	12.44	11.12	12.75	16.63	8.00	36.26	
B10GPBM	Packing	1800/3	C-3	12.00"	10.00"	12.88	4.38	8.50	5.88	9.63	11.69	10.00	14.88	17.25	8.00	41.38	
			C-2	12.00"	10.00"	12.88	4.38	8.50	5.44	9.63	11.69	10.00	14.88	17.25	8.00	36.44	
			C-3	12.00"	10.00"	12.88	4.38	8.50	5.44	9.63	11.69	10.00	14.88	17.25	8.00	36.94	
B10GPBMS	Mechanical	1800/3	C-3	12.00"	10.00"	12.88	4.38	8.50	5.88	9.63	11.69	10.00	14.88	17.25	8.00	41.38	
		1200/3	C-2	12.00"	10.00"	12.88	4.38	8.50	2.69	9.63	11.69	10.00	14.88	17.25		33.69	
			C-3	12.00"	10.00"	12.88	4.38	8.50	2.69	9.63	11.69	10.00	14.88	17.25		34.19	

*See Motor Frame Size Chart.

**125# ANSI.

† If Dimension "D1" is not referenced, no drain connection is available.



Motor Drive Dimensions – Motor Frames

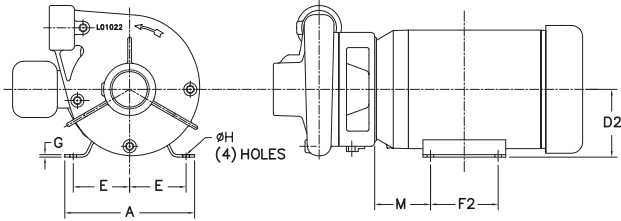

NPT (Threaded)

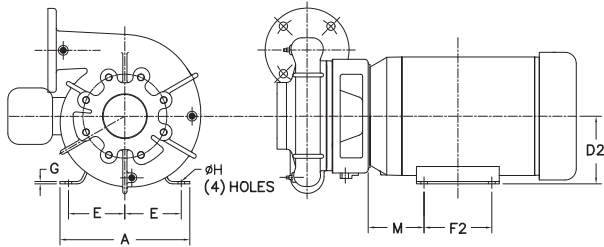

FLANGED (125# ANSI)

Single Phase – NEMA “C” Face Type Motors, Drip Proof Close Coupled

HORSEPOWER			TCZ, JM, and JP FRAMES
1200 RPM	1800 RPM	3600 RPM	
NA	1	1.5	143
NA	1.5	2	145
1	2	3	182
1.5	3	5	184
2	5	7.5	213
3	7.5 & 10	10	215

Three Phase

NA	1	1.5	143
NA	1.5	2	145
1	2	3	145
1.5	3	5	182
2	5	7.5	184
3	7.5	10	213
5	10	15	215
7.5	15	20	254
10	20	25	256
20	25	30	284
25	30	40	286
30	40	50	324
40	50	60	326
50	60	75	364 TY
NA	75	100	365 TY
NA	100	125	404 TY
NA	125	150	405 TY
NA	150	NA	444 TY

All dimensions shown in inches

FRAME SIZE	FRAME GROUP	A	D2	E	F2	G	H	M
143 TCZ & JP/JM	C-1	7.00	3.50	2.75	4.00	0.25	0.34	2.75
145 TCZ & JP/JM		7.00	3.50	2.75	5.00	0.25	0.34	2.75
182 JP/JM		9.00	4.50	3.75	4.50	0.44	0.41	3.38
182 TCZ		9.00	4.50	3.75	4.50	0.44	0.41	3.38
184 JP/JM		9.00	4.50	3.75	5.50	0.44	0.41	3.38
184 TCZ		9.00	4.50	3.75	5.50	0.44	0.41	3.38
213 JP/JM		10.50	5.25	4.25	5.50	0.50	0.41	4.25
213 TCZ		10.50	5.25	4.25	5.50	0.50	0.41	4.25
215 JP/JM		10.50	5.25	4.25	7.00	0.50	0.41	4.25
215 TCZ		10.50	5.25	4.25	7.00	0.50	0.41	4.25
254 TCZ & JP/JM	C-2	12.38	6.25	5.00	8.25	0.75	0.53	4.75
256 TCZ		12.38	6.25	5.00	10.00	0.75	0.53	4.75
284 JP/JM		13.88	7.00	5.50	9.50	0.75	0.53	4.75
284 TCZ		13.88	7.00	5.50	9.50	0.75	0.53	4.75
286 JP/JM		13.88	7.00	5.50	11.00	0.75	0.53	4.75
286 TCZ		13.88	7.00	5.50	11.00	0.75	0.53	4.75
324 TCZ & JP/JM	C-2	15.88	8.00	6.25	10.50	0.88	0.66	5.25
326 TCZ & JP/JM		15.88	8.00	6.25	12.00	0.88	0.66	5.25
364 JP	C-3	17.75	9.00	7.00	11.25	1.00	0.66	5.88
364 TY		17.75	9.00	7.00	11.25	1.00	0.66	6.88
365 JP		17.75	9.00	7.00	12.25	1.00	0.66	5.88
365 TY		17.75	9.00	7.00	12.75	1.00	0.66	6.88
404 TY		19.75	10.00	8.00	12.25	1.13	0.81	7.63
405 TY		19.75	10.00	8.00	13.75	1.13	0.81	7.63
444 TY	C-4	21.75	11.00	9.00	14.50	1.38	0.81	7.50
445 TY		21.75	11.00	9.00	16.50	1.38	0.81	7.50

Note: Frame sizes 143 TC and 145 TCZ, 254 TC and 256 TC, 324 TC and 326 TC, are interchangeable with JP frames. All other frame sizes are not interchangeable.

Frame Mount Dimensions

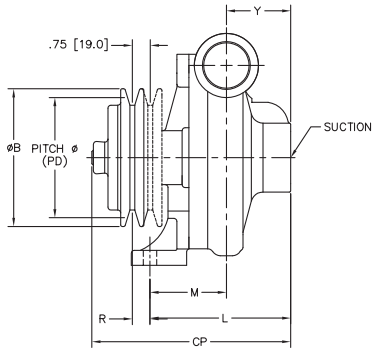

FIGURE 1

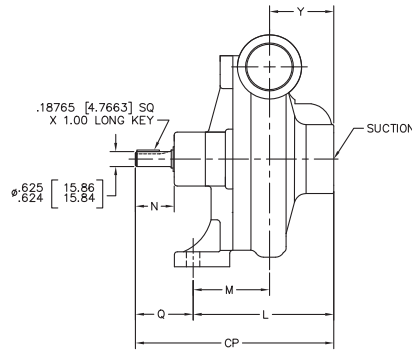

FIGURE 2

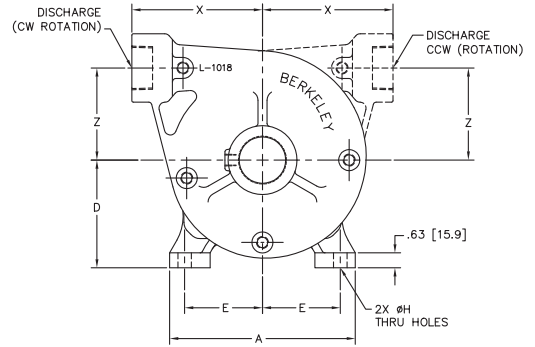

FIGURE 3

NPT Belt Drive (Figs. 1 & 3)

PUMP MODEL	ROT	NPT SUCTION	NPT DISCHARGE	A	D	E	H	L	M	X	Y	Z	R	CP	# OF GROOVES	BELT SECT.	PD	B
B1MRS	CCW	1.25"	1.00"	6.34	3.44	2.62	0.44	4.32	1.94	4.56	2.38	3.00	1.09	7.16	1	A	2.90	3.20
B1XRS	CCW	1.25"	1.00"	6.34	3.44	2.62	0.44	4.81	2.28	4.56	2.53	3.00	1.03	7.65	1	A/B	3.20/3.60	4.00
B1XRMS	CCW	1.25"	1.00"	6.34	3.44	2.62	0.44	4.81	2.28	4.56	2.53	3.00	1.03	7.65	1	A/B	3.20/3.60	4.00
B1-1/2MRS	CW	2.00"	1.50"	6.17	3.44	2.62	0.44	4.69	2.19	5.00	2.50	2.19	1.04	7.54	1	A/B	3.20/3.60	4.00
B1-1/2TRLS	CW	2.00"	1.50"	7.75	4.50	3.25	0.56	5.87	3.18	5.38	2.69	3.81	0.67	8.29	2	A/B	5.00/5.40	5.75
B2TRMS	CW	2.50"	2.00"	7.75	4.50	3.25	0.56	6.00	2.93	5.38	3.07	4.12	0.67	8.42	2	A/B	5.00/5.40	5.75
B2-1/2TRMS	CW	3.00"	2.50"	7.75	4.50	3.25	0.56	6.50	5.19	5.88	1.31	4.25	0.67	8.92	2	A/B	5.00/5.40	5.75
B3TRMS	CW	4.00"	3.00"	7.75	4.50	3.25	0.56	6.56	5.12	7.00	1.44	4.56	0.67	8.98	2	A/B	5.00/5.40	5.75

NPT Coupling Drive (Figs. 2 & 3)

PUMP MODEL	ROT	NPT SUCTION	NPT DISCHARGE	A	D	E	H	L	M	X	Y	Z	N	Q	CP	KEY
B1MRS	CCW	1.25"	1.00"	6.34	3.44	2.62	0.44	4.32	1.94	4.56	2.38	3.00	1.72	2.84	7.16	1.8765 sq x 1.00 long
B1XRS	CCW	1.25"	1.00"	6.34	3.44	2.62	0.44	4.81	2.28	4.56	2.53	3.00	1.72	2.84	7.65	1.8765 sq x 1.00 long
B1XRMS	CCW	1.25"	1.00"	6.34	3.44	2.62	0.44	4.81	2.28	4.56	2.53	3.00	1.72	2.84	7.65	1.8765 sq x 1.00 long
B1-1/2MRS	CW	2.00"	1.50"	6.17	3.44	2.62	0.44	4.69	2.19	5.00	2.50	2.19	1.60	2.85	7.54	1.8765 sq x 1.00 long
B1-1/2TRLS	CW	2.00"	1.50"	7.75	4.50	3.25	0.56	5.87	3.18	5.38	2.69	3.81	1.64	2.42	8.29	1.8765 sq x 1.00 long
B2TRMS	CW	2.50"	2.00"	7.75	4.50	3.25	0.56	6.00	2.93	5.38	3.07	4.12	1.64	2.42	8.42	1.8765 sq x 1.00 long
B2-1/2TRMS	CW	3.00"	2.50"	7.75	4.50	3.25	0.56	6.50	5.19	5.88	1.31	4.25	1.64	2.42	8.92	1.8765 sq x 1.00 long
B3TRMS	CW	4.00"	3.00"	7.75	4.50	3.25	0.56	6.56	5.12	7.00	1.44	4.56	1.64	2.42	8.98	1.8765 sq x 1.00 long

Frame Mount Dimensions

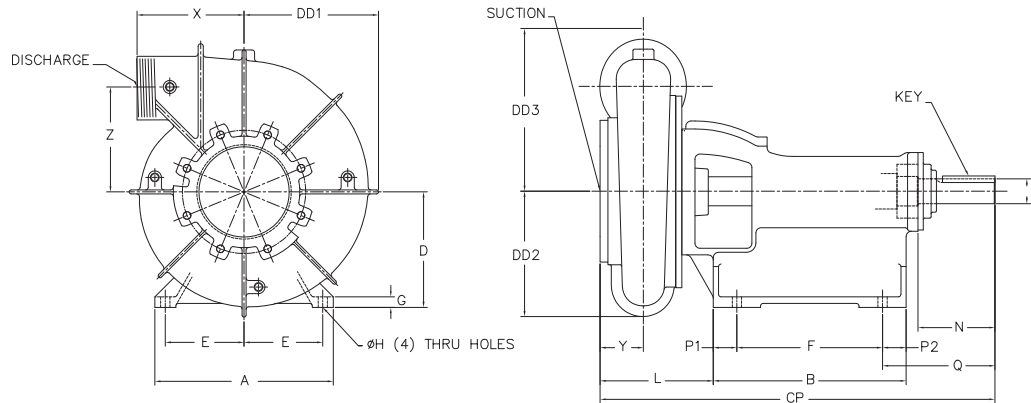

NPT (Threaded)

	PUMP MODEL	SHAFT SEAL	ROT	SUCTION	DISCHARGE	A	B	D	E	F	G	H	L	N	P1	P2
	DIMENSIONS A - P2	B1-1/2ZRL	Packing	CW	2" NPT	1.50" NPT	8.50	6.63	5.25	3.63	4.75	0.87	0.50	4.85	2.90	1.04
B1-1/2ZRLS		Mechanical	CW	2" NPT	1.50" NPT	8.50	6.63	5.25	3.63	4.75	0.87	0.50	4.85	4.00	1.04	0.84
B1-1/2ERL		Packing	CW	2" NPT	1.50" NPT	8.50	6.12	5.25	3.63	4.75	0.87	0.50	5.14	4.69	0.42	0.95
B1-1/2ERLS		Mechanical	CW	2" NPT	1.50" NPT	8.50	6.12	5.25	3.63	4.75	0.87	0.50	5.14	4.69	0.42	0.95
B2ZRL		Packing	CW	2.50" NPT	2" NPT	8.50	6.63	5.25	3.63	4.75	0.87	0.50	4.85	2.90	1.04	0.84
B2ZRLS		Mechanical	CW	2.50" NPT	2" NPT	8.50	6.63	5.25	3.63	4.75	0.87	0.50	4.85	4.00	1.04	0.84
B2ZRM		Packing	CW	2.50" NPT	2" NPT	8.50	6.63	5.25	3.63	4.75	0.87	0.50	4.85	2.90	1.04	0.84
B2ZRMS		Mechanical	CW	2.50" NPT	2" NPT	8.50	6.63	5.25	3.63	4.75	0.87	0.50	4.85	4.00	1.04	0.84
B2ERL		Packing	CW	3" NPT	2" NPT	8.50	6.12	5.25	3.63	4.75	0.87	0.50	6.39	4.69	0.42	0.95
			CCW	3" NPT	2" NPT	8.50	6.12	5.25	3.63	4.75	0.87	0.50	6.39	4.69	0.42	0.95
B2ERLS		Mechanical	CW	3" NPT	2" NPT	8.50	6.12	5.25	3.63	4.75	0.87	0.50	6.39	4.69	0.42	0.95
B2ERH		Packing	CW	3" NPT	2" NPT	8.50	6.12	5.25	3.63	4.75	0.87	0.50	6.39	4.69	0.42	0.95
B2ERHS		Mechanical	CW	3" NPT	2" NPT	8.50	6.12	5.25	3.63	4.75	0.87	0.50	6.39	4.69	0.42	0.95
B2ERHH		Packing	CW	3" NPT	2" NPT	8.50	6.12	5.25	3.63	4.75	0.87	0.50	6.39	4.69	0.42	0.95
	CCW		3" NPT	2" NPT	8.50	6.12	5.25	3.63	4.75	0.87	0.50	6.39	4.69	0.42	0.95	
B2ERHHS	Mechanical	CW	3" NPT	2" NPT	8.50	6.12	5.25	3.63	4.75	0.87	0.50	6.39	4.69	0.42	0.95	

	PUMP MODEL	SHAFT SEAL	ROT	SUCTION	DISCHARGE	Q	Q1	U	X	Y	Z	CP	DD1	DD2	DD3	KEY †
	DIMENSIONS Q - KEY	B1-1/2ZRL	Packing	CW	2" NPT	1.50" NPT	6.60	2.86	1.125	5.38	2.88	5.06	17.24	5.50	5.94	6.25
B1-1/2ZRLS		Mechanical	CW	2" NPT	1.50" NPT	7.70	2.86	1.125	5.38	2.88	5.06	18.34	5.50	5.94	6.25	.25 sq x 2.125
B1-1/2ERL		Packing	CW	2" NPT	1.50" NPT	8.94	3.30	1.125	6.50	2.63	5.69	19.25	6.15	6.63	6.94	.25 sq x 2.125
B1-1/2ERLS		Mechanical	CW	2" NPT	1.50" NPT	8.94	3.30	1.125	6.50	2.63	5.69	19.25	6.15	6.63	6.94	.25 sq x 2.125
B2ZRL		Packing	CW	2.50" NPT	2" NPT	6.60	2.86	1.125	5.75	3.19	5.38	17.24	6.00	6.33	6.88	.25 sq x 2.125
B2ZRLS		Mechanical	CW	2.50" NPT	2" NPT	7.70	2.86	1.125	5.75	3.19	5.38	18.34	6.00	6.33	6.88	.25 sq x 2.125
B2ZRM		Packing	CW	2.50" NPT	2" NPT	6.60	2.86	1.125	5.75	3.19	5.38	17.24	6.00	6.33	6.88	.25 sq x 2.125
B2ZRMS		Mechanical	CW	2.50" NPT	2" NPT	7.70	2.86	1.125	5.75	3.19	5.38	18.34	6.00	6.33	6.88	.25 sq x 2.125
B2ERL		Packing	CW	3" NPT	2" NPT	8.94	3.30	1.125	5.92	3.75	6.06	20.50	6.81	7.06	7.56	.25 sq x 2.125
			CCW	3" NPT	2" NPT	8.94	3.30	1.125	5.94	3.75	6.06	20.50	6.81	7.06	7.56	.25 sq x 2.125
B2ERLS		Mechanical	CW	3" NPT	2" NPT	8.94	3.30	1.125	5.92	3.75	6.06	20.50	6.81	7.06	7.56	.25 sq x 2.125
B2ERH		Packing	CW	3" NPT	2" NPT	8.94	3.30	1.125	5.92	3.75	6.06	20.50	6.81	7.06	7.56	.25 sq x 2.125
B2ERHS		Mechanical	CW	3" NPT	2" NPT	8.94	3.30	1.125	5.92	3.75	6.06	20.50	6.81	7.06	7.56	.25 sq x 2.125
B2ERHH		Packing	CW	3" NPT	2" NPT	8.94	3.30	1.125	5.92	3.75	6.06	20.50	6.81	7.06	7.56	.25 sq x 2.125
			CCW	3" NPT	2" NPT	8.94	3.30	1.125	5.94	3.75	6.06	20.50	6.81	7.06	7.56	.25 sq x 2.125
B2ERHHS		Mechanical	CW	3" NPT	2" NPT	8.94	3.30	1.125	5.92	3.75	6.06	20.50	6.81	7.06	7.56	.25 sq x 2.125

† All Key Dimensions: Squared width and height followed by the length.



Frame Mount Dimensions

NPT (Threaded)

	PUMP MODEL	SHAFT SEAL	ROT	SUCTION	DISCHARGE	DIMENSIONS A - P2										
						A	B	D	E	F	G	H	L	N	P1	P2
	B2ERBH	Packing	CW	3" NPT	2" NPT	8.75	11.50	7.19	3.50	9.88	1.88	0.75	8.57	6.35	0.83	0.80
	B2ERBHS	Mechanical	CW	3" NPT	2" NPT	8.75	11.50	7.19	3.50	9.88	1.88	0.75	8.57	6.35	0.75	0.88
	B2-1/2ZRL	Packing	CW	3" NPT	2.50" NPT	8.50	6.63	5.25	3.63	4.75	0.87	0.50	5.54	4.19	1.04	0.84
	B2-1/2ZRLS	Mechanical	CW	3" NPT	2.50" NPT	8.50	6.63	5.25	3.63	4.75	0.87	0.50	5.54	4.19	1.04	0.84
	B2-1/2ZRM	Packing	CW	3" NPT	2.50" NPT	8.50	6.63	5.25	3.63	4.75	0.87	0.50	5.54	4.19	1.04	0.84
	B2-1/2ZRMS	Mechanical	CW	3" NPT	2.50" NPT	8.50	6.63	5.25	3.63	4.75	0.87	0.50	5.54	4.00	1.04	0.84
	B2-1/2JRMBM	Packing	CW	4" NPT	2.50" NPT	8.88	11.50	7.13	3.50	9.88	1.94	0.75	8.82	6.06	0.68	0.94
	B2-1/2JRMBMS	Mechanical	CW	4" NPT	2.50" NPT	8.75	11.50	7.00	3.50	9.88	1.87	0.75	8.75	6.06	0.75	0.88
	B3ZRM*	Packing	CW	4" NPT	3" NPT	11.50	10.50	6.00	5.00	9.00	0.75	0.63	6.01	4.63	0.75	0.75
			CCW	4" NPT	3" NPT	11.50	10.50	6.00	5.00	9.00	0.75	0.63	6.01	4.63	0.75	0.75
	B3ZRM**	Packing	CW	4" NPT**	3" NPT**	8.50	6.63	5.25	3.63	4.75	0.87	0.50	5.73	4.09	1.04	0.84
			CCW	4" NPT**	3" NPT**	8.50	6.63	5.25	3.63	4.75	0.87	0.50	5.73	5.37	1.04	0.84
	B3ZRMS*	Mechanical	CW	4" NPT	3" NPT	11.50	10.50	6.00	5.00	9.00	0.75	0.63	6.01	4.63	0.75	0.75
			CCW	4" NPT	3" NPT	11.50	10.50	6.00	5.00	9.00	0.75	0.63	6.01	4.63	0.75	0.75
	B3ZRMS	Mechanical	CW	4" NPT	3" NPT	8.50	6.63	5.25	3.63	4.75	0.87	0.50	5.73	4.09	1.04	0.84
			CCW	4" NPT	3" NPT	8.50	6.63	5.25	3.63	4.75	0.87	0.50	5.73	5.37	1.04	0.84
	B3ERBL	Packing	CW	4" NPT	3" NPT	8.75	11.50	7.19	3.50	9.88	1.88	0.75	9.38	6.35	0.83	0.80
			CCW	4" NPT	3" NPT	8.75	11.50	7.19	3.50	9.88	1.88	0.75	9.38	6.35	0.83	0.80
	B3ERBLS	Mechanical	CW	4" NPT	3" NPT	8.75	11.50	7.19	3.50	9.88	1.88	0.75	9.38	6.35	0.75	0.88
			CCW	4" NPT	3" NPT	8.75	11.50	7.19	3.50	9.88	1.88	0.75	9.38	6.35	0.75	0.88
	B3ERM	Packing	CW	4" NPT	3" NPT	8.50	6.12	5.25	3.63	4.75	0.87	0.50	7.20	4.69	0.42	0.95
	B3ERMS	Mechanical	CW	4" NPT	3" NPT	8.50	6.12	5.25	3.63	4.75	0.88	0.50	7.20	4.69	0.42	0.95
	B3JRMBM	Packing	CW	4" NPT	3" NPT	8.88	11.50	7.13	3.50	9.88	1.94	0.75	8.82	6.06	0.68	0.94
			CCW	4" NPT	3" NPT	8.88	11.50	7.13	3.50	9.88	1.94	0.75	8.82	6.06	0.68	0.94
	B3JRMBMS	Mechanical	CW	4" NPT	3" NPT	8.75	11.50	7.00	3.50	9.88	1.87	0.75	8.75	6.06	0.75	0.88
			CCW	4" NPT	3" NPT	8.75	11.50	7.00	3.50	9.88	1.87	0.75	8.75	6.06	0.75	0.88

	PUMP MODEL	SHAFT SEAL	ROT	SUCTION	DISCHARGE	DIMENSIONS Q - KEY										
						Q	Q1	U	X	Y	Z	CP	DD1	DD2	DD3	KEY †
	B2ERBH	Packing	CW	3" NPT	2" NPT	8.90	1.75	1.875	5.92	3.75	6.06	28.17	6.81	7.06	7.56	.50 sq x 4.000
	B2ERBHS	Mechanical	CW	3" NPT	2" NPT	8.98	1.75	1.875	5.92	3.75	6.06	28.17	6.81	7.06	7.56	.50 sq x 4.000
	B2-1/2ZRL	Packing	CW	3" NPT	2.50" NPT	7.89	2.86	1.125	6.25	3.69	5.50	19.22	6.38	6.75	7.25	.25 sq x 2.125
	B2-1/2ZRLS	Mechanical	CW	3" NPT	2.50" NPT	7.89	2.86	1.125	6.25	3.69	5.50	19.22	6.38	6.75	7.25	.25 sq x 2.125
	B2-1/2ZRM	Packing	CW	3" NPT	2.50" NPT	7.89	2.86	1.125	6.25	3.69	5.50	19.22	6.38	6.75	7.25	.25 sq x 2.125
	B2-1/2ZRMS	Mechanical	CW	3" NPT	2.50" NPT	7.70	2.86	1.125	6.25	3.69	5.50	19.03	6.38	6.75	7.25	.25 sq x 2.125
	B2-1/2JRMBM	Packing	CW	4" NPT	2.50" NPT	8.18	1.18	1.875	6.50	4.37	7.81	27.56	8.57	8.90	9.66	.50 sq x 4.000
	B2-1/2JRMBMS	Mechanical	CW	4" NPT	2.50" NPT	8.19	1.25	1.875	6.50	4.37	7.81	27.56	8.57	8.90	9.66	.50 sq x 4.000
	B3ZRM*	Packing	CW	4" NPT	3" NPT	6.88	1.50	1.487	7.00	3.63	5.88	22.64	6.78	6.92	8.04	.38 sq x 2.500
			CCW	4" NPT	3" NPT	6.88	1.50	1.487	7.25	3.63	5.88	22.64	6.78	6.92	8.04	.38 sq x 2.500
	B3ZRM**	Packing	CW	4" NPT**	3" NPT**	7.79	2.86	1.181	7.00	3.63	5.88	19.31	6.78	6.92	8.04	.25 sq x 2.125
			CCW	4" NPT**	3" NPT**	9.07	2.86	1.181	7.25	3.63	5.88	20.59	6.78	6.92	8.04	.25 sq x 2.125
	B3ZRMS*	Mechanical	CW	4" NPT	3" NPT	6.88	1.50	1.487	7.00	3.63	5.88	22.64	6.78	6.92	8.04	.38 sq x 2.500
			CCW	4" NPT	3" NPT	6.88	1.50	1.487	7.25	3.63	5.88	22.64	6.78	6.92	8.04	.38 sq x 2.500
	B3ZRMS	Mechanical	CW	4" NPT	3" NPT	7.79	2.86	1.181	7.00	3.63	5.88	19.31	6.78	6.92	8.04	.25 sq x 2.125
			CCW	4" NPT	3" NPT	9.07	2.86	1.181	7.25	3.63	5.88	20.59	6.78	6.92	8.04	.25 sq x 2.125
	B3ERBL	Packing	CW	4" NPT	3" NPT	8.90	1.75	1.875	8.62	4.31	6.50	28.98	7.47	7.56	8.66	.50 sq x 4.000
			CCW	4" NPT	3" NPT	8.90	1.75	1.875	8.63	4.31	6.50	28.98	7.47	7.56	8.66	.50 sq x 4.000
	B3ERBLS	Mechanical	CW	4" NPT	3" NPT	8.98	1.75	1.875	8.62	4.31	66.50	28.98	7.47	7.56	8.66	.50 sq x 4.000
			CCW	4" NPT	3" NPT	8.98	1.75	1.875	8.63	4.31	6.50	28.98	7.47	7.56	8.66	.50 sq x 4.000
	B3ERM	Packing	CW	4" NPT	3" NPT	8.94	3.30	1.125	8.62	4.31	6.50	21.31	7.47	7.56	8.66	.25 sq x 2.125
	B3ERMS	Mechanical	CW	4" NPT	3" NPT	8.94	3.30	1.125	8.62	4.31	6.50	21.31	7.47	7.56	8.66	.25 sq x 2.125
	B3JRMBM	Packing	CW	4" NPT	3" NPT	8.18	1.18	1.875	7.50	4.38	8.00	27.56	8.99	9.38	10.19	.50 sq x 4.000
			CCW	4" NPT	3" NPT	8.18	1.18	1.875	7.50	4.37	8.00	27.56	8.95	9.38	10.16	.50 sq x 4.000
	B3JRMBMS	Mechanical	CW	4" NPT	3" NPT	8.19	1.25	1.875	7.50	4.38	8.00	27.56	8.99	9.38	10.19	.50 sq x 4.000
			CCW	4" NPT	3" NPT	8.19	1.25	1.875	7.50	4.38	8.00	27.56	8.99	9.38	10.19	.50 sq x 4.000

*Heavy duty frame.

**NPT fitting with hydraulic adapter.

† All Key Dimensions: Squared width and height followed by the length.



Frame Mount Dimensions

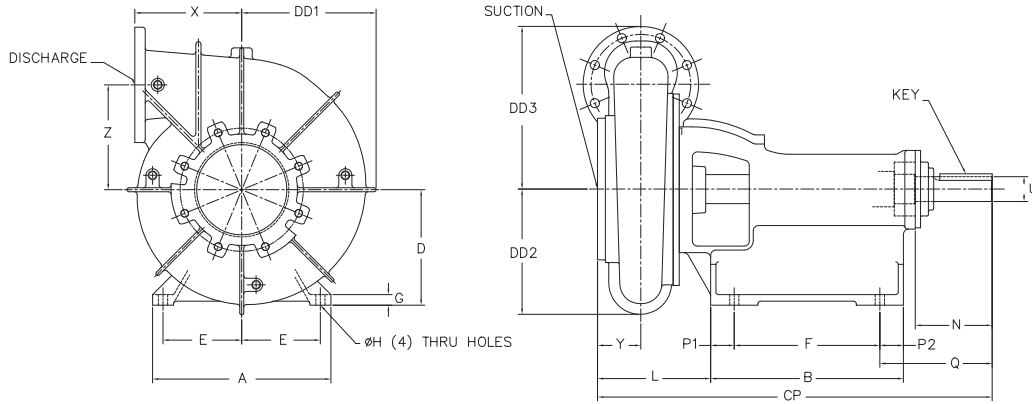

FLANGED (125# ANSI)

	PUMP MODEL	SHAFT SEAL	ROT	SUCTION ²	DISCHARGE ²	A	B	D	E	F	G	H	L	N	P1	P2
DIMENSIONS A - P2	B3ZRM ¹	Packing	CW	4.00"	3.00"	11.50	10.50	6.00	5.00	9.00	0.75	0.63	5.03	4.63	0.75	0.75
	B3ZRMS ¹	Mechanical	CW	4.00"	3.00"	11.50	10.50	6.00	5.00	9.00	0.75	0.63	5.03	4.63	0.75	0.75
	B3ZRMS	Mechanical	CW	4.00"	3.00"	8.50	6.63	5.25	3.63	4.75	0.87	0.50	4.75	4.09	1.04	0.84
	B4ERBM	Packing	CW	5.00"	4.00"	8.75	11.50	7.19	3.50	9.88	1.88	0.75	7.82	6.35	0.83	0.80
			CCW	5.00"	4.00"	8.75	11.50	7.19	3.50	9.88	1.88	0.75	7.82	6.35	0.83	0.80
	B4ERBMS	Mechanical	CW	5.00"	4.00"	8.75	11.50	7.19	3.50	9.88	1.88	0.75	7.82	6.35	0.75	0.88
			CCW	5.00"	4.00"	8.75	11.50	7.19	3.50	9.88	1.88	0.75	7.82	6.35	0.75	0.88
	B4ERM	Packing	CW	5.00"	4.00"	8.50	6.12	5.25	3.63	4.75	0.87	0.50	5.64	4.69	0.42	0.95
			CCW	5.00"	4.00"	8.50	6.12	5.25	3.63	4.75	0.87	0.50	5.64	4.69	0.42	0.95
	B4JRMBH	Packing	CW	5.00"	4.00"	8.88	11.50	7.13	3.50	9.88	1.94	0.75	7.07	6.06	0.68	0.94
			CCW	5.00"	4.00"	8.88	11.50	7.13	3.50	9.88	1.94	0.75	7.07	6.06	0.68	0.94
	B4JRMBHS	Mechanical	CW	5.00"	4.00"	8.75	11.50	7.00	3.50	9.88	1.87	0.75	7.00	6.06	0.75	0.88
			CCW	5.00"	4.00"	8.75	11.50	7.00	3.50	9.88	1.87	0.75	7.00	6.06	0.75	0.88
	B4JRMBHH ³	Packing	CW	5.00"	4.00"	8.88	11.50	7.13	3.50	9.88	1.94	0.75	7.07	6.06	0.68	0.94
	B4JRMBHHS ³	Mechanical	CW	5.00"	4.00"	8.75	11.50	7.00	3.50	9.88	1.87	0.75	7.00	6.06	0.75	0.88
	B4EYRMBM	Packing	CW	5.00"	4.00"	8.88	11.50	7.13	3.50	9.88	1.94	0.75	9.70	6.06	0.68	0.94
B4EYRMBMS	Mechanical	CW	5.00"	4.00"	8.75	11.50	7.00	3.50	9.88	1.87	0.75	9.63	6.06	0.75	0.88	
B4EYRMBH	Packing	CW	5.00"	4.00"	8.88	11.50	7.13	3.50	9.88	1.94	0.75	9.70	6.06	0.68	0.94	
B4EYRMBHS	Mechanical	CW	5.00"	4.00"	8.75	11.50	7.00	3.50	9.88	1.87	0.75	9.63	6.06	0.75	0.88	

	PUMP MODEL	SHAFT SEAL	ROT	SUCTION ²	DISCHARGE ²	Q	Q1	U	X	Y	Z	CP	DD1	DD2	DD3	KEY ⁶
DIMENSIONS Q - KEY	B3ZRM ¹	Packing	CW	4.00"	3.00"	6.88	1.50	1.487	6.88	2.68	5.88	21.66	6.78	6.92	9.63	.38 sq x 2.500
	B3ZRMS ¹	Mechanical	CW	4.00"	3.00"	6.88	1.50	1.487	6.88	2.68	5.88	21.66	6.78	6.92	9.63	.38 sq x 2.500
	B3ZRMS	Mechanical	CW	4.00"	3.00"	7.79	2.86	1.181	6.88	2.68	5.88	18.33	6.78	6.92	9.63	.25 sq x 2.125
	B4ERBM	Packing	CW	5.00"	4.00"	8.90	1.75	1.875	8.00	2.50	6.69	27.42	7.81	7.24	11.19	.50 sq x 4.000
			CCW	5.00"	4.00"	8.90	1.75	1.875	8.00	2.50	6.69	27.42	7.78	7.23	11.31	.50 sq x 4.000
	B4ERBMS	Mechanical	CW	5.00"	4.00"	8.98	1.75	1.875	8.00	2.50	6.69	27.42	7.81	7.24	11.19	.50 sq x 4.000
			CCW	5.00"	4.00"	8.98	1.75	1.875	8.00	2.50	6.69	27.42	7.78	7.23	11.31	.50 sq x 4.000
	B4ERM	Packing	CW	5.00"	4.00"	8.94	3.30	1.125	8.00	2.50	6.69	19.75	7.81	7.24	11.19	.25 sq x 2.125
			CCW	5.00"	4.00"	8.18	1.18	1.875	9.00	2.62	8.56	25.81	9.94	10.13	13.06	.50 sq x 4.000
	B4JRMBH	Packing	CW	5.00"	4.00"	8.18	1.18	1.875	9.00	2.62	8.56	25.81	9.94	10.13	13.07	.50 sq x 4.000
			CCW	5.00"	4.00"	8.18	1.18	1.875	9.00	2.62	8.56	25.81	9.94	10.13	13.07	.50 sq x 4.000
	B4JRMBHS	Mechanical	CW	5.00"	4.00"	8.19	1.25	1.875	9.00	2.62	8.56	25.81	9.94	10.13	13.06	.50 sq x 4.000
			CCW	5.00"	4.00"	8.19	1.25	1.875	9.00	2.62	8.56	25.81	9.94	10.13	13.07	.50 sq x 4.000
	B4JRMBHH ³	Packing	CW	5.00"	4.00"	8.18	1.18	1.875	9.00	2.62	8.56	25.81	9.94	10.29	13.09	.50 sq x 4.000
	B4JRMBHHS ³	Mechanical	CW	5.00"	4.00"	8.19	1.25	1.875	9.00	2.62	8.56	25.81	9.94	10.29	13.09	.50 sq x 4.000
	B4EYRMBM	Packing	CW	5.00"	4.00"	8.18	1.18	1.875	12.00	5.25	10.50	28.44	12.34	11.83	15.00	.50 sq x 4.000
B4EYRMBMS	Mechanical	CW	5.00"	4.00"	8.19	1.25	1.875	12.00	5.25	10.50	28.44	12.34	11.83	15.00	.50 sq x 4.000	
B4EYRMBH	Packing	CW	5.00"	4.00"	8.18	1.18	1.875	12.00	5.25	10.50	28.44	12.34	11.83	15.00	.50 sq x 4.000	
B4EYRMBHS	Mechanical	CW	5.00"	4.00"	8.19	1.25	1.875	12.00	5.25	10.50	28.44	12.34	11.83	15.00	.50 sq x 4.000	

¹Heavy duty frame.

³Requires a 6" x 10" special suction flange available through Berkeley.

⁵Measurement without separate flange attachment.

²125# ANSI.

⁴Flange kit needed for both packing and mechanical versions.

⁶All Key Dimensions: Squared width and height followed by the length.



Frame Mount Dimensions

FLANGED (125# ANSI)

DIMENSIONS A - P2	PUMP MODEL	SHAFT SEAL	ROT	SUCTION ²	DISCHARGE ²	A	B	D	E	F	G	H	L	N	P1	P2
	B6ZRL ¹	Packing	CW	8.00"	6.00"	11.50	10.50	6.00	5.00	9.00	0.75	0.63	7.75	4.63	0.75	0.75
	B6ZRL	Packing	CW	8.00"	6.00"	8.50	6.63	5.25	3.63	4.75	0.87	0.50	7.47	4.19	1.04	0.84
	B6ZRLS ¹	Mechanical	CW	8.00"	6.00"	11.50	10.50	6.00	5.00	9.00	0.75	0.63	7.75	4.63	0.75	0.75
	B6ZRLS	Mechanical	CW	8.00"	6.00"	8.50	6.63	5.25	3.63	4.75	0.87	0.50	7.47	4.18	1.04	0.84
	B6ZRM ⁴	Packing	CCW	8.00"	6.00"	8.50	6.63	5.25	3.63	4.75	0.87	0.50	6.98	5.37	1.04	0.84
	B6ZRMS ⁴	Mechanical	CCW	8.00"	6.00"	8.50	6.63	5.25	3.63	4.75	0.87	0.50	6.98	5.37	1.04	0.84
	B6ZRH ¹	Packing	CW	8.00"	6.00"	11.50	10.50	6.00	5.00	9.00	0.75	0.63	7.75	4.63	0.75	0.75
	B6ZRH	Packing	CW	8.00"	6.00"	8.50	6.63	5.25	3.63	4.75	0.87	0.50	7.47	4.19	1.04	0.84
	B6ZRHS ¹	Mechanical	CW	8.00"	6.00"	11.50	10.50	6.00	5.00	9.00	0.75	0.63	7.75	4.63	0.75	0.75
	B6ZRHS	Mechanical	CW	8.00"	6.00"	8.50	6.63	5.25	3.63	4.75	0.87	0.50	7.47	4.18	1.04	0.84
	B6JRMBL	Packing	CW	8.00"	6.00"	8.88	11.50	7.13	3.50	9.88	1.94	0.75	7.95	6.06	0.68	0.94
			CCW	8.00"	6.00"	8.88	11.50	7.13	3.50	9.88	1.94	0.75	7.95	6.06	0.68	0.94
	B6JRMBLS	Mechanical	CW	8.00"	6.00"	8.75	11.50	7.00	3.50	9.88	1.87	0.75	7.88	6.06	0.75	0.88
			CCW	8.00"	6.00"	8.75	11.50	7.00	3.50	9.88	1.87	0.75	7.88	6.06	0.75	0.88
	B6JRMBM	Packing	CW	8.00"	6.00"	8.88	11.50	7.13	3.50	9.88	1.94	0.75	8.92	6.06	0.68	0.94
			CCW	8.00"	6.00"	8.88	11.50	7.13	3.50	9.88	1.94	0.75	7.95	6.06	0.68	0.94
B6JRMBMS	Mechanical	CW	8.00"	6.00"	8.75	11.50	7.00	3.50	9.88	1.87	0.75	8.85	6.06	0.75	0.88	
		CCW	8.00"	6.00"	8.75	11.50	7.00	3.50	9.88	1.87	0.75	7.88	6.06	0.75	0.88	
B6JBMBH	Packing	CW	8.00"	6.00"	8.88	11.50	7.13	3.50	9.88	1.94	0.75	8.82	6.06	0.68	0.94	
B6JBMBHS	Mechanical	CW	8.00"	6.00"	8.75	11.50	7.00	3.50	9.88	1.87	0.75	8.75	6.06	0.75	0.88	
B6EXRBL	Packing	CW	8.00"	6.00"	18.82	16.81	11.00	7.50	13.88	1.07	0.88	9.97	7.33	2.44	2.48	
B6EXRBH	Packing	CW	8.00"	6.00"	8.75	11.50	7.00	3.50	9.88	1.87	0.75	8.75	6.06	0.75	0.88	
B8GRMBM	Packing	CW	10.00"	8.00"	8.88	11.50	7.13	3.50	9.88	1.94	0.75	9.45	6.06	0.68	0.94	
		CCW	10.00"	8.00"	8.88	11.50	7.13	3.50	9.88	1.94	0.75	9.45	26.06	0.68	0.94	
B8GRMBMS	Mechanical	CW	10.00"	8.00"	8.75	11.50	7.00	3.50	9.88	1.87	0.75	9.38	6.06	0.75	0.88	
		CCW	10.00"	8.00"	8.75	11.50	7.00	3.50	9.88	1.87	0.75	9.38	6.06	0.75	0.88	
B10GRMBM	Packing	CW	12.00"	10.00"	8.88	11.50	7.13	3.50	9.88	1.94	0.75	10.57	6.06	0.68	0.84	
B10GRMBMS	Mechanical	CW	12.00"	10.00"	8.75	11.50	7.00	3.50	9.88	1.87	0.75	10.50	6.06	0.75	0.88	

DIMENSIONS Q - KEY	PUMP MODEL	SHAFT SEAL	ROT	SUCTION ²	DISCHARGE ²	Q	Q1	U	X	Y	Z	CP	DD1	DD2	DD3	KEY ⁶
	B6ZRL ¹	Packing	CW	8.00"	6.00"	6.88	1.50	1.487	8.00	4.00	7.31	24.38	8.91	7.66	12.81	.38 sq x 2.500
	B6ZRL	Packing	CW	8.00"	6.00"	7.89	2.86	1.125	8.00	4.00	7.31	21.15	8.91	7.66	12.81	.25 sq x 2.125
	B6ZRLS ¹	Mechanical	CW	8.00"	6.00"	6.88	1.50	1.487	8.00	4.00	7.31	24.38	8.91	7.66	12.81	.38 sq x 2.500
	B6ZRLS	Mechanical	CW	8.00"	6.00"	7.88	2.86	1.125	8.00	4.00	7.31	21.14	8.91	7.66	12.81	.25 sq x 2.125
	B6ZRM ⁴	Packing	CCW	8.00"	6.00"	9.07	2.86	1.181	6.02 ⁵	3.51 ⁵	7.31	21.84	8.98	7.62	11.09 ⁵	.25 sq x 2.125
	B6ZRMS ⁴	Mechanical	CCW	8.00"	6.00"	9.07	2.86	1.181	6.02 ⁵	3.51 ⁵	7.31	21.84	8.98	7.62	11.09 ⁵	.25 sq x 2.125
	B6ZRH ¹	Packing	CW	8.00"	6.00"	6.88	1.50	1.487	8.00	4.00	7.31	24.38	8.91	7.66	12.81	.38 sq x 2.500
	B6ZRH	Packing	CW	8.00"	6.00"	7.89	2.86	1.125	8.00	4.00	7.31	21.15	8.91	7.66	12.81	.25 sq x 2.125
	B6ZRHS ¹	Mechanical	CW	8.00"	6.00"	6.88	1.50	1.487	8.00	4.00	7.31	24.38	8.91	7.66	12.81	.38 sq x 2.500
	B6ZRHS	Mechanical	CW	8.00"	6.00"	7.88	2.86	1.125	8.00	4.00	7.31	21.14	8.91	7.66	12.81	.25 sq x 2.125
	B6JRMBL	Packing	CW	8.00"	6.00"	8.18	1.18	1.875	11.00	3.00	8.75	26.69	9.95	9.89	14.25	.50 sq x 4.000
			CCW	8.00"	6.00"	8.18	1.18	1.875	11.00	3.00	8.75	26.69	9.95	9.89	14.25	.50 sq x 4.000
	B6JRMBLS	Mechanical	CW	8.00"	6.00"	8.19	1.25	1.875	11.00	3.00	8.75	26.69	9.95	9.89	14.25	.50 sq x 4.000
			CCW	8.00"	6.00"	8.19	1.25	1.875	11.00	3.00	8.75	26.69	9.95	9.89	14.25	.50 sq x 4.000
	B6JRMBM	Packing	CW	8.00"	6.00"	8.18	1.18	1.875	12.00	3.97	10.50	27.66	12.76	10.69	15.94	.50 sq x 4.000
			CCW	8.00"	6.00"	8.18	1.18	1.875	11.00	3.00	8.75	26.69	9.95	9.89	14.25	.50 sq x 4.000
B6JRMBMS	Mechanical	CW	8.00"	6.00"	8.19	1.25	1.875	12.00	3.97	10.50	27.66	12.76	10.69	15.94	.50 sq x 4.000	
		CCW	8.00"	6.00"	8.19	1.25	1.875	11.00	3.00	8.75	26.69	9.95	9.89	14.25	.50 sq x 4.000	
B6JBMBH	Packing	CW	8.00"	6.00"	8.18	1.18	1.875	11.00	3.88	8.75	27.56	9.96	9.89	14.25	.50 sq x 4.000	
B6JBMBHS	Mechanical	CW	8.00"	6.00"	8.19	1.25	1.875	11.00	3.88	8.75	27.56	9.96	9.89	14.25	.50 sq x 4.000	
B6EXRBL	Packing	CW	8.00"	6.00"	10.71	0.90	2.375	10.19	4.12	10.00	35.01	12.81	11.93	15.50	.63 sq x 5.000	
B6EXRBH	Packing	CW	8.00"	6.00"	8.19	1.25	1.875	11.00	3.88	8.75	27.56	9.96	9.89	14.25	.50 sq x 4.000	
B8GRMBM	Packing	CW	10.00"	8.00"	8.18	1.18	1.875	12.75	4.00	9.88	28.19	12.44	12.01	16.63	.50 sq x 4.000	
		CCW	10.00"	8.00"	8.18	1.18	1.875	12.75	4.00	9.88	28.19	12.44	12.01	16.63	.50 sq x 4.000	
B8GRMBMS	Mechanical	CW	10.00"	8.00"	8.19	1.25	1.875	12.75	4.00	9.88	28.19	12.44	12.01	16.63	.50 sq x 4.000	
		CCW	10.00"	8.00"	8.19	1.25	1.875	12.75	4.00	9.88	28.19	12.44	12.01	16.63	.50 sq x 4.000	
B10GRMBM	Packing	CW	12.00"	10.00"	8.18	1.18	1.875	12.88	4.37	9.59	29.31	11.71	10.04	17.59	.50 sq x 4.000	
B10GRMBMS	Mechanical	CW	12.00"	10.00"	8.19	1.25	1.875	12.88	4.37	9.59	29.31	11.71	10.04	17.59	.50 sq x 4.000	

¹Heavy duty frame.

³Requires a 6" x 10" special suction flange available through Berkeley.

⁵Measurement without separate flange attachment.

²125# ANSI.

⁴Flange kit needed for both packing and mechanical versions.

⁶All Key Dimensions: Squared width and height followed by the length.

Frame Mount Dimensions

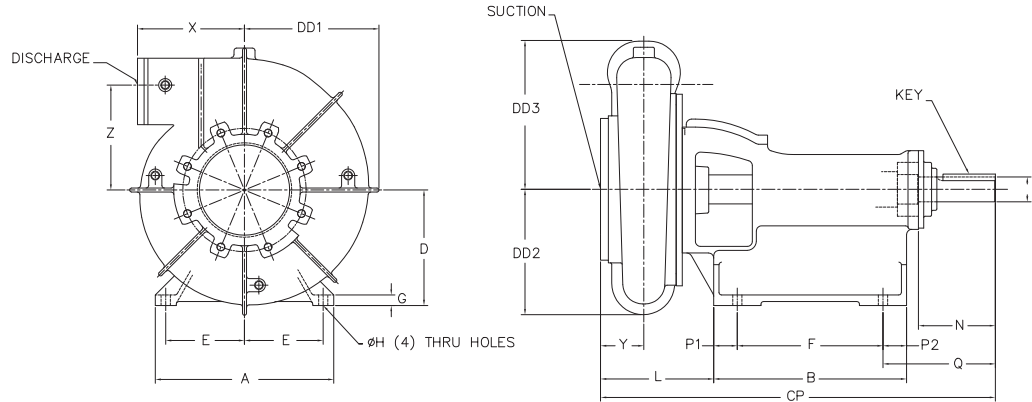

VICTAULIC

PUMP MODEL		SHAFT SEAL	ROT	SUCTION ²	DISCHARGE ²	A	B	D	E	F	G	H	L	N	P1	P2
DIMENSIONS A - P2	B3ZRM ¹	Packing	CW	4.00" VIC	3.00" VIC	11.50	10.50	6.00	5.00	9.00	0.75	0.63	5.88	4.63	0.75	0.75
			CCW	4.00" VIC	3.00" VIC	11.50	10.50	6.00	5.00	9.00	0.75	0.63	5.88	4.63	0.75	0.75
	B3ZRM	Packing	CW	4.00" VIC	3.00" VIC	8.50	6.63	5.25	3.63	4.75	0.87	0.50	5.60	4.09	1.04	0.84
			CCW	4.00" VIC	3.00" VIC	8.50	6.63	5.25	3.63	4.75	0.87	0.50	5.60	5.37	1.04	0.84
	B3ZRMS ¹	Mechanical	CW	4.00" VIC	3.00" VIC	11.50	10.50	6.00	5.00	9.00	0.75	0.63	5.88	4.63	0.75	0.75
			CCW	4.00" VIC	3.00" VIC	11.50	10.50	6.00	5.00	9.00	0.75	0.63	5.88	4.63	0.75	0.75
B3ZRMS	Mechanical	CW	4.00" VIC	3.00" VIC	8.50	6.63	5.25	3.63	4.75	0.87	0.50	5.60	4.09	1.04	0.84	
		CCW	4.00" VIC	3.00" VIC	8.50	6.63	5.25	3.63	4.75	0.87	0.50	5.60	5.37	1.04	0.84	
PUMP MODEL		SHAFT SEAL	ROT	SUCTION ²	DISCHARGE ²	Q	Q1	U	X	Y	Z	CP	DD1	DD2	DD3	KEY ⁶
DIMENSIONS Q - KEY	B3ZRM	Packing	CW	4.00" VIC	3.00" VIC	6.88	1.50	1.487	6.88	3.50	5.88	22.51	6.77	6.93	7.63	.38 sq x 2.500
			CCW	4.00" VIC	3.00" VIC	6.88	1.50	1.487	6.88	3.50	5.88	22.51	6.77	6.93	7.60	.38 sq x 2.500
	B3ZRM	Packing	CW	4.00" VIC	3.00" VIC	7.79	2.86	1.181	6.88	3.50	5.88	19.18	6.77	6.93	7.63	.25 sq x 2.125
			CCW	4.00" VIC	3.00" VIC	9.07	2.86	1.181	6.88	3.50	5.88	20.46	6.77	6.93	7.60	.25 sq x 2.125
	B3ZRMS	Mechanical	CW	4.00" VIC	3.00" VIC	6.88	1.50	1.487	6.88	3.50	5.88	22.51	6.77	6.93	7.63	.38 sq x 2.500
			CCW	4.00" VIC	3.00" VIC	6.88	1.50	1.487	6.88	3.50	5.88	22.51	6.77	6.93	7.60	.38 sq x 2.500
	B3ZRMS	Mechanical	CW	4.00" VIC	3.00" VIC	7.79	2.86	1.181	6.88	3.50	5.88	19.18	6.77	6.93	7.63	.25 sq x 2.125
			CCW	4.00" VIC	3.00" VIC	9.07	2.86	1.181	6.88	3.50	5.88	20.46	6.77	6.93	7.60	.25 sq x 2.125

¹Heavy duty frame.
²125# ANSI.

³Requires a 6" x 10" special suction flange available through Berkeley.
⁴Flange kit needed for both packing and mechanical versions.

⁵Measurement without separate flange attachment.
⁶All Key Dimensions: Squared width and height followed by the length.



Hydraulic Drive Dimensions

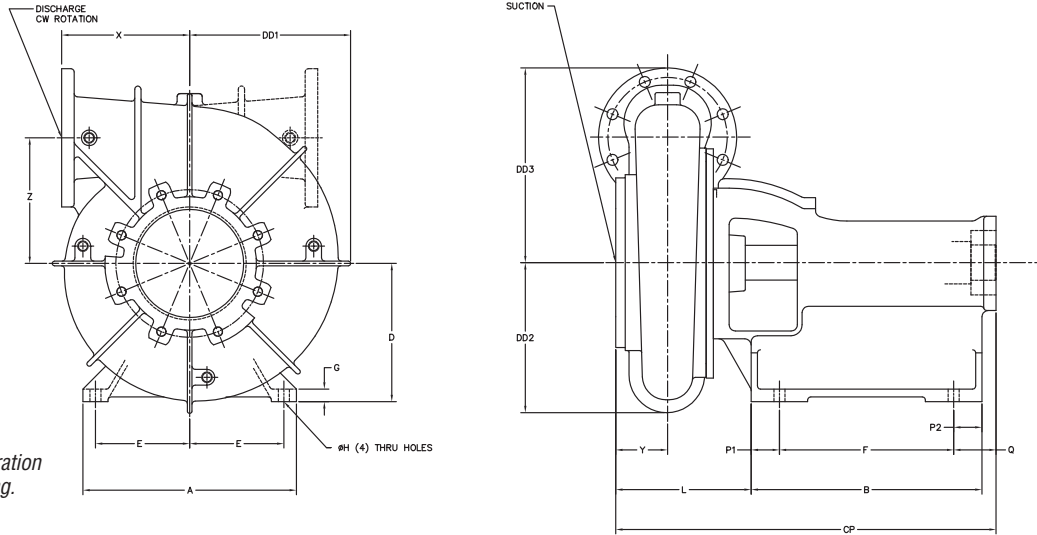

NPT (Threaded)

DIMENSIONS A - P2	PUMP MODEL	SHAFT SEAL	ROT	SUCTION	DISCHARGE	A	B	D	E	F	G	H	L	P1	P2
	B2-1/2JRMBMS	MECHANICAL	CW	4" NPT	2.50" NPT	8.75	11.52	7.00	3.50	9.88	1.87	0.75	8.75	0.75	0.88
	B3JRMBMS	MECHANICAL	CW	4" NPT	3" NPT	8.75	11.52	7.00	3.50	9.88	1.87	0.75	8.75	0.75	0.88
	B3ZRM	PACKING	CW	4" NPT	3" NPT	8.50	6.00	5.38	3.63	4.75	0.75	0.50	6.32	0.44	0.81
			CCW	4" NPT	3" NPT	8.50	6.00	5.38	3.63	4.75	0.75	0.50	6.32	0.44	0.81
B3ZRMS	MECHANICAL	CW	4" NPT	3" NPT	8.50	6.63	5.25	3.63	4.75	0.88	0.50	5.76	1.00	0.88	

DIMENSIONS Q - DD3	PUMP MODEL	SHAFT SEAL	ROT	SUCTION	DISCHARGE	Q	X	Y	Z	CP	DD1	DD2	DD3
	B2-1/2JRMBMS	MECHANICAL	CW	4" NPT	2.50" NPT	7.20	6.50	4.37	7.81	26.59	8.57	8.90	9.66
	B3JRMBMS	MECHANICAL	CW	4" NPT	3" NPT	7.20	7.50	4.38	8.00	26.59	8.99	9.38	10.19
	B3ZRM	PACKING	CW	4" NPT	3" NPT	3.24	7.00	3.63	5.88	15.56	6.78	6.92	8.04
			CCW	4" NPT	3" NPT	3.24	7.25	3.63	5.88	15.56	6.78	6.92	8.04
B3ZRMS	MECHANICAL	CW	4" NPT	3" NPT	7.44	7.25	3.63	5.88	19.82	6.78	6.92	8.04	

FLANGED (125# ANSI)

DIMENS. A - P2	PUMP MODEL	SHAFT SEAL	ROT	SUCTION	DISCHARGE	A	B	D	E	F	G	H	L	P1	P2
	B3ZRM	PACKING	CW	4.00"	3.00"	8.50	6.00	5.38	3.63	4.75	0.75	0.50	5.34	0.44	0.81
	B4JRMBHS	MECHANICAL	CW	5.00"	4.00"	8.75	11.52	7.00	3.50	9.88	1.87	0.75	7.00	0.75	0.88

DIMENS. Q - DD3	PUMP MODEL	SHAFT SEAL	ROT	SUCTION	DISCHARGE	Q	X	Y	Z	CP	DD1	DD2	DD3
	B3ZRM	PACKING	CW	4.00"	3.00"	3.24	6.88	2.68	5.88	14.58	6.78	6.92	9.63
	B4JRMBHS	MECHANICAL	CW	5.00"	4.00"	7.20	9.00	2.62	8.56	24.84	9.94	10.13	13.06

VICTAULIC

DIMENS. A - P2	PUMP MODEL	SHAFT SEAL	ROT	SUCTION	DISCHARGE	A	B	D	E	F	G	H	L	P1	P2
	B3ZRM	PACKING	CW	4.00" VIC	3.00" VIC	8.50	6.00	5.38	3.63	4.75	0.75	0.50	6.19	0.94	0.44
			CCW	4.00" VIC	3.00" VIC	8.50	6.00	5.38	3.63	4.75	0.75	0.50	6.19	0.94	0.44

DIMENS. Q - DD3	PUMP MODEL	SHAFT SEAL	ROT	SUCTION	DISCHARGE	Q	X	Y	Z	CP	DD1	DD2	DD3
	B3ZRM	PACKING	CW	4.00" VIC	3.00" VIC	3.24	6.88	3.50	5.25	5.88	6.77	6.93	7.63
			CCW	4.00" VIC	3.00" VIC	3.24	6.88	3.50	5.25	5.88	6.77	6.93	7.60

SAE Mount Dimensions – Flywheel Housings

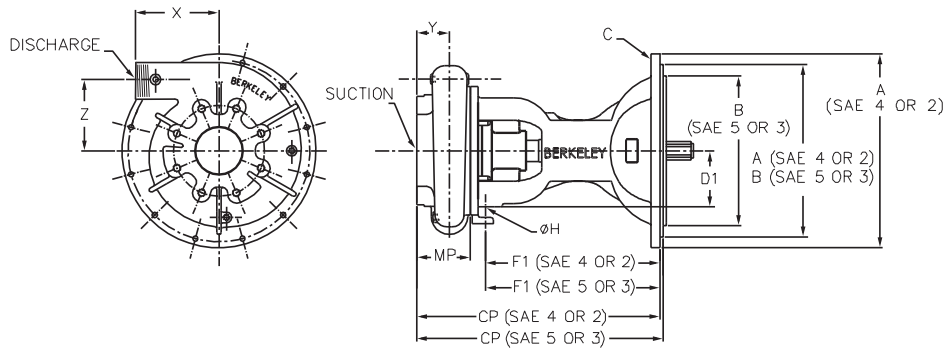

NPT (Threaded)

PUMP MODEL	SHAFT SEAL	SUCTION	DISCHARGE	SHAFT SPLINE SIZE	CLUTCH SIZE	SAE SHAFT EXT.	X	Y	MP	Z
B3ZQM	Packing	4"	3"	1-1/2" – 10T	6.5	(4) 2-3/4"	7.00	3.63	5.38	5.88
	Packing	4"	3"	1-1/2" – 10T	7.5	(4) 2-3/4"	7.00	3.63	5.38	5.88
	Packing	4"	3"	1-1/2" – 10T	8	(4) 2-3/4"	7.00	3.63	5.38	5.88
	Packing	4"	3"	1-1/2" – 10T	10	(4) 2-3/4"	7.00	3.63	5.38	5.88
B3ZQMS	Mechanical	4"	3"	1-1/2" – 10T	6.5	(4) 2-3/4"	7.00	3.63	5.38	5.88
	Mechanical	4"	3"	1-1/2" – 10T	7.5	(4) 2-3/4"	7.00	3.63	5.38	5.88
	Mechanical	4"	3"	1-1/2" – 10T	8	(4) 2-3/4"	7.00	3.63	5.38	5.88
	Mechanical	4"	3"	1-1/2" – 10T	10	(4) 2-3/4"	7.00	3.63	5.38	5.88

PUMP MODEL	SHAFT SEAL	SUCTION	DISCHARGE	SHAFT SPLINE SIZE	CLUTCH SIZE	SAE () SHAFT EXT.	C					DIA. H	F1	D1	CP
							A	B	BOLT CIRCLE	QTY. HOLES	HOLE SIZE				
B3ZQM	Packing	4"	3"	1-1/2" – 10T	6.5	(4) 2-3/4"	16.00	14.25	15.00	12	0.44	NA	NA	NA	21.01
						(5) 2-1/2"	14.25	12.37	13.12	8	0.44	NA	NA	NA	21.26
	Packing	4"	3"	1-1/2" – 10T	7.5	(4) 2-3/4"	16.00	14.25	15.00	12	0.44	NA	NA	NA	21.01
						(5) 2-1/2"	14.25	12.37	13.12	8	0.44	NA	NA	NA	21.26
	Packing	4"	3"	1-1/2" – 10T	8	(4) 2-3/4"	16.00	14.25	15.00	12	0.44	NA	NA	NA	21.01
						(5) 2-1/2"	14.25	12.37	13.12	8	0.44	NA	NA	NA	21.26
	Packing	4"	3"	1-1/2" – 10T	10	(4) 2-3/4"	16.00	14.25	15.00	12	0.44	NA	NA	NA	21.01
						(5) 2-1/2"	14.25	12.37	13.12	8	0.44	NA	NA	NA	21.26
B3ZQMS	Mechanical	4"	3"	1-1/2" – 10T	6.5	(4) 2-3/4"	16.00	14.25	15.00	12	0.44	NA	NA	NA	21.01
						(5) 2-1/2"	14.25	12.37	13.12	8	0.44	NA	NA	NA	21.26
	Mechanical	4"	3"	1-1/2" – 10T	7.5	(4) 2-3/4"	16.00	14.25	15.00	12	0.44	NA	NA	NA	21.01
						(5) 2-1/2"	14.25	12.37	13.12	8	0.44	NA	NA	NA	21.26
	Mechanical	4"	3"	1-1/2" – 10T	8	(4) 2-3/4"	16.00	14.25	15.00	12	0.44	NA	NA	NA	21.01
						(5) 2-1/2"	14.25	12.37	13.12	8	0.44	NA	NA	NA	21.26
	Mechanical	4"	3"	1-1/2" – 10T	10	(4) 2-3/4"	16.00	14.25	15.00	12	0.44	NA	NA	NA	21.01
						(5) 2-1/2"	14.25	12.37	13.12	8	0.44	NA	NA	NA	21.26

SAE Mount Dimensions – Flywheel Housings

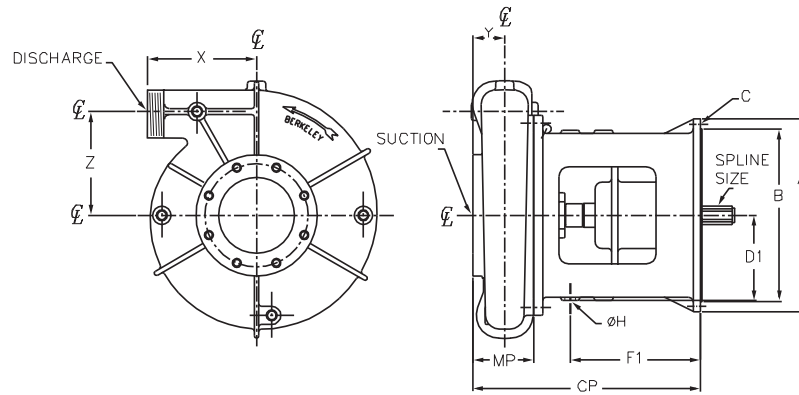

NPT (Threaded)

	PUMP MODEL	SHAFT SEAL	NPT (Threaded)		SHAFT SPLINE SIZE	SHAFT EXT.	SAE HOUSING SIZE	X	Y	MP	Z
			SUCTION	DISCHARGE							
VOLUTE DIMENSIONS	B1-1/2ZQM	Packing	2"	1-1/2"	1-3/8" – 10T	2-1/2"	5	5.38	2.88	4.50	5.06
	B1-1/2EQL	Packing	2"	1-1/2"	1-3/8" – 10T	2-1/2"	5	6.50	2.63	4.19	5.69
	B2ZQM	Packing	2-1/2"	2"	1-3/8" – 10T	2-1/2"	5	5.75	3.18	4.19	5.06
	B2EQHH	Packing	3"	2"	1-3/8" – 10T	2-1/2"	5	5.94	3.75	5.44	6.06
		Packing	3"	2"	1-3/8" – 10T	3"	4	5.94	3.75	5.44	6.06
	B2-1/2ZQM	Packing	3"	2-1/2"	1-3/8" – 10T	2-1/2"	5	6.25	3.68	5.18	5.50
		Packing	3"	2-1/2"	1-3/8" – 10T	3"	4	6.25	3.68	5.18	5.50
	B2-1/2JQBL	Packing	4"	2-1/2"	1-3/8" – 10T	3"	3	6.50	4.38	6.75	7.81
		Packing	4"	2-1/2"	1-3/8" – 10T	3"	4	6.50	4.38	6.75	7.81
	B2-1/2JQBL	Packing	4"	2-1/2"	1-3/8" – 10T	2-1/2"	5	6.50	4.38	6.75	7.81
		Mechanical	4"	2-1/2"	1-3/8" – 10T	3"	4	6.50	4.38	6.75	7.81
	B2-1/2JQBM	Packing	4"	2-1/2"	1-3/8" – 10T	3"	3	6.50	4.38	6.75	7.81
		Packing	4"	2-1/2"	1-3/8" – 10T	3"	4	6.50	4.38	6.75	7.81
		Packing	4"	2-1/2"	1-3/8" – 10T	2-1/2"	5	6.50	4.38	6.75	7.81
	B2-1/2JQBMS	Mechanical	4"	2-1/2"	1-3/8" – 10T	3"	3	6.50	4.38	6.75	7.81
		Mechanical	4"	2-1/2"	1-3/8" – 10T	3"	4	6.50	4.38	6.75	7.81
	B3EQBL	Packing	4"	3"	1-3/8" – 10T	2-1/2"	5	8.62	4.31	6.25	6.50
		Packing	4"	3"	1-3/8" – 10T	3"	4	8.62	4.31	6.25	6.50
		Packing	4"	3"	1-3/8" – 10T	3"	3	8.62	4.31	6.25	6.50
	B3JQBM	Packing	4"	3"	1-1/2" – 10T	2-1/2"	5	7.50	4.38	6.75	8.00
Packing		4"	3"	1-1/2" – 10T	3"	4	7.50	4.38	6.75	8.00	
Packing		4"	3"	1-1/2" – 10T	3"	3	7.50	4.38	6.75	8.00	
Packing		4"	3"	1-1/2" – 10T	3"	2	7.50	4.38	6.75	8.00	
Packing		4"	3"	1-1/2" – 10T	3"	1	7.50	4.38	6.75	8.00	
B3JQBMS	Mechanical	4"	3"	1-1/2" – 10T	3"	4	7.50	4.38	6.75	8.00	
	Mechanical	4"	3"	1-1/2" – 10T	3"	3	7.50	4.38	6.75	8.00	
	Dry Run	4"	3"	1-1/2" – 10T	3"	4	7.50	4.38	6.75	8.00	



SAE Mount Dimensions – Flywheel Housings

NPT (Threaded)

	PUMP MODEL	SHAFT SEAL	SUCTION	DISCHARGE	SHAFT SPLINE SIZE	SHAFT EXT.	SAE HOUSING SIZE	A	B	C			DIA. H	F1	D1	CP
										BOLT CIRCLE	QTY. HOLES	HOLE SIZE				
BRACKET DIMENSIONS	B1-1/2ZQM	Packing	2"	1-1/2"	1-3/8" – 10T	2-1/2"	5	14.00	12.37	13.12	7	0.44	0.44	9.00	4.62	15.00
	B1-1/2EQL	Packing	2"	1-1/2"	1-3/8" – 10T	2-1/2"	5	14.00	12.37	13.12	7	0.44	0.56	12.12	6.50	17.19
	B2ZQM	Packing	2-1/2"	2"	1-3/8" – 10T	2-1/2"	5	14.00	12.37	13.12	7	0.44	0.44	9.00	4.62	14.69
	B2EQHH	Packing	3"	2"	1-3/8" – 10T	2-1/2"	5	14.00	12.37	13.12	7	0.44	0.56	12.12	6.50	18.44
		Packing	3"	2"	1-3/8" – 10T	3"	4	15.88	14.25	15.00	12	0.44	0.56	12.13	6.50	18.44
	B2-1/2ZQM	Packing	3"	2-1/2"	1-3/8" – 10T	2-1/2"	5	14.00	12.37	13.12	7	0.44	0.44	9.00	4.62	15.68
		Packing	3"	2-1/2"	1-3/8" – 10T	3"	4	15.88	14.25	15.00	12	0.44	0.44	9.06	4.56	15.68
	B2-1/2JQBL	Packing	4"	2-1/2"	1-3/8" – 10T	3"	3	17.75	16.12	16.88	12	0.44	0.56	10.75	7.00	20.50
		Packing	4"	2-1/2"	1-3/8" – 10T	3"	4	15.88	14.25	15.00	12	0.44	0.56	10.75	7.00	20.50
		Packing	4"	2-1/2"	1-3/8" – 10T	2-1/2"	5	14.00	12.37	13.12	7	0.44	0.56	10.75	7.00	20.50
	B2-1/2JQBLS	Mechanical	4"	2-1/2"	1-3/8" – 10T	3"	4	15.88	14.25	15.00	12	0.44	0.56	10.75	7.00	20.50
	B2-1/2JQBM	Packing	4"	2-1/2"	1-3/8" – 10T	3"	3	17.75	16.12	16.88	12	0.44	0.56	10.75	7.00	20.50
		Packing	4"	2-1/2"	1-3/8" – 10T	3"	4	15.88	14.25	15.00	12	0.44	0.56	10.75	7.00	20.50
		Packing	4"	2-1/2"	1-3/8" – 10T	2-1/2"	5	14.00	12.37	13.12	7	0.44	0.56	10.75	7.00	20.50
		Packing	4"	2-1/2"	1-3/8" – 10T	3"	2	19.25	17.62	18.38	12	0.44	0.56	10.75	7.00	20.50
	B2-1/2JQBMS	Mechanical	4"	2-1/2"	1-3/8" – 10T	3"	3	17.75	16.12	16.88	12	0.44	0.56	10.75	7.00	20.50
		Mechanical	4"	2-1/2"	1-3/8" – 10T	3"	4	15.88	14.25	15.00	12	0.44	0.56	10.75	7.00	20.50
	B3EQBL	Packing	4"	3"	1-3/8" – 10T	2-1/2"	5	14.00	12.37	13.12	7	0.44	0.56	12.13	6.50	19.25
		Packing	4"	3"	1-3/8" – 10T	3"	4	15.88	14.25	15.00	12	0.44	0.56	12.25	6.50	19.25
		Packing	4"	3"	1-3/8" – 10T	3"	3	17.75	16.12	16.88	12	0.44	0.56	12.13	6.50	19.25
	B3JQBM	Packing	4"	3"	1-1/2" – 10T	2-1/2"	5	14.00	12.37	13.12	7	0.44	0.56	10.75	7.00	20.50
		Packing	4"	3"	1-1/2" – 10T	3"	4	15.88	14.25	15.00	12	0.44	0.56	10.75	7.00	20.50
		Packing	4"	3"	1-1/2" – 10T	3"	3	17.75	16.12	16.88	12	0.44	0.56	10.75	7.00	20.50
		Packing	4"	3"	1-1/2" – 10T	3"	2	19.25	17.62	18.38	12	0.44	0.56	10.75	7.00	20.50
		Packing	4"	3"	1-1/2" – 10T	3"	1	21.75	20.12	20.88	12	0.47	0.56	10.75	7.00	20.50
	B3JQBMS	Mechanical	4"	3"	1-1/2" – 10T	3"	4	15.88	14.25	15.00	12	0.44	0.56	10.75	7.00	20.50
		Mechanical	4"	3"	1-1/2" – 10T	3"	3	17.75	16.12	16.88	12	0.44	0.56	10.75	7.00	20.50
		Dry Run	4"	3"	1-1/2" – 10T	3"	4	15.88	14.25	15.00	12	0.44	0.56	10.75	7.00	20.50
Dry Run		4"	3"	1-1/2" – 10T	3"	3	17.75	16.12	16.88	12	0.44	0.56	10.75	7.00	20.50	

SAE Mount Dimensions – Flywheel Housings

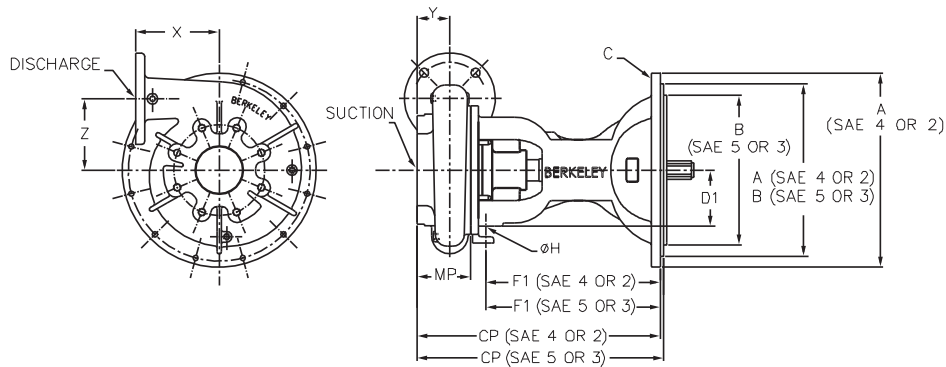

FLANGED (125# ANSI)

	PUMP MODEL	SHAFT SEAL	SUCTION	DISCHARGE	SHAFT SPLINE SIZE	CLUTCH SIZE	SAE () SHAFT EXT.	X	Y	MP	Z
	B3ZQM	Packing	4"	3"	1-1/2" – 10T	6.5	(4) 2-3/4"	6.81	2.86	4.40	5.88
		Packing	4"	3"	1-1/2" – 10T	7.5	(4) 2-3/4"	6.81	2.86	4.40	5.88
		Packing	4"	3"	1-1/2" – 10T	8	(4) 2-3/4"	6.81	2.86	4.40	5.88
		Packing	4"	3"	1-1/2" – 10T	10	(4) 2-3/4"	6.81	2.86	4.40	5.88
	B3ZQMS	Mechanical	4"	3"	1-1/2" – 10T	6.5	(4) 2-3/4"	6.81	2.86	4.40	5.88
		Mechanical	4"	3"	1-1/2" – 10T	7.5	(4) 2-3/4"	6.81	2.86	4.40	5.88
		Mechanical	4"	3"	1-1/2" – 10T	8	(4) 2-3/4"	6.81	2.86	4.40	5.88
		Mechanical	4"	3"	1-1/2" – 10T	10	(4) 2-3/4"	6.81	2.86	4.40	5.88
	B6ZQL	Packing	8"	6"	1-1/2" – 10T	6.5	(4) 2-3/4"	8.00	4.00	7.12	7.31
		Packing	8"	6"	1-1/2" – 10T	7.5	(4) 2-3/4"	8.00	4.00	7.12	7.31
		Packing	8"	6"	1-1/2" – 10T	8	(4) 2-3/4"	8.00	4.00	7.12	7.31
		Packing	8"	6"	1-1/2" – 10T	10	(4) 2-3/4"	8.00	4.00	7.12	7.31
	B6ZQLS	Mechanical	8"	6"	1-1/2" – 10T	6.5	(4) 2-3/4"	8.00	4.00	7.12	7.31
		Mechanical	8"	6"	1-1/2" – 10T	7.5	(4) 2-3/4"	8.00	4.00	7.12	7.31
		Mechanical	8"	6"	1-1/2" – 10T	8	(4) 2-3/4"	8.00	4.00	7.12	7.31
		Mechanical	8"	6"	1-1/2" – 10T	10	(4) 2-3/4"	8.00	4.00	7.12	7.31
B6ZQBM	Packing	8"	6"	1-1/2" – 10T	6.5	(4) 2-3/4"	8.00	4.00	7.12	7.31	
	Packing	8"	6"	1-1/2" – 10T	7.5	(4) 2-3/4"	8.00	4.00	7.12	7.31	
	Packing	8"	6"	1-1/2" – 10T	8	(4) 2-3/4"	8.00	4.00	7.12	7.31	
	Packing	8"	6"	1-1/2" – 10T	10	(4) 2-3/4"	8.00	4.00	7.12	7.31	
B6ZQBMS	Mechanical	8"	6"	1-1/2" – 10T	6.5	(4) 2-3/4"	8.00	4.00	7.12	7.31	
	Mechanical	8"	6"	1-1/2" – 10T	7.5	(4) 2-3/4"	8.00	4.00	7.12	7.31	
	Mechanical	8"	6"	1-1/2" – 10T	8	(4) 2-3/4"	8.00	4.00	7.12	7.31	
	Mechanical	8"	6"	1-1/2" – 10T	10	(4) 2-3/4"	8.00	4.00	7.12	7.31	

SAE Mount Dimensions – Flywheel Housings

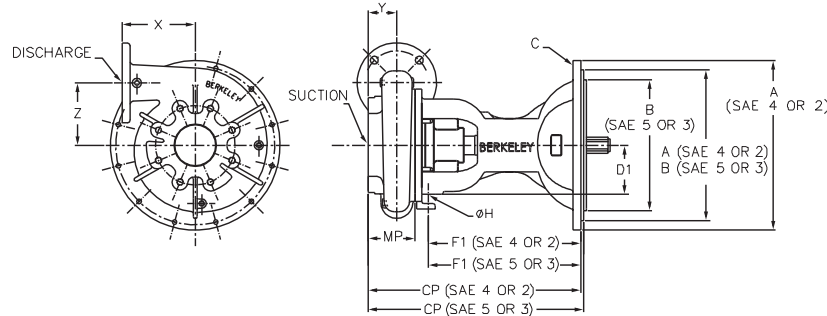

FLANGED (125# ANSI)

PUMP MODEL	SHAFT SEAL	SUCTION	DISCHARGE	SHAFT SPLINE SIZE	CLUTCH SIZE	SAE () SHAFT EXT.	A	B	C			DIA. H	F1	D1	CP
									BOLT CIRCLE	QTY. HOLES	HOLE SIZE				
B3ZQM	Packing	4"	3"	1-1/2"-10T	6.5	(4) 2-3/4"	16.00	14.25	15.00	12	0.44	NA	NA	NA	20.03
						(5) 2-1/2"	14.25	12.37	13.12	8	0.44	NA	NA	NA	20.28
	Packing	4"	3"	1-1/2"-10T	7.5	(4) 2-3/4"	16.00	14.25	15.00	12	0.44	NA	NA	NA	20.03
						(5) 2-1/2"	14.25	12.37	13.12	8	0.44	NA	NA	NA	20.28
B3ZQMS	Mechanical	4"	3"	1-1/2"-10T	6.5	(4) 2-3/4"	16.00	14.25	15.00	12	0.44	NA	NA	NA	20.03
						(5) 2-1/2"	14.25	12.37	13.12	8	0.44	NA	NA	NA	20.28
	Mechanical	4"	3"	1-1/2"-10T	7.5	(4) 2-3/4"	16.00	14.25	15.00	12	0.44	NA	NA	NA	20.03
						(5) 2-1/2"	14.25	12.37	13.12	8	0.44	NA	NA	NA	20.28
B6ZQL	Packing	8"	6"	1-1/2"-10T	6.5	(4) 2-3/4"	16.00	14.25	15.00	12	0.44	NA	NA	NA	22.75
						(5) 2-1/2"	14.25	12.37	13.12	8	0.44	NA	NA	NA	23.00
	Packing	8"	6"	1-1/2"-10T	7.5	(4) 2-3/4"	16.00	14.25	15.00	12	0.44	NA	NA	NA	22.75
						(5) 2-1/2"	14.25	12.37	13.12	8	0.44	NA	NA	NA	23.00
B6ZQLS	Mechanical	8"	6"	1-1/2"-10T	6.5	(4) 2-3/4"	16.00	14.25	15.00	12	0.44	NA	NA	NA	22.75
						(5) 2-1/2"	14.25	12.37	13.12	8	0.44	NA	NA	NA	23.00
	Mechanical	8"	6"	1-1/2"-10T	7.5	(4) 2-3/4"	16.00	14.25	15.00	12	0.44	NA	NA	NA	22.75
						(5) 2-1/2"	14.25	12.37	13.12	8	0.44	NA	NA	NA	23.00
B6ZQBM	Mechanical	8"	6"	1-1/2"-10T	6.5	(4) 2-3/4"	16.00	14.25	15.00	12	0.44	NA	NA	NA	22.75
						(5) 2-1/2"	14.25	12.37	13.12	8	0.44	NA	NA	NA	23.00
	Packing	8"	6"	1-1/2"-10T	7.5	(4) 2-3/4"	16.00	14.25	15.00	12	0.44	NA	NA	NA	22.75
						(5) 2-1/2"	14.25	12.37	13.12	8	0.44	NA	NA	NA	23.00
B6ZQBMS	Mechanical	8"	6"	1-1/2"-10T	6.5	(4) 2-3/4"	16.00	14.25	15.00	12	0.44	NA	NA	NA	22.75
						(5) 2-1/2"	14.25	12.37	13.12	8	0.44	NA	NA	NA	23.00
	Mechanical	8"	6"	1-1/2"-10T	7.5	(4) 2-3/4"	16.00	14.25	15.00	12	0.44	NA	NA	NA	22.75
						(5) 2-1/2"	14.25	12.37	13.12	8	0.44	NA	NA	NA	23.00
B6ZQBMS	Mechanical	8"	6"	1-1/2"-10T	6.5	(4) 2-3/4"	16.00	14.25	15.00	12	0.44	NA	NA	NA	22.75
						(5) 2-1/2"	14.25	12.37	13.12	8	0.44	NA	NA	NA	23.00
	Mechanical	8"	6"	1-1/2"-10T	7.5	(4) 2-3/4"	16.00	14.25	15.00	12	0.44	NA	NA	NA	22.75
						(5) 2-1/2"	14.25	12.37	13.12	8	0.44	NA	NA	NA	23.00
B6ZQBMS	Mechanical	8"	6"	1-1/2"-10T	6.5	(4) 2-3/4"	16.00	14.25	15.00	12	0.44	NA	NA	NA	22.75
						(5) 2-1/2"	14.25	12.37	13.12	8	0.44	NA	NA	NA	23.00
	Mechanical	8"	6"	1-1/2"-10T	7.5	(4) 2-3/4"	16.00	14.25	15.00	12	0.44	NA	NA	NA	22.75
						(5) 2-1/2"	14.25	12.37	13.12	8	0.44	NA	NA	NA	23.00
B6ZQBMS	Mechanical	8"	6"	1-1/2"-10T	6.5	(4) 2-3/4"	16.00	14.25	15.00	12	0.44	NA	NA	NA	22.75
						(5) 2-1/2"	14.25	12.37	13.12	8	0.44	NA	NA	NA	23.00
	Mechanical	8"	6"	1-1/2"-10T	7.5	(4) 2-3/4"	16.00	14.25	15.00	12	0.44	NA	NA	NA	22.75
						(5) 2-1/2"	14.25	12.37	13.12	8	0.44	NA	NA	NA	23.00
B6ZQBMS	Mechanical	8"	6"	1-1/2"-10T	6.5	(4) 2-3/4"	16.00	14.25	15.00	12	0.44	NA	NA	NA	22.75
						(5) 2-1/2"	14.25	12.37	13.12	8	0.44	NA	NA	NA	23.00
	Mechanical	8"	6"	1-1/2"-10T	7.5	(4) 2-3/4"	16.00	14.25	15.00	12	0.44	NA	NA	NA	22.75
						(5) 2-1/2"	14.25	12.37	13.12	8	0.44	NA	NA	NA	23.00
B6ZQBMS	Mechanical	8"	6"	1-1/2"-10T	6.5	(4) 2-3/4"	16.00	14.25	15.00	12	0.44	NA	NA	NA	22.75
						(5) 2-1/2"	14.25	12.37	13.12	8	0.44	NA	NA	NA	23.00
	Mechanical	8"	6"	1-1/2"-10T	7.5	(4) 2-3/4"	16.00	14.25	15.00	12	0.44	NA	NA	NA	22.75
						(5) 2-1/2"	14.25	12.37	13.12	8	0.44	NA	NA	NA	23.00
B6ZQBMS	Mechanical	8"	6"	1-1/2"-10T	6.5	(4) 2-3/4"	16.00	14.25	15.00	12	0.44	NA	NA	NA	22.75
						(5) 2-1/2"	14.25	12.37	13.12	8	0.44	NA	NA	NA	23.00
	Mechanical	8"	6"	1-1/2"-10T	7.5	(4) 2-3/4"	16.00	14.25	15.00	12	0.44	NA	NA	NA	22.75
						(5) 2-1/2"	14.25	12.37	13.12	8	0.44	NA	NA	NA	23.00
B6ZQBMS	Mechanical	8"	6"	1-1/2"-10T	6.5	(4) 2-3/4"	16.00	14.25	15.00	12	0.44	NA	NA	NA	22.75
						(5) 2-1/2"	14.25	12.37	13.12	8	0.44	NA	NA	NA	23.00
	Mechanical	8"	6"	1-1/2"-10T	7.5	(4) 2-3/4"	16.00	14.25	15.00	12	0.44	NA	NA	NA	22.75
						(5) 2-1/2"	14.25	12.37	13.12	8	0.44	NA	NA	NA	23.00
B6ZQBMS	Mechanical	8"	6"	1-1/2"-10T	6.5	(4) 2-3/4"	16.00	14.25	15.00	12	0.44	NA	NA	NA	22.75
						(5) 2-1/2"	14.25	12.37	13.12	8	0.44	NA	NA	NA	23.00
	Mechanical	8"	6"	1-1/2"-10T	7.5	(4) 2-3/4"	16.00	14.25	15.00	12	0.44	NA	NA	NA	22.75
						(5) 2-1/2"	14.25	12.37	13.12	8	0.44	NA	NA	NA	23.00

SAE Mount Dimensions – Flywheel Housings

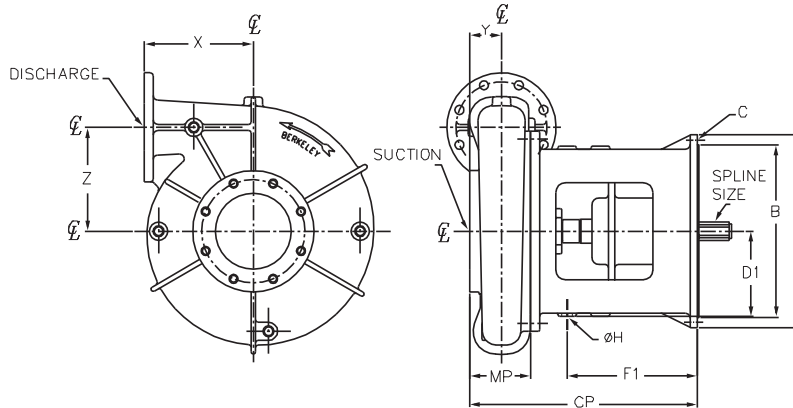

FLANGED (125# ANSI)

PUMP MODEL	SHAFT SEAL	SUCTION	DISCHARGE	SHAFT SPLINE SIZE	SHAFT EXT.	SAE HOUSING SIZE	X	Y	MP	Z
B4GQBH	Packing	5"	4"	1-1/2" – 10T	3"	4	9.88	3.64	6.15	8.25
	Packing	5"	4"	1-1/2" – 10T	3"	3	9.88	3.64	6.15	8.25
	Packing	5"	4"	1-1/2" – 10T	3"	2	9.88	3.64	6.15	8.25
	Packing	5"	4"	1-1/2" – 10T	3"	1	9.88	3.64	6.15	8.25
B4GQBHS	Mechanical	5"	4"	1-1/2" – 10T	3"	4	9.88	3.64	6.15	8.25
	Mechanical	5"	4"	1-1/2" – 10T	3"	3	9.88	3.64	6.15	8.25
	Mechanical	5"	4"	1-1/2" – 10T	3"	2	9.88	3.64	6.15	8.25
	Mechanical	5"	4"	1-1/2" – 10T	3"	1	9.88	3.64	6.15	8.25
	Dry Run	5"	4"	1-1/2" – 10T	3"	4	9.88	3.64	6.15	8.25
	Dry Run	5"	4"	1-1/2" – 10T	3"	3	9.88	3.64	6.15	8.25
	Dry Run	5"	4"	1-1/2" – 10T	3"	2	9.88	3.64	6.15	8.25
	Dry Run	5"	4"	1-1/2" – 10T	3"	1	9.88	3.64	6.15	8.25
B4JQBH	Packing	5"	4"	1-3/8" – 10T	3"	5	9.00	2.62	5.00	8.56
	Packing	5"	4"	1-3/8" – 10T	3"	4	9.00	2.62	5.00	8.56
	Packing	5"	4"	1-3/8" – 10T	3"	3	9.00	2.62	5.00	8.56
	Packing	5"	4"	1-3/8" – 10T	3"	2	9.00	2.62	5.00	8.56
	Packing	5"	4"	1-1/2" – 10T	3"	4	9.00	2.62	5.00	8.56
	Packing	5"	4"	1-1/2" – 10T	3"	3	9.00	2.62	5.00	8.56
	Packing	5"	4"	1-1/2" – 10T	3"	2	9.00	2.62	5.00	8.56
	Packing	5"	4"	1-1/2" – 10T	3"	1	9.00	2.62	5.00	8.56
B4JQBHS	Mechanical	5"	4"	1-1/2" – 10T	3"	3	9.00	2.62	5.00	8.56
	Mechanical	5"	4"	1-1/2" – 10T	3"	2	9.00	2.62	5.00	8.56
	Dry Run	5"	4"	1-1/2" – 10T	3"	3	9.00	2.62	5.00	8.56
	Dry Run	5"	4"	1-1/2" – 10T	3"	2	9.00	2.62	5.00	8.56
B4EXQBLS	Mechanical	5"	4"	1-1/2" – 10T	3"	3	9.38	3.38	5.81	9.50
	Mechanical	5"	4"	1-1/2" – 10T	3"	2	9.38	3.38	5.81	9.50
	Mechanical	5"	4"	1-1/2" – 10T	3"	1	9.38	3.38	5.81	9.50
B4EYQBM	Packing	5"	4"	1-1/2" – 10T	3"	4	12.00	5.25	7.63	10.50
	Packing	5"	4"	1-1/2" – 10T	3"	3	12.00	5.25	7.63	10.50
	Packing	5"	4"	1-1/2" – 10T	3"	2	12.00	5.25	7.63	10.50
	Packing	5"	4"	1-1/2" – 10T	3"	1	12.00	5.25	7.63	10.50
B4EYQBH	Packing	5"	4"	1-1/2" – 10T	3"	3	12.00	5.25	7.63	10.50
	Packing	5"	4"	1-1/2" – 10T	3"	2	12.00	5.25	7.63	10.50
	Packing	5"	4"	1-1/2" – 10T	3"	1	12.00	5.25	7.63	10.50
B4EYQBHS	Mechanical	5"	4"	1-1/2" – 10T	3"	3	12.00	5.25	7.63	10.50
	Mechanical	5"	4"	1-1/2" – 10T	3"	2	12.00	5.25	7.63	10.50
	Dry Run	5"	4"	1-1/2" – 10T	3"	3	12.00	5.25	7.63	10.50
	Dry Run	5"	4"	1-1/2" – 10T	3"	2	12.00	5.25	7.63	10.50
B5EQBH	Packing	6"	5"	1-3/8" – 10T	3"	4	9.50	3.94	6.56	6.94
	Packing	6"	5"	1-3/8" – 10T	3"	3	9.50	3.94	6.56	6.94
B5EQBHS	Mechanical	6"	5"	1-1/2" – 10T	3"	3	10.25	3.00	5.75	9.75
	Mechanical	6"	5"	1-1/2" – 10T	3"	2	10.25	3.00	5.75	9.75
	Mechanical	6"	5"	1-1/2" – 10T	3"	1	10.25	3.00	5.75	9.75
B6JQBL	Packing	8"	6"	1-3/8" – 10T	3"	4	11.00	3.00	5.88	8.75
	Packing	8"	6"	1-3/8" – 10T	3"	3	11.00	3.00	5.88	8.75

SAE Mount Dimensions – Flywheel Housings

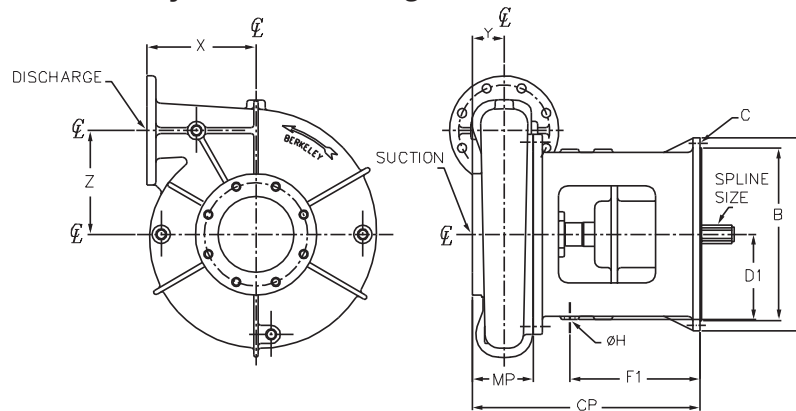

FLANGED (125# ANSI)

PUMP MODEL	SHAFT SEAL	SUCTION	DISCHARGE	SHAFT SPLINE SIZE	SHAFT EXT.	SAE HOUSING SIZE	A	B	C			DIA. H	F1	D1	CP
									BOLT CIRCLE	QTY. HOLES	HOLE SIZE				
B4GQBH	Packing	5"	4"	1-1/2"-10T	3"	4	15.88	14.25	15.00	12	0.44	0.56	10.75	7.00	19.90
	Packing	5"	4"	1-1/2"-10T	3"	3	17.75	16.12	16.88	12	0.44	0.56	10.75	7.00	19.90
	Packing	5"	4"	1-1/2"-10T	3"	2	19.25	17.62	18.38	12	0.44	0.56	10.75	7.00	19.90
	Packing	5"	4"	1-1/2"-10T	3"	1	21.75	20.12	20.88	12	0.47	0.56	10.75	7.00	19.90
B4GQBHS	Mechanical	5"	4"	1-1/2"-10T	3"	4	15.88	14.25	15.00	12	0.44	0.56	10.75	7.00	19.90
	Mechanical	5"	4"	1-1/2"-10T	3"	3	17.75	16.12	16.88	12	0.44	0.56	10.75	7.00	19.90
	Mechanical	5"	4"	1-1/2"-10T	3"	2	19.25	17.62	18.38	12	0.44	0.56	10.75	7.00	19.90
	Mechanical	5"	4"	1-1/2"-10T	3"	1	21.75	20.12	20.88	12	0.47	0.56	10.94	7.00	19.90
	Dry Run	5"	4"	1-1/2"-10T	3"	4	15.88	14.25	15.00	12	0.44	0.56	10.75	7.00	19.90
	Dry Run	5"	4"	1-1/2"-10T	3"	3	17.75	16.12	16.88	12	0.44	0.56	10.75	7.00	19.90
	Dry Run	5"	4"	1-1/2"-10T	3"	2	19.25	17.62	18.38	12	0.44	0.56	10.75	7.00	19.90
	Dry Run	5"	4"	1-1/2"-10T	3"	1	21.75	20.12	20.88	12	0.47	0.56	10.75	7.00	19.90
B4JQBH	Packing	5"	4"	1-3/8"-10T	3"	5	14.00	12.37	13.12	7	0.44	0.56	10.75	7.00	18.75
	Packing	5"	4"	1-3/8"-10T	3"	4	15.88	14.25	15.00	12	0.44	0.56	10.75	7.00	18.75
	Packing	5"	4"	1-3/8"-10T	3"	3	17.75	16.12	16.88	12	0.44	0.56	10.75	7.00	18.75
	Packing	5"	4"	1-3/8"-10T	3"	2	19.25	17.62	18.38	12	0.44	0.56	10.75	7.00	18.75
	Packing	5"	4"	1-1/2"-10T	3"	4	15.88	14.25	15.00	12	0.44	0.56	10.75	7.00	18.75
	Packing	5"	4"	1-1/2"-10T	3"	3	17.75	16.12	16.88	12	0.44	0.56	10.75	7.00	18.75
	Packing	5"	4"	1-1/2"-10T	3"	2	19.25	17.62	18.38	12	0.44	0.56	10.75	7.00	18.75
B4JQBHS	Mechanical	5"	4"	1-1/2"-10T	3"	3	17.75	16.12	16.88	12	0.44	0.56	10.75	7.00	18.75
	Mechanical	5"	4"	1-1/2"-10T	3"	2	19.25	17.62	18.38	12	0.44	0.56	10.75	7.00	18.75
	Dry Run	5"	4"	1-1/2"-10T	3"	3	17.75	16.12	16.88	12	0.44	0.56	10.75	7.00	18.75
	Dry Run	5"	4"	1-1/2"-10T	3"	2	19.25	17.62	18.38	12	0.44	0.56	10.75	7.00	18.75
B4EXQBLS	Mechanical	5"	4"	1-1/2"-10T	3"	3	17.75	16.12	18.38	12	0.44	0.56	11.50	7.00	19.31
	Mechanical	5"	4"	1-1/2"-10T	3"	2	19.25	17.62	18.38	12	0.44	0.56	11.50	7.00	19.31
	Mechanical	5"	4"	1-1/2"-10T	3"	1	21.75	20.12	20.88	12	0.47	0.56	11.50	7.00	19.31
B4EYQBM	Packing	5"	4"	1-1/2"-10T	3"	4	15.88	14.25	15.00	12	0.44	0.56	10.75	7.00	21.38
	Packing	5"	4"	1-1/2"-10T	3"	3	17.75	16.12	16.88	12	0.44	0.56	10.75	7.00	21.38
	Packing	5"	4"	1-1/2"-10T	3"	2	19.25	17.62	18.38	12	0.44	0.56	10.75	7.00	21.38
	Packing	5"	4"	1-1/2"-10T	3"	1	21.75	20.12	20.88	12	0.47	0.56	10.75	7.00	21.38
B4EYQBH	Packing	5"	4"	1-1/2"-10T	3"	3	17.75	16.12	16.88	12	0.44	0.56	10.75	7.00	21.38
	Packing	5"	4"	1-1/2"-10T	3"	2	19.25	17.62	18.38	12	0.44	0.56	10.75	7.00	21.38
	Packing	5"	4"	1-1/2"-10T	3"	1	21.75	20.12	20.88	12	0.47	0.56	10.75	7.00	21.38
B4EYQBHS	Mechanical	5"	4"	1-1/2"-10T	3"	3	17.75	16.12	16.88	12	0.44	0.56	10.75	7.07	21.38
	Mechanical	5"	4"	1-1/2"-10T	3"	2	19.25	17.62	18.38	12	0.44	0.56	10.75	7.00	21.38
	Dry Run	5"	4"	1-1/2"-10T	3"	3	17.75	16.12	16.88	12	0.44	0.56	10.75	7.00	21.38
	Dry Run	5"	4"	1-1/2"-10T	3"	2	19.25	17.62	18.38	12	0.44	0.56	10.75	7.00	21.38
B5EQBH	Packing	6"	5"	1-3/8"-10T	3"	4	15.88	14.25	15.00	12	0.44	0.56	12.25	6.50	19.56
	Packing	6"	5"	1-3/8"-10T	3"	3	17.75	16.12	16.88	12	0.44	0.56	12.13	6.50	19.56
B5EQBHS	Mechanical	6"	5"	1-1/2"-10T	3"	3	17.75	16.12	18.38	12	0.44	0.56	11.50	7.00	19.25
	Mechanical	6"	5"	1-1/2"-10T	3"	2	19.25	17.62	18.38	12	0.44	0.56	11.50	7.00	19.25
	Mechanical	6"	5"	1-1/2"-10T	3"	1	21.75	20.12	20.88	12	0.47	0.56	11.50	7.00	19.25
B6JQBL	Packing	8"	6"	1-3/8"-10T	3"	4	15.88	14.25	15.00	12	0.44	0.56	10.75	7.00	19.63
	Packing	8"	6"	1-3/8"-10T	3"	3	17.75	16.12	16.88	12	0.44	0.56	10.75	7.00	19.63

BRACKET DIMENSIONS

SAE Mount Dimensions – Flywheel Housings

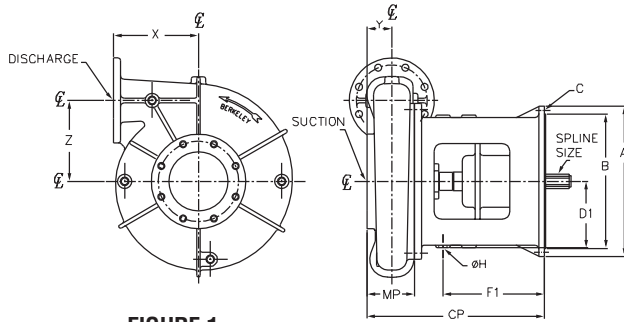

FIGURE 1

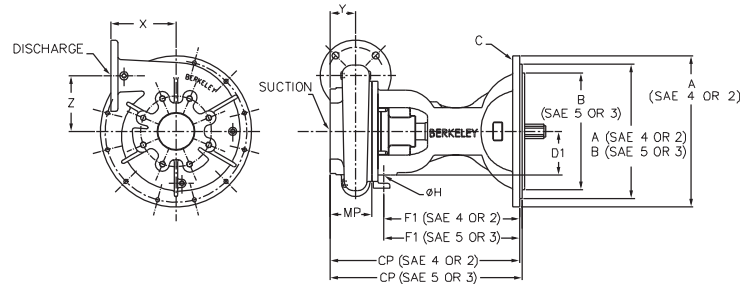

FIGURE 2

FLANGED (125# ANSI)

PUMP MODEL	SHAFT SEAL	SUCTION	DISCHARGE	FIGURE	SHAFT SPLINE SIZE	SHAFT EXT.	SAE HOUSING SIZE	X	Y	MP	Z
B6JQBM	Packing	8"	6"	1	1-1/2" - 10T	3"	4	12.00	3.97	6.85	10.50
	Packing	8"	6"	1	1-1/2" - 10T	3"	3	12.00	3.97	6.85	10.50
	Packing	8"	6"	1	1-1/2" - 10T	3"	2	12.00	3.97	6.85	10.50
	Packing	8"	6"	1	1-1/2" - 10T	3"	1	12.00	3.97	6.85	10.50
B6JQBMS	Mechanical	8"	6"	1	1-1/2" - 10T	3"	3	12.00	3.97	6.85	10.50
B6EXQBM	Packing	8"	6"	1	1-1/2" - 10T	3"	4	10.16	4.12	7.19	10.00
	Packing	8"	6"	1	1-1/2" - 10T	3"	3	10.16	4.12	7.19	10.00
	Packing	8"	6"	1	1-1/2" - 10T	3"	2	10.16	4.12	7.19	10.00
	Packing	8"	6"	1	1-1/2" - 10T	3"	1	10.16	4.12	7.19	10.00
B6XTQBH*	Packing	8"	6"	2	1-1/2" - 10T	3"	3 (ONE 2 UNIT)	12.00	5.13	8.20	12.00
	Packing	8"	6"	2	1-1/2" - 10T	2.44"	1	12.00	5.13	8.20	12.00
B6XTQBHS*	Dry Run	8"	6"	2	1-1/2" - 10T	3"	3 (ONE 2 UNIT)	12.00	5.13	8.20	12.00
	Dry Run	8"	6"	2	1-1/2" - 10T	3"	1	12.00	5.13	8.20	12.00
B6XTQBH**	Packing	8"	6"	2	1-1/2" - 10T	3"	3 (ONE 2 UNIT)	12.00	5.13	8.20	12.00
	Packing	8"	6"	2	1-1/2" - 10T	2.44"	1	12.00	5.13	8.20	12.00
B6XTQBHS**	Dry Run	8"	6"	2	1-1/2" - 10T	3"	3 (ONE 2 UNIT)	12.00	5.13	8.20	12.00
	Dry Run	8"	6"	2	1-1/2" - 10T	3"	1	12.00	5.13	8.20	12.00
B8GQBM	Packing	10"	8"	1	1-1/2" - 10T	3"	4	12.75	4.00	7.38	9.88
	Packing	10"	8"	1	1-1/2" - 10T	3"	3	12.75	4.00	7.38	9.88
	Packing	10"	8"	1	1-1/2" - 10T	3"	2	12.75	4.00	7.38	9.88
	Packing	10"	8"	1	1-1/2" - 10T	3"	1	12.75	4.00	7.38	9.88
B8GQBMS	Dry Run	10"	8"	1	1-1/2" - 10T	3"	4	12.75	4.00	7.38	9.88
	Dry Run	10"	8"	1	1-1/2" - 10T	3"	3	12.75	4.00	7.38	9.88
	Dry Run	10"	8"	1	1-1/2" - 10T	3"	2	12.75	4.00	7.38	9.88
	Dry Run	10"	8"	1	1-1/2" - 10T	3"	1	12.75	4.00	7.38	9.88
B10GQBM	Packing	12"	10"	1	1-1/2" - 10T	3"	3	12.88	4.37	8.50	9.59
	Packing	12"	10"	1	1-1/2" - 10T	3"	2	12.88	4.37	8.50	9.59
	Packing	12"	10"	1	1-1/2" - 10T	3"	1	12.88	4.37	8.50	9.59
B10GQBMS	Dry Run	12"	10"	1	1-1/2" - 10T	3"	3	12.88	4.37	8.50	9.59
	Dry Run	12"	10"	1	1-1/2" - 10T	3"	2	12.88	4.37	8.50	9.59
	Dry Run	12"	10"	1	1-1/2" - 10T	3"	1	12.88	4.37	8.50	9.59

*15.5" Trim

**14" Trim

SAE Mount Dimensions – Flywheel Housings

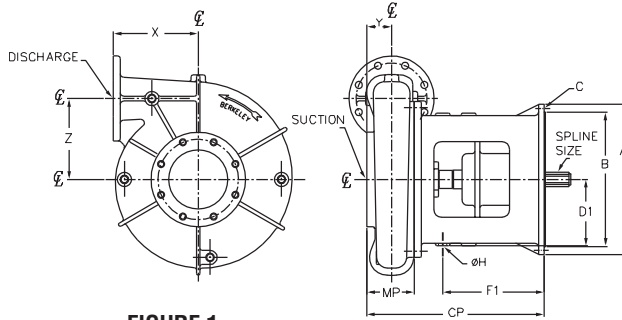

FIGURE 1

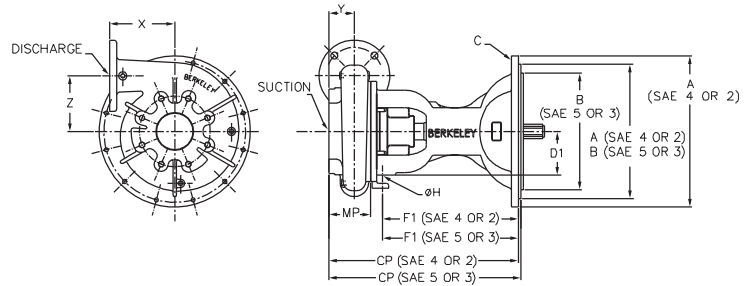

FIGURE 2

FLANGED (125# ANSI)

PUMP MODEL	SHAFT SEAL	SUCTION	DISCHARGE	FIGURE	SHAFT SPLINE SIZE	SHAFT EXT.	SAE HOUSING SIZE	A	B	C			DIA. H	F1	D1	CP
										BOLT CIRCLE	QTY. HOLES	HOLE SIZE				
B6JQBM	Packing	8"	6"	1	1-1/2"-10T	3"	4	15.88	14.25	15.00	12	0.44	0.56	10.75	7.00	20.60
	Packing	8"	6"	1	1-1/2"-10T	3"	3	17.75	16.12	16.88	12	0.44	0.56	10.75	7.00	20.60
	Packing	8"	6"	1	1-1/2"-10T	3"	2	19.25	17.62	18.38	12	0.44	0.56	10.75	7.00	20.60
	Packing	8"	6"	1	1-1/2"-10T	3"	1	21.75	20.12	20.88	12	0.47	0.56	10.75	7.00	20.60
B6JQBMS	Mechanical	8"	6"	1	1-1/2"-10T	3"	3	17.75	16.12	16.88	12	0.44	0.56	10.75	7.00	20.60
B6EXQBM	Packing	8"	6"	1	1-1/2"-10T	3"	4	15.88	14.25	15.00	12	0.44	0.56	10.75	7.00	20.94
	Packing	8"	6"	1	1-1/2"-10T	3"	3	17.75	16.12	16.88	12	0.44	0.56	10.75	7.00	20.94
	Packing	8"	6"	1	1-1/2"-10T	3"	2	19.25	17.62	18.38	12	0.44	0.56	10.75	7.00	20.94
	Packing	8"	6"	1	1-1/2"-10T	3"	1	21.75	20.12	20.88	12	0.47	0.56	10.75	7.00	20.94
B6XTQBH*	Packing	8"	6"	2	1-1/2"-10T	3"	3 (ONE 2 UNIT)	17.62	16.12	16.88	12	0.44	1/2" NPT	16.14	7.56	26.46
	Packing	8"	6"	2	1-1/2"-10T	2.44"	1	21.75	20.12	20.88	12	0.47	1/2" NPT	16.14	7.56	25.84
B6XTQBHS*	Dry Run	8"	6"	2	1-1/2"-10T	3"	3 (ONE 2 UNIT)	17.62	16.12	16.88	12	0.44	1/2" NPT	16.14	7.56	26.46
	Dry Run	8"	6"	2	1-1/2"-10T	3"	1	21.75	20.12	20.88	12	0.47	1/2" NPT	16.14	7.56	25.84
B6XTQBH**	Packing	8"	6"	2	1-1/2"-10T	3"	3 (ONE 2 UNIT)	17.62	16.12	16.88	12	0.44	1/2" NPT	16.14	7.56	26.46
	Packing	8"	6"	2	1-1/2"-10T	2.44"	1	21.75	20.12	20.88	12	0.47	1/2" NPT	16.14	7.56	25.84
B6XTQBHS**	Dry Run	8"	6"	2	1-1/2"-10T	3"	3 (ONE 2 UNIT)	17.62	16.12	16.88	12	0.44	1/2" NPT	16.14	7.56	26.46
	Dry Run	8"	6"	2	1-1/2"-10T	3"	1	21.75	20.12	20.88	12	0.47	1/2" NPT	16.14	7.56	25.84
B8GQBM	Packing	10"	8"	1	1-1/2"-10T	3"	4	15.88	14.25	15.00	12	0.44	0.56	10.75	7.00	21.13
	Packing	10"	8"	1	1-1/2"-10T	3"	3	17.75	16.12	16.88	12	0.44	0.56	10.75	7.00	21.13
	Packing	10"	8"	1	1-1/2"-10T	3"	2	19.25	17.62	18.38	12	0.44	0.56	10.75	7.00	21.13
	Packing	10"	8"	1	1-1/2"-10T	3"	1	21.75	20.12	20.88	12	0.47	0.56	10.75	7.00	21.13
B8GQBMS	Dry Run	10"	8"	1	1-1/2"-10T	3"	4	15.88	14.25	15.00	12	0.44	0.56	10.75	7.00	21.13
	Dry Run	10"	8"	1	1-1/2"-10T	3"	3	17.75	16.12	16.88	12	0.44	0.56	10.75	7.00	21.13
	Dry Run	10"	8"	1	1-1/2"-10T	3"	2	19.25	17.62	18.38	12	0.44	0.56	10.75	7.00	21.13
	Dry Run	10"	8"	1	1-1/2"-10T	3"	1	21.75	20.12	20.88	12	0.47	0.56	10.75	7.00	21.13
B10GQBM	Packing	12"	10"	1	1-1/2"-10T	3"	3	17.75	16.12	16.88	12	0.44	0.56	10.75	7.00	22.25
	Packing	12"	10"	1	1-1/2"-10T	3"	2	19.25	17.62	18.38	12	0.44	0.56	10.75	7.00	22.25
	Packing	12"	10"	1	1-1/2"-10T	3"	1	21.75	20.12	20.88	12	0.47	0.56	10.75	7.00	22.25
B10GQBMS	Dry Run	12"	10"	1	1-1/2"-10T	3"	3	17.75	16.12	16.88	12	0.44	0.56	10.75	7.00	22.25
	Dry Run	12"	10"	1	1-1/2"-10T	3"	2	19.25	17.62	18.38	12	0.44	0.56	10.75	7.00	22.25
	Dry Run	12"	10"	1	1-1/2"-10T	3"	1	21.75	20.12	20.88	12	0.47	0.56	10.75	7.00	22.25

*15.5" Trim

**14" Trim

SAE Mount Dimensions – Flywheel Housings

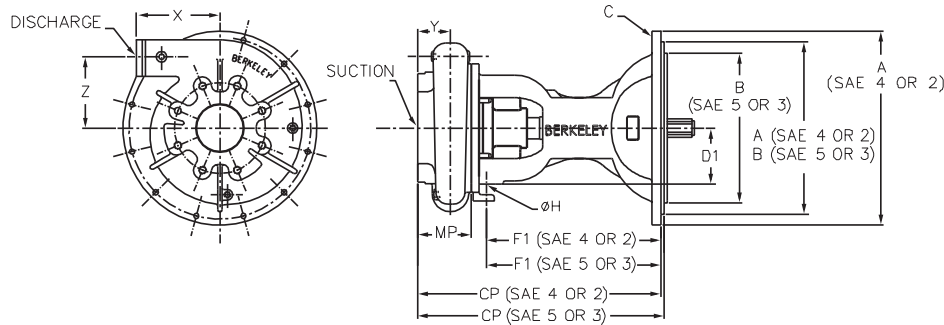

VICTAULIC

PUMP MODEL	SHAFT SEAL	SUCTION	DISCHARGE	SHAFT SPLINE SIZE	CLUTCH SIZE	SAE () SHAFT EXT.	X	Y	MP	Z
B3ZQM	Packing	4"	3"	1-1/2" – 10T	6.5	(4) 2-3/4"	6.88	3.50	5.25	4.38
	Packing	4"	3"	1-1/2" – 10T	7.5	(4) 2-3/4"	6.88	3.50	5.25	4.38
	Packing	4"	3"	1-1/2" – 10T	8	(4) 2-3/4"	6.88	3.50	5.25	4.38
	Packing	4"	3"	1-1/2" – 10T	10	(4) 2-3/4"	6.88	3.50	5.25	4.38
B3ZQMS	Mechanical	4"	3"	1-1/2" – 10T	6.5	(4) 2-3/4"	6.88	3.50	5.25	4.38
	Mechanical	4"	3"	1-1/2" – 10T	7.5	(4) 2-3/4"	6.88	3.50	5.25	4.38
	Mechanical	4"	3"	1-1/2" – 10T	8	(4) 2-3/4"	6.88	3.50	5.25	4.38
	Mechanical	4"	3"	1-1/2" – 10T	10	(4) 2-3/4"	6.88	3.50	5.25	4.38

PUMP MODEL	SHAFT SEAL	SUCTION	DISCHARGE	SHAFT SPLINE SIZE	CLUTCH SIZE	SAE () SHAFT EXT.	A		C			DIA. H	F1	D1	CP
							B	BOLT CIRCLE	QTY. HOLES	HOLE SIZE					
B3ZQM	Packing	4"	3"	1-1/2" – 10T	6.5	(4) 2-3/4"	16.00	14.25	15.00	12	0.44	NA	NA	NA	20.88
						(5) 2-1/2"	14.25	12.37	13.12	8	0.44	NA	NA	NA	21.13
	Packing	4"	3"	1-1/2" – 10T	7.5	(4) 2-3/4"	16.00	14.25	15.00	12	0.44	NA	NA	NA	20.88
						(5) 2-1/2"	14.25	12.37	13.12	8	0.44	NA	NA	NA	21.13
	Packing	4"	3"	1-1/2" – 10T	8	(4) 2-3/4"	16.00	14.25	15.00	12	0.44	NA	NA	NA	20.88
						(5) 2-1/2"	14.25	12.37	13.12	8	0.44	NA	NA	NA	21.13
	Packing	4"	3"	1-1/2" – 10T	10	(4) 2-3/4"	16.00	14.25	15.00	12	0.44	NA	NA	NA	20.88
						(5) 2-1/2"	14.25	12.37	13.12	8	0.44	NA	NA	NA	21.13
B3ZQMS	Mechanical	4"	3"	1-1/2" – 10T	6.5	(4) 2-3/4"	16.00	14.25	15.00	12	0.44	NA	NA	NA	20.88
						(5) 2-1/2"	14.25	12.37	13.12	8	0.44	NA	NA	NA	21.13
	Mechanical	4"	3"	1-1/2" – 10T	7.5	(4) 2-3/4"	16.00	14.25	15.00	12	0.44	NA	NA	NA	20.88
						(5) 2-1/2"	14.25	12.37	13.12	8	0.44	NA	NA	NA	21.13
	Mechanical	4"	3"	1-1/2" – 10T	8	(4) 2-3/4"	16.00	14.25	15.00	12	0.44	NA	NA	NA	20.88
						(5) 2-1/2"	14.25	12.37	13.12	8	0.44	NA	NA	NA	21.13
	Mechanical	4"	3"	1-1/2" – 10T	10	(4) 2-3/4"	16.00	14.25	15.00	12	0.44	NA	NA	NA	20.88
						(5) 2-1/2"	14.25	12.37	13.12	8	0.44	NA	NA	NA	21.13



CENTRIFUGAL PUMPS

B SERIES



CENTRIFUGAL PUMPS

B SERIES



Pentair
Water[™]

293 Wright Street | Delavan, WI 53115 | Phone: 1-888-BERKELEY | Fax: 1-800-426-9446 | www.berkeleypumps.com