



**NEW
IPT
REDESIGN**

Engine Driven Portable Trash Pump

*Cast Aluminum Self-Priming
Engine Driven Pumps*

- *Cast Aluminum with Cast Iron Wearparts*
- *Available with Honda, B&S Gasoline, or Yanmar Diesel Engines*
- *Removable Suction and Discharge Port Sizes: 2" and 3"*
- *Max. Flow: 200 to 300 GPM*
- *Max. Head: 105 to 115 ft.*
- *Max. Lift: 26 ft.*
- *Max. Solids Handling: 2S5- 1"; 3S5- 1.25"*
- *Silicon Carbide/Viton® Mechanical Seal*
- *Easy Clean Out with One Tool Serviceability*
- *EPDM O-Rings Standard; Optional Viton®**
- *Optional Wheel Kit*



Model 3S5XHR



Model 2S5XHR

High-volume self-priming centrifugal trash pumps come standard with a ductile iron impeller to resist abrasion and one tool serviceability for cleanout. All pumps feature aluminum housing, cast iron wearparts, built-in check valve, suction strainer and heavy duty steel frame. Standard Flanges with male NPT threads.

Many IPT Trash Pumps are readily available "Off-the-Shelf" for fast 24 hour shipment. For use with non-flammable liquids which are compatible with pump component materials.

*Viton® is a registered trademark of DuPont

COMMERCIAL DUTY

Performance of Trash Pump

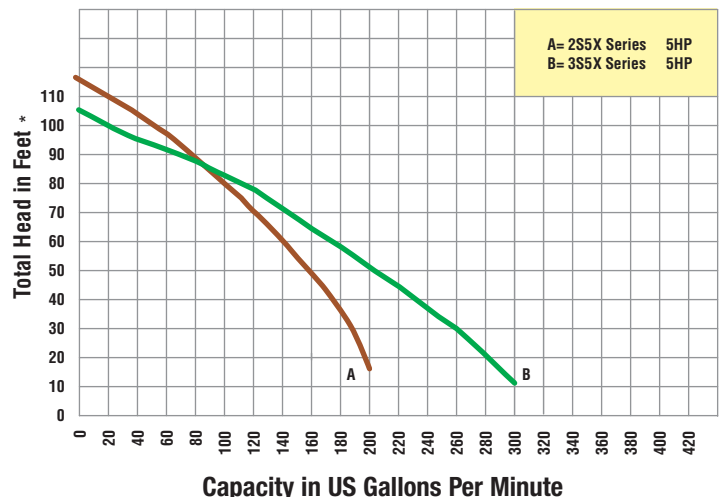

*Convert to PSI, divide by 2.31

Liquid-Water specific gravity 1.0

Portable Trash Pump

Standard Features

2" Trash Pumps (EPDM O-rings and Check Valve)

Alum. Model#	Ship Wt.	Curve	Ports	Driver	Seal	Run Time	Tank size
2S5XAR	87	A	2" NPT	B&S CP650	VITON®*/SIC-SIC	100 min.	3 qt.
2S5XHR	91	A	2" NPT	Honda GX160	VITON®*/SIC-SIC	100 min.	3.8 qt.
2S5XYR	112	A	2" NPT	Yanmar Diesel L48	VITON®*/SIC-SIC	110 min.	2.6 qt.

Maximum Solids Handling Capability: 1" Diameter

3" Trash Pumps (EPDM O-rings and Check Valve)

Alum. Model#	Ship Wt.	Curve	Ports	Driver	Seal	Run Time	Tank size
3S5XAR	96	B	3" NPT	B&S CP650	VITON®*/SIC-SIC	100 min.	3 qt.
3S5XHR	100	B	3" NPT	Honda GX160	VITON®*/SIC-SIC	100 min.	3.8 qt.
3S5XYR	121	B	3" NPT	Yanmar Diesel L48	VITON®*/SIC-SIC	110 min.	2.6 qt.

Maximum Solids Handling Capability: 1.25" Diameter

5/8 Threaded Kit (Single)

Alum. Model #	Alum. Ship Wt. (lbs.)	Seal Type & Elastomer /Faces	Mounting
2S5X	40	Viton®*/Sic/Sic	Handle
3S5X	46	Viton®*/Sic/Sic	Handle

*Viton® is a registered trademark of DuPont

- > Cast Iron Impeller
- > One Tool Serviceability, Tool Included with Engine Driven Models
- > Silicon Carbide, Self-Lubricated Seal with Graphite Impregnated Seat and EPDM Elastomers
- > Heavy Duty Steel Frame
- > Large Pump Casing
- > Built-In EPDM Check Valve
- > Removable/Replaceable Cast Iron Suction/Discharge Ports
- > Discharge Port Rotates in 90° Increments
- > Choice of Honda and Briggs & Stratton Gas or Yanmar Diesel Engines
- > Optional Wheel Kit Available
- > Strainer Included
- > Rubber Foot Mounting
- > Maximum Temperature 180°F
- > Optional Viton®* O-Ring / Check Valve Available
- > Pedestal Version Available

WARNING: Do not use in explosive atmosphere or for pumping volatile flammable liquids.

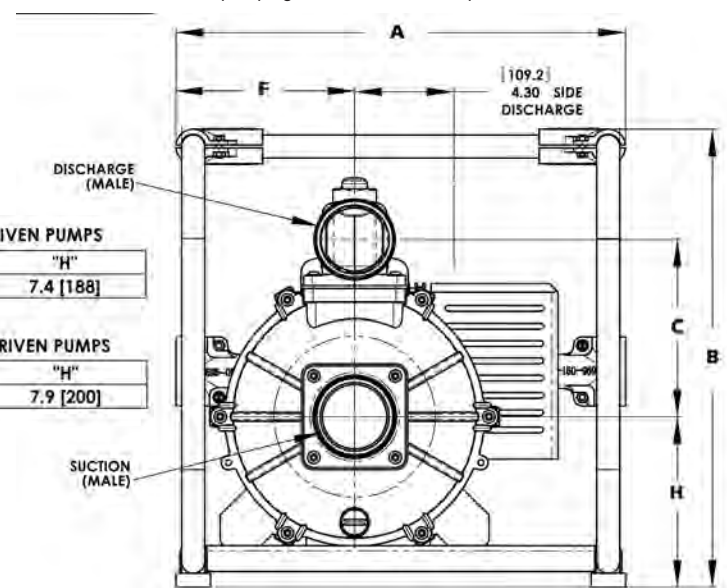
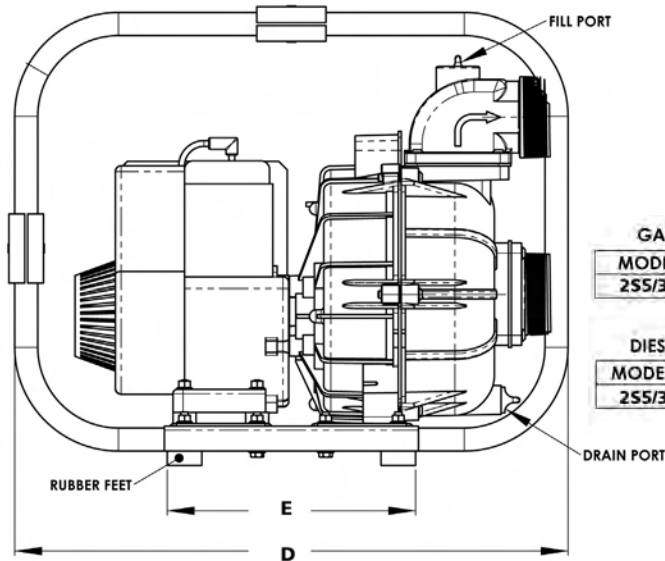

GAS ENGINE DRIVEN PUMPS	
MODEL - GAS	"H"
2S5/3S5X?R	7.4 [188]
DIESEL ENGINE DRIVEN PUMPS	
MODEL - DIESEL	"H"
2S5/3S5X?R	7.9 [200]

DIMENSIONS:
INCHES
[MILLIMETERS]

MODEL	A	B	C	D	E	F	DISCH*	SUCT*
2S5X	19.5 [495]	19.9 [505]	7.7 [195]	24 [610]	10.8 [274]	7.5 [190]	2.00	2.00
3S5X	19.5 [495]	19.9 [505]	7.7 [195]	24 [610]	10.8 [274]	7.5 [190]	3.00	3.00

(*) STANDARD NPT (MALE) PIPE THREAD



See price book page 4

The Gorman-Rupp Company reserves the right to discontinue any model or change specifications at any time without incurring any obligation.

CP13-14 / 1208