



SAFETY WARNINGS



BEFORE OPERATING OR INSTALLING THIS PUMP, READ THIS MANUAL AND FOLLOW ALL SAFETY RULES AND OPERATING INSTRUCTIONS.

SAFETY CAREFULLY READ THESE SAFETY MESSAGES IN THIS MANUAL AND ON PUMP.

CAUTION

- **DO NOT OPERATE THIS PUMP DRY!**
- Review instructions before operating.
- Wear ear protection to reduce objectionable noise.

WARNING

- Review chemical manufacturer's safety precautions before handling.
- Make sure all connections are tight.
- Do not breathe or ingest fumes or chemicals.
- Never use with flammable fluids.
- Turn off engine before servicing.
- If fuel is spilled, avoid creating any source of ignition until the fuel vapors have been cleaned up and removed.

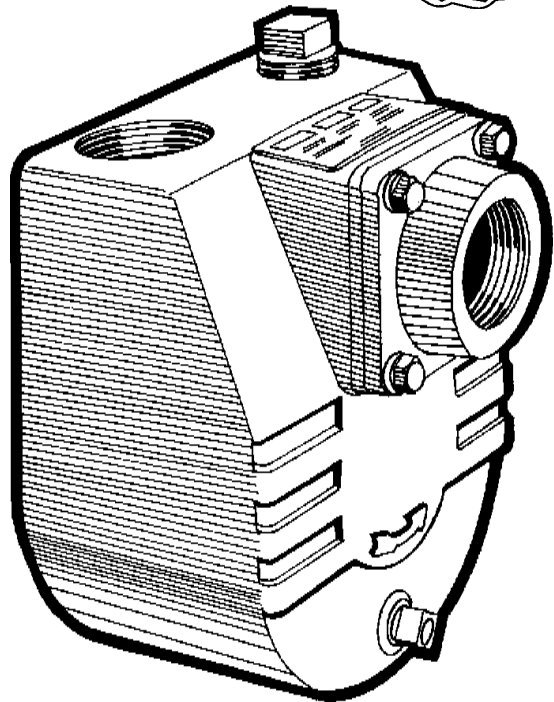

APPLICATION

Use these pumps on water or liquid fertilizer, where the vertical suction from the liquid level is 25 ft. (8m) or less.

The elevation above sea level, and friction losses, must be taken into consideration.

NOTE: Do not operate this pump dry for more than two minutes. This pump has been tested and operated under actual working conditions. Engine, pump and all accessories were found satisfactory. If pumping unit is not performing as specified, check installation and Troubleshooting Guide carefully.

INSTALLATION

Refer to Fig. 1

- a) **LOCATION:** For permanent installation, put the pump in a clean, dry and ventilated place. Keep the suction line as short as possible. This keeps pumping flow at its highest.
- b) **MOUNTING:** Mount the pump on a rigid foundation to eliminate creeping due to vibration.
- c) **SUCTION LINE:** Use a suction line the same size as the suction on the pump. If the suction pipe is long, increase it by one size to improve flow. Slope the suction line upwards to the pump to avoid air pockets in the line and hard priming.
- d) **SUCTION PIPE:** Use thread compound on all pipe joints. Connections must be tight. Clean, uncorroded pipe is recommended.

- e) **SUCTION HOSE:** If the suction line runs basically vertically, use an elbow on the hose to prevent kinking. Use double clamps on all hose joints. Connections must be tight.

NOTE: If you use the pump for dewatering, attach a foot valve to the suction line.

NOTE: The main cause of pumping problems is a leak in the suction line. Even a tiny leak reduces priming and pumping greatly.

OPERATION - PRIMING THE PUMP

WARNING: DO NOT RUN THE PUMP BEFORE PRIMING IT, SINCE THE SEAL AND IMPELLER COULD BE PERMANENTLY DAMAGED.

Refer to Fig. 1

- a) **PREPARING THE ENGINE:** Follow the engine manufacturer's instructions before operating.
- b) **PRIMING THE PUMP:** Remove the priming plug and fill the casing with the same liquid that you will be pumping and replace plug. If the pump is below the level of the liquid that will be pumped (flooded suction), the pump will automatically fill up when the valves are open. Then start the pump.

NOTE: DO NOT OPERATE THIS PUMP DRY!

- c) **START-UP:** In a 'flooded suction' situation, the pump will discharge the liquid almost immediately. If the suction line is above the liquid level being pumped, it will take a few minutes to lift the water to the casing and then to discharge it. If the suction line is quite long, the pump may overheat before the liquid in the suction line reaches the pump. In this case, turn the pump off and drain the casing. Wait a few minutes for the seal in the pump casing to cool down. Then replace the drain plug and refill the casing with the same liquid that will be pumped. Replace the priming plug and restart the pump.

WARNING

If the 'overheated' casing is filled while hot, damage to the seal will occur.

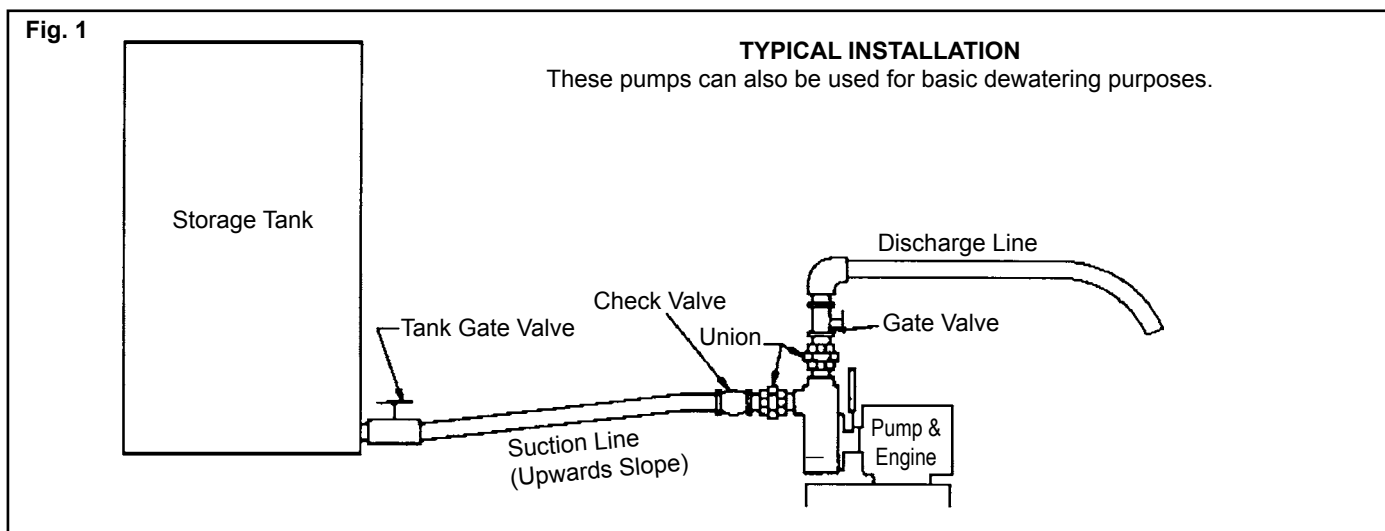

MAINTENANCE

- a) **ENGINE:** Refer to the engine manufacturer's instructions for any maintenance requirements.
- b) **FLUSHING:** If you are pumping chemicals, fertilizers or corrosive liquids, flush the pump after each use. Remove the drain and priming plugs and fill the casing several times with clean water.
- c) **DRAINING:** If the pump is subject to freezing temperatures, drain the pump by removing the drain plug and priming plug. After liquid has drained, run the pump for a few seconds to get the last liquid out of the impeller. Make sure the suction and discharge lines are free of liquid.

REPAIR

Refer to Fig. 2

DISASSEMBLY:

- 1) Drain the pump (see Draining under Maintenance).
- 2) Disconnect the pipes/hoses.
- 3) To remove the casing (1) remove the 6 nuts from the adapter.
- 4) To remove the impeller (2), remove bolt (12) and washer (13).
- 5) To remove the seal (8), simply pull it off of the shaft. The sleeve (10) will slide off with it.
- 6) Remove the adapter (6), by removing the 4 bolts.
- 7) To remove the ceramic seat (9), press it out from the backside of the adapter with your thumbs.
- 8) Remove the rubber cup (4) from the adapter.
- 9) **DO NOT REMOVE THE FLINGER (11)** unless it needs to be replaced.

REASSEMBLY:

- 1) Clean all parts thoroughly before reassembly.
- 2) Apply liquid soap to the outer surface of the rubber cup (4) on the stationary seat (9). Insert the stationary seal seat into the seal adapter plate. Make sure that the smooth face of the ceramic seat is facing towards the front of the pump. Push this assembly into the adapter, using hand pressure only.
- 3) Assemble the adapter (6) onto the engine using the bolts and new sealing washers. Make sure that the flinger (11) is on the shaft.

NOTE: There may be more than one position that the adapter can be bolted to the engine but only one position is correct.

IMPORTANT: Be careful not to damage the ceramic seat or shaft, when assembling the adapter to the engine.

- 4) Replace the Seal:
 - The sleeve (10) may have a chamfer on the inside diameter at one end only, or at both ends. If the chamfer is only on one end, the chamfer end must be towards the engine. Slide it onto the shaft.
 - Make sure both faces of the seal are clean, then slide seal (8) onto the sleeve.

- 5) Assemble impeller (2) and key onto engine shaft. Fasten with bolt and washer. Use thread locking compound on impeller bolt.

- 6) Replace the gasket (3) and the washers. Then assemble the casing onto the adapter.

PRECAUTION: Check to see that the impeller rotates freely in the casing.

- 7) Reconnect the suction and discharge lines. Use a thread compound and make sure that the connections are tight.

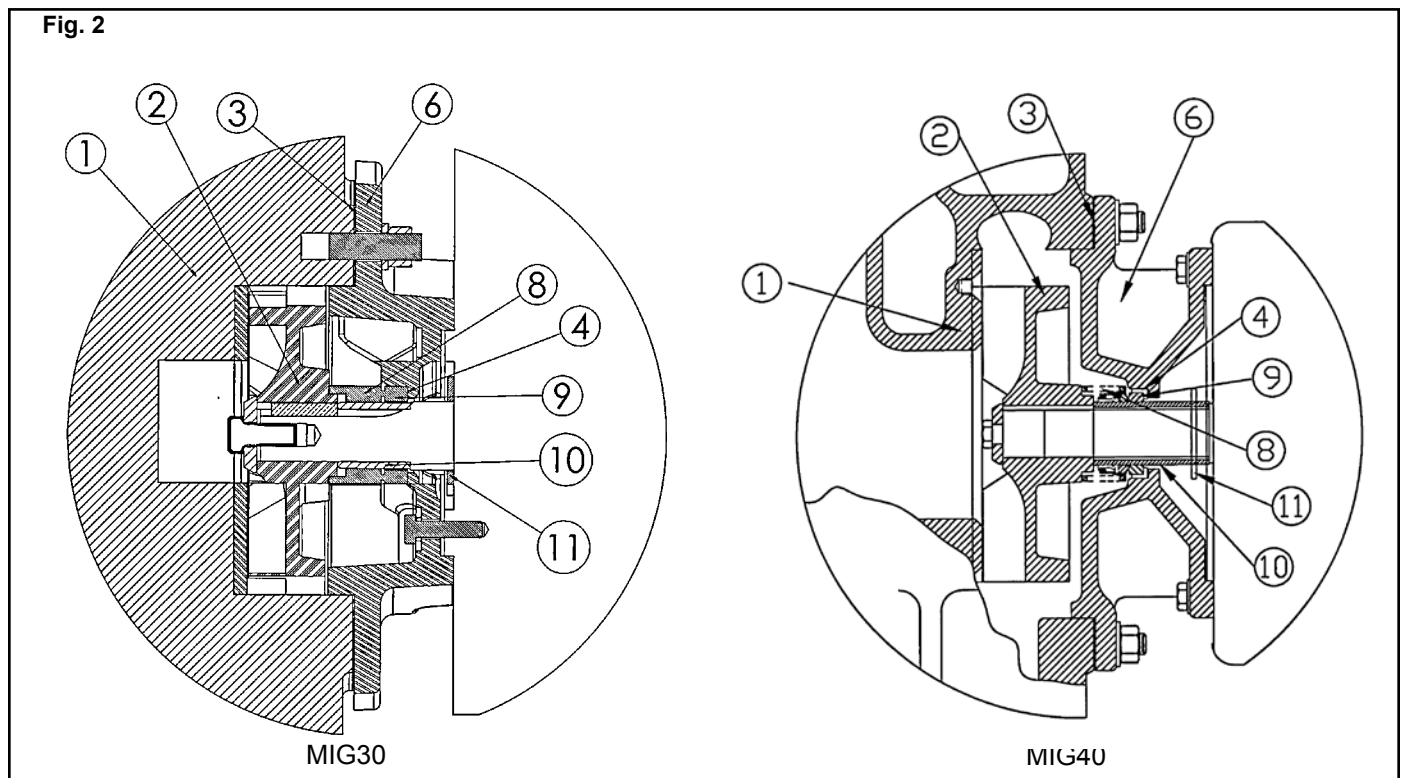

TROUBLESHOOTING CHART

PROBLEMS	CAUSES	SOLUTIONS
Pump will not pump	Air leak in suction line.	Make sure suction hose is double clamped at joints, clamps are tight, fittings have thread compound and are tight, no nicks or cuts in hose.
	The suction and/or discharge line(s) may be blocked, or the valve(s) are closed, faulty and/or blocked.	Check to see that the lines and valves are in good working order.
	The end of the suction line is not submerged.	Increase its length, or move the pump closer to the source of liquid.
Pump will not pump	Total head is too high for this pump to work against.	Reduce total head or use a higher head pump.
Pump doesn't catch prime	Excessive suction lift (*1).	Move the pump closer to liquid source.
Priming takes a long time	Suction line is quite long.	Refer to "start-up" under operation.
	Air pockets or leaks in the suction line.	Check the line for loose connections.
Pump does not perform as well as it should	Flow is restricted due to: a) Debris build-up. b) Faulty or semi-open valve(s). c) Piping/hosing used is smaller than the thread sizes on the pump.	a) Clean the lines and fittings. b) Check to see that the valves are in good working order c) Increase the size of hose/pipe to reduce friction losses
	Insufficient submergence of the end of the suction line.	The end of the suction line must be submerged.
	Excessively worn impeller (*2) and/or wear plate.	Replace impeller and/or wear plate.
	Seal is damaged (*3). Liquid will be leaking through the middle of the adapter.	Replace seal.
	Air pockets or leaks in the suction line.	Check suction line.
	Clogged impeller.	Remove casing to clean out.
Pump loses prime	Liquid level drops below the end of the suction line.	Increase length of suction line or move the pump closer to the liquid source.

***1)** Excessive suction lift must take into consideration:

- a)** Size and length of pipe
- b)** Density and temperature of liquid
- c)** Pipe fitting
- d)** Elevation above sea level

Including all of the above, we recommend that the total suction head not exceed 25 ft.

***2)** An excessively worn impeller is mainly caused from cavitation which is caused by a number of situations.

Examples:

- a)** Restricted suction
- b)** Excessive suction lift

***3)** The seal may be damaged due to:

- a)** Normal wear
- b)** Overheating
- c)** Pumping chemicals that this seal is not designed for

Contact a Monarch service depot for further assistance.

REPAIR PARTS LIST

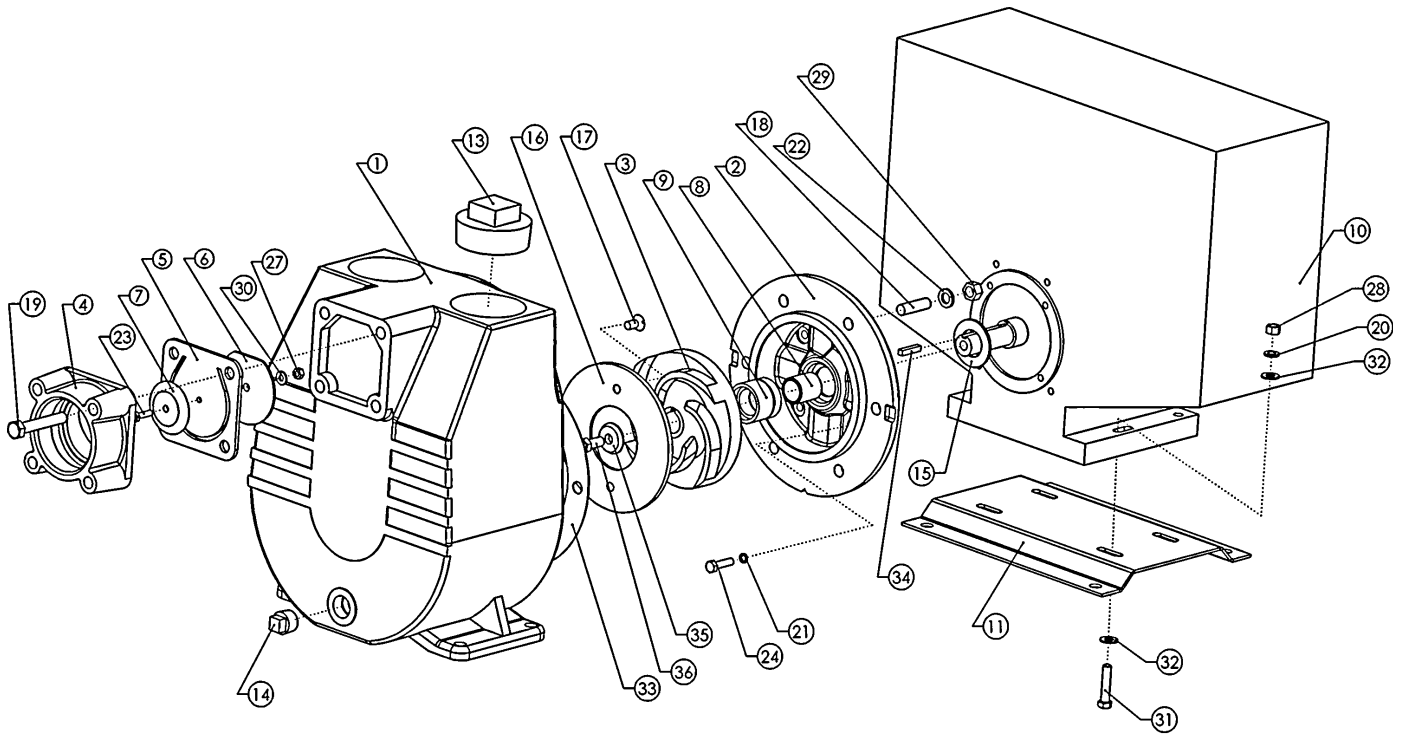

MIG-30

Models

a = MIG-30

b =MIG40-18K

c = MIG40-25K

d = MIG40-27K

Ref. #	Code #	Quantity Required for				Description
		a	b	c	d	
1	416630	1				Casing
1	419560		1	1	1	Casing
2	416662	1				Adapter
2	419632		1	1	1	Adapter
3	416658	1				Impeller
3	416659		1			Impeller
3	416657			1	1	Impeller
4	416660	1				Check Valve
4	419600		1	1	1	Check Valve
5	191380	1				Valve Rubber
5	191460		1	1	1	Valve Rubber
6	016670	1	1	1	1	Bottom Weight
7	013140	1				Top Weight
7	019610		1	1	1	Top Weight
8	266004	1				Sleeve
8	266013		1	1	1	Sleeve
9	240359	1				Mechanical Seal MS-59
9	240362		1	1	1	Mechanical Seal MS-62
10	201966	1				Engine B/S Vanguard 13 HP
10	202253		1			Engine Kohler 18 HP
10	202254			1		Engine Kohler 25 HP
10	202259				1	Engine Kohler 27 HP
11	432975	1				Base Plate
11	432968		1	1	1	Base Plate
12	432973	N/A	2	2	2	Channel
13	185810	1	1	1	1	Pipe Plug, 3" NPT
14	185650	1	1	1	1	Pipe Plug, 3/4" NPT Galv.
15	194140	1				Flinger
15	190846		1	1	1	Flinger
16	430420	1				Wear Plate
16	419710		1	1	1	Wear Plate
17	143980	2	3	3	3	Screw, 1/4" UNC x 3/4"
18	170641	6	6	6	6	Stud, 1/2" UNC x 1 3/4" ZP
19	226710	4				Bolt, 1/2" UNC x 3
19	227080		4	4	4	Bolt, 5/8" UNC x 2 3/4"
20	176230	4	4	4	4	Spring Washer, 3/8"
21	199001	4				Seal washer TW 5/16"
21	176240		4	4	4	Spring Washer, 7/16"
22	176250	6	14	14	14	Spring Washer, 1/2"
23	225751	1				Bolt, 1/4" UNC x 1
23	225980		1	1	1	Bolt, 5/16" UNC x 1

Ref. #	Code #	Quantity Required for				Description
		a	b	c	d	
24	225967	4				Bolt, 5/16" UNF x 1 1/4
24	226430		4	4	4	Bolt, 7/16" UNF x 1 1/4
25*	226630	N/A	4	4	4	Bolt, 1/2" UNC x 1
26*	226660	N/A	4	4	4	Bolt, 1/2" UNC x 1 3/4
27	128880	1				Nut, 1/4" UNC
27	227820		1	1	1	Nut, 5/16" UNC
28	227830	4	4	4	4	Nut, 3/8" UNC
29	227850	6	14	14	14	Nut, 1/2" UNC
30	174591	1	N/A	N/A	N/A	Plain washer, 1/4" SST
31	226240	4				Bolt, 3/8" UNC x 1 3/4
31	226230		4	4	4	Bolt, 3/8" UNC x 1 1/2
32	174986	8	N/A	N/A	N/A	Plain washer, 3/8
33	191390	1				Gasket
33	191480		1	1	1	Gasket
34	432082	1				Key 1/4 X 1 1/4
34	432090		1	1	1	Key 1/4 X 2
35	400197	1				Washer
35	400199		1	1	1	Washer
36	120239	1				Bolt, 7/16" UNF x 1
36	120261		1	1	1	Bolt, 7/16" UNF x 2

MONARCH INDUSTRIES
51 Burmac Road, P.O. Box 429
Winnipeg, Manitoba, Canada
R3C 3E4
Ph: (204) 786-7921
Fax: (204) 889-9120

E-mail: orders@monarchindustries.com (english)
commandes@monarchindustries.com (french)
www.monarchindustries.com

LIMITED MONARCH INDUSTRIES WARRANTY

For one year from date of purchase, Monarch Industries will replace or repair for the original purchaser, free of charge, any part or parts, found upon examination by any Monarch Industries Authorized Service Depot or by the Monarch factory, to be defective in material or workmanship or both. Equipment and accessories not manufactured by Monarch Industries are warranted only to the extent of the original manufacturer's warranty. All transportation charges on parts submitted for replacement or repair under this warranty must be borne by the purchaser. For warranty service see your nearest Monarch Industries Authorized Service Depot. THERE IS NO OTHER EXPRESS WARRANTY. IMPLIED WARRANTIES INCLUDING THOSE OF MERCHANTABILITY AND FITNESS FOR A PARTICULAR PURPOSE ARE LIMITED TO ONE YEAR FROM PURCHASE AND TO THE EXTENT PERMITTED BY LAW. LIABILITY FOR CONSEQUENTIAL DAMAGES UNDER ANY AND ALL WARRANTIES ARE EXCLUDED TO THE EXTENT EXCLUSION IS PERMITTED BY LAW.

This warranty is an addition to any statutory warranty.

