



STA-RITE®

OWNERS MANUAL

INSTALLATION AND OPERATING INSTRUCTIONS

U.S. Patent 5,133,639

Signature 2000®

Stainless Steel Series

Composite Series

4" SUBMERSIBLE PUMPS

Two and Three Wire

Single and Three Phase

1/2 through 10 H.P.

60 Hz

Record the following information from the motor and pump nameplates for future reference:

Pump Model No. _____

Pump Serial No. _____

Motor Model No. _____

Motor Serial No. _____

H.P. Volts/Hz/Ph _____

Rated Amp Draw _____

STA-RITE INDUSTRIES, INC.,

DELAVAN, WISCONSIN 53115

Carefully read and follow all safety instructions in this manual or on pump.

! This is the safety-alert. When you see this symbol on your pump or in this manual, look for one of the following signal words and be alert to the potential for personal injury:

⚠ DANGER warns about hazards that **will** cause serious personal injury, death or major property damage if ignored.

⚠ WARNING warns about hazards that **can** cause serious personal injury, death or major property damage if ignored.

⚠ CAUTION warns about hazards that **will** or **can** cause minor personal injury or property damage if ignored.

The word **NOTICE** indicates special instructions which are important but not related to hazards.

To avoid serious or fatal personal injury and possible property damage, carefully read and follow the safety instructions.

1. **⚠ WARNING** Hazardous pressure. Under certain conditions, submersible pumps can develop extremely high pressure. Install a pressure relief valve capable of passing entire pump flow at 75 PSI (517 kPa) when using an air over water pressure tank. Install a pressure relief valve capable of passing entire pump flow at 100 PSI (690 kPa) when using a pre-charged pressure tank.

⚠ Do not allow pump, pressure tank, piping, or any other system component containing water to freeze. Freezing may damage system, leading to injury or flooding. Allowing pump or system components to freeze will void warranty.

2. **⚠ WARNING** Hazardous voltage. Can shock, burn or cause death. To avoid dangerous or fatal electric shock hazard, use pump only in a water well.

⚠ Install, ground and wire pump according to local code and National Electrical Code requirements.

⚠ Disconnect electrical power supply before installing or servicing pump.

⚠ Make sure line voltage and frequency of power supply match motor nameplate voltage and frequency.

3. Install pump according to all plumbing, pump and well code requirements.
4. Test well water for purity before using well. Call your local health department for testing procedure.

5. During installation, keep well covered as much as possible to prevent leaves and foreign matter from falling into well. Foreign objects in well can contaminate the water and cause serious mechanical damage to the pump.
6. Pipe joint compound can cause cracking in plastics. Use only teflon tape when sealing joints in plastic pipe or connecting pipe to thermoplastic pumps.

TABLE OF CONTENTS

Safety Instructions	2
Pre-Installation	2
Electrical	2-12
Installation	13-17
Initial Startup	14-15
Connecting to Tank/Water System	16-17
Sand Boot Installation	18
Troubleshooting Guide	19-20
Warranty	21
Extended Warranty Application	22-24

PRE-INSTALLATION

Inspect pump and motor for delivery damage. Report any damage immediately to the shipping carrier or to your dealer.

The well driller should thoroughly develop the well (that is, pump out all fine sand and foreign matter) before pump is installed.

Pump performance is based on pumping clear, cold, liquid water.

Warranty is void in the following conditions:

- If pump has pumped excessive sand – excessive sand can cause premature wear to pump.
- If water is corrosive.
- If entrained gas or air are present in the water being pumped – these can reduce flow and cause cavitation which can damage pump.
- If pump has been operated with discharge valve closed – severe internal damage will result.

Install pump at least 15 to 20' (4.5 to 6M) below the lowest water level reached with pump running (lowest draw-down water level), and at least 5' (1.5M) above the bottom of the well.

WIRING/GROUNDING:

⚠ WARNING Hazardous voltage. Can shock, burn, or cause death. Permanently ground pump, motor and control box before connecting power supply to motor.

Ground pump and motor in accordance with the local codes and ordinances. Use a copper ground wire at least as large as wires carrying current to motor.

Motor is supplied with a copper ground wire. Splice this ground wire to a copper conductor that matches motor wire size specified in Table V. See Pages 13 and 14 for cable splicing instructions.

Permanently ground pump, motor and control box before connecting power cable to power supply. Connect ground wire to approved ground first and then connect to equipment being installed.

Do not ground to a gas supply line.

▲WARNING Fire and electrical shock hazard. If using a drop cable larger than No. 10 (5.5mm²) (for example, No. 8 (8.4mm²) wire) between pump and control box, run cable to a separate junction box. Connect junction box to control box with a No. 10 (5.5mm²) or smaller wire (depending on amp rating of pump – see Table II, III, or IV).

For more information, contact your local code officials.

WIRING CONNECTIONS:

All wiring must meet National Electrical Code or Canadian Electrical Code and local code requirements.

Use only copper wire when making connections to pump and control box.

To avoid over-heating wire and excessive voltage drop at motor, be sure that wire size is at least as large as size listed in Table V for your horsepower pump and length of wire run.

NOTICE: See Pages 8 through 12 for typical wiring hookups and control box identification.

NOTICE: When built-in overheating protection is not provided, use with an approved overload equipped motor control that matches motor input in full load amps. Select or adjust overload element(s) in accordance with control instructions. When built-in overheating protection is provided, use with an approved motor control that matches motor input in full load amperes.

Rotation – (3 Phase only)

To make sure motor is running in the right direction, proceed carefully as follows:

After electrical connections have been made as outlined, and with pump hanging in well supported from clamp on the discharge pipe, momentarily turn on then turn off the switch connecting the motor to the power supply line. Note rotation of pump as motor starts. If connections are properly made, pump will “jerk” clockwise when looking into the pump discharge when started. If “jerk” is counter-clockwise, the motor is running in the wrong direction.

Interchange any two cable leads where they connect to the “lead” terminals in the magnetic starter. With connections properly made, and pump lowered into water, turn on the switch again and the pump should deliver water according to the performance charts.

TABLE I – Overloads for 3 Phase 60 Hertz 4" Franklin Electric Motors

HP	KW	Volts	NEMA Starter Size	Heaters for Overload Relays			Adjustable Relays (Note 4)	
				Furnas (Note 1)	Allen Bradley (Note 2)	GE (Note 3)	Set	Max.
1.5	1.1	230	00	K39	J21	L680A	5.5	5.9
		460	00	K29	J15	L343A	2.8	3.0
		575	00	K26	J12	L282A	2.2	2.4
2	1.5	230	0	K49	J25	L910A	7.5	8.1
		460	00	K33	J18	L463A	3.8	4.1
		575	00	K29	J15	L380A	3.0	3.2
3	2.2	230	0	K52	J28	L122B	10.1	10.9
		460	0	K37	J21	L618A	5.1	5.5
		575	0	K34	J19	L510A	4.1	4.4
5	3.7	230	1	K61	J33	L199B	16.6	17.8
		460	0	K49	J26	L100B	8.3	8.9
		575	0	K42	J23	L825A	6.6	7.1
7.5	5.5	230	1	K67	J37	L293B	24.6	26.4
		460	1	K55	J30	L147B	12.3	13.2
		575	1	K52	J28	L122B	9.9	10.6
10	7.5	460	1	K61	J33	L220B	17.5	18.8
		575	1	K57	J31	L181B	14.0	15.0

OVERLOAD PROTECTION OF THREE PHASE SUBMERSIBLE MOTORS – CLASS 10 PROTECTION REQUIRED

The characteristics of submersible motors are different from standard motors and special overload protection is required.

If the motor is stalled, the overload protector must trip within 10 seconds to protect the motor windings. The installer must use SUBTROL or the quick-trip protection shown in these tables. All recommended overload selections are of the ambient compensated type to maintain protection at high and low air temperatures.

All heaters and amp settings shown are based on total line amps. When a six-lead motor is used with a Wye-Delta starter, divide motor amps by 1.732 to make your selection or adjustment for heaters carrying phase amps.

Table I lists the correct selection and settings for several manufacturers. Approval of other types may be requested from the motor manufacturer.

NOTICE: Warranty on three phase submersible motors is void unless proper quick trip protection in all three motor lines is used.

FOOTNOTES:

NOTE 1: Furnas intermediate sizes between NEMA starter sizes apply where (1) is shown in tables, size 1-3/4 replacing 2, 2-1/2 replacing 3, 3-1/2 replacing 4 and 4-1/2 replacing 5. Heaters were selected from Catalog 294, Table 332 and Table 632 (starter size 00, size B). Size 4 starters are heater type 4 (JG). Starters using these heater tables include classes 14, 17 and 18 (INNOVA), classes 36 and 37 (reduced voltage), and classes 87, 88 and 89 (pump and motor control centers). Overload relay adjustments should be set no higher than 100% unless necessary to stop nuisance tripping with measured amps in all lines below nameplate maximum. Heater selections for class 16 starters (Magnetic Definite Purpose) will be furnished upon request.

NOTE 2: Allen-Bradley heaters were selected from Catalog IC-110, Table 162 (through starter size 4), Table 547 (starter size 5), and Table 196 (starter size 6). Bulletin 505, 509, 520, 540 and 570 use these heater tables. Heater selections for bulletin 1232X and 1233X starters will be furnished upon request.

NOTE 3: General Electric heaters are type CR123 usable only on type CR124 overload relays and were selected from Catalog GEP-126O, page 184. Adjustment should be set no higher than 100%, unless necessary to stop nuisance tripping with measured amps in all lines below nameplate maximum.

NOTE 4: Adjustable overload relay amp settings apply to approved types listed. Relay adjustment should be set at the specified SET amps. Only if tripping occurs with amps in all lines measured to be within nameplate maximum amps should the setting be increased, not to exceed the MAX value shown.

RECOMMENDED ADJUSTABLE OVERLOAD RELAYS

AEG Series: B17S, B27S, B27-2.

Allen Bradley: Bulletin 193, SMP-Class 10 only.

Fanal Types: K7 or K7D through K400.

Franklin Electric: Subtrol-Plus.

General Electric: CR4G, CR7G, RT*1, RT*2, RTF3, RT*4, CR324X-Class 10 only.

Klockner-Moeller Types: Z00, Z1, Z4, PKZM1, PKZM3, PKZ2.

Lovato: RC9, RC22, RC80, RF9, RF25, RF95.

Siemens Types: 3UA50, -52, -54, -55, -58, -59, -60, -61, -62, -66, -68, -70, 3VUI3, 3VE, 3UB (Class 5).

Sprecher and Schuh Types: CT, CT1, CTA 1, CT3K, CT3-12 thru CT3-42, KTA3, CEF1 & CET3 set at 6 sec. max., CEP 7 Class 10, CT4, 6, & 7, CT3.

Square D/Telemecanique: Class 9065 types TD, TE, TF, TG, TJ, TK, TR, TJE, TJE (Class 10) or LR1-D, LR1-F, LR2-D13, -D23, -D33, Types 18A, 32A, SS-Class 10, SR-Class 10 and 63-A-LB Series. Integral 18,32,63, GV2-L, GV2-M, GV2-P, GV3-M (1.6-10 amp only).

Westinghouse Types: FT13, FT23, FT33, FT43, K7D, K27D, K67D, Advantage (Class 10), MOR, IQ500 (Class 5).

Other relay types from these and other manufacturers may or may not provide acceptable protection, and they should not be used without approval of Franklin Electric.

Some approved types may only be available for part of the listed motor ratings. When relays are used with current transformers, relay setting is the specified amps divided by the transformer ratio.

SURGE ARRESTERS IN CONTROL BOX

Grounding: When the box has a surge arrester, it **MUST** be grounded, metal to metal, all the way to the water strata for the arrester to be effective. Grounding the arrester to a driven ground rod provides little or no protection for the motor.

NOTICE: Surge arresters **DO NOT** protect against direct lightning strikes.

Install grounded surge arresters to protect pump from high voltage surges. Install arrester on the incoming power line to control box or pressure switch, as close to pump motor as possible. See Figures 1 and 2 for installation wiring diagrams for arresters.

NOTICE: Ground the arrester with a No. 10 or larger bare wire. Ground according to local code requirements.

NOTICE: If surge arresters wired into the control box are against local electrical code, contact power company for correct wiring information.

LIQUID LEVEL (PUMP DOWN)

CONTROLS:

Use pump down controls on wells with low flow to prevent pumping well dry. See Wiring diagrams, Pages 8 through 12, for proper installation.

NOTICE: Ground controls according to local code requirements.

TABLE II: Recommended Fusing Data - 60 Hz., Single Phase, 3 Wire Standard Submersible Pump Motors

HP	Volts/Hz/Ph	Motor Winding Resistance-Ohms R to Y B to Y		Max Load Amps	Locked Rotor Amps	Fuze Size Standard/Dual Element
1/2	115/60/1	4.1-5.1	1.0-1.3	12.0	50.5	35/20
1/2	230/60/1	16.7-20.5	4.2-5.2	6.0	23.0	20/10
3/4	230/60/1	11.0-13.4	3.0-3.6	8.0	34.2	25/15
1	230/60/1	10.1-12.3	2.2-2.7	9.8	41.8	30/20

Recommended Fusing Data - 60 Hz., Single Phase, 3 Wire Capacitor Run Submersible Pump Motors

HP	Volts/Hz/Ph	Motor Winding Resistance-Ohms R to Y B to Y		Max Load Amps	Locked Rotor Amps	Fuze Size Standard/Dual Element
1-1/2	230/60/1	6.2-12.0	1.5-2.3	11.5	52.0	35/20
2	230/60/1	5.2-7.15	1.6-2.3	13.2	51.0	30/20
3	230/60/1	3.0-4.9	0.9-1.5	17.0	82.0	45/30
5	230/60/1	2.1-2.8	0.68-1.0	27.5	121.0	80/45

Red to Yellow = start winding resistance;
Black to Yellow = main winding resistance.

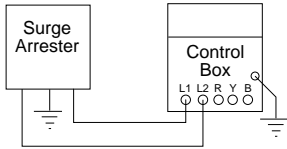

FIGURE 1 – Typical 3 Wire, Single Phase, 230 Volt Surge Arrester

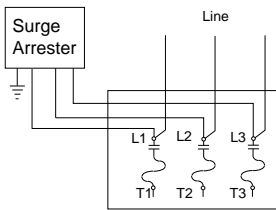

FIGURE 2 - Three Phase Surge Arrester (650 Volt Maximum)

TABLE III: Recommended Fusing Data - 60 Hz., Single Phase 2 Wire Submersible Pump Motors

HP	Volts/Hz/Ph	Motor Winding Resistance Ohms	Max Load Amps	Locked Rotor Amps	Fuze Size Standard/Dual Element
1/2	115/60/1	1.0-1.3	12.0	64.4	35/20
1/2	230/60/1	4.2-5.2	6.0	32.2	20/10
3/4	230/60/1	3.0-3.6	8.0	40.7	25/15
1	230/60/1	2.2-2.7	9.8	48.7	30/20
1-1/2	230/60/1	1.5-1.9	13.1	66.6	35/20

NOTE: 2 Wire motor leads are not color coded. Overload is located in motor and cannot be tested from above ground.

TABLE IV: Recommended Fusing Data - 60 Hz., 3 Phase Submersible Pump Motors

HP	Volts/Hz/Ph	Max Input (S.F. Load) Amps	Line to Line Resistance	Locked Rotor Amps	Fuze Size Standard/Dual Element
1-1/2	230/60/3	5.9	3.2-4.0	33.2	15/10
	460/60/3	3.0	13.0-16.0	16.6	8/5
	575/60/3	2.4	20.3-25.0	13.3	6/4
2	230/60/3	8.1	2.4-3.0	46.6	25/15
	460/60/3	4.1	9.7-12.0	23.3	15/8
	575/60/3	3.2	15.1-18.7	18.6	10/5
3	230/60/3	10.8	1.8-2.2	61.9	30/20
	460/60/3	5.4	7.0-8.7	31.0	15/10
	575/60/3	4.3	10.9-13.6	24.8	15/8
5	230/60/3	17.7	0.93-1.2	106.0	50/30
	460/60/3	8.9	3.6-4.4	53.2	25/15
	575/60/3	7.1	5.6-6.9	42.6	20/15
7-1/2	230/60/3	26.0	0.61-0.75	164.0	80/45
	460/60/3	13.0	2.4-3.4	81.9	40/25
	575/60/3	10.4	3.5-5.1	65.5	30/20
10	460/60/3	18.5	1.8-2.3	116.0	60/45
	575/60/3	14.8	2.8-3.5	92.8	45/35

TABLE V: Cable Length in Feet
1 Phase, 2 or 3 Wire Cable, 60 Hz. Copper Wire Size (Service to Motor)

Volts	HP	14	12	10	8	6	4	3	2	1	0
115V	1/2	100	160	250	390	620	960	1190	1460	1780	2160
230V	1/2	400	650	1020	1610	2510	3880	4810	5880	7170	8720
	3/4	300	480	760	1200	1870	2890	3580	4370	5330	6470
	1	250	400	630	990	1540	2380	2960	3610	4410	5360
	1-1/2	190	310	480	770	1200	1870	2320	2850	3500	4280
	2	150	250	390	620	970	1530	1910	2360	2390	3620
	3	120*	190	300	470	750	1190	1490	1850	2320	2890
	5	—	—	180	280	450	710	890	1110	1390	1740

3 Phase, 3 Wire Cable, 60 Hz.

Volts	HP	14	12	10	8	6	4	3	2	1	0
230V	1-1/2	420	670	1060	1670	2610	4050	5030	6160	7530	9170
	2	320	510	810	1280	2010	3130	3890	4770	5860	7170
	3	240	390	620	990	1540	2400	2980	3660	4480	5470
	5	140*	230	370	590	920	1430	1790	2190	2690	3290
	7-1/2	—	160*	260	420	650	1020	1270	1560	1920	2340
	10	—	—	190*	310	490	760	950	1170	1440	1760
460V	1-1/2	1700	2710	4270	6730	—	—	—	—	—	—
	2	1300	2070	3270	5150	8050	—	—	—	—	—
	3	1000	1600	2520	3970	6200	—	—	—	—	—
	5	590	950	1500	2360	3700	5750	—	—	—	—
	7-1/2	420	680	1070	1690	2640	4100	5100	6260	7680	—
	10	310	500	790	1250	1960	3050	3800	4650	5750	7050
575V	1-1/2	2620	4180	6580	—	—	—	—	—	—	—
	2	2030	3250	5110	8060	—	—	—	—	—	—
	3	1580	2530	3980	6270	5750	—	—	—	—	—
	5	920	1480	2330	3680	5750	—	—	—	—	—
	7-1/2	660	1060	1680	2650	4150	—	—	—	—	—
	10	490	780	1240	1950	3060	4770	5940	—	—	—

*Meets NEC for individual conductor 60°C cable. Only length without * meet NEC for jacketed 60°C cable. Local code requirements may vary.

Table V NOTES:

1. Maximum cable lengths shown maintain motor voltage at 95% of service entrance voltage, running at maximum nameplate amperes. If service entrance voltage will be at least motor nameplate voltage under normal load conditions, 50% additional length is permissible for all sizes.
2. Sizes given are for copper wire. For aluminum wire, go two sizes larger. For example, if table lists #12 (3mm²) copper wire, use #10 (5mm²) aluminum wire.
3. For reliable 3 Phase starter operation, length of wire between starter and service entrance should be not more than 25% of total wire length.

Calculating Cable size when two different sizes can be used.

Sometimes conditions make it desirable to use more than one size cable in an installation.

For example: Replace a pump with a 3 HP, 230 volt, single phase motor, with the motor setting at 310' down the well and with 160' of #10 cable buried between the service entrance and the well head. In order to avoid replacing the buried cable, the question is: What size cable is required in the well? Calculate as follows:

1. According to Table V, a total of 300' of #10 cable is allowed to power the 3 HP motor. The per cent of this total that has been used by the 160' of cable in the buried run is:
 $160'/300' = .533 = 53.3\%$.

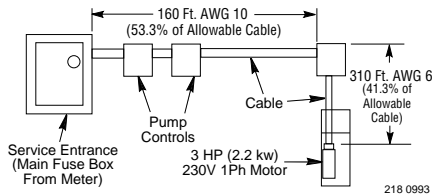

2. With 53.3% of the allowable cable already used, 46.7% of the total length is left for use in the well. To avoid running a cable that is too long and lowering the voltage to the motor, we have to find a cable size large enough so that 310' is less than 46.7% of the total length allowed for that size.

3. Trying #8 cable, Table V shows that the total allowable length for a 3 HP motor is 470'.
 $470' \times 46.7\% = 470' \times .467 = 219.5'$

This is not long enough.

4. Trying #6 cable, Table V shows that the total allowable length is 750'.

$$750' \times 46.7\% = 750' \times .467 = 350.25'$$

This is longer than needed. Therefore, #6 cable can be used for the 310' of cable in the well.

Any combination of sizes can be used, provided that the total percentage of the length of the two sizes of cable does not exceed 100% of the allowed lengths.

INSTALLATION WIRING DIAGRAMS - SINGLE PHASE, 3 WIRE

▲WARNING For motors of 1-1/2 HP and above, use magnetic starter to avoid damage to pressure switch. Consult factory for wiring information.

See Page 11 for 2 Wire Hookup

▲WARNING Hazardous voltage. Can shock, burn, or kill.

Ground control box, all metal plumbing, and motor frame with copper wire in compliance with local codes. Use a ground wire at least as large as the wires supplying power to motor.

Permanently close all unused openings in this and other equipment.

Disconnect power to control box before working on or around control box, pipes, cable, pump, or motor.

To be sure that starting relay will function and that overload will not "nuisance trip", install control box vertically with top side up.

Wire control box as shown on pages 8 through 12. Pump will not operate without control box, and deluxe boxes require a switch or a jumper lead between 'SW' and 'L2' terminals. Operation without control box will burn out motor.

Installation must include circuit and component protection which meet local code and United States National Electrical Code requirements.

If main overload trips, look for:

1. Shorted Capacitor
2. Voltage Problems
3. Overloaded or locked pump.

NOTICE: Match motor to control box as shown below. Franklin motor and control box model numbers may include additional suffix numbers to the right of the numbers shown here. These additional numbers are not important for control box selection.

TABLE VI: Control Box Selection

HP	Voltage	Motor No.	Control Box No.
1/2	115	214304 214504	28010449
1/2	230	214305 214505	28010549
3/4	230	214307 214507	28010749
1	230	214308 214508	28010849
1-1/2	230	224300	28230081
2	230	224301	28230181 28230183
3	230	224302	28230281 28230283
5	230	224303	28211381 28211383

If start overload or both overloads trip(s), replace start relay. Reset and analyze for tripping cause.

To avoid motor burnout, do not remove or short circuit overload protection.

CHECKING PROCEDURE (ALL BOXES):

⚠ DANGER Hazardous voltage. Can shock, burn, or cause death. Disconnect power to control box before doing these check procedures.

- A. General Procedures.** (Power to control box disconnected)
1. Disconnect line.
 2. Inspect for damaged or burned parts, loose connections, etc.
 3. Check for misconnections against diagram in control box.
 4. If box is too hot, circuit breakers may trip or fuses blow. Ventilate or shade box. Move away from heat source.
 5. If problem has not been found, check motor and control box. Use test procedures that follow.

- B. Ground (Insulation Resistance) Test.** (Power to control box disconnected)
1. Ohmmeter Setting: Highest scale (usually Rx100K or Rx10,000).
 2. Terminal Connections: One ohmmeter lead to "Ground" screw on control box and touch other lead to each of the terminals on terminal board.
 3. Ohmmeter Reading: Pointer should remain at infinity (∞) and not deflect.

C. Capacitor Tests. (Power to control box disconnected)

⚠ WARNING Risk of electric shock. Short capacitor across terminals before testing.

1. Ohmmeter Setting: Rx1000.
2. Terminal Connections: Connect ohmmeter leads to black and orange wires out of capacitor case.
3. Ohmmeter Reading: Pointer should swing toward "zero" and "float" back to (∞). Capacitor is shorted if pointer does not move back to (∞), open if it does not move from (∞).
4. To reset capacitor, reverse ohmmeter connection to capacitor terminals.

D. Triac Test. (Solid state switch only)

1. Ohmmeter Setting: Rx1000.
2. Connect the leads to "R" (start) terminal and to orange lead terminal on start switch.
3. Ohmmeter reading: Infinity (∞).

E. Coil Test. (Solid state switch only)

1. Ohmmeter Setting: Rx1.
2. Connect leads to "Y" (common) and L2 terminal and to orange lead terminal on start switch.
3. Ohmmeter reading: Infinity (∞).

Installation Wiring Diagrams – Single Phase, 3 Wire

⚠ WARNING For motors of 1-1/2 HP and above, use magnetic starter to avoid damage to pressure switch. Consult factory for wiring information.

SINGLE PHASE - 1/2 HP THRU 5 HP STANDARD CONTROL BOX WITH ADEQUATE RATED PRESSURE SWITCH

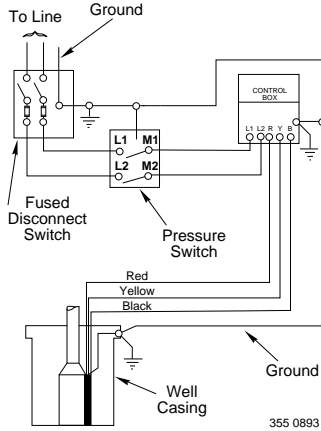

SINGLE PHASE - 1/2 HP THRU 5 HP STANDARD CONTROL BOX WITH PRESSURE SWITCH (One pump for 2 houses) With adequate rated pressure switch

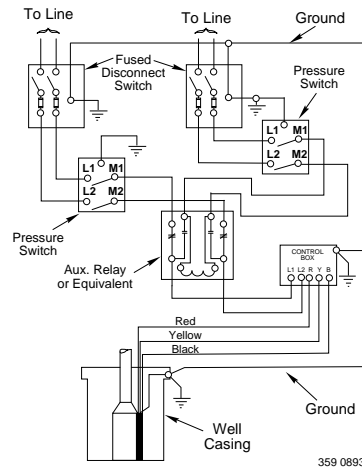

Follow color coding when connecting control box (Yellow to Y, Red to R, Black to B).

Installation Wiring Diagrams – Single Phase, 3 Wire

⚠ WARNING For motors of 1-1/2 HP and above, use magnetic starter to avoid damage to pressure switch. Consult factory for wiring information.

SINGLE PHASE - 1/2 HP THRU 5 HP STANDARD CONTROL BOX WITH LIQUID LEVEL CONTROL

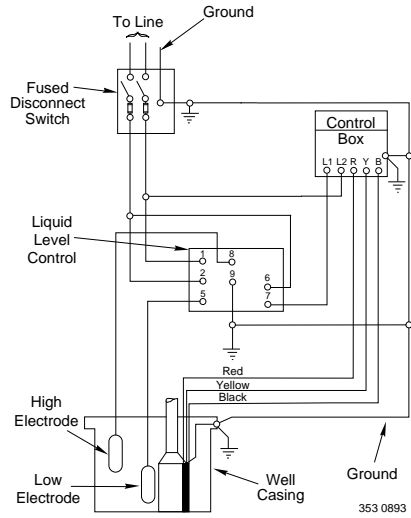

SINGLE PHASE - 1/2 HP THRU 5 HP STANDARD CONTROL BOX WITH PRESSURE SWITCH & LIQUID LEVEL CONTROL

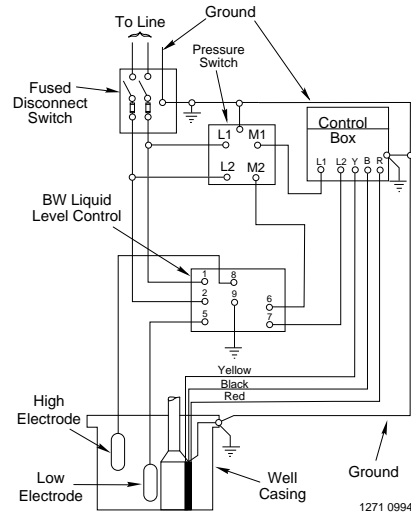

OPEN SYSTEM-SINGLE PHASE - 1/2 HP THRU 5 HP STANDARD CONTROL BOX

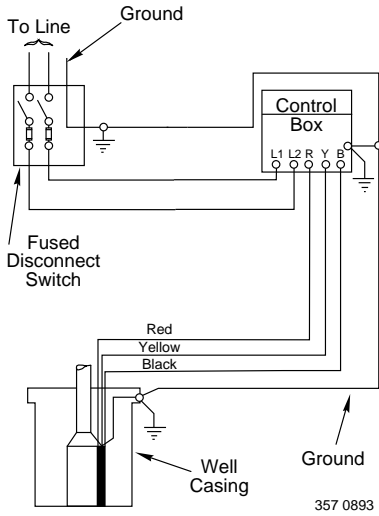

SINGLE PHASE - 2, 3 & 5 HP DELUXE CONTROL BOXES WITH PRESSURE SWITCH

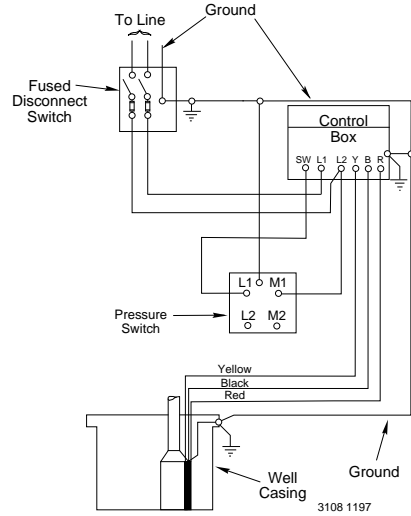

Follow color coding when connecting control box (Yellow to Y, Red to R, Black to B).

Installation Wiring Diagrams – Single Phase, 3 Wire

⚠ WARNING For motors of 1-1/2 HP and above, use magnetic starter to avoid damage to pressure switch. Consult factory for wiring information.

SINGLE PHASE - 2, 3 & 5 HP DELUXE CONTROL BOXES WITH LIQUID LEVEL CONTROL

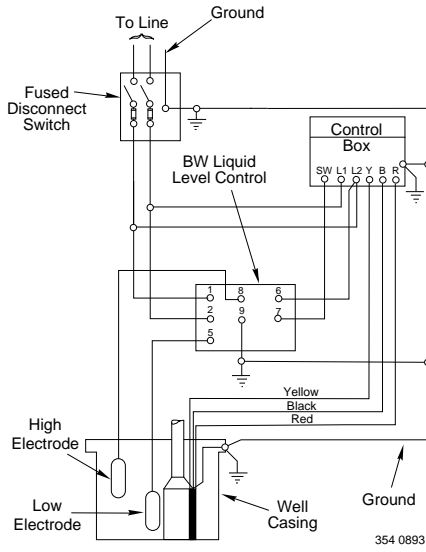

SINGLE PHASE - 2, 3 & 5 HP DELUXE CONTROL BOXES WITH PRESSURE SWITCH & LIQUID LEVEL CONTROL

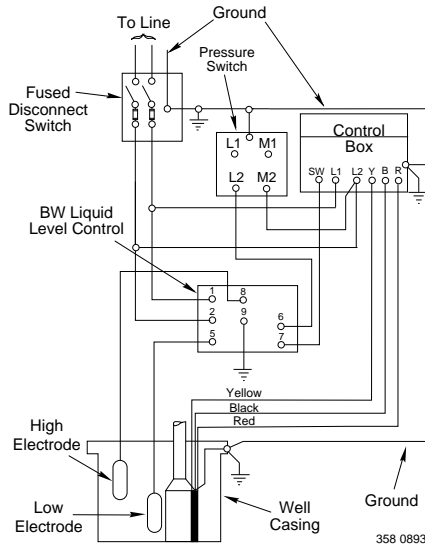

SINGLE PHASE - 2, 3 & 5 HP DELUXE CONTROL BOXES OPEN SYSTEM

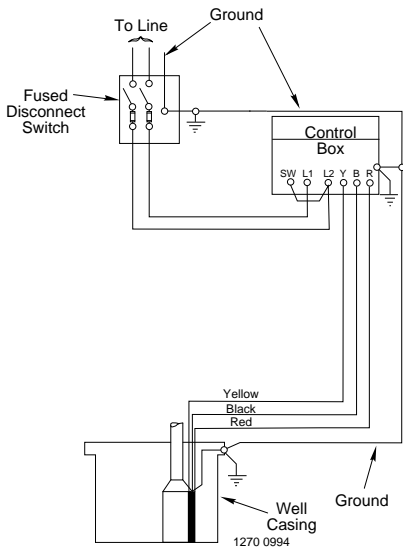

Follow color coding when connecting control box (Yellow to Y, Red to R, Black to B).

Installation Wiring Diagrams – Three Phase

⚠ WARNING For motors of 1-1/2 HP and above, use magnetic starter to avoid damage to pressure switch. Consult factory for wiring information.

THREE PHASE - 1-1/2 HP & LARGER
WITH PRESSURE SWITCH

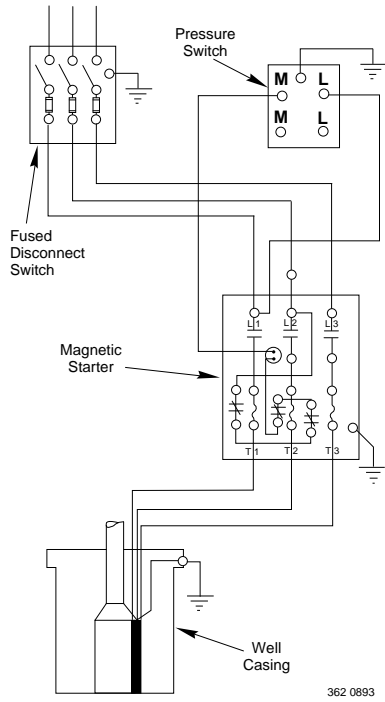

THREE PHASE - 1-1/2 HP & LARGER
WITH PRESSURE SWITCH &
LIQUID LEVEL CONTROL

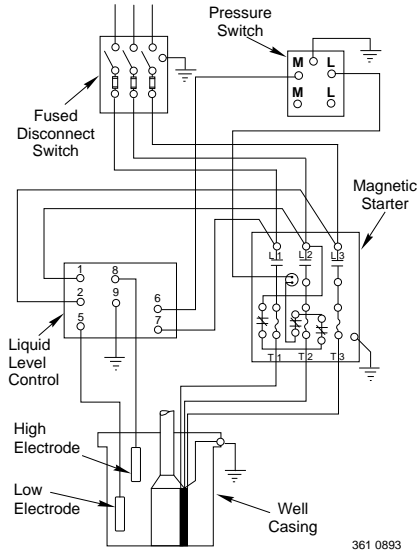

Follow color coding when connecting control box (Yellow to Y, Red to R, Black to B).

Installation Wiring Diagrams – Two Wire

⚠ WARNING For motors of 1-1/2 HP and above, use magnetic starter to avoid damage to pressure switch. Consult factory for wiring information.

WITH PRESSURE SWITCH
AND LIQUID LEVEL CONTROL

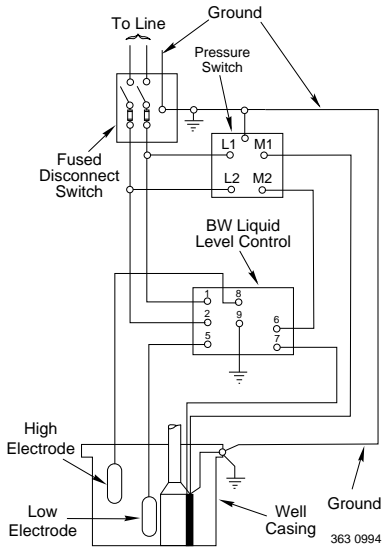

ONE PUMP FOR TWO HOUSES
WITH PRESSURE SWITCH

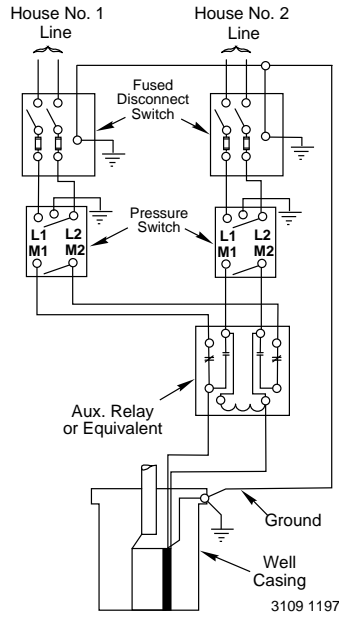

ONE PUMP FOR ONE HOUSE
WITH PRESSURE SWITCH

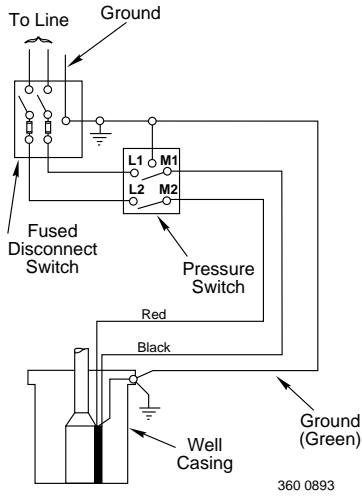

Follow color coding when connecting control box (Yellow to Y, Red to R, Black to B).

Installation

CABLE SPlicing:

1. Splice cable to motor leads. Use one of the three methods outlined below. Use only copper wire for connections to pump motor and control box.

A. Taped splice (Wire sizes No. 8 (8.4mm²) and larger):

1. Cut off motor leads. Stagger lead and wire length so that 2nd lead is 2" (50mm) longer than 1st lead and 3rd lead is 2" (50mm) longer than second.
2. Cut off cable ends. Be sure to match colors and lengths of wires in drop cable to colors and lengths of motor leads.
3. Trim insulation back 1/2" (13mm) from cable ends and motor lead ends.
4. Insert motor lead ends and cable ends into butt connectors (see Figure 4). Be sure to match wire colors between drop cable and motor leads.
5. Using crimping pliers (Figure 7), indent butt connector lugs (see Figure 5) to attach wires.

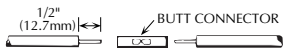

FIGURE 4



FIGURE 5



FIGURE 6

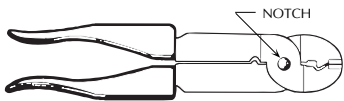

FIGURE 7



FIGURE 8

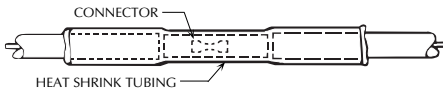

FIGURE 9

6. Cut "Scotchfil" electrical insulation putty into 3 equal parts and form tightly around butt connectors. Be sure scotchfil overlaps insulated part of wire.
7. Using #33 Scotch tape, wrap each joint tightly; cover wire for about 1-1/2" (38mm) on each side of joint. Make four passes with the tape. In other words, when finished you should have four layers of tape tightly wrapped around the wire. Press edges of tape firmly down against the wire (see Figure 8).

NOTICE: Since the tightly wound tape is the only means of keeping water out of the splice, the efficiency of the splice will depend on the care used in wrapping the tape.

NOTICE: For wire sizes larger than #8, (7mm²) use a soldered joint rather than Scotchfil putty (see Figure 6).

B. Heat-shrink splice (For wire sizes #14, 12 and 10 AWG, or 2, 3, and 5.5mm²):

1. Remove 3/8" (10mm) insulation from ends of motor leads and drop cable wires.
2. Put plastic heat shrink tubing over motor leads.
3. Match wire colors and lengths in drop cable to wire colors and lengths of motor leads.
4. Insert cable and motor wire ends into butt connectors and crimp (See Figures 4 and 5). **BE SURE** to match wire colors between drop cable and motor leads. Pull leads to check connections.
5. Center tubing over butt connector and apply heat evenly with a torch (a match

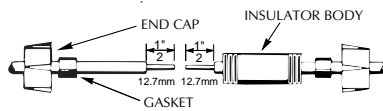

FIGURE 10

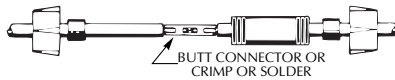

FIGURE 11

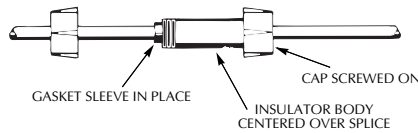

FIGURE 12

or lighter will not supply enough heat).
NOTICE: Keep torch moving. Too much concentrated heat may damage tubing (see Figure 9).

C. Butt Connectors with plastic insulators (for 14, 12 and 10 Gauge AWG Wire, or 2, 3 and 5.5mm² wire):

1. Cut off motor leads. Stagger lead and wire length so that 2nd lead is 4" (100mm) longer than 1st lead and 3rd lead is 4" (100mm) longer than second.
2. Cut off cable ends. Be sure to match colors and lengths of wires in drop cable to colors and lengths of motor leads.
3. Trim insulation back 1/2" (13mm) from cable ends and motor lead ends.
4. Unscrew plastic caps from insulators. Place a cap and a neoprene gasket sleeve on each wire end to be spliced (see Figure 10).
5. Slide insulator body onto one wire end (Fig. 10).
6. Insert wire end into butt connector and crimp (see Figure 11). **Be sure** to match cable and motor wire colors
7. Center insulator body over splice and slide neoprene sleeves into body as far as they will go. Screw caps onto insulator body (Figure 12) and tighten by hand for a strong, waterproof splice.

CABLE INSTALLATION

1. To test submersible, momentarily connect it to proper power supply. Power supply frequency and voltage must match motor nameplate frequency and voltage to within $\pm 10\%$. (3 Phase pumps – see "Rotation," Page 3).
2. Fasten cable leads securely to pump discharge section; leave 4-5" (100-127mm) of slack in leads at this point. Securely fasten leads to plastic pipe within 6" (150mm) of the pump discharge section. Use torque arresters to protect pump and pipe from twisting damage as pump starts and stops.
3. Connect copper ground wire to motor bracket. Ground wire must be at least as large as wires supplying current to motor. Consult local codes for grounding information.
4. Use only submersible cable supplied by pump manufacturer. When lowering pump into well, secure cable to discharge pipe at 10' (3.0M) intervals with Scotch #33 electrical tape. Take care not to damage pump cable.
NOTICE: To avoid dropping the pump down the well or damaging cable or cable splices, **NEVER** allow pump cable to support weight of pump.

PUMP INSTALLATION

1. If a standard air over water pressure tank is being used, install two bleeder orifices about 2' (.6M) apart as shown in Figure 15, Page 17. These orifices will automatically charge the tank with air. See Figure 15 to determine orifice location.
NOTICE: If Pre-charged tank is used, **DO NOT** install bleeder orifices. If pump and pre-charged tank are replacing a standard tank system, remove bleeder orifices before installing pump in well.
2. To prevent losing pump down the well, connect a safety rope strong enough to support pump and drop pipe (minimum 5/16" (8mm) twisted polypropylene or pronila rope) to eyelet on pump discharge. Tie off other end of safety rope securely to well seal, well cap or pitless adapter.
3. Discharge outlet is 1-1/4" NPT threaded. Use 100 PSI rated polyethylene plastic pipe for installations up to 100' depth. Use 160 PSI rated polyethylene plastic pipe for installation up to 220' depth. For depths beyond 220', use galvanized steel pipe for the entire drop pipe.

INITIAL START-UP

NOTICE: NEVER operate pump with discharge valve completely closed. Pump can destroy itself if run with discharge shut off ("deadheaded") and warranty will be void.

NOTICE: To avoid sand-locking pump, follow procedure below when starting pump for the first time. NEVER start a pump with discharge completely open unless you have done this procedure first.

1. Connect a pipe elbow, a short length of pipe and a gate valve to pump discharge at well head (see Figure 13).
2. Mount motor control box (3-wire pump), fused disconnect switch (2-wire pump), or magnetic starter (3-phase pump) in a permanently weather proofed place. Make sure that controls will not be subjected to extreme heat or excess moisture.
3. Make sure controls are in OFF position.
4. Connect motor leads and power supply to motor control box, fused disconnect switch, or magnetic starter (see Wiring Diagrams, Pages 8 through 12). **DO NOT START PUMP YET.**
5. Set gate valve on discharge 1/3 open; start pump (see Figure 13).
6. Keep gate valve at this setting while water pumps out on ground. Let it run until water is clear of sand or silt. (To check solids in water, fill a glass from pump and let solids settle out).

7. When water is completely clear at 1/3 setting, open gate valve to approximately two-thirds open and repeat process.
8. When water is completely clear at 2/3 setting, open gate valve completely and run pump until water is completely clear.
9. Remove gate valve for permanent installation near tank (see Figures 14 and 15, Pages 16 and 17).
10. Install sanitary well seal or pitless adapter unit, well unit, electrical conduit and surface piping according to local code requirements.

EFFLUENT APPLICATIONS

Pumps designed and tested for effluent applications must meet the following:

- ▲WARNING Risk of electric shock.** Do not remove cord and strain relief. Do not connect conduit to pump.
1. Only qualified personnel should install the pump and associated control equipment.
 2. Vent sewage or septic tank according to local codes.
 3. Do not install pump in any location classified as hazardous by National Electrical Code, ANSI/NFPA 70-1984.
 4. These pumps are intended for permanent connection only. Provide strain relief at control box for power supply cord connection to box. All control components must be UL listed and suitable for end use application.

CONNECTING TO TANK/WATER SYSTEM

▲WARNING Hazardous pressure. Submersible pumps can develop very high pressure in some situations. To prevent tank blowup, install a pressure relief valve able to pass full pump flow at 75 PSI (517kPa) when using an air over water pressure tank. Install a pressure relief valve capable of passing entire pump flow at 100 PSI (690 kPa) when using a pre-charged pressure tank. Install this relief valve between pump and tank.

NOTICE: Allowing pump or piping system to freeze may severely damage pump and will void warranty. Protect pump and entire piping system (including pressure tank) from freezing.

Standard Tank Hookup:

See Figure 15, Page 17 for piping connections to standard pressure tank and for correct distance of bleeder orifices from pressure tank.

Pre-charged Pressure Tank Hookup:

See Figure 14, Page 16 for piping connections to pre-charged pressure tank.

NOTICE: Check air pre-charge in tank before starting pump. Adjust pre-charge to 2 PSI below

pump cut-in setting. (For example, a pre-charge tank used with a 30-50 switch should be pre-charged with air to 28 PSI. Adjust pre-charge by either adding or bleeding air through tire valve located on top of tank. Check pre-charge annually and adjust as needed.

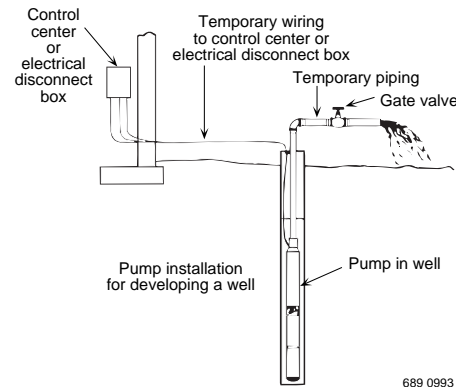

FIGURE 13

Important Electrical Grounding Information

▲WARNING Hazardous voltage. Can shock, burn, or kill. To reduce the risk of electrical shock during pump operation, ground and bond the pump and motor as follows:

- A. To reduce risk of electrical shock from metal parts of the assembly other than the pump, bond together all metal parts accessible at the well head (including metal discharge pipe, metal well casing, and the like). Use a metal bonding conductor at least as large as the power cable conductors running down the well to the pump's motor.
- B. Clamp or weld (or both if necessary) this bonding conductor to the grounding means provided with the pump, which will be the equipment-grounding terminal, the grounding conductor on the pump housing, or an equipment-grounding lead. The equipment-grounding lead, when provided, will be the conductor having green insulation; it may also have one or more yellow stripes.
- C. Ground the pump, motor, and any metallic conduit that carries power cable conductors. Ground these back to the service by connecting a copper conductor from the pump, motor, and conduit to the grounding screw provided within the supply-connection box wiring compartment. This conductor must be at least as large as the circuit conductors supplying the pump.

Save these instructions.

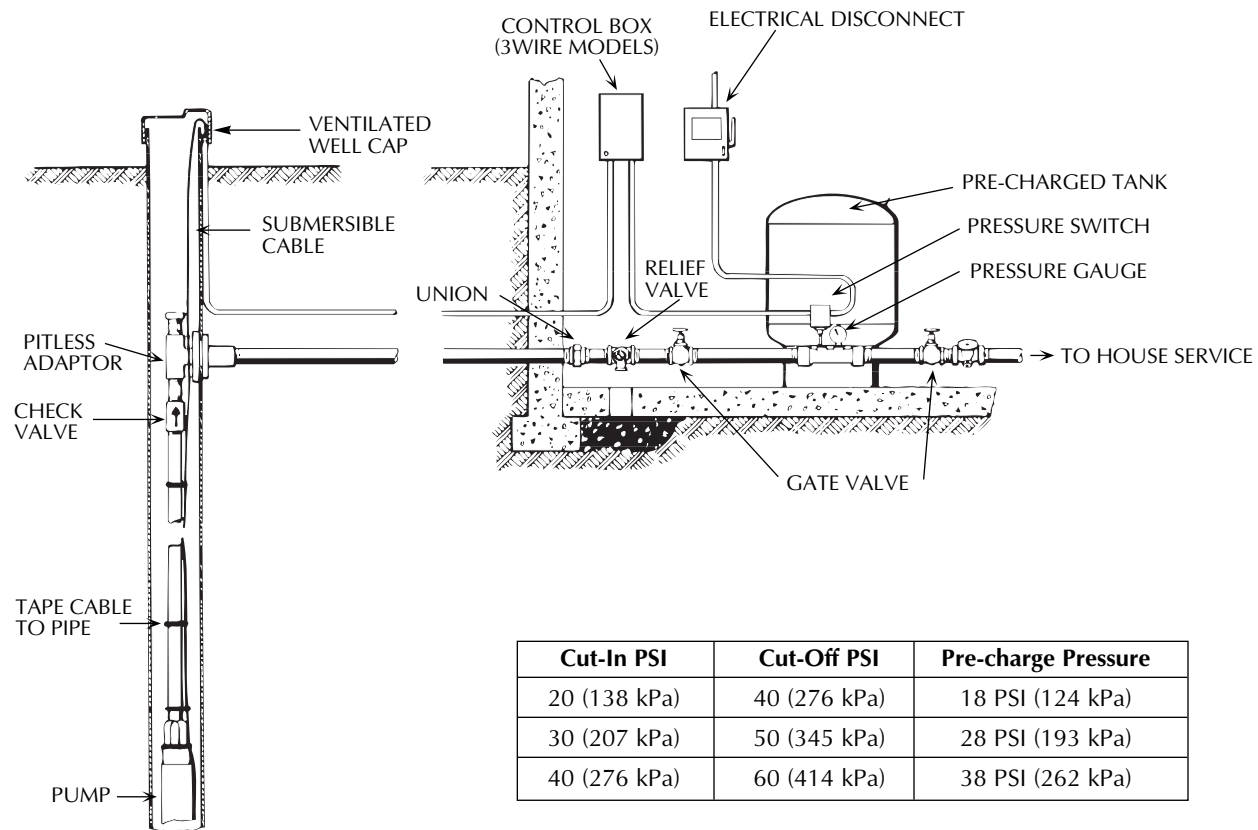
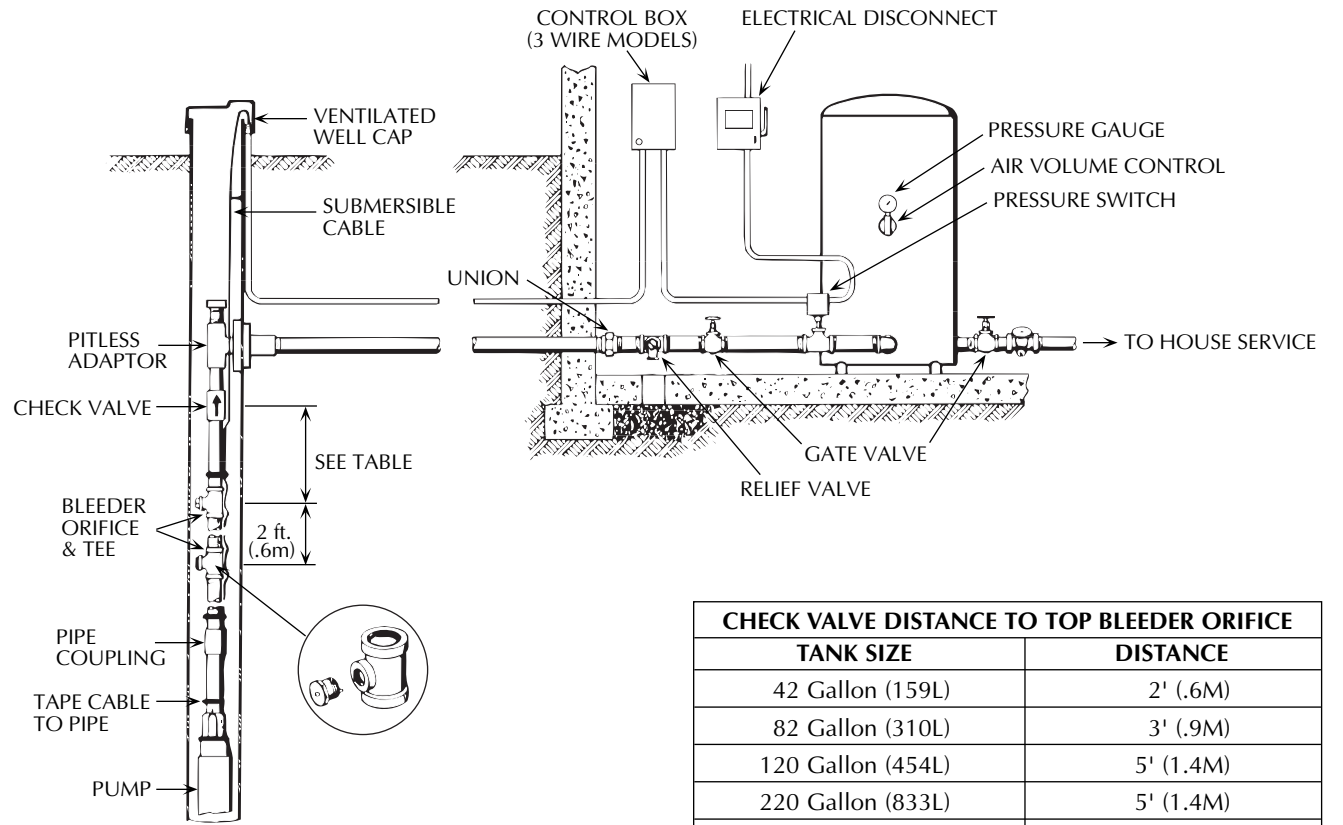

FIGURE 14 – Typical Submersible Installation with Pre-charged Tan



CHECK VALVE DISTANCE TO TOP BLEEDER ORIFICE	
TANK SIZE	DISTANCE
42 Gallon (159L)	2' (.6M)
82 Gallon (310L)	3' (.9M)
120 Gallon (454L)	5' (1.4M)
220 Gallon (833L)	5' (1.4M)
315 Gallon (1192L)	10' (3.0M)
525 Gallon (1987L)	15' (4.6M)

FIGURE 15 – Standard Pressure Tank Installation

Sand Boot Replacement

INSTALLATION INSTRUCTIONS

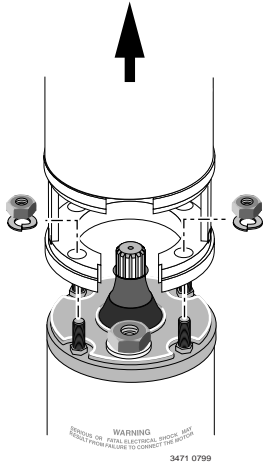

Step 1: Remove liquid end from motor (retrofits only).

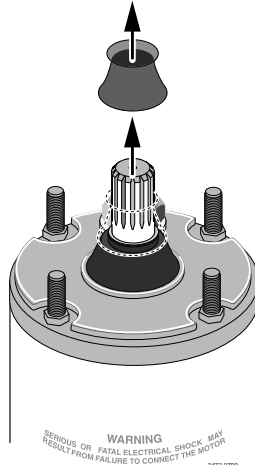

Step 2: Remove Franklin sand boot from motor shaft.

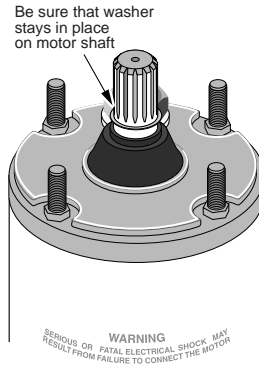

Step 3: Make sure that washer stays in place on motor shaft.

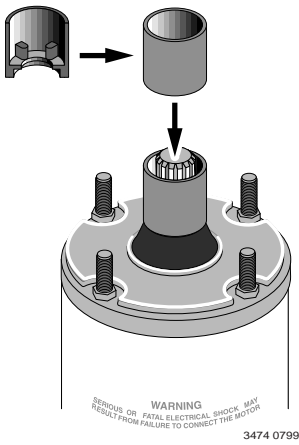

Step 4: Install the new sand boot, short end first, on motor shaft.

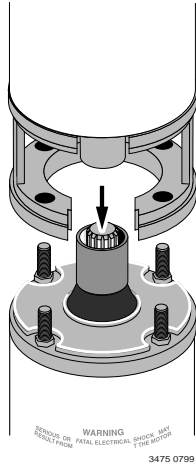

Step 5: Install liquid end on motor, working coupling down into new sand boot. (Lead guard and leads not shown for clarity)

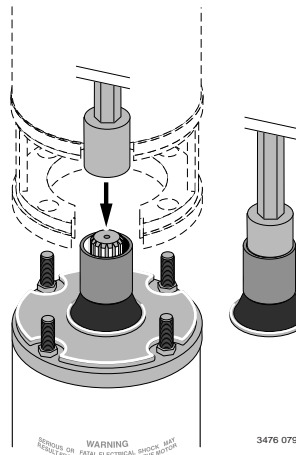

TROUBLESHOOTING GUIDE

PROBLEM	CHECK	CORRECTIVE ACTION
<p>Motor will not start but fuses do not blow No voltage</p>	<p>No voltage at fuse box. No voltage at pressure switch No voltage at control box. Cable or splices bad. Control box incorrectly wired.</p>	<p>Replace blown fuses. Replace faulty pressure switch. Rewire supply to control box. Consult licensed electrician or serviceman. Reconnect control box correctly (see wiring diagrams, Pages 8 through 12).</p>
<p>Fuses blow or overload protector trips when motor starts Wrong size fuse or wrong size time delay fuse. Wire size too small Starting capacitor defective or blown. Low or high voltage</p> <p>Cable leads not correctly connected to control box.</p> <p>Broken wire in control box. Pump or motor stuck or binding.</p>	<p>Check fuse size against chart, Page 4.</p> <p>Check wire size against chart, Page 5. Check control box to see if starting capacitor has blown out. Check that line voltage is within $\pm 10\%$ of nameplate rated voltage while motor is running. Check control box wiring diagram against incoming power hookup. Check drop cable color coding.</p> <p>Examine all connections and wiring in control box. Check for locked rotor in pump.</p>	<p>Install correct fuse or time delay fuse.</p> <p>Install correct size wire. Replace starting capacitor.</p> <p>If voltage variation is greater than $\pm 10\%$, call power company to adjust voltage.</p> <p>Reconnect leads to match wiring diagram in control box cover. Reconnect drop cable so cable color code matches motor lead color code. Disconnect power and repair or replace faulty wire. If necessary, pull pump (make all possible above ground checks first). If pump is locked, replace it. Clean well of all sand or lime before reinstalling pump.</p>
<p>Fuses blow or overload protector trips when motor is running Low or high voltage.</p> <p>High ambient (atmospheric temperature) Control box with wrong voltage or horsepower rating.</p> <p>Wire size too small Cable splices or motor leads grounded, shorted, or open.</p>	<p>Check that line voltage is within $\pm 10\%$ of rated nameplate voltage while motor is running. Check temperature of control box.</p> <p>Compare voltage and horsepower on motor nameplate with those given on control box nameplate or on circuit diagram inside control box cover. Check wire size against chart, Page 5. Consult licensed electrician or qualified serviceman.</p>	<p>If voltage variation is more than $\pm 10\%$, call power company to adjust voltage.</p> <p>Do not mount control box in direct sunlight.</p> <p>Replace control box if numbers do not match.</p> <p>Install correct wire size. Do not attempt to disassemble pump or motor.</p>
<p>Pump starts too frequently Leaks in system.</p> <p>Pressure switch.</p> <p>Tank waterlogged.</p> <p>Leak in drop pipe.</p> <p>Pressure switch too far from tank.</p>	<p>Check all tank connections with soapsuds for air leaks. Check plumbing for leaks.</p> <p>Check for defective switch or switch out of adjustment.</p> <p>Pre-charged tanks; check tank pre-charge air pressure, check for leak in bladder.</p> <p>Air over water tanks: check for air leaks. Check Air Volume Control (AVC). Check sniffer valve operation. Raise drop pipe one length at a time until water stands in pipe. Measure distance from pressure switch to tank.</p>	<p>System must be air and water tight.</p> <p>Re-adjust or replace pressure switch.</p> <p>Pre-charge tanks: adjust air pressure to 2 PSI (13.8 kPa) less than pump cut-in pressure (when there is no water pressure on system). Replace bladder if necessary. Air over water tanks: repair or replace tanks; replace sniffer valves if necessary.</p> <p>Replace pipe above that point.</p> <p>Move switch to within one foot of tank.</p>

TROUBLESHOOTING GUIDE (cont.)

PROBLEM	CHECK	CORRECTIVE ACTION
<p>Little or no water delivered</p> <p>Bleeder orifice check valve stuck or installed backwards (standard tank only).</p> <p>Low water level.</p> <p>Low voltage.</p> <p>Plugged intake screen.</p> <p>Check valve at pump discharge stuck.</p> <p>Worn impellers and diffusers.</p>	<p>Examine valve.</p> <p>Determine lowest water level in well while pump is running and compare to pump depth setting.</p> <p>Check voltage at control box with pump running. Check incoming wire size and drop cable size against chart, Page 5.</p> <p>Pull pump and check condition of screen.</p> <p>Pull pump and examine check valve.</p> <p>Make sure system is clear of obstructions and pump is in solid water and operation normally.</p>	<p>If stuck, free valve; if installed backwards, reverse it.</p> <p>Lower pump further into well (but at least 5' (1.6M) above bottom of well). Throttle pump discharge until discharge equals recovery rate of well. NOTICE: Running pump while airlocked can cause loss of prime and seriously damage pump.</p> <p>Install larger wire from meter to control box. Install larger wire from control box to pump. If necessary, have power company raise supply voltage.</p> <p>Clean or replace as necessary.</p> <p>Free check valve.</p> <p>Replace pump.</p>
<p>Air or milky water discharge from faucets</p> <p>Gas in well water.</p> <p>Air volume control not working (standard tanks only).</p>	<p>Check for presence of gas in well water.</p> <p>Make sure ports and ball check valves are clear.</p>	<p>Remove bleeder orifices; plug tees. Be sure plugged tees do not leak. If necessary, separate gas from air before it enters pressure tank.</p> <p>Replace control if necessary.</p>

LIMITED WARRANTY

Sta-Rite Industries, Inc., warrants to the original consumer of the products listed below, that they will be free from defects in material and workmanship for the Warranty Period from the date of original installation or manufacture as noted.

Product	Warranty Period
Water Systems Products – jet pumps, small centrifugal pumps, submersible pumps and related accessories	<i>whichever occurs first:</i> 1 year from date of original installation, or 2 years from date of manufacture
Hydro-Flow Filters	1 year from date of purchase
Signature 2000® Fibrewound Tanks	5 years from date of original installation
Pro-Source™ Steel Pressure Tanks	5 years from date of original installation
Pro-Source™ Epoxy-Lined Tanks	3 years from date of original installation
Sump/Sewage/Effluent Products	1 year from date of original installation, or 2 years from date of manufacture

Our warranty will not apply to any product that has been subject to negligence, misapplication, improper installation or maintenance. In the event a three phase submersible motor is operated with single phase power through a phase converter, or if three-leg ambient compensated, extra-quick trip overload relays of recommended size are not used, our warranty is void.

Buyer's only remedy and Sta-Rite Industries, Inc.'s only duty is to repair or replace defective products (at Sta-Rite Industries, Inc.'s choice). Buyer agrees to pay all labor and shipping charges associated with this warranty and to request warranty service through the installing dealer as soon as a problem is discovered. If warranty service is requested more than 30 days after the Warranty Period has ended, it will not be honored.

STA-RITE INDUSTRIES, INC. SHALL NOT BE LIABLE FOR ANY CONSEQUENTIAL, INCIDENTAL, OR CONTINGENT DAMAGES WHATSOEVER.

THE FOREGOING WARRANTIES ARE EXCLUSIVE AND IN LIEU OF ALL OTHER EXPRESS WARRANTIES. IMPLIED WARRANTIES, INCLUDING BUT NOT LIMITED TO THE IMPLIED WARRANTIES OF MERCHANTABILITY AND FITNESS FOR A PARTICULAR PURPOSE, SHALL NOT EXTEND BEYOND THE WARRANTY PERIOD PROVIDED HEREIN.

Certain states do not permit the exclusion or limitation of incidental or consequential damages or the placing of limitations on the duration of an implied warranty, therefore, the limitations or exclusions herein may not apply. This warranty sets forth specific legal rights and obligations, however, additional rights may exist, which may vary from state to state.

Supersedes all previous publications.

Sta-Rite Industries, Inc. 293 Wright St., Delavan, WI 53115

LEAD FREE PER ANSI/NSF61 STANDARDS

This product has undergone testing for lead by Underwriters Laboratories and has met or surpassed the ANSI/NSF61 standards for lead. This product also meets the Safe Drinking Water Act.

Signature 2000® Xtended Warranty Submersible/Tank Packages

Size the Sta-Rite Signature 2000® Fibrewound or Pro-SourcePlus™ Steel Pressure Tank with a 4" Signature 2000® pump per the chart below and receive a **FREE** Xtended 5-Year Warranty on the 4" Signature 2000® submersible pump.

Fill in the information from the tank and pump.

Signature 2000® 4" Submersibles, 2 and 3 Wire

1/2 thru 1-1/2 HP	Fibrewound Pressure Tanks						
	SR20	SR35	SR40	SR48	SR60	SR85	SR119
5 GPM Series	X	X	X				
7 GPM Series	X	X	X				
10 GPM Series		X	X	X			
15 GPM Series				X	X	X	
20 GPM Series					X	X	X
30 GPM Series						X	X
50 GPM Series						(2)	(2)

2 thru 5 HP	Fibrewound Pressure Tanks						
	SR20	SR35	SR40	SR48	SR60	SR85	SR119
5 GPM Series		X	X	X			
7 GPM Series			X	X	X	X	
10 GPM Series					X	X	
15 GPM Series						X	X
20 GPM Series						X	X
30 GPM Series							X
50 GPM Series						(2)	(2)

1/2 thru 1-1/2 HP	Pro-SourcePLUS™ Models						
	PSP42S	PSP42T	PSP75T	PSP82T	PSP120	PSP200	PSP220
5 GPM Series	X	X					
7 GPM Series	X	X					
10 GPM Series			X	X			
15 GPM Series					X	X	
20 GPM Series						X	X
30 GPM Series							X
50 GPM Series							(2)

2 thru 5 HP	Pro-SourcePLUS™ Models						
	PSP42S	PSP42T	PSP75T	PSP82T	PSP120	PSP200	PSP220
5 GPM Series				X			
7 GPM Series					X		
10 GPM Series						X	
15 GPM Series							X
20 GPM Series						(2)	(2)
30 GPM Series					(2)	(2)	(2)
50 GPM Series							(3)

(2) Tanks. (3) Tanks.

FIVE YEAR



Xtended PROTECTION PLAN
APPLICATION FORM

Signature 2000® 4" Submersible Pumps

1/2 HP - 5 HP

To the dealer: Complete the dealer portion of the Xtended Warranty application including the pump model, tank model, date codes and installation date. Present the application form to the homeowner for completion and forward to Sta-Rite Industries, Inc.

To the homeowner: Complete the homeowner portion of the Xtended Warranty and send the applicable payment along with a copy of your invoice (within 90 days of purchase) to:

Sta-Rite Industries Inc.
Attn: Warranty Administrator
P.O. Box 95389
Chicago, IL 60694-5389

Upon receipt of the application form and payment, Sta-Rite Industries, Inc. will issue an Xtended Warranty Certificate to the homeowner. This certificate must be retained and produced in the event of a failure within the 5 year warranty period. Sta-Rite Industries will also send a copy of the certificate to the installing dealer for notification.

Xtended Warranty pricing:	Model	Motor Size	Price
	Signature 2000®	1/2 HP - 1-1/2 HP	\$25.00
	Signature 2000®	2 HP - 5 HP	\$50.00

What the warranty covers: The 5 Year Xtended Warranty provides 4 years of additional warranty coverage, (standard warranty is 1 year) – should the submersible pump models listed above fail within 5 years from the original date of installation. If failure occurs, Sta-Rite Industries agrees to repair or replace at no charge the models identified on this application. This protection plan includes failure caused by abrasion, corrosion and lightning.

What the warranty does not cover: The Xtended Warranty Plan does not cover (1) labor charges to pull or reinstall your submersible pump; (2) failure attributed to cables, pipes, controls or accessories; (3) failure attributable to misuse or improper installation; (4) operation without sufficient water (running dry); or (5) consequential, incidental or contingent damage. This Xtended Warranty is not intended to replace insurance coverage which otherwise may be applicable or available.

*This is not an Xtended Warranty – actual **warranty certificate** will come directly from manufacturer after application is received.)*

FIVE YEAR

Extended PROTECTION PLAN
APPLICATION FORM

Signature 2000® 4" Submersible Pumps

1/2 HP - 5 HP

Application Form

(Detach and mail with payment)

Homeowner Name _____ Phone # _____

Mailing Address _____

City, State, Zip _____

Pump Address (if different) _____

Dealer Name _____ Phone # _____

Address _____

City, State, Zip _____

Tank: Model # _____ Date code: _____

Pump: Model # _____ Date code: _____

Motor: Model # _____ Serial # _____

Control Box: Model # _____ Date Installed _____

Signature (Homeowner): _____