

INSTRUCTION BULLETIN

MP PUMPS

This MP FLOMAX pump was tested under full pressure and at maximum suction before it was shipped. Every precaution has been taken to

insure you of a trouble-free product. It will give you many years of service with very little attention, if installed properly.

READ INSTRUCTION BULLETIN CAREFULLY

It is important that this Instruction Bulletin be read carefully to fully familiarize yourself with the pump assembly arrangement. The instructions contained herein pertain to installation and maintenance of the pump assembly only.

Check unit carefully to make certain that no parts are missing or have been broken in shipment.

Packed separately with each unit are instruction booklets, parts lists and performance data.

INSTALLATION

For optimum performance, place pump as close to liquid source as possible to reduce suction lift to a minimum. For best results, pump should be installed not more than 15 feet above the liquid supply. Set the unit on solid footing and as nearly level as possible.

Pipe or hose of the same size as flanges provided should be used. Reinforced rubber suction hose is recommended because it provides greater flexibility and prevents collapsing due to vacuum in the suction line when pump is in operation. Suction line should be as short as possible and have as few elbows or bends as possible to keep friction loss at a minimum. Use pipe dope on all connections and make certain that all fittings are tight, particularly on the suction line where an air leak can prevent priming or reduce pump capacity.

A good suction strainer should be used. Suction strainers are available from your MP Distributor. Refer to the accessory section of the GENERAL PUMP PRICE LIST for the correct part number.

OPERATION

The FLOMAX pump is a self-priming centrifugal pump and only requires priming prior to its initial

start. The pump will retain sufficient liquid for self-priming thereafter.

Provision for a priming plug can be made by using a close nipple and tee on the discharge opening. A pipe plug installed in the top opening of the tee is easily removed when necessary to prime pump. Prime pump by filling pump housing with liquid.

If pump fails to prime or stops pumping, check for the following possible causes:

1. No liquid in the pump housing.
2. Air leak in the suction line due to loose connections or pin holes in the hose.
3. Collapsed suction line or clogged strainer.
4. Seal worn and leaking air.
5. Worn impeller – too much clearance between impeller and wear plate.
6. Pump not running fast enough.
7. Suction lift is too high.
8. Trying to prime against too high a discharge head.

MAINTENANCE

The FLOMAX pump is of simple construction with only one moving part. The impeller on the FLOMAX 5 and 8 is threaded to a stainless steel drive sleeve. The impeller on the FLOMAX 10 and 15 has a stainless steel cover pressed on. The sleeve slips over the drive shaft and is locked to the drive shaft with a two-piece clamp. This means you use a standard drive shaft – no special tapers or threads. It's easy to adjust or remove the impeller.

FLOMAX pumps are available with either a self-lubricated shaft seal, or a grease lubricated shaft seal.

The self-lubricated seal is lubricated by the liquid in the pump. Operating the pump dry will seriously damage the seal.

To lubricate the grease lubricated seal, turn the wing nut on the grease cup to the left – counterclockwise.

If the pump is to be left standing idle for any length of time in freezing conditions, the pump housing should be drained. Draining is provided for by a drain plug located at the base of the pump housing.

DISASSEMBLY

Disconnect power (or spark plug wire) to prevent accidentally starting.

Disconnect lines and drain pump housing.

TO REMOVE PUMP HOUSING

Remove capscrews and nuts holding pump housing to mounting base (where used).

Remove nuts and lockwashers holding pump housing to the adapter.

Loosen the housing and remove carefully to prevent tearing gaskets.

TO REMOVE IMPELLER

If pump is equipped with a grease lubricated seal, relieve pressure in grease cup by turning wing handle to the right – clockwise.

Remove impeller clamp nuts and clamp to unlock impeller drive sleeve from drive shaft.

Use two “jimmy” bars or large screwdrivers diagonally across from each other between adapter and end of drive sleeve. Pry the sleeve off the drive shaft.

Before removing the seal from the impeller, inspect the carbon washer. If nicked or worn – replace it with a new one. Inspect the seal seat (still in the pump adapter). If no nicks, scratches or cracks appear and surface is clean and smooth, there is no need to replace it. If replacement is necessary, remove adapter by removing four hex nuts and washers. Place adapter on flat surface, with impeller side down. Press out seal seat by using wooden end of a screw driver or similar tool. (SEE PARAGRAPH REFERRING TO REASSEMBLY.)

TO REPLACE IMPELLER

On the two-piece impeller it is not necessary to remove the seal. Place impeller drive sleeve between two pieces of wood in a vise. Hold impeller sleeve carefully so you do not damage the seal assembly. Hold firmly and unthread impeller by turning counterclockwise – left hand. Replace with a new impeller. Be sure seal spring fits over hub on back of impeller.

TO REMOVE ADAPTER

Remove the four nuts and lockwashers. Loosen and remove adapter.

TO INSPECT SELF-LUBRICATED SEAL ASSEMBLY

After the impeller and drive sleeve have been removed from the drive shaft, inspect the lapped sealing face of carbon washer (Part 3) for wear which would necessitate replacement.

Inspect lapped sealing face of floating seat (Part 4) in adapter housing counterbore for scuffing or cracks. If necessary to replace, press out old seat and ring, and proceed as outlined in paragraph on MOUNTING ADAPTER.

If spring and/or bellows (Part 1 and 2) are damaged and require replacement, lubricate the impeller sleeve with a clean light oil and slide parts off sleeve.

TO INSPECT GREASE LUBRICATED SEAL ASSEMBLY (See Fig.1)

After the impeller assembly has been removed inspect the lapped sealing face of the steel washer (Part 3). Inspect the seal seat (Part 4) in the adapter casting. If either is scored, chipped or

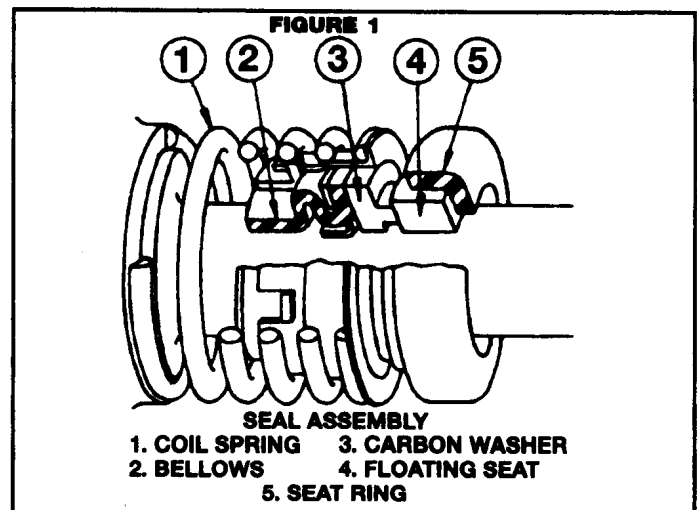

worn, the entire seal should be replaced. (See instruction under **MOUNTING GREASE LUBRICATED SEAL ASSEMBLY.**)

TO REMOVE WEAR PLATE

After pump housing has been removed from the adapter, inspect the wear plate. If wear plate is badly worn, it should be replaced. To remove wear plate, loosen and remove acorn nuts and gaskets on the outside of the pump housing.



CAUTION

When replacing wear plate, be sure to use new gaskets under acorn nuts to seal against air leaking in on suction side during priming cycle.

INSPECTION

After pump has been disassembled, check all parts over carefully for wear or damage. When ordering parts for your pump, be sure to specify model and serial numbers shown on name plate.

REASSEMBLY

MOUNTING ADAPTER

Before mounting adapter, clean counterbore with kerosene or similar cleanser.

Clean and lubricate with light oil the synthetic rubber member on seal seat and press (do not drive) the assembly into the adapter counterbore, seating it firmly and squarely.



CAUTION

In handling, avoid dropping seat and take particular care not to scratch the lapped face.

Install adapter. Install lockwashers and tighten four nuts evenly.

MOUNTING SELF-LUBRICATED SEAL ASSEMBLY (See Fig. 1)

Mount seat and seat ring (Part 4 and 5) as outlined above. Inspect impeller sleeve for nicks and burrs. Polish sleeve with fine emery or crocus cloth. Then clean and lubricate with a clean light oil.

Slip the coil spring (Part 1) onto the impeller sleeve making certain that it is seated properly on

the shoulder of the impeller.

Lubricate the inside of the washer and bellows assembly (Part 2 and 3) with a clean light oil and slide it onto the impeller drive sleeve only until it clears the chamfer.

Slide the seal bellows and washer assembly onto the impeller drive sleeve. Push the seal down over the drive sleeve with even pressure. Pull the seal head back up to the position where there is no spring load. This insures proper assembly on the drive sleeve.

Before sliding the impeller onto the drive shaft, wipe the lapped sealing faces of the floating seat (Part 4) in the adapter counterbore and the carbon washer (Part 3) on the bellows assembly perfectly clean. Then lubricate both faces with a clean light oil.

IMPORTANT

The assembly of impeller and seal to the drive shaft should take place as soon as the bellows assembly is slipped on the impeller sleeve so as to avoid bonding of the bellows to the sleeve at improper working height.



CAUTION

Foreign matter between sealing faces will cause leakage and shorten the life of the seal.

MOUNTING GREASE LUBRICATED SEAL ASSEMBLY

Lubricate the two "O" rings on the seal seat (Part 5).

Press the seal seat into the adapter firmly and squarely. Be sure the two grease holes in the seal seat are turned 90° from the grease hole in the adapter casting. (See Fig. 2).

Use a square piece of soft wood, or the end of a hammer handle to press (do not drive) seal seat in firmly and squarely.



CAUTION

Do not tear the "O" rings on the seal seat.

Turn the adapter casting upside down to observe the fit of the seal seat. Seal seat should bottom. Install the adapter. Tighten four nuts and lockwashers on the studs.

**FIGURE 2
INSTALLATION OF SEAL SEAT
FOR GREASE SEAL ASSEMBLY**

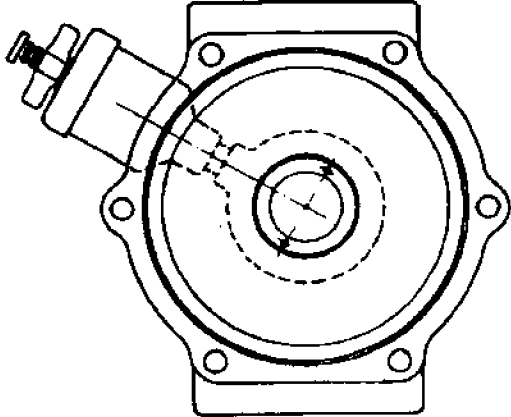

WHEN INSTALLING SEAL SEAT IN PUMP ADAPTER, THE TWO HOLES IN SEAT FACE SHOULD BE AT RIGHT ANGLES TO CENTERLINE OF GREASE FITTING AS SHOWN

Turn the grease cup handle slowly to the left (counterclockwise) until you see that grease is being forced through the two lubricating holes in the seal seat.

This purges the grease cavity of air and insures proper lubrication.

To replace the seal spring, bellows and washer assembly on the impeller sleeve: clean and lubricate the impeller sleeve with light oil, lubricate the inside of the seal bellows (rubber member) with light oil.

Slide the seal bellows, spring and washer assembly onto the impeller sleeve making certain that it seats properly on the shoulder of the impeller. Push the seal down over the drive sleeve with even pressure. Pull the seal head back up to the position where there is no spring load. This insures proper assembly on the sleeve.

MOUNTING SEVERE-SERVICE SEAL ASSEMBLY

The MP PUMPS Severe-Service Seal is a precision assembly requiring care in installation. To insure proper operation it is necessary to install this seal as follows:

1. Thoroughly clean the seal seat cavity in the pump adapter.
2. Lubricate the seal seat O-Ring with light oil and carefully install the seal into the seal cavity that is inside the adapter.

IMPORTANT

The assembly of impeller and seal to drive shaft should take place as soon as the bellows assembly is slipped onto the impeller sleeve so as to avoid bonding of the bellows to the sleeve at improper working height.

MOUNTING IMPELLER

Do not use drive key between drive shaft and impeller sleeve. The clamp will drive the sleeve. Slide the impeller sleeve onto the drive shaft. Replace impeller clamp and capscrews, lockwashers and nuts.

Before tightening clamp adjust clearance between back face of impeller and adapter allowing from .015" to .020" clearance. Tighten impeller clamp to lock impeller onto drive shaft. This automatically sets face clearance of impeller when housing is mounted.

MOUNTING PUMP HOUSING

Replace gaskets on pump housing and mount housing on the adapter. Replace two lockwashers and nuts on studs diagonally across from each other and tighten. Turn drive shaft over slowly by hand and listen at outlet opening on housing for any rubbing of impeller on the housing or wear plate.

The clearance between the impeller and wear plate can be checked with a feeler gauge. Normal clearance is .015" to .025". If clearance exceeds .025 readjust impeller. If the impeller rubs use an additional gasket to space impeller.

After clearance has been established, replace lockwashers and nuts on remaining studs and tighten. If capscrews and nuts are used to hold housing to mounting base, replace these and tighten.

3. Using a soft clean cloth, clean and lubricate both seal faces with light oil.

NOTE: Any foreign matter between seal faces will cause leakage and shorten seal life.

4. Complete assembly of seal and pump – see above.
5. Rotate by hand before start up.



MP PUMPS, INC.

34800 BENNETT • FRASER, MI 48026-1686
(586) 293-8240 • FAX (586) 293-8469
(800) 563-8006 • www.mppumps.com

FORM 3001-F
PRINTED IN U.S.A. (01/03)