

Please read and save this Repair Parts Manual. Read this manual and the General Operating Instructions carefully before attempting to assemble, install, operate or maintain the product described. Protect yourself and others by observing all safety information. The Safety Instructions are contained in the General Operating Instructions. Failure to comply with the safety instructions accompanying this product could result in personal injury and/or property damage! Retain instructions for future reference.

# Centrifugal Pumps

## Stainless Steel Models

Refer to form 1808-634-00 for General Operating and Safety Instructions.

### Description

These non self-priming centrifugal pumps are intended for liquid transfer, heating and cooling circulation, booster service and other industrial applications where no suction lift is required.

All models feature 316 stainless steel construction, a semi-open clog-resistant impeller, and a 3450 RPM motor. A dual volute casing is used on all models except 4240-98. A mechanical seal (comprised of carbon, ceramic, Viton elastomer, and stainless steel components) isolates motor from liquid being pumped. Discharge port on pump casing can be rotated in 90° increments, with vent and drain plugs for all positions. Pumps handle liquids from 40° to 200° F (4° to 93° C) or 40° to 180° F (4° to 82° C) with optional Buna N seals. Maximum ambient temperature 104° F (40° C). Casing working pressure to 100 psi (689 kPa). These are manual units, no controls are supplied. For use with nonflammable, non-abrasive liquids, compatible with pump component materials.

### Specifications

Model	DRIVER		NEMA Frame	Power Supply @60 Hz	PUMP Port Size (Inches)*	Weight (Lbs.)
	HP	Enclosure				
3150-98	2	TEFC	145JM	230/460 VAC, 3-phase	2 x 1½	53
3151-98	3	TEFC	182JM	230/460 VAC, 3phase	2 x 1½	69
3152-98	5	TEFC	184JM	230/460 VAC, 3-phase	2 x 1½	90
3156-98	2	TEFC	56J	115/230 VAC, 1-phase	2 x 1½	65
3157-98	2	TEFC	56J	230/460 VAC, 3-phase	2 x 1½	64
3158-98	2	ODP	56J	115/230 VAC, 1-phase	2 x 1½	62
3159-98	2	ODP	56J	230/460 VAC, 3-phase	2 x 1½	61
315A-98	3	TEFC	56J	230 VAC, 1-phase	2 x 1½	71
315B-98	3	TEFC	56J	230/460 VAC, 3-phase	2 x 1½	74
315C-98	3	ODP	56J	230 VAC, 1-phase	2 x 1½	72
315D-98	3	ODP	56J	230/460 VAC, 3-phase	2 x 1½	71
315E-98	3	TEFC	184JM	230 VAC, 1-phase	2 x 1½	121
4240-98	7½	TEFC	184JM	230/460 VAC, 3-phase	2 x 1½	105
4250-98	10	TEFC	184JM	230/460 VAC, 3-phase	3 x 2	117
4251-98	15	TEFC	215JM	230/460 VAC, 3-phase	3 x 2	180
4260-98	7½	TEFC	184JM	230/460 VAC, 3-phase	3 x 3	104
4261-98	10	TEFC	184JM	230/460 VAC, 3-phase	3 x 3	110

NOTE: Driver data is subject to change without notice, see label on driver for actual specifications.

(\*) Standard NPT (female) pipe thread.

(ODP) Open Drip Proof

(TEFC) Totally Enclosed Fan Cooled

# Centrifugal Pumps

## Stainless Steel Models

### Performance Chart

Model	GPM of Water at Total Head in Feet											Max. Head†
	10'	20'	30'	40'	50'	60'	70'	80'	90'	100'	110'	
315 (2HP)	170 gpm	150	130	100	65	25	–	–	–	–	–	62 ft.
NPSHR‡	23 ft.	20	18	15	14	14	*	*	*	*	*	
315 (3HP)	–	–	165	145	125	95	60	15	–	–	–	82
NPSHR‡	*	*	22	20	18	15	14	14	*	*	*	
315 (5HP)	–	–	–	–	200	185	165	145	120	90	50	115
NPSHR‡	*	*	*	*	25	25	23	20	17	15	14	
426 (7½HP)	–	–	–	425	385	340	285	200	75	–	–	94
NPSHR‡	*	*	*	23	19	15	12	10	7	*	*	
426 (10HP)	–	–	–	500	450	395	340	270	165	–	–	98
NPSHR‡	*	*	*	25	25	19	15	12	9	*	*	

Model	GPM of Water at Total Head in Feet											Max. Head†
	80'	90'	100'	110'	120'	130'	140'	150'	160'	170'	180'	
424 (7½HP)	178 gpm	170	158	145	130	110	92	70	40	0	–	170 ft.
NPSHR‡	19 ft.	18	17	15	13	11	9	*	*	*	*	
425 (10HP)	333	300	280	250	210	170	100	–	–	–	–	145
NPSHR‡	16	14	12	10	7	4	*	*	*	*	*	
425 (15HP)	385	365	345	325	305	280	255	225	196	160	115	194
NPSHR‡	22	20	18	16	14	12	10	8	6	4	*	

(\*) Operation of pumps beyond range indicated will result in reduced pump life, pump damage and/or motor damage.

(†) Shut-off; to convert psi, multiply by specific gravity and divide by 2.31.

(‡) NPSHR: Net Positive Suction Head Required by pump in feet of water at GPM indicated, under flooded suction conditions.

Insufficient NPSH can cause pump cavitation, resulting in a noisy pump and reduced pump life.

### Installation

Check Performance Chart for recommended NPSHR. Problems will arise in operation of this pump unless recommended NPSHR is supplied to pump (see "Troubleshooting").

### Maintenance

**⚠ WARNING** *Make certain that unit is disconnected from power source before attempting to service or remove any component.*

#### REMOVAL OF OLD SEAL

Refer to Figure 2 and 3.

**IMPORTANT:** Always replace both seal seat (Ref. No. 9) and seal head (Ref. No. 10) to insure proper mating of components! Also, impeller seal (Ref. No. 16) (where applicable) should be

replaced anytime impeller fastener (Ref. No. 13) has been removed.

1. Remove four fastener and washers (Ref. Nos. 6 & 7) that connect casing (Ref. No. 14) to adapter (Ref. No. 3).
2. Remove casing and casing seal (Ref. No. 8).
3. Remove impeller fastener, impeller seal (where applicable), and impeller (Ref. No. 12).

**IMPORTANT:** Care should be taken to insure that same number of shim washers (Ref. No. 11) are replaced behind impeller as were removed. These shim washers are located directly

behind impeller.

4. Seal head and shaft sleeve (Ref. No. 17) (where applicable) can now be pulled from shaft.
5. Pry seal seat from casing cover/adapter.
6. Push seal head from shaft sleeve (where applicable).

#### INSTALLATION OF NEW SEAL

**⚠ CAUTION** *The precision lapped faces on mechanical seal are easily damaged. Handle replacement seal carefully.*

1. Thoroughly clean all surfaces of seal seat cavity.
2. Using a clean cloth, wipe shaft and shaft sleeve (where applicable) and make certain that they are perfectly clean.

# Models 3150-98 thru 315E-98 and 4240-98 thru 4261-98

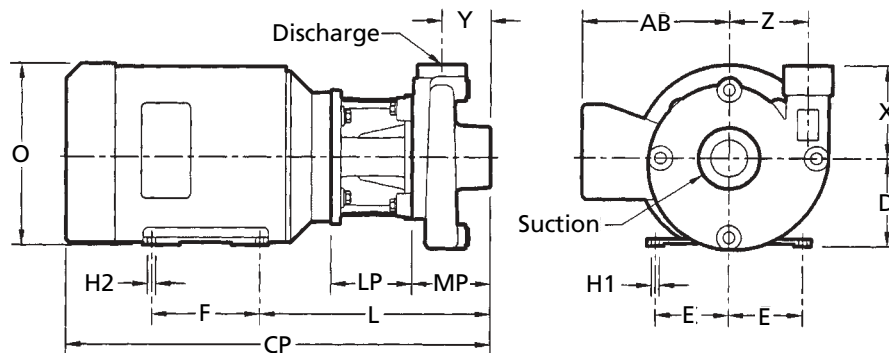

Figure 1 - Dimensions

## Dimensions (Inches)

Model	SUC*	DIS*	AB†	CP†	D	E	F	H1
3150-98	2	1½	6.13	17.57	3.50	2.75	5.00	0.34
3151-98	2	1½	7.50	21.63	4.50	3.75	4.50	0.41
3152-98	2	1½	7.50	21.63	4.50	3.75	5.50	0.41
3156-98	2	1½	4.56	17.70	3.50	2.44	3.00	0.88
3157-98	2	1½	4.90	16.60	3.50	2.44	3.00	0.88
3158-98	2	1½	—	17.20	3.50	2.44	3.00	0.88
3159-98	2	1½	—	16.30	3.50	2.44	3.00	0.88
315A-98	2	1½	4.90	18.60	3.50	2.44	3.00	0.88
315B-98	2	1½	4.90	18.10	3.50	2.44	3.00	0.88
315C-98	2	1½	—	17.40	3.50	2.44	3.00	0.88
315D-98	2	1½	—	17.20	3.50	2.44	3.00	0.88
315E-98	2	1½	8.63	24.16	3.50	2.44	3.00	0.88
4240-98	2	1½	7.50	21.38	4.50	3.75	5.50	0.41
4250-98	3	2	7.50	21.53	4.50	3.75	5.50	0.41
4251-98	3	2	8.25	26.03	5.25	4.25	7.00	0.44
4260-98	3	3	7.50	22.38	4.50	3.75	5.50	0.41
4261-98	3	3	7.50	22.38	4.50	3.75	5.50	0.41

Model	H2	L	LP	MP	O†	X	Y	Z
3150-98	0.34	10.38	4.13	4.00	7.14	4.75	2.50	4.00
3151-98	0.41	12.69	4.13	4.00	9.28	4.75	2.50	4.00
3152-98	0.41	11.76	4.13	4.00	9.28	4.75	2.50	4.00
3156-98	0.34	8.59	2.03	4.00	8.70	4.75	2.50	4.00
3157-98	0.34	8.59	2.03	4.00	7.10	4.75	2.50	4.00
3158-98	0.34	8.59	2.03	4.00	8.10	4.75	2.50	4.00
3159-98	0.34	8.59	2.03	4.00	6.60	4.75	2.50	4.00
315A-98	0.34	8.59	2.03	4.00	8.80	4.75	2.50	4.00
315B-98	0.34	8.59	2.03	4.00	7.10	4.75	2.50	4.00
315C-98	0.34	8.59	2.03	4.00	8.10	4.75	2.50	4.00
315D-98	0.34	8.59	2.03	4.00	6.60	4.75	2.50	4.00
315E-98	0.34	8.59	2.03	4.00	9.28	4.75	2.50	4.00
4240-98	0.41	11.51	3.50	4.38	9.28	5.88	2.44	3.84
4250-98	0.41	11.66	3.50	4.53	9.28	5.00	2.78	4.75
4251-98	0.44	12.53	3.50	4.53	10.88	5.00	2.78	4.75
4260-98	0.41	12.51	4.13	4.75	9.28	6.50	2.75	4.50
4261-98	0.41	12.51	4.13	4.75	9.28	6.50	2.75	4.50

**NOTE:** All dimensions have a tolerance of  $\pm 1/8"$ .

(\*) Standard NPT (Female) Pipe Thread.

(†) This dimension may vary due to motor manufacturer's specifications.

**For Repair Parts, contact dealer where pump was purchased.**

Please provide following information:

- Model number
- Serial number (if any)
- Part description and number as shown in parts list

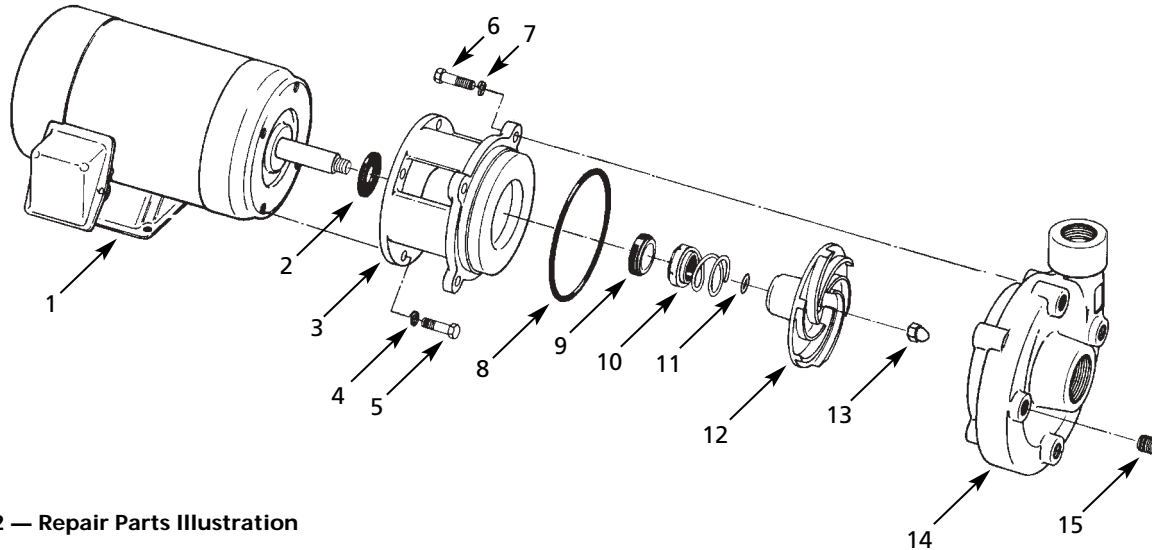

Figure 2 — Repair Parts Illustration

**Repair Parts List**

Ref. No.	Description	Part Number For Models:		Qty.
		3158-98 (2HP) 3159-98 (2HP) 3156-98 (2HP) 3157-98 (2HP)	315C-98 (3HP) 315D-98 (3HP) 315A-98 (3HP) 315B-98 (3HP)	
1	Motor -1 Phase ODP -3 Phase ODP -1 Phase TEFC -3 Phase TEFC	◆ 1626-024-00 ◆ 1626-025-00 ◆ 1626-070-00 ◆ 1626-054-00	◆ 1626-026-00 ◆ 1626-027-00 ◆ 1626-071-00 ◆ 1626-072-00	1
2	Slinger washer	1534-000-00	1534-000-00	1
3	Adapter	4890-031-01	4890-031-01	1
4	Washer	*	*	4
5	Fastener	*	*	4
6	Fastener	*	*	4
7	Washer	*	*	4
8	Casing seal -Viton	*	*	1
9, 10 †	Shaft seal assembly -Viton	1640-161-97	1640-161-97	1
11	Impeller shim set, includes (1) 0.005", (1) 0.020", (1) 0.030"	1806-044-90	1806-044-90	1
12	Impeller	3156-010-01	3156-010-02	1
13	Impeller fastener	1784-001-00	1784-001-00	1
14	Casing	3150-003-09	3150-003-09	1
15	Pipe plug	*	*	4
	Δ ‡ Seal kit -Viton (standard)	3156-300-91	3156-300-91	1
	Δ ‡ Seal kit -Viton & silicon carbide (optional)	3156-300-92	3156-300-92	1
	Δ ‡ Seal kit -Buna N & silicon carbide (optional)	3156-300-93	3156-300-93	1

- (Δ) Not shown.
- (\*) Standard hardware item, available locally.
- (‡) Includes all required seals, Ref. Nos. 8, 9, 10.
- (†) Seal head and seat available as set only.
- (◆) Requires foot 1626-040-90.

**For Repair Parts, contact dealer where pump was purchased.**

Please provide following information:

- Model number
- Serial number (if any)
- Part description and number as shown in parts list

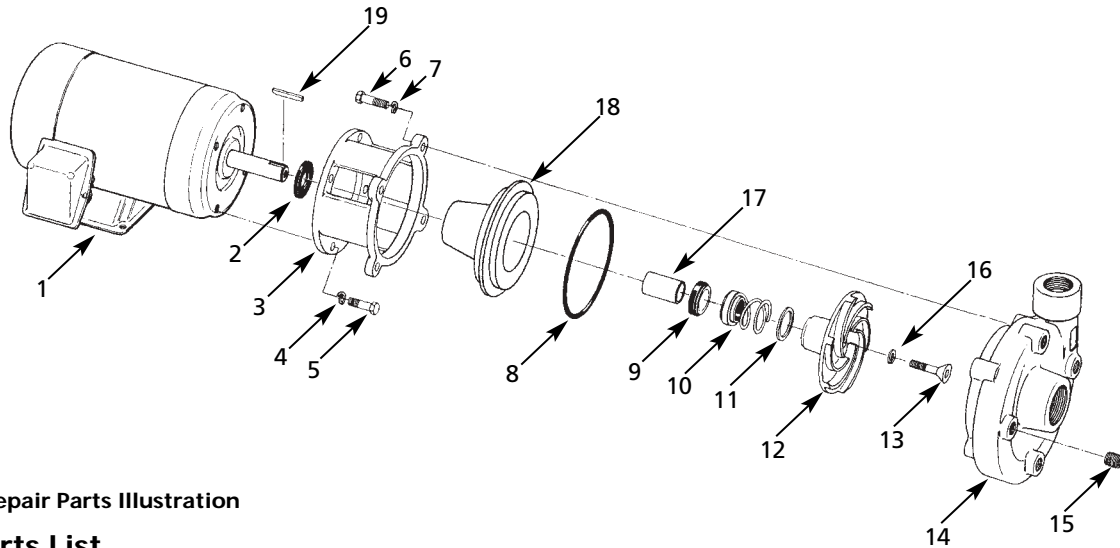

Figure 3 — Repair Parts Illustration

**Repair Parts List**

Ref. No.	Description	Part Number For Models:				Qty.
		3150-98 (2HP) 3151-98 (3HP) 3152-98 (5HP) 315E-98 (5HP)	4260-98 (7½HP) 4261-98 (10HP)	4240-98 (7½HP)	4250-98 (10HP) 4251-98 (15HP)	
1	Motor -3 Phase -3 Phase -3 Phase -1 Phase	1626-042-00 (2HP) 1626-043-00 (3HP) 1626-044-00 (5HP) 1626-078-00 (5HP)	1626-045-00 (7½HP) 1626-046-00 (10HP)	1626-045-00 (7½HP)	1626-046-00 (10HP) 1626-047-00 (15HP)	1
2	Slinger washer	1470-093-00	1470-093-00	1470-093-00	1470-093-00	1
3	Adapter	3150-033-09	3150-033-09	4252-033-01	4252-033-01	1
4	Washer	*	*	*	*	4
5	Fastener	*	*	*	*	4
6	Fastener	*	*	*	*	4
7	Washer	*	*	*	*	4
8	Casing seal -Viton	*	*	*	*	1
9, 10	† Shaft seal assembly -Viton	1640-163-91	1640-163-91	1640-163-91	1640-163-91	1
11	Impeller shim set, includes (1) 0.005", (1) 0.010", (1) 0.020"	1664-000-90	1664-000-90	1664-000-90	1664-000-90	1
12	Impeller	3150-013-09 (2HP) 3151-013-09 (3HP) 3152-013-09 (5HP)	4260-013-01 (7½HP) 4261-013-01 (10HP)	4240-013-01 (7½HP)	4250-013-01 (10HP) 4251-013-01 (15HP)	1
13	Impeller fastener	1759-003-00	1761-002-00	1759-003-00	1759-003-00 (10HP) 1757-005-00 (15HP)	1
14	Casing	3150-003-09	4260-003-01	4240-003-01	4250-003-01	1
15	Pipe plug	*	*	*	*	4
16	Impeller seal -Viton	*	*	*	*	1
17	Shaft sleeve	1472-000-00	1472-000-00	1472-000-00	1472-000-00	1
18	Casing cover	3150-023-09	3150-023-09	4240-023-01	4240-023-01	1
19	Key	1471-030-00	1471-030-00	1471-030-00	1471-030-00	1
Δ	‡ Seal kit -Viton (standard)	3150-300-91	3150-300-91	4240-300-91	4240-300-91	1
Δ	‡ Seal kit -Viton & silicon carbide (optional)	3150-300-92	3150-300-92	4240-300-92	4240-300-92	1
Δ	‡ Seal kit -Buna N & silicon carbide (optional)	3150-300-93	3150-300-93	4240-300-93	4240-300-93	1

(Δ) Not shown; (\*) Standard hardware item, available locally; (‡) Includes all required seals Ref. Nos. 8, 9, 10, 16; (†) Seal head and seat available as set only. When replacing a shaft seal assembly, a new impeller seal (Ref. No. 16) should also be used.

# Centrifugal Pumps

## Stainless Steel Models

### Maintenance (Continued)

3. Wet the rubber portion of new seal seat with a light coating of soapy water. While wearing clean gloves or using a clean light rag, press seal seat squarely into recess. Avoid scratching polished surface. If seat will not position properly, place a cardboard washer over polished surface and use a piece of pipe to press in, firmly but gently.
4. Dispose of cardboard washer. Check again to see that polished surface is free of dirt and all other foreign particles and that it is has not been scratched or damaged.
5. Wet the inside rubber portion of new seal head with a light coating of soapy water. Slide head onto shaft/shaft sleeve. Slide shaft sleeve with seal head onto motor shaft (where applicable). Seal head and seal seat will meet. Reinstall any shims which have been removed. (See "Shim Adjustment" section.)

6. Replace impeller key (where applicable), and impeller. Replace impeller seal (where applicable) before screwing impeller fastener into place.
7. Reassemble pump.
8. A short "run-in" period may be necessary to provide completely leak free seal operation.

### SHIM ADJUSTMENT

When installing a replacement impeller (Ref. No. 12) or motor (Ref. No. 1), it may be necessary to adjust number of shims (Ref. No. 11) to insure proper running clearance between impeller and casing (Ref. No. 14). Proceed as follows:

**NOTE:** A proper running clearance is less than 0.020".

1. For impeller replacement, add one 0.020" shim in addition to those removed originally.
2. For motor replacement, add two 0.020" shims in addition to shims removed during disassembly.

3. Reassemble pump as described in Steps 6 and 7. (See "Installation of New Seal" section.)

**IMPORTANT:** Insure that casing is snugly in place and check shaft to make sure it is turning freely (rotate impeller by using impeller fastener, Ref. No. 13, and a wrench). If it turns freely, check to insure that adapter (Ref. No. 3), casing cover (Ref. No. 18) (where applicable), and casing are fitted "metal to metal" where they meet on the outside. If they are not "metal to metal", tighten fasteners (Ref. No. 6) and recheck shaft for free turning. Tighten carefully, turning shaft while tightening so that motor bearings are not damaged in the event that too many shims were installed. If shaft seizes before fasteners are completely tight, disassemble pump and remove one shim and repeat reassembly.



