

Close-Coupled FCE 1/2 - 2 hp

BOOK: CCF-005
DATE: Jan. 1, 2012

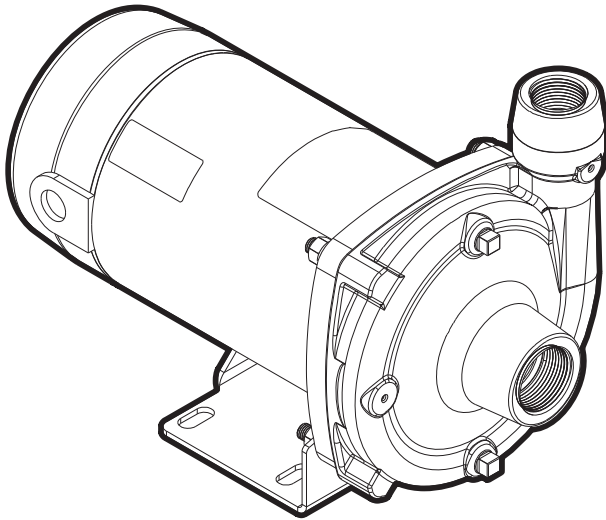

Specifications:

Capacities: to 85 gpm

Heads: to 125 feet

Working Pressure: 75 psi max

Temperature: 160 °F max

Rotation: clockwise viewed from motor end

Pipe Connections: NPT

HP	Discharge	Suction
1/2 - 1-1/2	1"	1-1/4"
2	1-1/4"	1-1/2"

Features:

- **Volute:** Cast iron, can be rotated for ease of installation. Tapped openings provided for draining.
- **Impeller:** Enclosed design for high efficiency. Glass filled Noryl®, with stainless hub.
- **Seal:** Standard carbon/ceramic faces, BUNA elastomers and 300 series stainless components.
- **Motor:** 3600 rpm, 56-Z square flange, open-drip-proof. Designed for continuous operation.
- **Mounting:** Can be mounted in vertical or horizontal position.

Applications:

- Water Circulation
- Booster Service
- Liquid Transfer
- Spraying Systems
- Jockey Pump
- General Service

Close-Coupled FCE 1/2 - 2 hp

Dimensional Drawings:

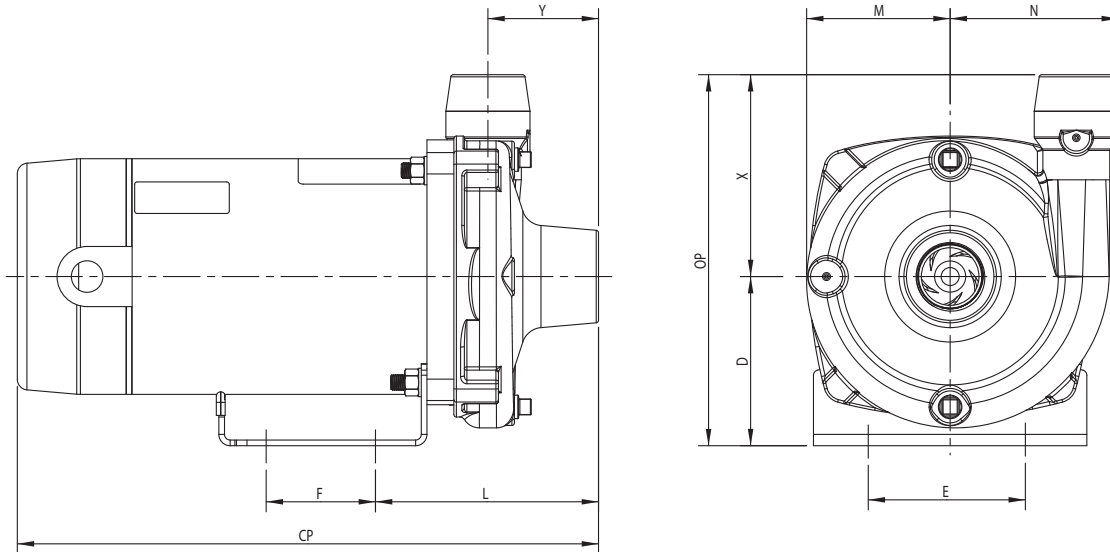

Dimensions:

HP	Disch. (NPT)	Suct. (NPT)	CP	D	E	F	L	M	N	OP	X	Y
1/2	1	1-1/4	13.75	4.00	4.88	3.00	5.53	3.69	4.00	8.90	4.90	2.63
3/4	1	1-1/4	14.07	4.00	4.88	3.00	5.53	3.69	4.00	8.90	4.90	2.63
1	1	1-1/4	15.57	4.00	4.88	3.00	5.53	3.69	4.00	8.90	4.90	2.63
1-1/2	1	1-1/4	15.90	4.00	4.88	3.00	5.53	3.69	4.00	8.90	4.90	2.63
2	1-1/4	1-1/2	15.82	4.46	4.88	3.00	5.88	4.12	4.72	10.78	6.31	2.88

Note: Dimensions are for estimating purposes only. All dimensions in inches.

Ordering Information:

Close-Coupled FCE 1/2 - 2 HP					
Pump Size (Dis x Suc - Imp)	HP	Voltage	Model Description	Order Number	Weight
1 x 1-1/4	1/2	115/230	FCE05CI	90200005	31
	3/4	115/230	FCE07CI	90200007	32
	1	115/230	FCE1C1	90200010	37
	1-1/2	115/230	FCE15CI	90200015	42
1-1/4 x 1-1/2	2	230	FCE2CI	90200020	46

Notes: All dimensions in inches. All weight in pounds.

Close-Coupled FCE 1/2 - 2 hp

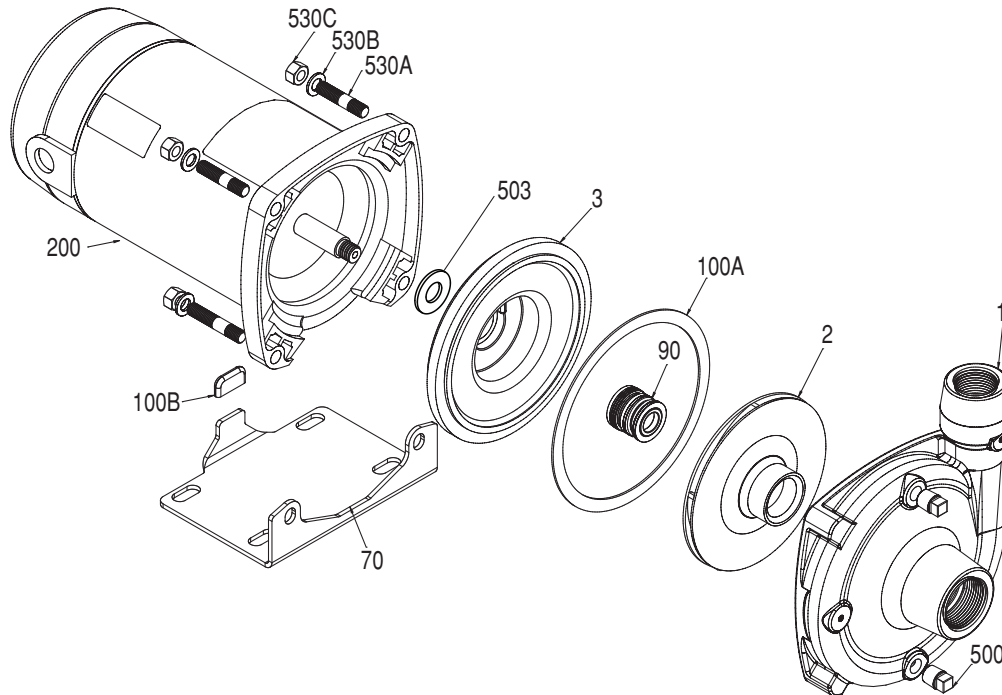

Materials and Parts:

Figure No.	Description	Repair No.					Materials of Construction
		S50	S75	S100	S150	S200	
1, 100A, 530A, 530B, 530C, 500	Casing Kit	305446922				305446923	Cast Iron, ASTM-A48 CL30; EPDM; Zinc Plated Steel; Cad-Plated Steel
2, 90, 100A, 503, 530B, 530C	Overhaul Kit	305446924	305446925	305446926	305446927	305446928	Carbon/Ceramic/Buna-SS; Noryl; EPDM; Zinc Plated Steel, Neoprene
3, 100A, 530B, 530C	Seal Plate Kit	305446929				305446930	Cast Iron, ASTM-A48 CL30; EPDM; Zinc Plated Steel
503, 530A, 530B, 530C	Fastener Kit	305446931				305446931	Zinc Plated Steel, Neoprene

Close-Coupled FCE 1/2 - 2 hp

Performance Curve:

3600 rpm
Nominal

