



## **TURFBOSS**

The Turf Boss from Franklin Electric is designed for residential or light commercial installations where it is necessary to maximize the volume of water being delivered while maintaining the ability to lift water from a source up to 25 feet below the pump.

### **Suitable for:**

- Agricultural Irrigation
- Lawn Sprinkling
- Industrial Dewatering
- HVAC Systems (Heat Pump and Air Conditioning)
- Water Transfer and Supply
- Freshwater Pumping
- Commercial/Industrial Liquid Transfer

# **FPS**



**Franklin Electric**

## Turf Boss

The Turf Boss excels when used to supply water to a timer operated irrigation system, but the rugged, easily serviced pump can be used in other areas as well. Some of which are residential water transfer, commercial dewatering, rainwater drainage, light agricultural irrigation, sump drainage, and industrial liquid transfer. As a premium self-priming sprinkler pump the Turf Boss is approved for indoor or outdoor operation through CSA and UL.

Whether it is a sprinkler system, a construction site, or a water transfer tank, when moving high volumes of water the Turf Boss guarantees the right amount of water right on time.

### Features:

- Self-priming design, with the ability to lift water from a depth of 25'
- Easily serviced through a back pull-out design, which leaves the all plumbing and both the pump's base and case undisturbed in their original location
- Rugged pump case constructed with heavy-duty cast iron ensures optimum durability, quiet operation, and long life
- Hydraulic components molded with Noryl®\* thermoplastic, when coupled with the floating stainless steel impeller eye-seal, ensures dependable and efficient operation
- Available with a 304 stainless steel impeller for maximum durability
- Industry proven indoor and outdoor 56C motors from A.O. Smith
- Single-phase: 1 and 1.5 hp motors are dual voltage, set to run with either 115 or 230 V incoming power (2 hp is 230 V only)
- Available in all horsepowers with a three-phase A.O. Smith Motor
- Mechanical shaft seal allows positive protection against leaking
- Built-in drain plug for easy winterizing and servicing
- Shut-off pressures up to 130 feet, and flow rates to 70 gpm
- Handles water temperatures up to 120 °F
- Integral 1" NPT priming plug
- 1.5" FNPT suction, 1.5" FNPT discharge

\* Noryl® is a registered trademark of G.E.

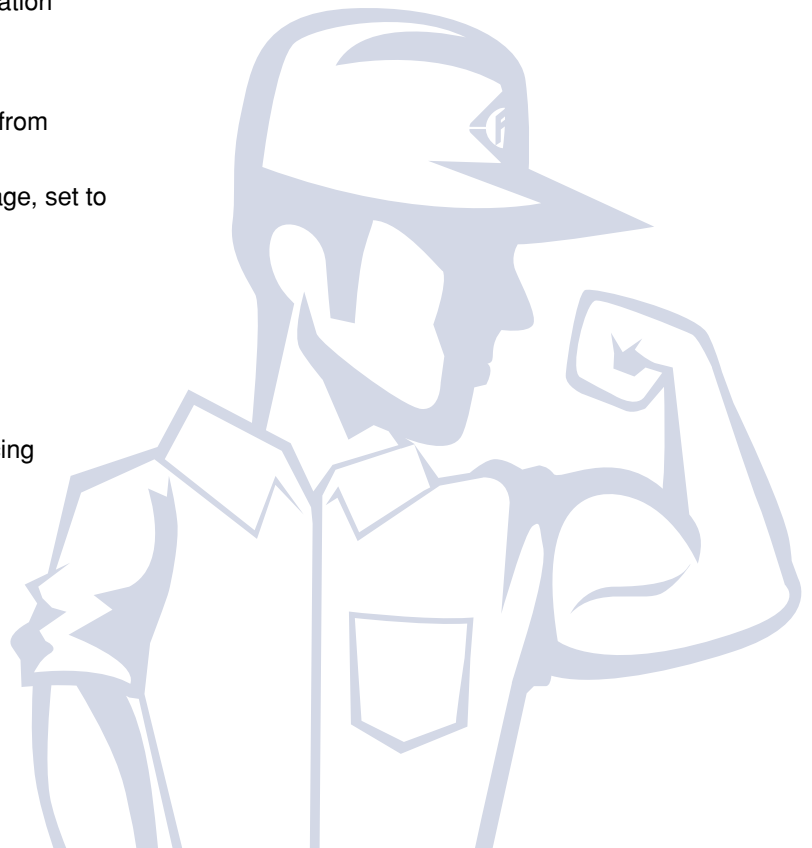

# Sprinkler Pumps

Turf Boss

FPS

## Ordering Information

Model No.	HP	Phase	Suction/Discharge	Voltage	Pump Unit	
					Order No.	Wt.
FTB1CI	1	1	1.5" x 1.5"	115/230	92980010	50
FTB15CI	1.5	1	1.5" x 1.5"	115/230	92980015	57
FTB2CI	2	1	1.5" x 1.5"	230	92980020	58
FTB1CI-SSI	1	1	1.5" x 1.5"	115/230	92981010	52
FTB15CI-SSI	1.5	1	1.5" x 1.5"	115/230	92981015	59
FTB2CI-SSI	2	1	1.5" x 1.5"	230	92981020	60
FTB1CI-SSI-T	1	3	1.5" x 1.5"	208-230/460	92983010	51
FTB15CI-SSI-T	1.5	3	1.5" x 1.5"	208-230/460	92983015	55
FTB2CI-SSI-T	2	3	1.5" x 1.5"	208-230/460	92983020	57
FTB1CI-PE	1	-	1.5" x 1.5"	-	92940010	28
FTB15CI-PE	1.5	-	1.5" x 1.5"	-	92940015	28
FTB2CI-PE	2	-	1.5" x 1.5"	-	92940020	28
FTB1CI-SSI-PE	1	-	1.5" x 1.5"	-	92941010	30
FTB15CI-SSI-PE	1.5	-	1.5" x 1.5"	-	92941015	30
FTB2CI-SSI-PE	2	-	1.5" x 1.5"	-	92941020	30

## Dimensions

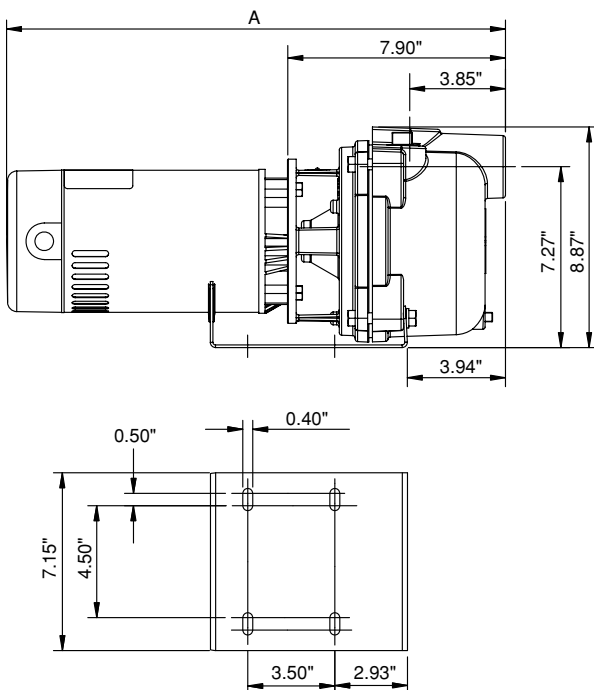

1.5" NPT Suction 1.5" NPT Discharge

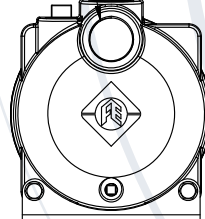

HP	Single-Phase (A)	Three-Phase (A)
1	20.0"	23.4"
1.5	21.6"	25.0"
2	21.6"	25.0"

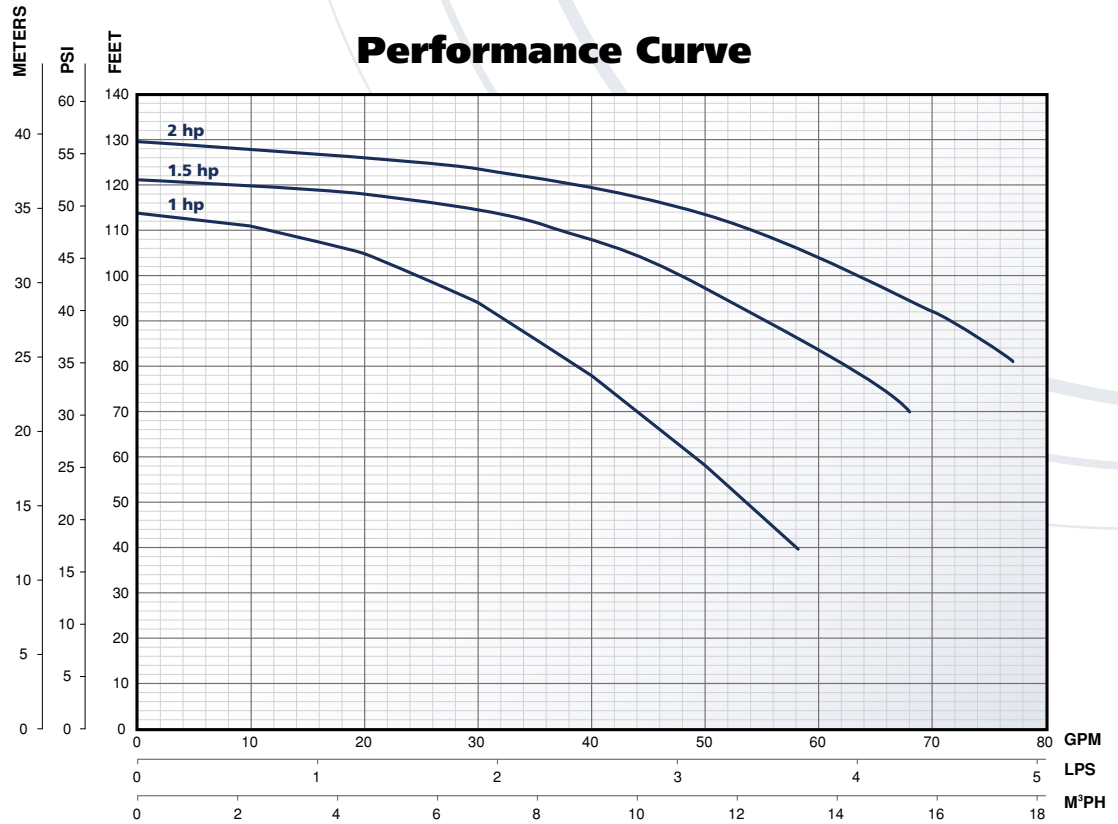

## Performance Data

Model	Suction Lift Ft.	Discharge Pressure - PSI							Shut-Off Pressure PSI
		20	25	30	35	40	45	50	
		Gallons per Minute							
FTB1CI	5	53	47	42	36	27	13	-	46
	10	49	45	38	32	23	-	-	44
	15	45	43	37	28	17	-	-	42
	20	38	37	33	24	-	-	-	40
	25	28	27	27	18	-	-	-	38
FTB15CI	5	65	64	63	58	48	37	-	50
	10	58	58	57	55	45	26	-	48
	15	50	49	48	48	40	-	-	46
	20	41	40	39	38	32	-	-	44
	25	29	28	28	27	17	-	-	42
FTB2CI	5	70	69	69	68	65	53	35	52
	10	61	60	60	59	58	47	-	50
	15	52	51	50	49	48	37	-	49
	20	41	40	39	38	35	-	-	47
	25	29	28	27	25	22	-	-	45



**Franklin Electric**

400 East Spring Street, Bluffton, IN 46714

Tel: 260.824.2900 • Fax: 260.824.2909

[www.franklin-electric.com](http://www.franklin-electric.com)