

Please read and save this Repair Parts Manual. Read this manual and the General Operating Instructions carefully before attempting to assemble, install, operate or maintain the product described. Protect yourself and others by observing all safety information. The Safety Instructions are contained in the General Operating Instructions. Failure to comply with the safety instructions accompanying this product could result in personal injury and/or property damage! Retain instructions for future reference.

# Small Straight Centrifugal Pedestal Pumps

Refer to form 1808-635-00 for General Operating and Safety Instructions.

## Description

These pumps are for continuous duty, low pressure applications that do not require self-priming. Discharge port rotates 360° in 90° increments. Pumps incorporate a mechanical shaft seal and o-ring casing seal. All units for use with nonflammable, non-abrasive liquids compatible with pump component materials.

### 316 STAINLESS STEEL UNITS

Pump construction is cast 316 stainless steel with shaft seal of stainless steel, carbon, ceramic, and Viton elastomers. Handle liquids from 40° to 200° F (4° to 93° C).

### BRONZE UNITS

Pump construction is cast bronze with cast 316 stainless steel impeller. Includes shaft seal of stainless steel, carbon, ceramic, and Viton elastomers. Handle liquids from 40° to 200° F (4° to 93° C).

### CAST IRON UNITS

Pumps are cast iron with cast 316 stainless steel impeller. Shaft seal is stainless steel, carbon, ceramic, and Buna N elastomers. Handle liquids from 40° to 180° F (4° to 82°C).

## Maintenance

**▲WARNING** Make certain that unit is disconnected from power source before attempting to service or remove any components!

### MECHANICAL SEAL REPLACEMENT

Refer to Figure 2.

**IMPORTANT:** Always replace both seal seat (Ref. No.8) and seal head (Ref. No. 7) to insure proper mating of components! Also, impeller seal (Ref. No. 10) should be replaced anytime impeller fastener (Ref. No. 11) has been removed.

1. Remove fasteners (Ref. No. 14) connecting casing (Ref. No. 13) to pedestal (Ref. No. 5).
2. Remove casing and casing seal (Ref. No. 12).

**▲CAUTION** Care should be taken not to "pinch" or "shave" casing seal between pedestal and casing.

3. Use a box and/or socket wrench to remove impeller fastener. Remove impeller seal and impeller (Ref. No. 9). Seal seat can now be pried from impeller.

**IMPORTANT:** Care should be taken to insure that same number and thickness of shim washers (Ref. No. 8A) are replaced behind impeller as was removed. Shim washers are located directly behind impeller and become loose as impeller is removed.

4. To free shaft assembly (Ref. No. 4), see "Bearing Housing Service".
5. After shaft assembly is removed, press seal head from pedestal.

## Performance

Model	Port Size	Pump RPM	BHP Required	GPM of Water at Total Head in Feet						Max. ** Head
				10'	20'	30'	40'	50'	60'	
3682	3/4" x 1/2"	3450	0.58	36	32	27	20	9	–	57 ft.
		3000	0.33	30	25	17	5	–	–	42
		2600	0.25	24	16	1	–	–	–	31
		1750	0.25	8	–	–	–	–	–	13
3704	1" x 3/4"	3450	1.13	57	51	43	35	21	0	60
		3000	0.65	48	39	30	15	–	–	46
		2600	0.25	37	21	4	–	–	–	32
		1750	0.25	17	–	–	–	–	–	14
3694	1 1/4" x 1"	3450	2.00	88	81	72	62	48	25	68
		3000	1.50	75	65	53	38	5	–	51
		2600	0.75	62	49	25	–	–	–	37
		1750	0.25	27	–	–	–	–	–	17

\*\* Shut-off; to convert to PSI, divide by 2.31.

# Small Straight Centrifugal Pedestal Pumps

## Dimensions

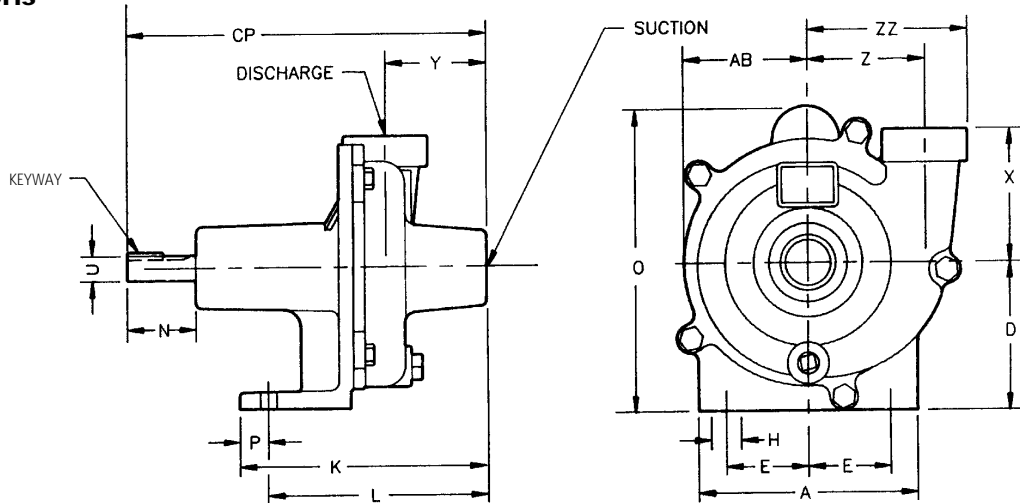

Figure 1

Model No.	Suc**	Dis**	AB	CP	D	E	H	K	L	N	O	P	U	X	Y	Z	ZZ	Keyway
3682	3/4"	1/2"	2.25	6.69	3.22	1.50	0.34	3.56	2.94	1.31	6.13	0.62	5/8"	1.88	1.44	1.88	2.88	3/16" x 1"
3704	1	3/4	2.75	6.75	3.22	1.50	0.34	3.62	3.00	1.31	6.62	0.62	5/8	2.38	1.41	2.09	3.31	3/16 x 1
3694	1 1/4	1	2.75	6.75	3.22	1.50	0.34	3.62	3.00	1.31	6.62	0.62	5/8	2.50	1.28	2.03	3.38	3/16 x 1

**NOTE:** All dimensions have a tolerance of  $\pm 1/8"$ .  
 (\*\*) Standard NPT (female) pipe thread.

## Maintenance (Continued)

**CAUTION** *The precision lapped faces on mechanical seal are easily damaged. Handle your replacement seal carefully. Do not touch polished seal faces.*

**IMPORTANT:** Be sure that shaft shoulder does not damage polished seal face.

- Thoroughly clean all surfaces of seal seat cavity in pedestal and impeller.
- While wearing clean gloves or using a clean light rag, press seal head squarely into pedestal recess, use cardboard washer (usually supplied with new seal), place over polished surface and use a piece of pipe or dowel rod to press in firmly, but gently. Avoid scratching polished face.
- Dispose of cardboard washer. Check again to see that polished surface is free of dirt and all other foreign

particles and that it has not been scratched or damaged.

- Wet rubber portion of new seal seat with a light coating of soapy water. While wearing clean gloves or using a clean light rag, press seal seat squarely into impeller recess, use cardboard washer (usually supplied with new seal), place over polished surface and use a piece of pipe or dowel rod to press in firmly, but gently. Avoid scratching polished face.

**NOTE:** A short "run-in" period may be necessary to provide completely leak-free seal operation.

- Replace any shim washers which may have been removed in disassembly.
- Screw impeller back in place, tightening until it is against shaft shoulder. Install impeller seal and impeller fastener.

- Remove casing seal and casing on pedestal.

**IMPORTANT:** Always inspect casing seal (Ref. No. 12) whenever unit is disassembled. Replace when cracked or worn.

**IMPORTANT:** After pump is completely assembled it is necessary to rotate pump shaft by hand to check for striking of impeller. If striking or rubbing occurs, adjust impeller shims as required (see "Shim Adjustment").

### BEARING HOUSING SERVICE

- Remove casing (Ref. No. 13) and impeller (Ref. No. 9) as described under "Mechanical Seal Replacement".
- Remove shaft assembly (Ref. No. 4) by first removing snap ring (Ref. No. 1) and shims (Ref. No. 2). Push shaft assembly out of pedestal by rapping on threaded end of shaft

## Models 3682, 3694 and 3704

---

### Maintenance (Continued)

with a soft mallet, or block of wood and a hammer. Slinger washer (Ref. No. 6) will come loose at this time.

3. Replace shaft assembly by sliding assembly into pedestal (be sure to align slinger washer), threaded end first. Push assembly completely in by gently tapping on keyway end of shaft with a soft mallet. Replace shims and snap ring.
5. Reassemble pump as described under "Mechanical Seal Replacement".

### SHIM ADJUSTMENT

When installing a replacement impeller (Ref. No. 9) or shaft assembly (Ref. No. 4), it may be necessary to

adjust number of shims (Ref. No. 8A) to insure proper running clearance between impeller and casing (Ref. No. 13). Proceed as follows:

**NOTE:** A proper running clearance is less than 0.010".

1. For impeller replacement, add one 0.010" shim in addition to those removed originally.
2. For shaft assembly replacement, add two 0.010" shims in addition to those removed during disassembly.
3. Reassemble pump using "Mechanical Seal Replacement" for reference.

**IMPORTANT:** Insure that casing is snugly in place and check shaft to make sure it is turning freely. If it turns freely, check to insure that pedestal

(Ref. No. 5) and casing are fitted "metal to metal" where they meet on outside. If they are not "metal to metal" tighten fasteners (Ref. No. 14) and recheck shaft for free turning. Tighten carefully turning shaft while tightening so that bearings are not damaged in the event that too many shims were installed. If shaft seizes before fasteners are completely tight, disassemble pump and remove one 0.010" shim and repeat reassembly.

**For Repair Parts, contact dealer where pump was purchased.**

Please provide following information:

- Model number
- Serial number (if any)
- Part description and number as shown in parts list

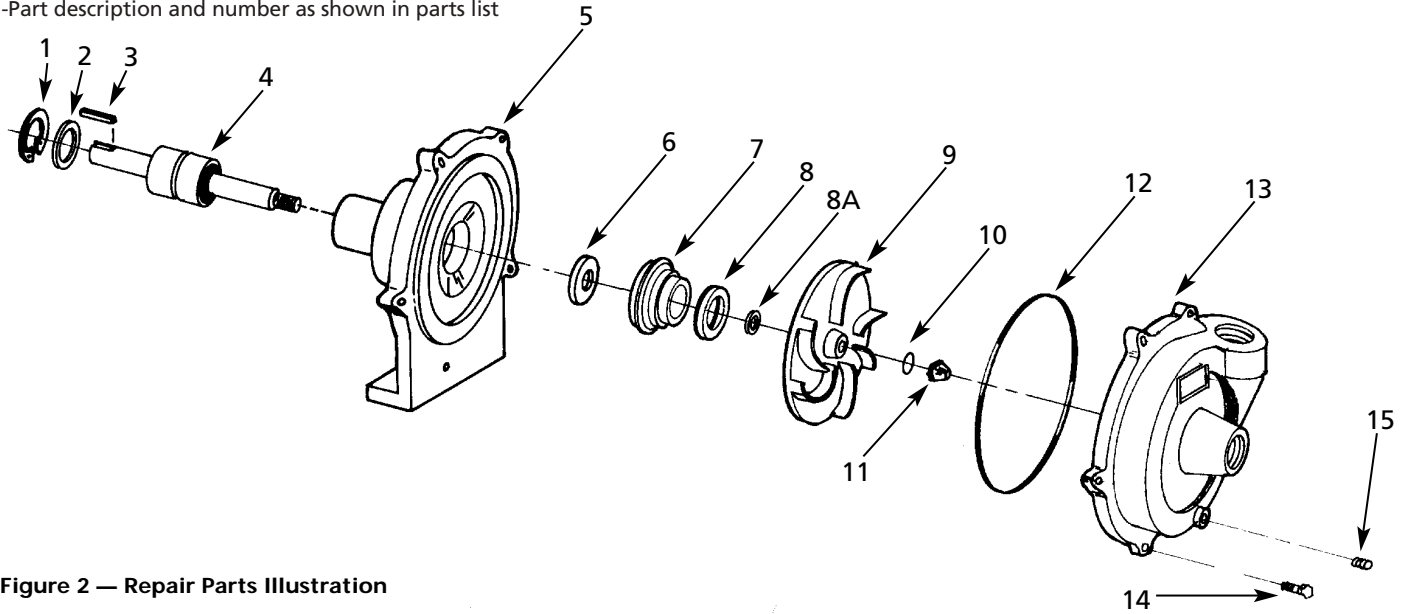

Figure 2 — Repair Parts Illustration

**Repair Parts List**

Ref. No.	Description	Part Number For Models:			Qty.
		3682	3704	3694	
1	Snap ring	1806-062-00	1806-062-00	1806-062-00	1
2	Bearing shim package	1806-012-90	1806-012-90	1806-012-90	1
3	Shaft key	1517-000-00	1517-000-00	1517-000-00	1
4	Shaft and bearing ass'y -for cast iron & bronze pumps -for stainless steel pumps	1509-000-09 3682-140-00	1509-000-09 3682-140-00	1509-000-09 3682-140-00	1
5	Pedestal -cast iron -bronze -stainless steel	3682-091-09 3682-092-09 3682-090-09	3694-091-09 3694-092-09 3694-090-09	3694-091-09 3694-092-09 3694-090-09	1
6	5/8" Slinger washer	1534-000-00	1534-000-00	1534-000-00	1
7 & 8 †	Seal assembly -Buna N -Viton	1640-161-92 1640-161-95	1640-161-92 1640-161-95	1640-161-92 1640-161-95	1
8A	Impeller shim kit (includes 0.005", 0.020", 0.030")	1806-044-90	1806-044-90	1806-044-90	1
9	Impeller	3680-010-98	3700-010-09	3690-010-09	1
10	O-ring -Buna N -Viton	2105-036-00 2105-037-00	2105-036-00 2105-037-00	2105-036-00 2105-037-00	1
11	7/16"-20 UNF SS acorn nut	1784-001-00	1784-001-00	1784-001-00	1
12	O-ring -Buna N -Viton	1582-000-00 1532-000-00	1582-000-00 1567-001-70	1582-000-00 1567-001-00	1
13	Casing -cast iron -bronze -stainless steel	3680-002-09 3680-003-09 3680-001-09	3700-002-09 3700-003-09 3700-001-09	3690-002-09 3690-003-09 3690-001-09	1
14	1/4"-20 UNC x 7/8" hex head cap screw 5/16"-18 UNC x 7/8" hex head cap screw	* —	— *	— *	5 5
15	1/8" pipe plug	*	*	*	1

(†) Sold only as assembly.

(\*) Standard hardware item, available locally.

(\*\*) When replacing a seal assembly, a new impeller O-ring should be used.