

RUN DRY UTILITY PUPPIES

MODELS:

23920-9403 / 9503 12 / 24V RUN DRY UTILITY PUPPY
23920-9213 / 9313 12 / 24V RUN DRY UTILITY PUPPY

FEATURES:

Continuous rated, heavy duty, dry running pumps for bilge, deckwash and general purpose use.

- Meets USCG Regulation 183.410 and ISO 8846 MARINE (Ignition protection).
- ISO 8849 MARINE (Bilge pump standard).
- Bilge debris present no problem to these bronze bodied, flexible impeller pumps.
- Simple design means fewer wearing parts.

Run Dry Utility Puppy 23920-9403 / 9503

- 390 gph output.
- Twenty minutes dry running (after initial prime).
- Self priming to 4 ft.

Run Dry Utility Puppy 23920-9212 / 9313

- 612 gph output.
- Ten minutes dry running (after initial prime).
- Self priming to 8 ft.
- Long life mechanical seal.

INSTALLATION INSTRUCTIONS:

Jabsco Utility Puppies can be mounted on any flat surface. Fit the pump in a dry, well ventilated position where there is full access for service. If installed in a vertical position the motor must be above the pump head. Use the rubber grommets provided to minimise vibration, do not overtighten the mounting screws.

3/4" NPT threaded fittings should be used to connect 1" i.d. suction and discharge hoses. Secure the hose to the fittings with stainless steel hose clamps. Use spiral reinforced hose (with a smooth internal bore) that will not collapse under suction, or rigid or semi rigid pipework systems. The pipework must be compatible with the liquid being pumped. Pipe runs should be kept as straight and short as possible, avoiding rising and dipping over obstructions. Fit an inlet strainer on the inlet hose to prevent blockage.



WARNING: All marine pumps discharging overboard must be installed with the overboard discharge well above both static and heeled waterlines.

WIRING INSTRUCTIONS

Make all electrical connections in dry locations, connections in humid environments should be sealed to prevent corrosion. Protect the circuit with a correctly sized fuse or circuit breaker in the positive (+) lead as close as possible to the power source. Select the correct cable size from the chart below. Inadequate voltage at the motor terminals when the pump is running (not less than 10% below rated voltage at full load) due to partially discharged batteries or insufficient cable size may result in blowing fuses, failure to start or poor pump performance.

Connect the black motor wire to the negative (-) battery terminal. The red wire should run via a suitably rated switch or circuit breaker to the positive (+) battery terminal.



WARNING: If the fuse fails repeatedly do not fit a heavier fuse or bridge the fuse terminals with silver paper or metal wire. Failure to observe this instruction may result in a fire hazard due to overheating of cables.

RUN DRY UTILITY PUPPY PERFORMANCE		
Approximate performance for new pump, pumping water at 20°C, with fully charged battery		
Total Manometric Head	23920-9403 23920-9503	23920-9213 23920-9313
ftH ₂ O	gpm	gpm
0	10	13.2
3.5	9.6	12.6
7	9.3	12
13	8	10.8
20	6.6	10
26		9
33		8
39		6.6



ELECTRICAL WIRING INFORMATION					
Model No.	Voltage	Amp Draw	Max. Fuse Size	Min. Wire Size AWG	Max. Length of wire between (+) & (-) battery terminals
23920-9213	12V	21 amp	25 amp	10 8	up to 20ft over 20 ft
23920-9313	24V	11 amp	15 amp	12 10	up to 20ft over 20 ft
23920-9403	12V	13 amp	15 amp	14	15ft
23920-9503	24V	7.5 amp	10 amp	14	15ft

EXPLODED VIEW & PARTS LIST

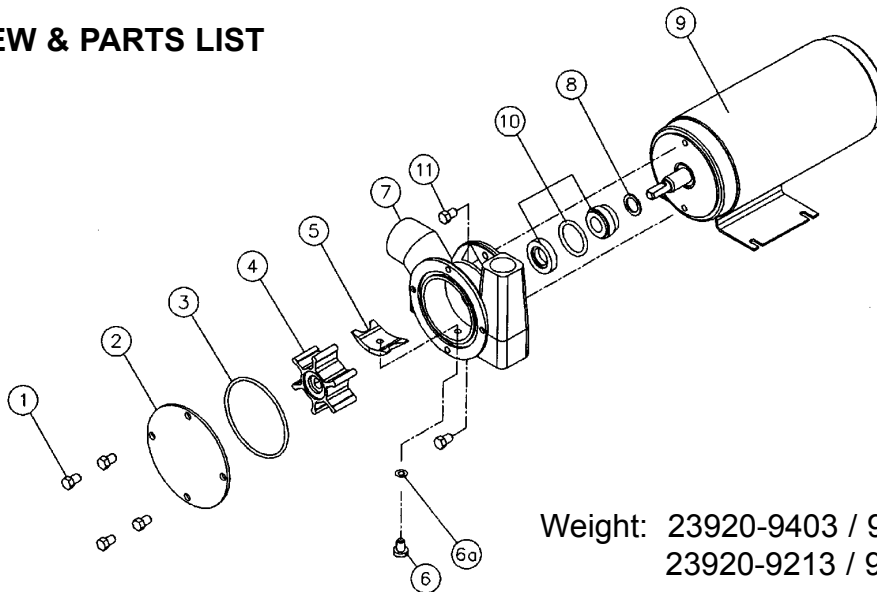

Weight: 23920-9403 / 9503 7lb
23920-9213 / 9313 10lb

RUN DRY UTILITY PUPPY PARTS					
KEY	DESCRIPTION	23920-9213 / -9313		23920-9403 / -9503	
		QTY	PART NUMBER	QTY	PART NUMBER
1	End Cover Screws	4	X3001-147F	4	X3001-147F
2	End Cover	1	23825-0000	1	23825-0000
3	End Cover Seal	1	X4020-257A	1	X4020-257A
4	Impeller - Nitrile	1	7273-0003	1	6303-0003
5	Cam	1	53023-0000	1	53023-0100
6	Cam Screw	1	X3002-147F	1	X3002-147F
6a	Cam Screw Seal	1	X4020-105A	1	X4020-105A
7	Pump Body	1	53024-9000	1	53024-9100
8	Slinger	1	6342	1	6342
9	Motor	1		1	
	Standard Impeller 12V		SP8012-0261		SP8012-0165
	Standard Impeller 24V		SP8012-0262		SP8012-0166
10	Mechanical Water Seal	1	SP8012-0301B		
	Lip Type Water Seal			1	SP2701-52
11	Pump Motor Screws	2	X3001-147F	2	X3001-147F

Jabsco



ITT Industries

Jabsco, 20 Icon, Foothill Ranch, CA 92610

Tel : +1 949 609 5106

Fax : +1 949 859 1153

USA

Jabsco, Bingley Road, Hoddesdon, Hertfordshire, EN11 0BU

Tel : +44 (0) 1992 450 145

Fax : +44 (0) 1992 467 132

UK

Fluid Products Canada, 55 Royal Road, Guelph, Ontario N1H 1T1

Tel : +1 519 821 1900

Fax : +1 519 821 5316

CANADA

NHK Jabsco Co Ltd, 3-21-10, Shin - Yokohama, Kohoku-ku, Yokohama 222

Tel : +81 (0) 45 475 8906

Fax : +81 (0) 45 475 8908

JAPAN

Jabsco GmbH, Oststraße 28, 22844 Norderstedt

Tel : +49 (0) 40 53 53 73 0

Fax : +49 (0) 40 53 53 73 11

GERMANY

Warranty: All products of the company are sold and all services of the company are offered subject to the company's warranty and terms and conditions of sale, copies of which will be furnished upon request.