

Myers®

Pentair Pump Group

I2C & I2CI/2C95 Two-Stage Centrifugal Pumps Installation, Servicing and Parts List

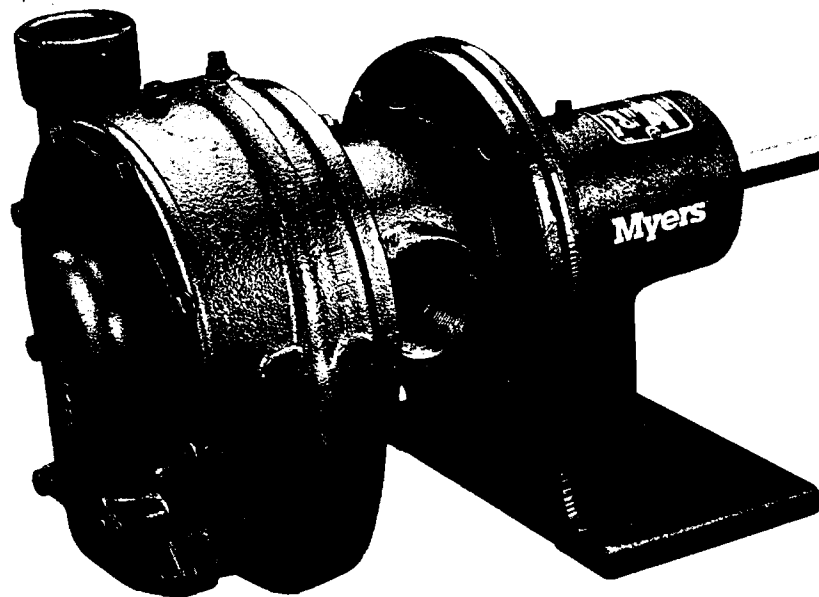

INDUSTRIAL HIGH CAPACITY, HIGH PRESSURE, TWO STAGE CENTRIFUGAL PUMP "I2C" PUMP UNIT ONLY; "I2CB" BASE MOUNTED, DIRECT CONNECTED; "I2CB-M" BASE MOUNTED, DIRECT CONNECTED, COMPLETE W/MOTOR

Location

The pump should be located in an easily accessible place as close to the liquid source as possible. It should be installed in a clean, dry, well ventilated place, allowing room to inspect and service pump and driver.

Foundation

The pump should be bolted securely to a rigid foundation, either concrete or steel. The 2" N.P.T. Suction can be rotated at 90° intervals to 4 different positions. As standard, the suction will be on the right side when facing the pump end. The 1½" N.P.T. Discharge can be rotated at 45° intervals to 8 different positions. As standard, the discharge will point up.

Direct connected pumps should always be mounted in a horizontal position on a level foundation. It is the best practice on permanent installations to grout the baseplate in place, this is particularly important with the larger motors. The unit should be set in place with wedges under each corner, near the foundation bolts. Adjust wedges and foundation bolts until the baseplate is level, in proper relation to the piping so the flexible coupling halves are aligned. About ¼" should be allowed under the baseplate for grouting. The foundation bolts should be drawn up evenly until snug. When the alignment is correct grout the unit in place. Do not tighten foundation bolts or connect piping until grout is thoroughly set.

Alignment

Direct connected units are accurately aligned at the factory but all baseplates are flexible to some extent and, therefore, must not be relied upon to maintain the factory alignment. A flexible coupling is intended to take care of only slight misalignment. Therefore the pump and driver must be carefully aligned at the installation. Parallel alignment can be checked by placing a straight edge across the coupling halves. It must rest evenly on both halves at four positions spaced at approximately 90° intervals around the coupling. Angular alignment can be checked with a feeler gauge between the coupling halves at four points at approximately 90° intervals around the coupling. The coupling halves are positioned on the shafts so there is a gap of 3/32" between the jaw of one half and the body of the other half.

On belt driven units the pump and driver shafts should be parallel; the pulleys or sheaves must be aligned also. This can be checked by placing a long straight edge or tight string across the edges of the pulley or sheaves. The pulley or sheave on both pump and driver should be mounted as close to the bearing housing as possible to minimize the overhang, allowing sufficient clearance for rotor and play.

Belt Drives

Avoid a vertical drive on flat belt drives; an angle of 45° or less between the line of shaft centers and the horizontal is desirable. Normally the belt speed should not exceed 5000 feet per minute and the pulley ratio should not

exceed 5 to 1. The distance between the shaft centers should be at least twice the diameter of the larger pulley. Wide, single ply flat belts are preferable to double ply belts due to the lower bearing pressures that result. Adjust belt tension just tight enough to prevent slippage; excess tension unnecessarily loads the bearings. V-belts do not require as much tension as flat belts.

Piping

Pipes must line up and not be forced into position by unions. Piping should be independently supported near the pump so that no strain will be placed on the pump casing. Where any noise is objectionable, pump should be insulated from the piping with rubber connections. Always keep pipe size as large as pump tapings or larger and use a minimum of fittings to reduce friction losses.

Suction Piping

Suction pipe should be direct and as short as possible. It should be at least one size larger than suction inlet tapping, which would make it 2½" minimum. It should have a minimum of elbows and fittings. The piping should be laid out so that it slopes upward to pump without dips or high points so that air pockets are eliminated. The highest point in the suction piping should be the pump inlet except where liquid flows to the pump inlet under pressure. A foot valve can be used to keep pump primed. Where liquid flows to the pump, it may be desirable to use a check valve in the suction line or discharge line to keep pump primed.

To prevent air from being drawn into suction pipe due to a suction whirlpool, the foot valve should be submerged at least three feet below the low water level. The suction pipe must be tight and free of air leaks or pump will not operate properly.

- Maximum suction pressure is 75 psi
- Special mechanical seal available for suction lifts over 21 feet

Discharge Piping

Discharge piping should never be smaller than pump tapping and should preferably be one size larger. A gate valve should always be installed in discharge line to serve as a shut-off or throttling valve if capacity is not correct. To protect the pump and foot valve from water hammer and to prevent backflow, a check valve should be installed in the discharge line between the pump and gate valve.

- Maximum discharge pressure is 300 psi

Electrical Connections

Be sure motor wiring is correct for voltage being used. Always use separate fused switch for pump, and wire of sufficient size to keep voltage drop to a maximum of 5%. All motors, unless provided with built-in overload protection, must be protected with an overload switch, either manual or magnetic. This switch to be supplied by customer. Never install a pump without proper overload protection. Check local code requirements.

When the motor is mounted on a baseplate or on slide rails for adjustment, flexible metallic conduit should be used to protect the motor leads.

Priming

The pump must be primed before starting. Be sure pump case is filled with water before operating. The mechanical shaft seal must never be run dry. Remove the three top 1/4" pipe plugs while priming (one in each chamber) to assure that all air is evacuated. The three individual chambers of the pump and the suction piping must be completely filled before starting motor.

If pump does not start immediately, stop and reprime.

Rotation

The pump must run in direction of arrow on pump case. Three phase motors may run either direction so if rotation is wrong when first starting motor, interchange any two line leads to change rotation.

Starting

With all piping connected to the pump and the unit tightened down in place, check the alignment. If misalignment is apparent after grout has set, it must be corrected by placing shims under pump or driver. If the alignment is correct and the pump turns freely by hand, the unit is ready to start after it is primed.

It is good practice to close the discharge valve when starting the pump as it puts less starting load on the motor. When the pump is up to operating speed, open the discharge valve to obtain desired capacity or pressure. Do not allow the pump to run for long periods with the discharge valve tightly closed. If the pump runs for an extended period of time without liquid being discharged, the liquid in the pump case can get extremely hot.

Stopping

Before stopping pump, close the discharge valve. This will prevent water hammer and is especially important on high head pumps. A properly installed check valve will perform the same function.

Mechanical Seal Lubrication

The pump is provided with an oil chamber which lubricates the seal face of the mechanical seal. The oil level should be checked every 50 hours. Fill cavity through the oil cup (item 30) with S.A.E. No. 30 oil.

NOTE: If the suction bracket is rotated to a different position, the oil cup must be removed and rotated so it will remain in a vertical position.

Bearings - Lubrication

Lubricate electric motor bearings in accordance with the manufacturer's instructions.

Pump bearings are sealed one side, open one side ball bearings that are lubricated by grease in the bearing bracket. Normally, these bearings require no further attention. This grease cavity must not be overloaded and should not be filled more than about half full. Dolium R or equivalent grease must be used.

If, due to unusual operation conditions, it becomes necessary to revitalize the grease, proceed as follows:

1. Remove bearings and shaft. (See instructions on "To Replace Bearings.")

2. Clean out cavity between bearings.
3. Replace bearings and pump shaft. **NOTE:** Bearing open sides should face in toward grease cavity with seals facing out.
4. Fill cavity about 1/2 full (approximately 1/2 pound) of Dolium R or equivalent through top 1/4" NPT.

Freezing

Care should be taken to prevent the pump from freezing during cold weather. It may be necessary, when there is any possibility of this, to drain the pump when not in operation.

Three individual chambers must be drained. These chambers include the suction (seal bracket) and the first and second stage impeller chambers.

- A. To drain the suction chamber, remove the 1/4" pipe plug that is in the bottom position, unless the suction pipe is pointing down. If this is the case, drainage means must be provided in suction piping leading to the pump.
- B. To drain the first and second stage impeller chambers, remove the two 1/4" pipe plugs which are in the lower position of the case and the 1/8" pipe plug in the crossover casting.

To Remove and Replace Worn Impeller and Wearing Rings

To service pump, the suction and discharge piping must first be disconnected.

- A. Remove back plate (25). Remove impeller cap screw (17) and washer in outer impeller eye. Remove tap bolts which hold volute case (21) to bracket (7). With two large screwdrivers on opposite sides of volute case, pry evenly and carefully to get volute case and outer impeller off. Care must be exercised to avoid bending pump shaft. In the event that the impeller is extremely difficult to pull, it can be expanded by warming with a torch. Be careful not to get it really hot. Then, before it has time to conduct heat to shaft, the impeller can be pried off with two screwdrivers, as described previously.
- B. Remove inner impeller (13) using two screwdrivers and heat, if necessary. Be careful not to get shaft hot. Remove snap ring (12). Slide old seal (11) off shaft. Remove tap bolts (5) holding bracket (7) to bearing bracket (1) and pull bracket off shaft. Remove old floating seat and seat cup from bracket.
- C. Make sure the synthetic seat cup of the new seal is tight against the shoulder of the floating seat, with rounded edge at the rear to facilitate insertion. The seal is assembled this way when shipped. Wipe the lapped sealing face of the floating seat perfectly clean and oil face with a clean, light oil.
- D. Oil outer surface of the seat cup, using light oil (not grease) and push this assembly in the cavity of the bracket, seating it firmly and squarely. If necessary to use a piece of tubing to push it in, bear on the outer edge of the floating seat, never on the lapped sealing face.

- E. Replace lip seal (2) and lubricate oil seal face with S.A.E. No. 30 oil. Clean and oil the surface of the shaft with a light oil. Make sure slinger (10) is in place. Bolt (30 ft-lbs) bracket (less impellers) back on to bearing bracket, being careful not to strike floating seat with shaft. Wipe the face of the sealing washer perfectly clean, and oil with clean light oil. It is extremely important that only clean oil be used on the sealing faces. Any dirt whatsoever may cause seal failure. Put the sealing washer and bellows assembly on the shaft. Be sure sealing washer is in proper position. The notches on the washer should mate with lugs on the retainer. Use a sleeve of proper diameter to slide assembly into place. Note: When sliding seal assembly on shaft, be sure to press only on tail sections of bellows and driving band. A smooth sleeve of about 1-9/32" diameter (1/32" larger than shaft), with a wall thickness of about 1/2" is suitable. Press assembly on until it is tight against floating seat.
- F. Slip shaft seal spring over shaft, making sure that it, and the spring holding plate, are seated properly. Slip snap ring over shaft and slide it forward until it drops into place. Install inner impeller, with suction opening toward bearing bracket, making sure that key is in place on shaft. The inner and outer impellers have different wearing ring diameters. Therefore, it is impossible to assemble impellers in reverse order.
- G. Place volute case back and bolt it to bracket torquing bolts to 30 ft. lbs. Install outer impeller with suction opening away from bearing bracket. Ring the beveled washer (shaft side) with a bead of Permatex to seal keyway and impeller shaft from corrosion. Assemble the impeller cap screw, with a 3/8" helical spring lock washer (302 stainless steel). Myers part number 05454A007. Tighten the cap screw to 35 foot/pounds.
- H. Be sure pump case is filled with water before operating. Seal must never be run dry.

Replacing Wear Rings

With impellers removed, the wearing rings can be examined for wear. Replace wearing rings if clearance on diameter is over .030".

To remove and replace wearing rings:

1. Cut worn rings from casing with cold chisel. Be careful not to cut or damage the iron castings when removing rings. Cut rings nearly in half on opposite sides, then they can be easily bumped out.
2. Put new rings in place and bump in with a hardwood block. New impeller wearing rings should always be installed in a pump at the same time a new impeller is installed. Worn wearing rings will cause excessive wear on the new impeller, thereby reducing the amount of service obtained from a new impeller.

To Replace Bearings

Pump end must be removed. Pry pulley and bearing retaining ring out with a screwdriver. Press shaft and bearings through pulley end of bearing bracket. Press bearings off shaft.

To reassemble: Press new bearings on shaft, pressing only on inner race of bearings. Insert shaft into housing. Also seals on bearings must face out on installation with open sides facing in (toward grease cavity). Replace snap rings. Beveled snap ring goes on pump end bearing, with bevel facing pump end.

SERVICE CHART TROUBLESHOOTING GUIDE

POSSIBLE CAUSE OF PROBLEM	D	C	B	A
A. No water delivered.				X
B. Not enough water delivered.				X
C. Not enough pressure.				X
D. Pump runs for short while, then loses prime.				X
1. Pump not properly primed, repeat priming operation			X	X
2. Discharge head too high. Check total head with gauge at pump inlet and discharge. (With water, the gauge would show shut-off pressure.)			X	X
3. Excessive volume being discharged. Throttle discharge valve.		X		
4. Speed too low. Check pump drive belts for slippage. If hot, tighten belts. Check motor voltage and speed.		X	X	
5. Rotation wrong. Change shaft rotation.		X	X	X
6. Suction lift too high. Check with vacuum gauge. This should not exceed 15 feet. When pumping hot water recheck NPSH.	X		X	X
7. Air leak in suction line. Check line under pressure to find leak.	X	X	X	X
8. Air pocket in suction line. Check line for proper slope.	X			X
9. Insufficient submergence of suction pipe. Foot valve should be three feet below water level.	X		X	
10. Sediment chamber clogged. Remove and clean thoroughly. Make sure gasket is in good condition and sealing surfaces clean before reassembly of sediment chamber cap.		X		
11. Impeller or suction line plugged.		X	X	X
12. Impeller and wearing rings badly worn. Disassemble pump and replace impeller and wearing rings if clearance on diameter is over .030"		X	X	
13. Suction strainer plugged. Clean strainer.	X			
14. Impeller diameter too small for condition required.		X	X	
15. Seal leaking - seal is worn or seal face cocked. Replace with new seal and carefully follow directions.				

I2C & I2CI/2C95 Parts List

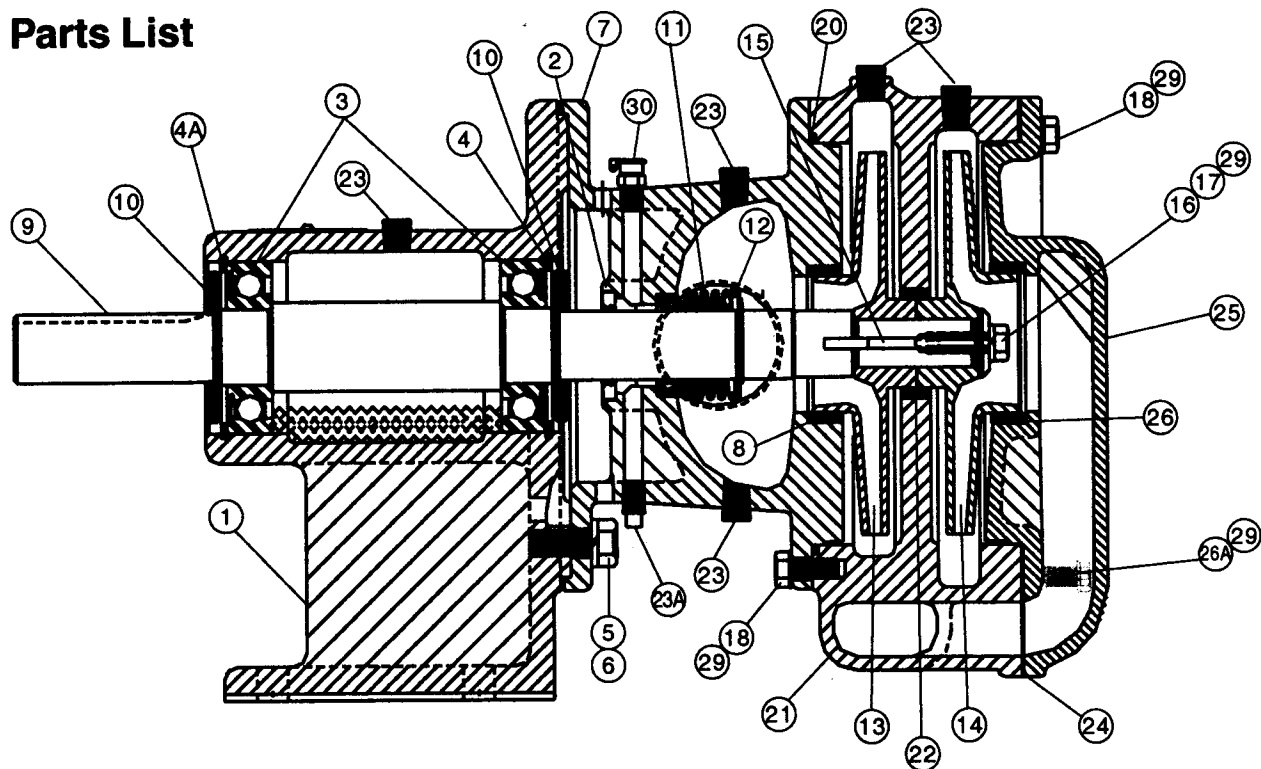

Ref. No.	Part No.	Description	Qty. Req'd.
1	15035D000	Bracket, Bearing	1
2	05710A022	Seal, Lip	1
3	11729A008	Bearing, Ball	2
4	07756A001	Ring, Retaining, Bevel	1
4A	07756A012	Ring, Retaining	1
5	19103A004	Screw, 1/2-13UNC x 1-1/4 Hex Hd.	4
6	05454A004	Washer, 1/2 Lock	4
7	17548D001	Bracket, Seal, w/Brass Wear Ring - I2C Units	1
	17548D010	Bracket, Seal, w/Ni-Resist Wear Ring - I2CI Units - Replaces 17548D001 on 2C95	1
8	12934A000	Ring, Wear, Brass - I2C Units	1
	12934A001	Ring, Wear, Ni-Resist - I2CI Units - Replaces 12934A000 on 2C95	1
9	15037C000	Shaft	
10	05059A263	Slinger	2
11	21181A016	Seal, Rotary - Replaces 15218A000 & 15218A010 on I2C, I2CI & 2C95 - Replaces 21181A008 on I2CH Units	1
12	12558A008	Ring, Retaining	1
13	17549C004	Impeller, 4-11/16" Dia., Brass - I2C-5	1
	17549C003	Impeller, 5-5/16" Dia., Brass - I2C-7	1
	17549C002	Impeller, 5-7/8" Dia., Brass - I2C-10	1
	17549C001	Impeller, 6-11/16" Dia., Brass - I2C-15	1
	17549C000	Impeller, 7" Dia., Brass - I2C-20	1
	15038C004	Impeller, 4-11/16" Dia., C.I. - I2C-5	1
	15038C003	Impeller, 5-5/16" Dia., C.I. - I2C-7	1
	15038C002	Impeller, 5-7/8" Dia., C.I. - I2C-10	1
	15038C001	Impeller, 6-11/16" Dia., C.I. - I2C-15	1
	15038C000	Impeller, 7" Dia., C.I. - I2C-20/2C95	1
14	17550C004	Impeller, 4-11/16" Dia., Brass - I2C-5	1
	17550C003	Impeller, 5-5/16" Dia., Brass - I2C-7	1
	17550C002	Impeller, 5-7/8" Dia., Brass - I2C-10	1
	17550C001	Impeller, 6-11/16" Dia., Brass - I2C-15	1
	17550C000	Impeller, 7" Dia., Brass - I2C-20	1
	15039C004	Impeller, 4-11/16" Dia., C.I. - I2C-5	1
	15039C003	Impeller, 5-5/16" Dia., C.I. - I2C-7	1
	15039C002	Impeller, 5-7/8" Dia., C.I. - I2C-10	1
	15039C001	Impeller, 6-11/16" Dia., C.I. - I2C-15	1
	15039C000	Impeller, 7" Dia., C.I. - I2C-20/2C95	1

Ref. No.	Part No.	Description	Qty. Req'd.
15	05818A046	Key, 3/16 Sq. x 2" SST	1
16	08818A002	Washer, 3/8" SST Special	1
17	17050A001	Screw, 3/8-16 UNC x 1" SST Nylok Hex Head	1
18	19101A011	Screw, 3/8-16 UNC x 7/8" Hex Hd.	16
20	05876A127	O-Ring	1
21	17547D001	Case, Volute, w/Brass Wear Ring - I2C Units	1
	17547D010	Case, Volute, w/Ni-Resist Wear Ring - I2CI Units - Replaces 17547D001 on 2C95	1
22	15044A000	Ring, Wear, Brass - I2C Units	1
	15044A001	Ring, Wear, Ni-Resist - I2CI Units - Replaces 15044A000 on 2C95	1
23	05022A056	Plug, 1/4 NPT Galv. Pipe	13
23A	05022A021	Plug, 1/8 NPT Galv. Pipe	1
24	15041B010	Gasket	1
25	15042D001	Plate, Back, w/Brass Wear Ring - I2C Units	1
	15042D010	Plate, Back, w/Ni-Resist Wear Ring - I2CI Units - Replaces 15042D001 on 2C95	1
26	15043A000	Ring, Wear, Brass - I2C Units	1
	15043A001	Ring, Wear, Ni-Resist - I2CI Units - Replaces 15043A000 on 2C95	1
26A	19101A028	Screw, 3/8-16 UNC x 2" Hex Hd. (hidden)	2
29	05454A007	Washer, 3/8" SST Lock	19
30	20362A001	Cup, Oil, 1/8 NPT	1

Leaking case bolts may be sealed by using o-ring washers p/n 14946A003, instead of lock washers. *Alternative - Seal bolt threads with teflon tape or loclite.*

If volute case (21) does not have a groove for o-ring (20), use gasket (24) - trim excess detail or upgrade with kit I2C-CK.

I2C & I2CI Motor-Connected Pumps Parts List

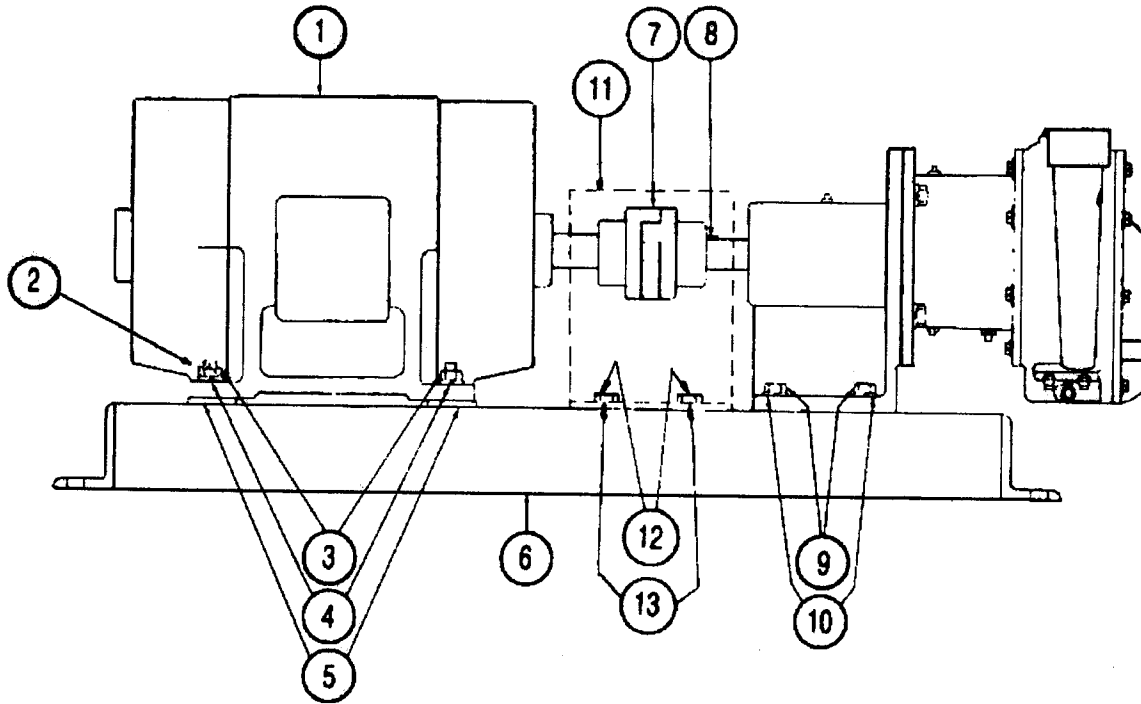

Ref. No.	Part No.	Description
1	18895A000	Motor - 5 HP, 230V, 60 Hz, 1 PH, ODP, 184T Frame
1	18897A000	Motor - 5 HP, 230/460V, 60 Hz, 3 PH, ODP, 182T Frame
1	24701A029	Motor - 5 HP, 230/460V, 60 Hz, 3 PH, TEFC, 184T Frame
1	24700A003	Motor - 7-1/2 HP, 230V, 60 Hz, 1 PH, ODP, 213T Frame
1	18899A000	Motor - 7-1/2 HP, 230/460V, 60 Hz, 3 PH, ODP, 184T Frame
1	24701A031	Motor - 7-1/2 HP, 230/460V, 60 Hz, 3 PH, TEFC, 213T Frame
1	24700A004	Motor - 10 HP, 230V, 60 Hz, 1 PH, ODP, 215T Frame
1	18901A000	Motor - 10 HP, 230/460V, 60 Hz, 3 PH, ODP, 213T Frame
1	21180A073	Motor - 10 HP, 230/460V, 60 Hz, 3 PH, TEFC, 215T Frame
1	18903A000	Motor - 15 HP, 230/460V, 60 Hz, 3 PH, ODP, 215T Frame
1	21180A068	Motor - 15 HP, 230/460V, 60 Hz, 3 PH, TEFC, 254T Frame
1	18905A000	Motor - 20 HP, 230/460V, 60 Hz, 3 PH, ODP, 254T Frame
1	21180A067	Motor - 20 HP, 230/460V, 60 Hz, 3 PH, TEFC, 256T Frame
2	05659A071	Stud, 3/8-16 UNC x 3-1/2 Lg. - 4 Req'd on 182T/184T Frame Units
2	05659A074	Stud, 3/8-16 UNC x 3-1/4 Lg. - 4 Req'd on 213T/215T Frame Units
2	05659A043	Stud, 1/2-13 UNC x 2-1/4 Lg. - 4 Req'd on 254T/256T Frame Units
3	19109A016	Nut, 3/8-16 UNC - 4 Req'd. on 182T, 184T, 213T, 215T Frame Units
3	19109A033	Nut, 1/2-13 UNC - 4 Req'd. on 254T, 256T Frame Units
4	05454A007	Washer, 3/8" Lock - 4 Req'd. on 182T, 184T, 213T, 215T Frame Units
4	05454A004	Washer, 1/2" Lock - 4 Req'd. on 254T, 256T Frame Units

Ref. No.	Part No.	Description
5	12924A004	Spacer, 2" thick - 4 Req'd. on 182T, 184T Frame Units
5	12924A007	Spacer, 1-1/4" thick - 4 Req'd. on 213T, 215T Frame Units
5	12924A005	Spacer, 1/4" thick - 4 Req'd. on 254T, 256T Frame Units
6	09938C101	Baseplate - 182T Frame Units
6	09938C111	Baseplate - 184T Frame Units
6	09939C071	Baseplate - 213T Frame Units
6	09939C081	Baseplate - 215T Frame Units
6	09939C091	Baseplate - 254T Frame Units
6	09939C998	Baseplate - 256T Frame Units
7	09950A005	Coupling, 5 & 7-1/2 HP Units w/182T & 184T Frames
7	09950A013	Coupling, 7-1/2 & 10 HP Units w/213T & 215T Frames
7	09950A016	Coupling, 15 HP Units w/215T Frames
7	09950A020	Coupling, 15 & 20 HP Units w/254T & 256T Frames - For Coupling Components see Section 1800, Page 204
8	05818A003	Key, 1/4 Sq. x 1-1/2 Lg.
9	19103A006	Screw, 1/2-13 UNC x 1-1/2 Lg. - 4 Req'd.
10	05454A004	Washer, 1/2" Lock - 4 Req'd.
11	20960B000	Guard
12	19099A005	Screw, 1/2-20 UNC x 5/8" Lg. - 4 Req'd.
13	05454A001	Washer, 1/4" Lock - 4 Req'd.

**MYERS/APLEX
LIMITED WARRANTY
INDUSTRIAL PRODUCTS
CENTRIFUGAL AND RECIPROCATING PUMPS**

MYERS/APLEX warrants that its products are free from defects in material and workmanship for a period of twelve (12) months from the date of purchase or eighteen (18) months from the date of manufacture.

During the warranty period and subject to the conditions hereinafter set forth, **MYERS/APLEX**, will repair or replace to the original user or consumer parts which prove defective due to defective materials or workmanship of **MYERS/APLEX**. Contact your nearest authorized **MYERS/APLEX** distributor or **MYERS/APLEX** for warranty service. At all times, **MYERS/APLEX** shall have and possess the sole right and option to determine whether to repair or replace defective equipment, parts or components..

WARRANTY EXCEPTIONS: Seals, piston cups, packing, plungers, liners, valves are covered for a period of ninety (90) days for ambient temperature water service. All other applications are for a period of thirty (30) days unless specific written guarantee for that specific application is made by **MYERS/APLEX**. All engines, motors, auxiliary equipment are warranted only to the extent of the warranty given by the respective manufacturer.

LABOR, ETC. COSTS: **MYERS/APLEX** shall IN NO EVENT be responsible or liable for the cost of field labor or other charges incurred by any customer in removing and/or reaffixing any **MYERS/APLEX** product, part or component thereof.

THIS WARRANTY WILL NOT APPLY: (a) to defects or malfunctions resulting from failure to properly install, operate or maintain the unit in accordance with printed instructions provided; (b) to failures resulting from abuse, accident or negligence; (c) to normal maintenance services and the parts used in connection with such service; (d) to units which are not installed in accordance with applicable local codes, ordinances and good trade practices; or (e) if the unit is moved from its original installation location and (f) unit is used for purposes other than for what it was designed and manufactured.

RETURN OR REPLACED COMPONENTS: any item to be replaced under this Warranty must be returned to **MYERS/APLEX** in Ashland, Ohio, or such other place as **MYERS/APLEX** may designate, freight prepaid.

PRODUCT IMPROVEMENTS: **MYERS/APLEX** reserves the right to change or improve its products or any portions thereof without being obligated to provide such a change or improvement for units sold and/or shipped prior to such a change or improvement.

WARRANTY EXCLUSIONS: **MYERS/APLEX** MAKES NO EXPRESS OR IMPLIED WARRANTIES WHICH EXTEND BEYOND THE DESCRIPTION ON THE FACE HEREOF. **MYERS/APLEX** SPECIFICALLY DISCLAIMS THE IMPLIED WARRANTIES OF MERCHANTABILITY AND FITNESS FOR ANY PARTICULAR PURPOSE.

Some states do not permit some or all of the above warranty limitations and, therefore, such limitations may not apply to you. No warranties or representations at any time made by any representatives of Myers/Aplex shall vary or expand the provision hereof.

LIABILITY LIMITATION: IN NO EVENT SHALL **MYERS/APLEX** BE LIABLE OR RESPONSIBLE FOR CONSEQUENTIAL, INCIDENTAL OR SPECIAL DAMAGES RESULTING FROM OR RELATED IN ANY MANNER TO ANY **MYERS/APLEX** PRODUCT OR PARTS THEREOF. PERSONAL INJURY AND/OR PROPERTY DAMAGE MAY RESULT FROM IMPROPER INSTALLATION. **MYERS/APLEX** DISCLAIMS ALL LIABILITY, INCLUDING LIABILITY UNDER THIS WARRANTY, FOR IMPROPER INSTALLATION -- **MYERS/APLEX** RECOMMENDS INSTALLATION BY PROFESSIONALS.

Some states do not allow the exclusion or limitation of incidental or consequential damages, so the above limitation or exclusion may not apply to you.

This Warranty gives you specific legal rights and you may also have other rights which vary from state to state.

In the absence of suitable proof of this purchase date, the effective date of this warranty will be based upon the date of manufacture.



1101 Myers Parkway, Ashland, Ohio 44805-1969
419/289-1144, FAX: 419/289-6658, TLX: 98-7443

TERMS & CONDITIONS OF SALE

PRICING AND SALES CONDITIONS COVERING MYERS EQUIPMENT

F. E. Myers herein referred to as the "Company," publishes its price lists and/or product catalogues and transmits the same to its distributors, dealers, sales representative and others (any such party being herein referred to as the "Buyer") in anticipation of their placing orders for equipment of the Company's manufacture as described in and/or covered by said product catalogues and price lists. BY SUBMITTING A WRITTEN OR TELEPHONE ORDER ANY BUYER WILL INDICATE ITS AGREEMENT TO THE "STANDARD CONDITIONS OF SALE OF MYERS EQUIPMENT" SET FORTH BELOW. ANY DIFFERENT OR ADDITIONAL TERM PROPOSED BY BUYER IS HEREBY OBJECTED TO. Subject to the "Standard Conditions of Sale of Myers Equipment" hereinbelow set forth, the Company offers to sell said equipment to any Buyer, provided that the placing of an order with the Company shall constitute the acceptance of all said Standard Conditions of Sale and any inconsistent or additional terms contained in a Buyer's order shall be considered as rejected by the Company unless expressly accepted in writing by the Company within ten (10) days of its receipt of such order.

STANDARD CONDITIONS OF SALE OF MYERS EQUIPMENT

ACCEPTANCE AND PAYMENT: The Company shall have the right to reject and refuse to process any order for any reason whatsoever, including, without limiting the generality of the foregoing, improper or inadequate credit qualifications or any prior failure of the Buyer to comply with any agreement with the Company.

Any portion of the price which is not paid in accordance with applicable payment terms shall bear interest, to be paid by the Buyer, at a rate of one and one-half percent (1-1/2%) per month, unless an applicable law limits the accrual of interest on such past due balance to a lesser rate, in which event interest shall accrue at such lesser rate.

Unless instructed otherwise, the Company shall be permitted to apply payments received against outstanding invoices and/or interest charges at its sole option and discretion.

PRICES AND TAXES: Any prices stated herein or elsewhere as applying to the equipment to be purchased shall be adjusted at the time of shipment in accordance with the Company's price schedule then in effect. Unless otherwise stated herein, prices quoted are F.O.B., Ashland, Ohio. Unless otherwise agreed by the Company in writing, the amount of any local State or Federal tax levied after the date hereof on the equipment referred to herein shall be paid by and remain the sole responsibility of the Buyer.

DELIVERY: Any dates or schedules which may be specified for the delivery of the equipment covered hereby have been stated only approximately and are estimated from the date of receipt of Buyer's order, with complete drawings, specifications, designs, sample and other information reasonably requested by the Company in order to proceed with the design and manufacture of the equipment and the Company shall not incur any liability, either direct or indirect, nor shall any order be cancelled, because or as a result of any delays in meeting such dates or schedules.

FORCE MAJEURE: The Company shall not be responsible or liable for any delays or failures in manufacture or delivery due to any cause or condition beyond the control of the Company, including, without limiting the generality of the foregoing, strikes or other labor difficulties, fire, floods, inability to secure transportation facilities, actions of the elements, shortage of materials or equipment, riots or other civil commotion, and war.

LAWS, ORDINANCES AND REGULATIONS: The Company shall utilize reasonable efforts to cause the equipment to comply with its interpretation of federal safety, health and environmental regulations and insurance codes of a national scope. However, the Company shall not be responsible for compliance by the equipment with local interpretations of such federal regulations or insurance codes, nor with any local laws, ordinances codes and/or regulations which may at any time be in effect at any location where the equipment is to be installed or utilized unless such responsibility shall be expressly assumed by the Company in writing.

CHANGES IN DETAIL OF DESIGN: The Company shall be entitled to make any and all changes in details of design, construction or arrangement of the equipment as the Company in its sole discretion determines will constitute an improvement upon the equipment or any specifications or designs previously furnished to the Buyer.

WARRANTY: The Company will honor its standard warranties covering the equipment for the period of time stated in its warranty policies, provided the equipment shall have been properly installed, maintained and utilized during the warranty period, provided, further, that the Company's warranties shall extend only to the original purchaser from the Company or from the Company's authorized Dealer, and provided, finally, that the Company shall in no event be responsible for the cost of field labor or other charges incurred by Buyer in removing and/or reaffixing any portion of the equipment to be returned to the Company for repair or replacement.

EXCLUSION OF OTHER WARRANTIES: EXCEPT FOR EXPRESS WARRANTIES AS DESCRIBED ABOVE, THERE ARE NO WARRANTIES INCLUDING ANY IMPLIED WARRANTIES OF MERCHANTABILITY OF FITNESS FOR ANY PARTICULAR PURPOSE, WHICH EXTEND BEYOND THE DESCRIPTION OF THE EQUIPMENT ON THE FACE HEREOF. NO WARRANTIES OR REPRESENTATIONS AT ANY TIME OF THE COMPANY SHALL BE EFFECTIVE TO VARY OR EXPAND THE ABOVE-REFERENCED EXPRESS WARRANTIES OR ANY OTHER TERMS HEREOF.

LIABILITY LIMITATIONS: In no event shall the Company be liable to the Buyer or to any third party for consequential, incidental or special damages resulting from or in any manner related to the equipment, its design, use, or inability to use the same, including, without limitation, damages arising out of or in any manner relating to the delivery or operation of the equipment or any delay with respect to its delivery or operation, it being understood that the sole and exclusive remedy of the Buyer or any third party shall be the repair, correction or replacement of defective equipment pursuant to the "WARRANTY" provisions hereinabove contained. Should the equipment prove so defective however, as to preclude the remedying of warranted defects by repair or replacement, the Buyer's sole and exclusive remedy shall be the refund of the purchase price upon its return of the equipment to the Company.

CANCELLATION: An order for other than standard equipment included within the Company's published catalogs may be cancelled in whole or in part by the Buyer only upon the payment to the Company by the Buyer, as a cancellation charge, of an amount equal to not less than the sum of any and all material, labor, shop and administrative overhead costs previously or thereafter incurred by the Company in connection with such order, or part thereof, cancelled, including without limitation the cost of all engineering work, work in process, raw materials, supplies and all commitments made by the Company in connection with the order, plus a reasonable profit based upon the total amount of such costs. Upon the receipt of written notice from the Buyer of its desire to cancel an order, or part thereof, the Company shall utilize reasonable efforts with respect to such order or part thereof, in order to limit the amount of additional costs incurred, provided, however, that any and all work which can be completed within a period of thirty (30) days from date of receipt of notification may, at the sole option of the Company, be completed and Buyer shall pay for the same in full, in its sole discretion, the Company may reduce the amount of the aforesaid cancellation charge in the event and to the extent that any work and/or materials performed by the Company in connection with the order, or part thereof, cancelled can be put into profitable use by the Company.

INFRINGEMENT: With respect to the equipment covered hereby, the Company shall hold the Buyer harmless to the extent of any rightful claim under and U.S. patents concerning such equipment as delivered, provided that Buyer promptly notifies the Company of any charge of infringement of the institution of any litigation alleging infringement and that the Buyer turn over to the Company full control of the disposition of any such charge or litigation including the right to defend, settle, or otherwise compromise any such third party claim. In case such equipment, or any part thereof, is in such suit held to constitute infringement and the use of said equipment or part is enjoined, the Company shall at its own expense and at its option (a) procure for the purchaser the right to continue using said equipment, (b) replace said equipment with non-infringing equipment, (c) modify said equipment so that it becomes non-infringing, or (d) remove said equipment and refund the purchase price and the transportation and installation costs thereof. In the event that the equipment encompasses any feature, construction, or design at Buyer's request other than the normally offered by the Company, or should any additions, changes or modifications be made by the Buyer to the Company's equipment, Buyer agrees to hold the Company harmless against any claim of infringement of any U.S. patent relating thereto which may be asserted against the Company by any third party.

APPLICABLE LAW: The terms and conditions applicable to the transaction provided for herein shall be determined and construed in accordance with and shall be governed by, the laws of the State of Ohio and Buyer and the Company agree to submit to the jurisdiction of the appropriate State and Federal Court within Ohio for purchase of resolving any dispute or claim arising in connection with said transaction.