



**Myers**<sup>®</sup>

**Pentair Water**

293 Wright Street, Delavan, WI 53115

Phone: 888-987-8677

Fax: 800-426-9446

Web Site: femyers.com

OWNER'S MANUAL

## **Submersible Sump, Sewage, Effluent Pumps**

---

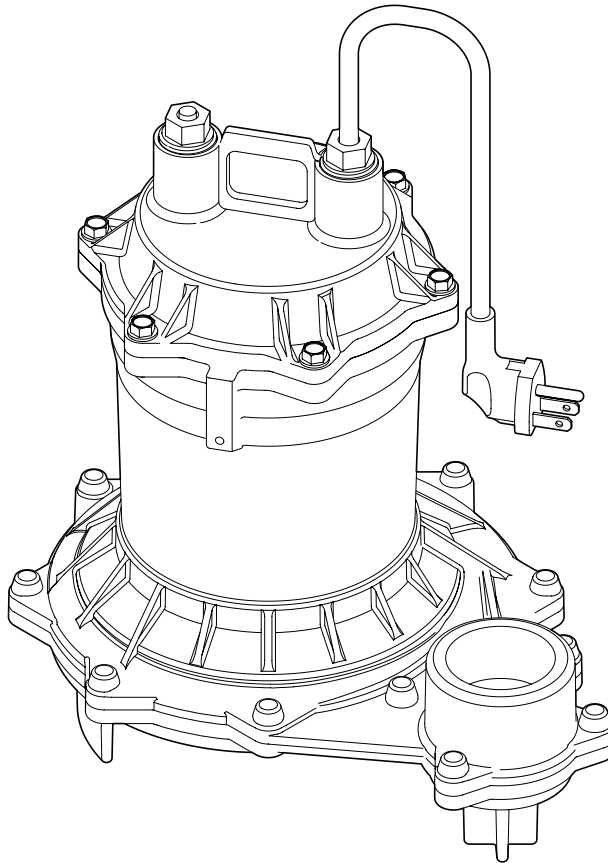

### **ME40 / ME40AG Series**

#### **Installation/Operation/Repair Parts**

*For further operating, installation, or  
Maintenance assistance:*

**Call 1-888-987-8677**

## Important Safety Instructions

SAVE THESE INSTRUCTIONS - This manual contains important instructions that should be followed during installation, operation, and maintenance of the product. Save this manual for future reference.

**▲** This is the safety alert symbol. When you see this symbol on your pump or in this manual, look for one of the following signal words and be alert to the potential for personal injury!

**▲ DANGER** indicates a hazard which, if not avoided, will result in death or serious injury.

**▲ WARNING** indicates a hazard which, if not avoided, could result in death or serious injury.

**▲ CAUTION** indicates a hazard which, if not avoided, could result in minor or moderate injury.

**NOTICE** addresses practices not related to personal injury.

Keep safety labels in good condition. Replace missing or damaged safety labels.

1. Read these rules and instructions carefully. Failure to follow them could cause serious bodily injury and/or property damage.
2. Check your local codes before installing. You must comply with their rules.
3. Vent sewage or septic tank according to local codes.
4. Do not install pump in any location classified as hazardous by National Electrical Code, ANSI/NFPA 80-1984 or the Canadian Electrical Code.

**▲ WARNING Risk of electric shock.** Can shock, burn or kill. During operation the pump is in water. To avoid fatal shocks, proceed as follows if pump needs servicing:

Do not smoke or use devices that can generate sparks in a septic (gaseous) environment.

- 5A. Disconnect power to outlet box before unplugging pump.
- 5B. Take extreme care when changing fuses. Do not stand in water or put your finger in the fuse socket.
- 5C. Do not modify the cord and plug. When using the cord and plug, plug into a grounded outlet only. When wiring to a system control, connect the pump ground lead to the system ground.
6. Be sure that construction and access to septic sumps conform with all OSHA requirements.
7. **▲ CAUTION Risk of burns.** Do not run the pump dry. Dry running can overheat the pump, (causing burns to anyone handling it) and will void the warranty.
8. **▲ CAUTION Risk of burns.** The pump normally runs hot. To avoid burns when servicing pump, allow it to cool for 20 minutes after shutdown before handling.
9. The pump is permanently lubricated. No oiling or greasing is required in normal operation.

When used in effluent dosing or S.T.E.P. applications, the pump must be installed in a separate tank or compartment at the discharge side of the septic tank.

**NOTICE** Never install the pump in the main tank where sludge collects. Do not use the pump for raw sewage.

## Description

Myers ME40 Series Pumps are single seal units, automatic or manual, designed for use in effluent dosing, Septic Tank Effluent Pumping (S.T.E.P.) or normal sump and general dewatering applications where higher pressure is required. Impellers are enclosed two-vane type to handle 3/4" spherical solids and are made of engineered thermoplastic. All pumps have a 1-1/2" NPT discharge tapping. Each pump is packaged separately in a carton marked with a catalog number and Myers engineering number.

**NOTICE** Do not overtighten discharge pipe into pump plastic discharge fitting.

**NOTICE** This unit is not designed for applications involving salt water or brine! Use with salt water or brine will void warranty.

**NOTICE** This pump is not approved for, and should not be used in, swimming pools or fountains.

### ME40

The ME40 Series pumps are available in 115 volt or 230 volt, single phase, 4/10 HP motors. All units are single seal only, available in automatic or manual with either 10' or 20' power cords. All power cords have either 115 volt or 230 volt grounded plugs.

### ME40AG

The ME40AG Series pumps are single seal units designed for use in continuous run agricultural evaporative cooling applications. They will run continuously in elevated temperatures with clean sump water.

The wetted pump components are the same as already described for the ME40 series.

## Specifications

Model	HP	V	Ph	Cord Lgth.	Type	
ME40A-11	4/10	115	1	10'	Auto	
ME40M-11					Manual	
ME40AC-11				20'	Auto	
ME40MC-11					Manual	
ME40AC-21					Auto	
ME40MC-21					Manual	
ME40P-1		230		10'	Auto	
ME40PC-1						20'
ME40P-2						10'
ME40PC-2				20'		Manual
ME40AG-11						
ME40AG-21						

## Motor Type

The motors used in the ME40/ME40AG pumps are pressed into the cast iron housing and surrounded by dielectric oil for the greatest heat dissipation. The ME40 uses a shaded pole, 4/10 HP, 1550 RPM motor. The ME40AG uses a permanent split capacitor, 4/10 HP, 1625 RPM motor. Both units have Class A motor insulation, are available in single phase 115 or 230 volt with overload protection, and use a lower ball bearing - upper sleeve bearing. These pumps have no starting switches and do not require a control panel for simplex installation. All pumps have UL and CSA approval. Myers is a SSPMA-certified pump member.

## Air Locking

A sump pump is said to be air locked if air is trapped in the pump and it cannot get out, thus preventing the pump from operating.

The ME40/ME40AG pumps have a built-in air vent hole in the impeller chamber to let out trapped air. It is normal for liquid to spray out of this hole during operation. If this hole becomes plugged, the pump may air lock. As a secondary precaution a 1/8" hole should be drilled in the discharge pipe below the check valve. The check valve should be 12 to 18 inches above pump discharge. Do not put check valve directly into pump discharge opening.

## Level Controls

All pumps must use sealed level control switches for automatic operation. All automatic pumps have built-in level control float switches. The power cord has a ground pin that plugs into a grounded receptacle. The grounded receptacle cannot be used in the wet sump or basin due to danger of current leakage.

Manual pumps can be made automatic with MLC or MFLC controls with a series plug. Plug the MLC or MFLC series plug into a proper voltage grounded receptacle. Then plug the pump cord plug into the back of the switch cord series plug. The float control must be tethered a minimum 4" to pump or discharge pipe. Control must float free from pump and basin wall.

On all duplex units or simplex installations with additional options like high water alarm, the power cord plug must be cut off and wired into a control panel or into a sealed junction box if used in wet sump or basin. The AWS-1 control also acts as a sealed junction box for connecting power cord to pump cord.

**NOTICE** The ME40 sump/effluent pump can be easily changed from one style, automatic or manual, to the other by merely interchanging the plug ends of the float control with the manual plug. The ball float must be tethered with a cable clamp, as shown. Do not remove the motor cap.

ME40P pumps have a mechanical (mercury free) float switch with a 10' or 20' cord with a 115 volt or 230 volt piggyback plug with the switch mounted to the pump. Plug the switch cord plug into a proper voltage, properly grounded outlet and plug the power cord into the back of the switch cord and tape the cords to the discharge pipe every 12".

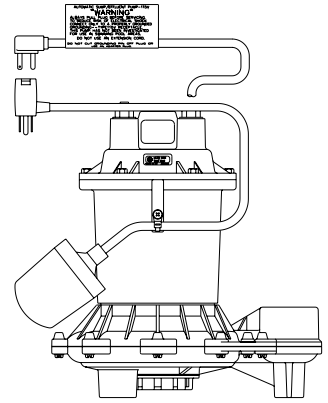

## Installation

**⚠ WARNING Risk of electric shock.** Can shock, burn or kill. Do not lift pump by the power cord. See *Cord Lift Warning* below.

**NOTICE** Install the pump on a hard, level surface (cement, asphalt, etc.). Never place the pump directly on earth, clay or gravel surfaces. Install the pump in a sump basin with a minimum diameter of 18" (46cm).

## Cord Lift Warning

**⚠ WARNING**



Risk of electrical shock.  
Can burn or kill.  
Do not lift pump by power cord.

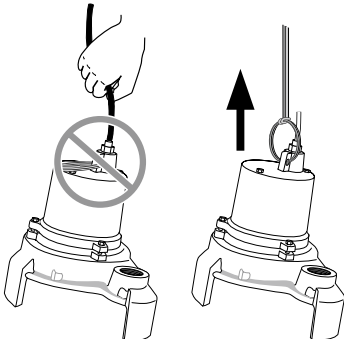

Typical pump shown

1. Attempting to lift or support pump by power cord can damage cord and cord connections.
2. Cord may pull apart, exposing bare wires with possibility of fire or electrical shock.
3. Lifting or supporting pump by power cord will void warranty.
4. Use lifting ring or handle on top of pump for all lifting/lowering of pump. Disconnect power to pump before doing any work on pump or attempting to remove pump from sump.

## Piping

Piping must not be smaller than pump discharge.

The pump is designed to operate partially or completely submerged in effluent liquids and pump semi-solid fluids up to 3/4" (51mm) in diameter.

When installed in an effluent system, the pipe must be capable of handling semi-solids of at least 3/4" (19mm) in diameter.

The rate of flow in the discharge pipe must keep any solids present in suspension in the fluid. To meet minimum flow requirements (2 feet per second in the discharge line), size the pipe as follows:

A Pipe Size Of:	Will Handle a Flow Rate Of:
1-1/2" (38mm)	12 GPM
2" (51mm)	21 GPM
2-1/2" (64mm)	30 GPM
3" (76mm)	48 GPM

In an effluent system use a 1-1/2" (38mm) check valve in pump discharge to prevent backflow of liquid into sump basin. The check valve should be a free flow valve that will easily pass solids. Be sure check valve installation complies with local codes.

Be sure that the float switch hangs freely. It should not be able to come in contact with the sides or bottom of the sump pit.

Make sure the sump pit is free of any debris that could obstruct the intake volute or switch.

Use plumbing materials that are approved by local building codes when connecting pipes between pump and sewer outlet.

**▲ WARNING Risk of explosion and hazardous gas.** Never enter pump chamber after sewage or effluent has been in basin. Sewage water can give off methane, hydrogen sulfide, and other gasses which are highly poisonous. For this reason, Myers recommends installing effluent pumps with a quick removal system. The quick removal system may be a union or quick-release coupling if the pipe or discharge hose is within reach from the surface, or a rail system type quick disconnect on deeper installations. See Figure 2 for a typical installation.

The dosing tank or pumping chamber must be constructed of corrosion resistant materials and must be capable of withstanding all anticipated internal and external loads. It also must not allow infiltration or exfiltration. The tank must have provisions for anti-buoyancy. Access holes or covers must be adequate size and be accessible from the surface to allow for installation and maintenance of the system. Access covers must be lockable or heavy enough to prevent easy access by unauthorized personnel. The pumping chamber holding capacity should be selected to allow for emergency conditions.

Test the pump installation by filling the sump basin with enough water to activate the pump and repeat this cycle until satisfied with pump operation.

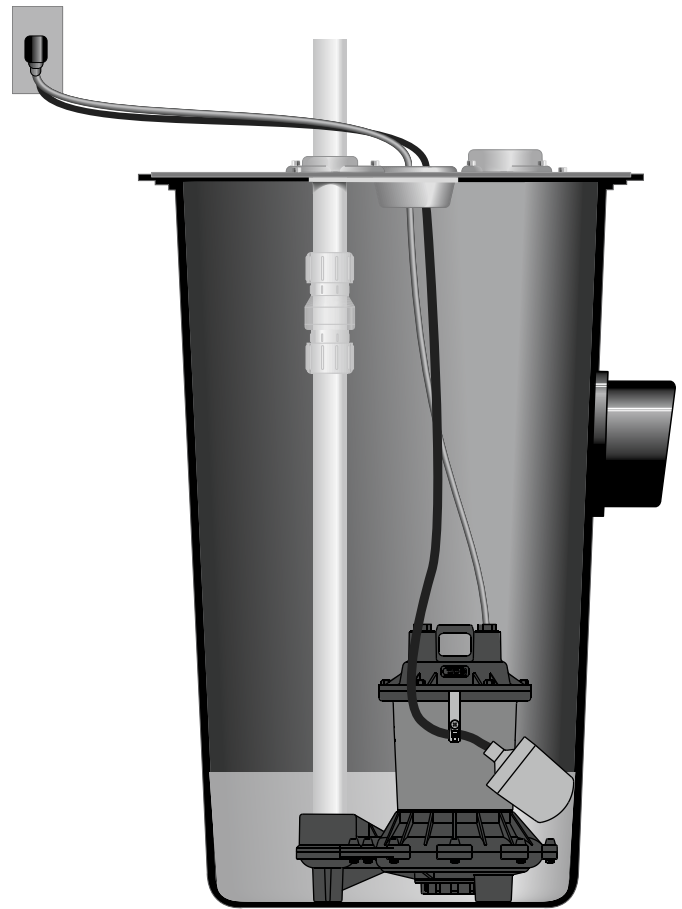

**Figure 2: ME40 Typical Installation**

**NOTICE** For critical indoor installations where additional high water protection is desired, install an audible alarm system in the sump pit. For outdoor installations, confer with your distributor.

Connect the power cord to a 3-prong grounded AC receptacle.

## Electrical

**▲ WARNING Risk of electric shock.** Can shock, burn or kill. When installing, operating, or servicing this pump, follow the safety instructions listed below.

1. DO NOT splice the electrical power cord.
2. DO NOT allow the plug on the end of the electrical cord to be submerged.
3. DO NOT use extension cords. They are a fire hazard and can reduce voltage sufficiently to prevent pumping and/or damage motor.
4. DO NOT handle or service the pump while it is connected to the power supply.
5. DO NOT remove the grounding prong from the plug or modify the plug. To protect against electrical shock, the power cord is a three-wire conductor and includes a 3-prong grounded plug. Plug the pump into a 3-wire, grounded, grounding-type receptacle. Connect the pump according to the NEC or CEC and local codes.
6. DO NOT connect to GFCI outlet as premature failure of motor could occur.

## Screen

ME40AG pumps have a suction screen included in the packaging. To secure the screen in place use two screws (provided). Screen installation, maintenance, and cleaning is the responsibility of the pump owner.

## Operation

**⚠ WARNING Risk of fire and explosion.** Can cause severe injury, property damage or death. Do not use in explosive atmospheres. Pump water only with this pump.

**NOTICE** Do not allow the pump to run in a dry sump. It will void the warranty and may damage the pump.

An automatic overload protector in the motor will protect the motor from burning out due to overheating/overloading. When the motor cools down, the overload protector will automatically reset and start the motor.

If the overload trips frequently, check for the cause. It could be a stuck impeller, wrong/low voltage, or an electrical failure in the motor. If an electrical failure in the motor is suspected, have it serviced by a competent repairman.

The pump is permanently lubricated. No oiling or greasing is required.

Cycle the pump at least once every month to be sure that the system is working satisfactorily.

**NOTICE** Any of the following will void the pump warranty:

- Pumping materials other than those the pump was designed to pump or continuously pumping water hotter than 120°F (49°C).
- Splicing a power cord or switch cord.
- Removing the cord tag from the cord.

Model	HP	Speed	V	Ph	Winding Resistance in Ohms	Max. Amps	Locked Rotor Amps
ME40	4/10	1550	115	1	1.2	12.0	16.0
ME40			230		4.3	6.0	8.2
ME40AG		1650	115		2.0	8.0	17.6
ME40AG			230		9.1	4.0	8.8

### Motor Resistance Chart

### Product Dimensions

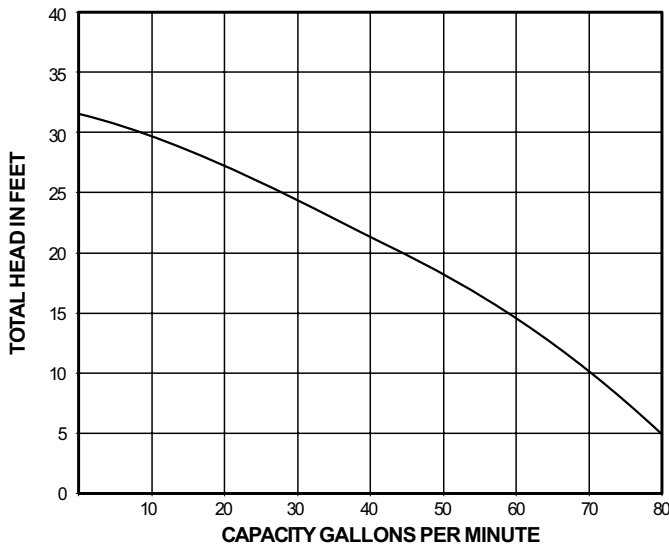
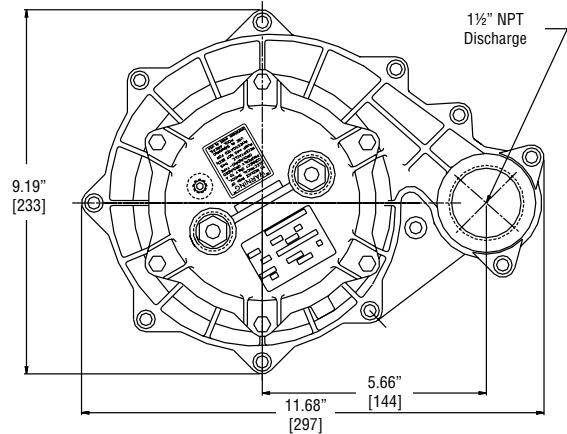
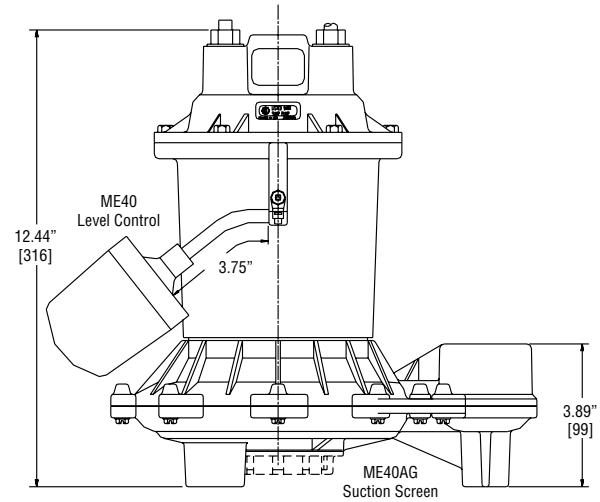

ME40 Performance Curve

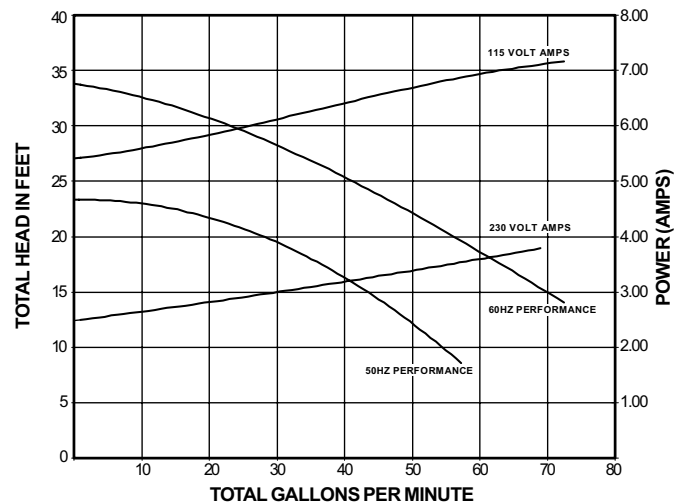

ME40AG Performance Curve

## Maintenance

### General

**▲WARNING** **Risk of electric shock.** Can shock, burn or kill. Before removing the pump from the basin for service, always disconnect electrical power to the pump and the control switch. Do not lift the pump by the power cord. See the *Cord Lift Warning*.

### Disinfect the Pump

Place the pump in an area where it can be cleaned thoroughly. Remove all scale and deposits on the pump.

**▲WARNING** **Risk of infection.** Submerge the complete pump in a disinfectant solution (dilute chlorine bleach) for at least one hour before disassembling the pump.

The pump motor housing contains a special lubricating oil which should be kept clean and free of water at all times.

### Replace Power Cord Or Automatic Control Float

**▲CAUTION** **Possible contamination.** Wear rubber gloves when working on switch. Dispose of old switch according to ordinances.

1. Use a wrench to loosen and remove thermoplastic nut from the cap socket. Use your fingers to pull and wiggle the cord end connector from the socket.
2. To replace either the power cord or automatic control float, align the half circle notch on the cord end connector with the half circle key in the socket. Press the connector into the socket all the way.
3. Slide the thermoplastic washer onto the top of the cord end connector.
4. Screw the thermoplastic nut into the socket. Tighten the nut snugly, but do not over tighten. The nut may be tightened a little more after the connector has set over a period of time.
5. If replacing automatic control float be sure to tether float approximately 3-5/8".

### Replace Shaft Seal Only

1. Remove the six screws from top thermoplastic cap and bump cap with plastic hammer to loosen.
2. Lay the cap back, do not disconnect wires from the cap. Pour all the oil from the pump. If the old seal failed there may be water in the oil and old oil should be discarded.
3. Remove the eleven machine screws holding the volute halves together. Separate lower half volute from the upper half by using a rubber hammer and/or prying lightly with a screwdriver.
4. Lay pump on its side. Place a flat screwdriver in the slot in the bottom of the shaft and turn the impeller counterclockwise to remove it from the shaft. A blow from a rubber hammer may be necessary to loosen the impeller.

5. Remove the rotating portion (carbon) of the seal with pliers. Pry out the stationary portion (ceramic) with a pair of slotted screwdrivers to remove from volute casing. Discard the old seal assembly parts.

**NOTICE** Never use old seal parts - rebuild pump with new seal assembly ONLY.

6. Thoroughly clean the shaft and volute casing with a clean cloth. If the drained oil showed signs of water, then the motor should be air dried for several days to remove any remaining moisture.
7. Remove the seal from the package being careful not to touch the carbon or ceramic faces with fingers or anything dirty. Add a film of oil to the perimeter of the rubber cup holding the ceramic and insert into the motor housing. Use a push tool the same size as the ceramic face (a short piece of PVC pipe works well).
8. With a clean dry cloth, wipe away any smudging or oil from the seal faces. Add a film of new oil onto the motor shaft. With the carbon facing towards the ceramic, slide the rotating part onto the motor shaft. Push it on far enough to attach impeller.
9. Screw the impeller clockwise onto the shaft using a screwdriver to hold the shaft from turning and tighten impeller. Use a thread lock compound on shaft threads.
10. Place pump upright on top of lower volute half. Be sure mating parts are together and reassemble the eleven machine screws and tighten.
11. Check that the impeller turns freely.
12. Replace oil in motor housing using only refined paraffinic transformer oil, <sup>1</sup>Shellflex™ 2210 or equivalent. The oil should be about 1/2" above the upper surface of the bearing plate.  
<sup>1</sup> Shell Oil Company, Texas
13. Reinstall the top thermoplastic cap, making sure the o-ring is in position on the cap. Tighten the top six screws snug, but do not overtighten.
14. Plug pump into receptacle to test operation. Pump must run quiet and free of vibration.

### Replace Motor Stator Housing Assembly And Seal

1. Stator assembly includes housing, stator, rotor with shaft, thrust washers and metal bearing plate. (See *Repair Parts*)
2. Remove the six screws from top thermoplastic cap and bump cap with plastic hammer to loosen.
3. Disconnect the four motor lead wires from the cap pin terminals and remove cap. Pour all the oil from the pump.
4. Remove the eleven machine screws holding the volute halves together. Separate lower half volute from the upper half by using a rubber hammer and/or prying lightly with a screwdriver.

5. Lay pump on its side. Place a flat screwdriver in the slot in the bottom of the shaft and turn the impeller counterclockwise to remove it from the shaft. A blow from a rubber hammer may be necessary to loosen the impeller. Discard old seal parts.
6. Remove the four flat head screws holding the upper half of volute to housing. Note position of discharge in relation to switch clamp.
7. To assemble the new ceramic seal seat into your new stator housing assembly, clean the seat cavity thoroughly and follow instructions in *Replace Shaft Seal Only*.
8. Assemble the upper half of the volute to housing with the four flat head screws. Position discharge the same as before in relation to switch clamp.
9. Make sure the shaft surface is clean and lightly oiled. Press by hand the rotating half of the shaft seal onto the shaft. Be sure the rotating carbon washer is positioned adjacent to the ceramic seat.
10. Screw the impeller clockwise onto the shaft using a screwdriver to hold the shaft from turning and tighten impeller. Use a thread sealant on shaft threads.
11. Place pump upright on top of lower volute half. Be sure mating parts are together and reassemble the eleven machine screws and tighten.
12. Check that the impeller turns freely.
13. Guide the four motor wires up through a common hole in the bearing plate and place the protective plastic tube over the four motor wires.
14. Position the o-ring into cap and reconnect the four motor wires as shown in wiring diagram. The two green ground wires connect to the pins nearest the 'G' marked on the cap.
15. Put oil in motor housing using only refined paraffinic transformer oil, Shellflex™ 2210 or equivalent. The oil should be about 1/2" above the upper surface of the bearing plate.
16. Reinstall the top thermoplastic cap, making sure the o-ring is in position on the cap. Tighten the top six screws snug, but do not overtighten.
17. Be sure the 1/8" NPT pipe plug is in the top cap.
18. Plug pump into receptacle to test operation. Pump must run quiet and free of vibration.

**NOTICE** When replacing top cap with a new one, be sure the jumper wire and pipe plug are in place. See *Wiring Diagram*. Tether level control to motor housing with float extended 3-5/8" to 4".

## Troubleshooting Chart

**⚠ WARNING Risk of cuts and possible unexpected starts.** If the power is on to the pump when thermal overload resets, the pump may start without warning. If you are working on the pump, you may get an electrical shock or the impeller may catch fingers or tools. Disconnect the power before servicing the pump.

A. Pump fails to operate:	1. Check to be sure that power cord is securely plugged into outlet or securely wired into controller or switch box.
	2. Check to be sure you have electrical power. Be sure that the piggyback plugs are tight.
	3. Check that liquid fluid level is high enough to activate switch or controller.
	4. Check to be sure that 1/8" (3 mm) vent hole in discharge pipe is not plugged.
	5. Check for blockage in pump inlet, impeller, check valve or discharge pipe.
	6. Disconnect the pump from the power source for a minimum of 30 minutes to allow the motor to cool and to protect yourself from sudden starts. See Warning above. Check for the cause of overheating. Pump is running dry because the float switch is caught up on something. Inlet pipe is plugged. Outlet pipe is plugged.
	7. Motor windings may be open. Take unit to authorized service center.
B. Pump fails to empty sump:	1. Be sure all valves in discharge pipe are fully open.
	2. Clean out discharge pipe and check valve.
	3. Check for blockage in pump inlet or impeller.
	4. Pump not sized properly. A higher capacity pump may be required.
C. Pump will not shut off:	1. Check switch or controller automatic floats for proper operation and location. See installation instructions for switch/controller.
	2. If pump is completely inoperative or continues to malfunction, consult your local serviceman.

# Typical Section Drawing For ME40 Series Shaded Pole Motor

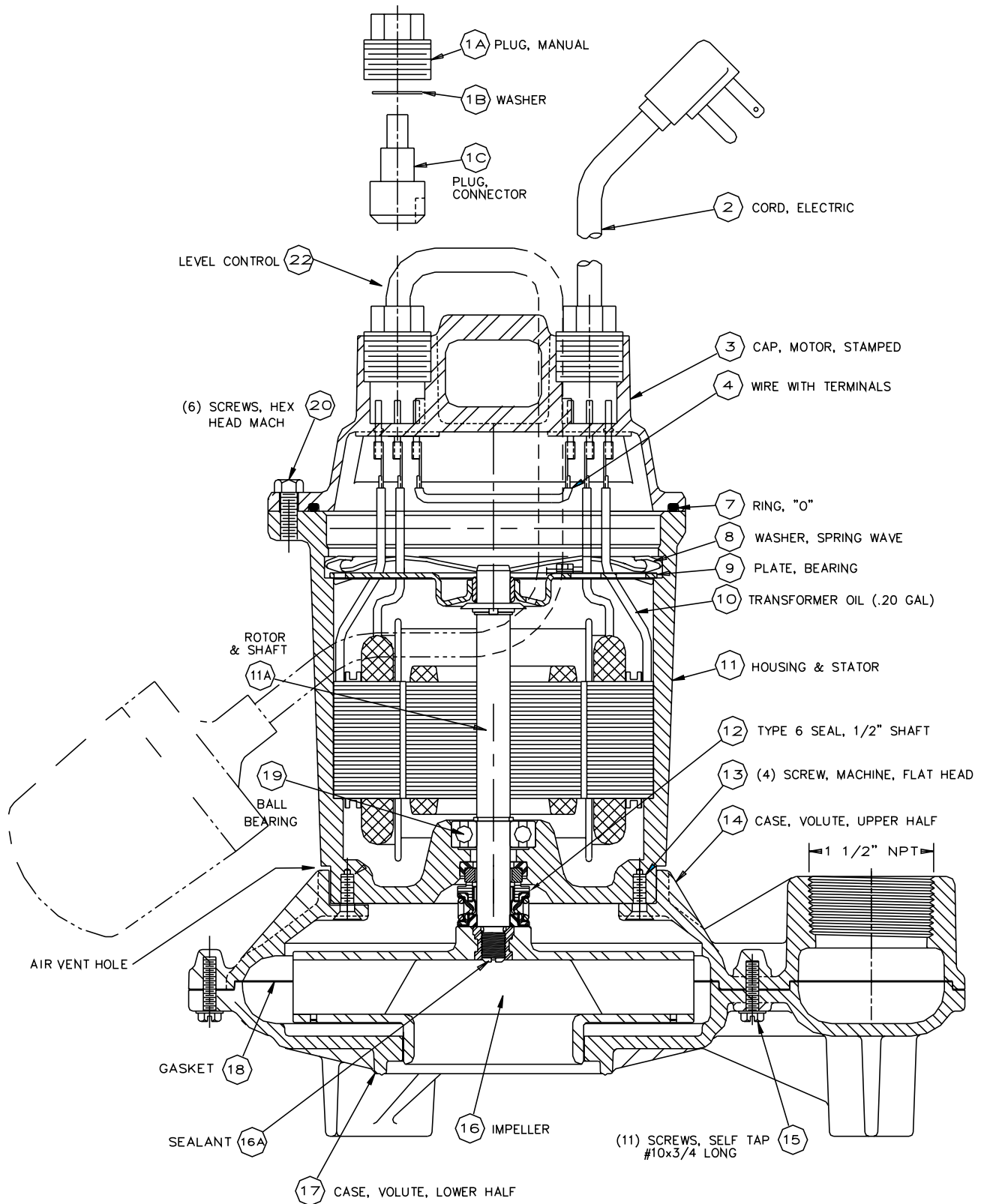

# Typical Section Drawing For ME40AG Series PSC Motor

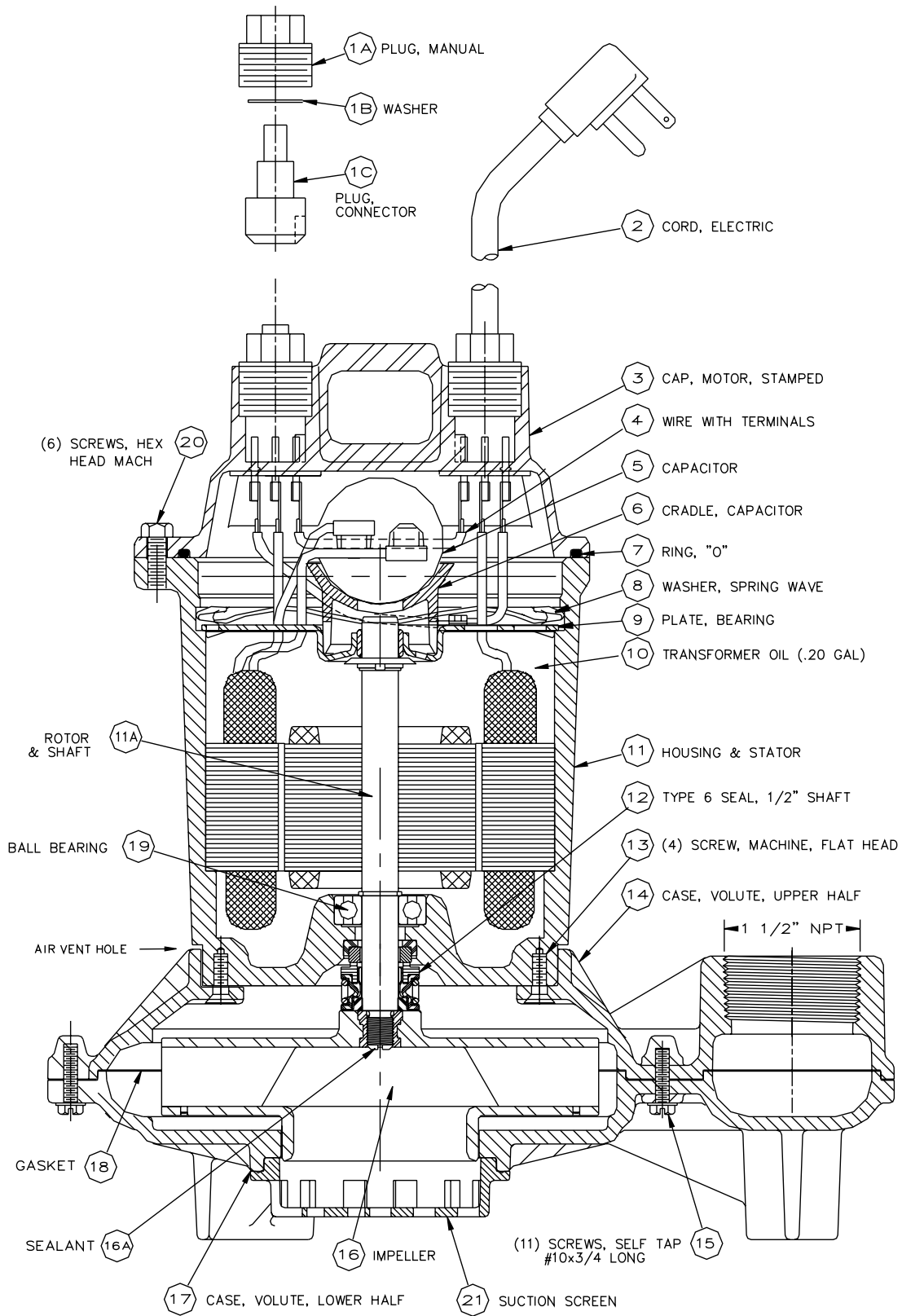

## Repair Parts

Ref.	Description	Qty.	Part Number
1A	Plug, nut (manual only)	1	24448A000
1B	Washer (manual only)	1	05030A213
1C	Plug, connector (manual only)	1	24449A000
2	Cord, electric	1	See Chart
3	Cap, motor (not stamped)	1	24431C000
4	Wire with terminals	1	09859A800
5	Capacitor (115 volt)	1	26446A000
	Capacitor (230 volt)	1	23290A000
6	Cradle, capacitor (230 volt)	1	26298B000
7	O-Ring, 5-1/2 x 5-1/4 x 1/8	1	05876A146
8	Washer, spring wave	1	19331A011
9	Plate, bearing	1	24661B000
10	Oil, transformer (1 gal.)	.2 gal.	11009A008
11	Housing, with rotor & stator	1	See Chart
	Stator only	1	See Chart
	Rotor & shaft, ME40	1	25309A000
	Rotor & shaft, ME40AG	1	26166B000
	Housing only	1	27313C000

Ref.	Description	Qty.	Part Number
12	Seal, shaft	1	21607A015
13	Screw, machine, flat head	4	07597A030
14	Case, volute, upper half	1	25306D000
15	Screws, self tap #10 x 3/4	11	05910A012
16	Impeller	1	25301B900
16A	Sealant	1	14550A001
17	Case, volute, lower half	1	25307D001
18	Gasket	1	25328C000
19	Ball bearing	1	000650241
20	Screws, hex head mach.	6	18475A003
21	Suction screen	1	25307A015
22	Level control	1	See Chart

## Chart

Model	Pump Type	Cord, Electric	Cord Length	Housing w/Rotor & Stator	Stator Only	Level Control
ME40A-11	Automatic	21628B017	10'	27313C010	21599B022	25798A550
ME40M-11	Manual	21628B027	10'	27313C010	21599B022	---
ME40AC-11	Automatic	21628B044	20'	27313C010	21599B022	25798A550
ME40MC-11	Manual	21628B044	20'	27313C010	21599B022	---
ME40AC-21	Automatic	21628B019	20'	27313C011	21599B023	25798A550
ME40MC-21	Manual	21628B019	20'	27313C011	21599B023	---
ME40P-1	Automatic	21628B041	10'	27313C010	21599B022	21813B130
ME40PC-1	Automatic	21628B044	20'	27313C010	21599B022	21813B131
ME40PC-2	Automatic	21628B019	20'	27313C011	21599B023	21813B133
ME40AG-11	Manual	21628B044	20'	27313C012	26165B000	---
ME40AG-21	Manual	21628B043	20'	27313C013	26165B001	---

SWITCH SIDE FOR AUTOMATIC  
& PLUG SIDE FOR MANUAL

POWER CORD SIDE  
FOR AUTOMATIC  
& MANUAL

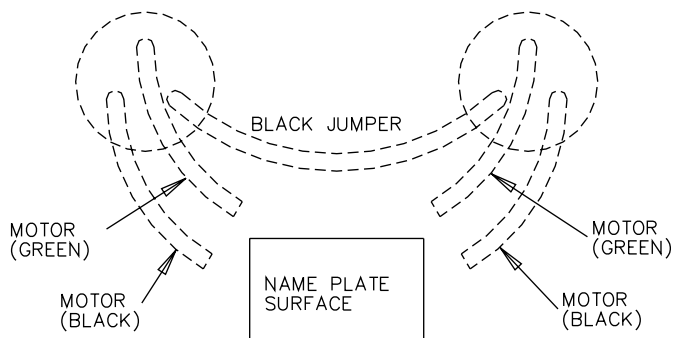

### Wiring Diagram

# Warranty

## Limited Warranty

F.E. MYERS warrants to the original consumer purchaser ("Purchaser" or "You") of the products listed below, that they will be free from defects in material and workmanship for the Warranty Period shown below.

Product	Warranty Period
Jet pumps, small centrifugal pumps, submersible pumps and related accessories	<i>whichever occurs first:</i> 12 months from date of original installation, or 18 months from date of manufacture
Fibrewound Tanks	5 years from date of original installation
Steel Pressure Tanks	5 years from date of original installation
Sump/Sewage/Effluent Products	12 months from date of original installation, or 24 months from date of manufacture

Our warranty will not apply to any product that, in our sole judgement, has been subject to negligence, misapplication, improper installation, or improper maintenance. Without limiting the foregoing, operating a three phase motor with single phase power through a phase converter will void the warranty. Note also that three phase motors must be protected by three-leg, ambient compensated, extra-quick trip overload relays of the recommended size or the warranty is void.

Your only remedy, and F.E. MYERS's only duty, is that F.E. MYERS repair or replace defective products (at F.E. MYERS's choice). You must pay all labor and shipping charges associated with this warranty and must request warranty service through the installing dealer as soon as a problem is discovered. No request for service will be accepted if received after the Warranty Period has expired. This warranty is not transferable.

F.E. MYERS SHALL NOT BE LIABLE FOR ANY CONSEQUENTIAL, INCIDENTAL, OR CONTINGENT DAMAGES WHATSOEVER. THE FOREGOING LIMITED WARRANTIES ARE EXCLUSIVE AND IN LIEU OF ALL OTHER EXPRESS AND IMPLIED WARRANTIES, INCLUDING BUT NOT LIMITED TO IMPLIED WARRANTIES OF MERCHANTABILITY AND FITNESS FOR A PARTICULAR PURPOSE. THE FOREGOING LIMITED WARRANTIES SHALL NOT EXTEND BEYOND THE DURATION PROVIDED HEREIN.

Some states do not allow the exclusion or limitation of incidental or consequential damages or limitations on the duration of an implied warranty, so the above limitations or exclusions may not apply to You. This warranty gives You specific legal rights and You may also have other rights which vary from state to state.

This Limited Warranty is effective June 1, 2011 and replaces all undated warranties and warranties dated before June 1, 2011.

### **F.E. MYERS**

**293 Wright Street, Delavan, WI 53115**

**Phone: 888-987-8677 • Fax: 800-426-9446 • [www.femyers.com](http://www.femyers.com)**

**In Canada: P. O. Box 9138, 269 Trillium Dr., Kitchener, Ontario N2G 4WS**

**Phone: 519-748-5470 • Fax: 888-606-5484**

F. E. Myers, 293 Wright Street, Delavan, WI 53115  
888-987-8677 • FAX: 800-426-9446 • [www.femyers.com](http://www.femyers.com)

Myers (Canada), 269 Trillium Drive, Kitchener, Ontario N2G 4W5  
519-748-5470 • FAX: 888-606-5484