

Myers®

**3MW SERIES
Submersible Sewage Pumps
1750 & 3450 rpm Models
Safety Instructions,
Installation and Service Manual**

Single and double seal. Single and three phase power.

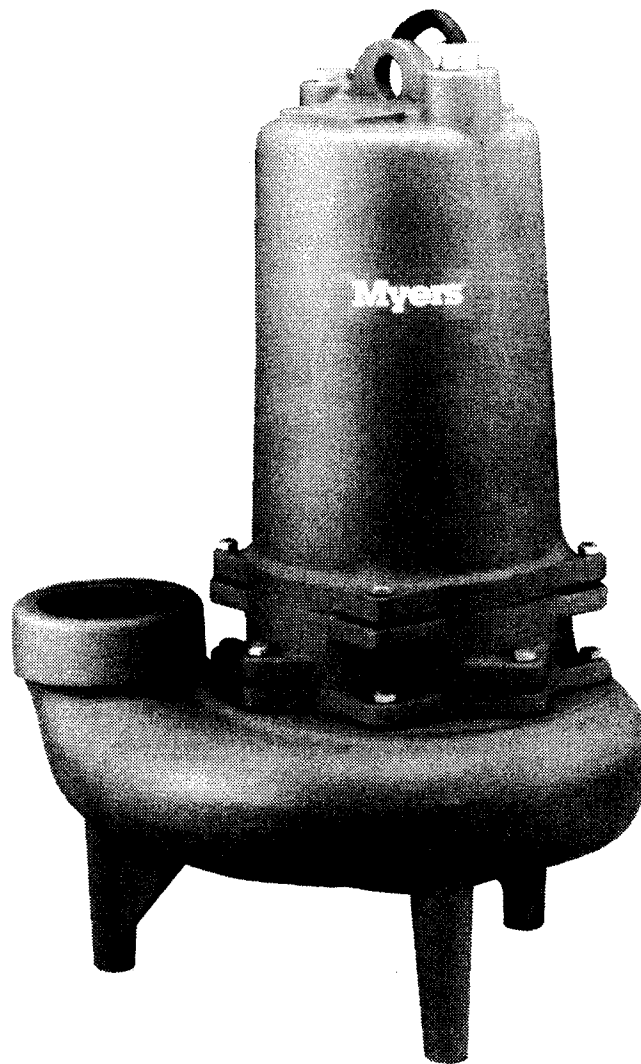

3MW PUMP

SAFETY WARNINGS

This manual contains important information for the safe use of this product. Read this manual completely before using this product and refer to it often for continued safe product use.

Failure to heed these symbols and follow the instructions in this manual may result in **severe bodily injury** or **death**, or **substantial property damage**.

DO NOT THROW AWAY OR LOSE THIS MANUAL.

Keep it in a safe place so that you may refer to it often.

- ⚠ **DO NOT** wear loose clothing that can become entangled in the impeller or other moving parts.
- ⚠ This pump is designed to handle materials which could cause illness or disease through direct exposure. Wear adequate protective clothing when working on the pump or piping.
- ⚠ To reduce risk of electrical shock, pump must be properly grounded in accordance with the National Electrical Code and all applicable state and local codes and ordinances.
- ⚠ **ALWAYS** disconnect the pump from power source before handling or servicing.
- ⚠ Any wiring to be done on pumps should be done by a qualified electrician.
- ⚠ **NEVER** operate a pump with a power cord that has frayed or brittle insulation.
- ⚠ **NEVER** let cords or plug lay in water.
- ⚠ **NEVER** handle connected power cords with wet hands.

WARNING: RISK OF ELECTRICAL SHOCK! Single phase pumps are supplied with a grounding conductor and grounding-type attachment plug on the power cord. To reduce risk of electrical shock, be certain that it is connected only to a properly grounded, grounding-type receptacle. **DO NOT** cut off ground pin or use an adapter fitting. **DO NOT** use an extension cord with this pump.

Entire plug may be cut off if a control panel is used. All double seal pumps, all duplex installations and all three phase pumps require a control box.

Follow all local electrical and safety codes and ordinances as well as the most recent National Electric Code (NEC-ANSI/NFPA 70).

All pumps have a **GROUND WIRE** that is connected to a screw in the metal motor housing. This wire goes to the receptacle or control box which must be connected to good outside **GROUND** such as a metal water pipe or **GROUND STAKE** driven at least 8 feet into the ground.

PUMPS

- ⚠ Pumps build up heat and pressure during operation. Allow time for pump to cool before handling or servicing.
- ⚠ Only qualified personnel should install, operate or repair pump.
- ⚠ Keep clear of suction and discharge openings. **DO NOT** insert fingers in pump with power connected.
- ⚠ This pump **MUST NOT** be used to pump flammable, combustible or hazardous liquids.
- ⚠ Make sure lifting handles are securely fastened each time before lifting.
- ⚠ **DO NOT** lift pump by power cord.
- ⚠ **DO NOT** exceed manufacturers recommendation for maximum performance, as this could cause the motor to overheat.
- ⚠ **ALWAYS** secure the pump in its operating position so it can not tip over, fall or slide.
- ⚠ Keep hands and feet away from impeller when power is connected.
- ⚠ **DO NOT** use in swimming pools, decorative fountains or any installation where human contact with pumped fluid is common.
- ⚠ Do not operate pump without safety devices in place.

IMPORTANT! F.E. Myers is not responsible for losses, injury or death resulting from a failure to observe these safety precautions, misuse or abuse of pumps or equipment.

TYPICAL SECTION DRAWING FOR 3MW DOUBLE SEAL PUMPS 3450 RPM

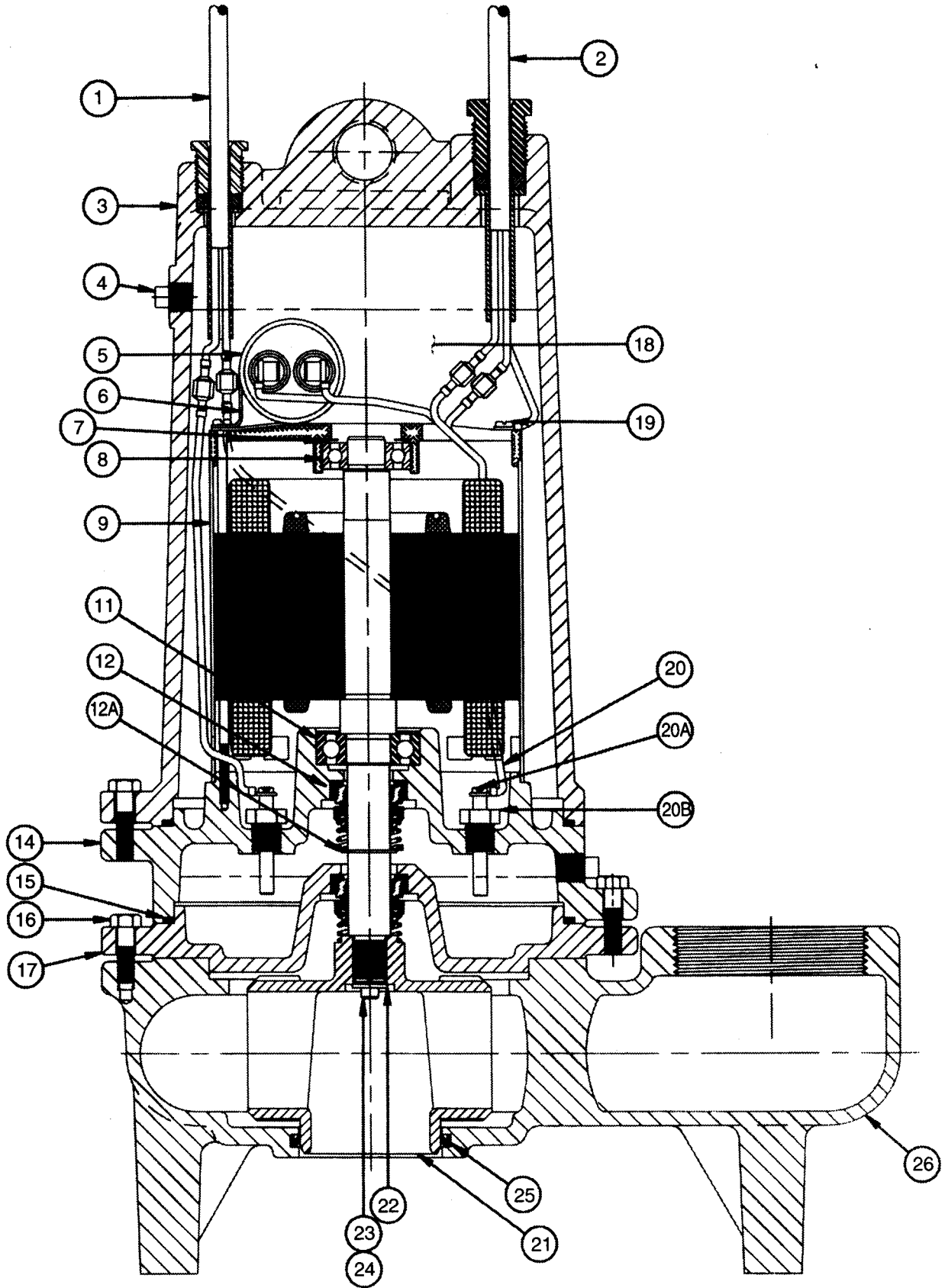

TYPICAL SECTION DRAWING FOR 3MW SINGLE SEAL PUMPS 3450 RPM

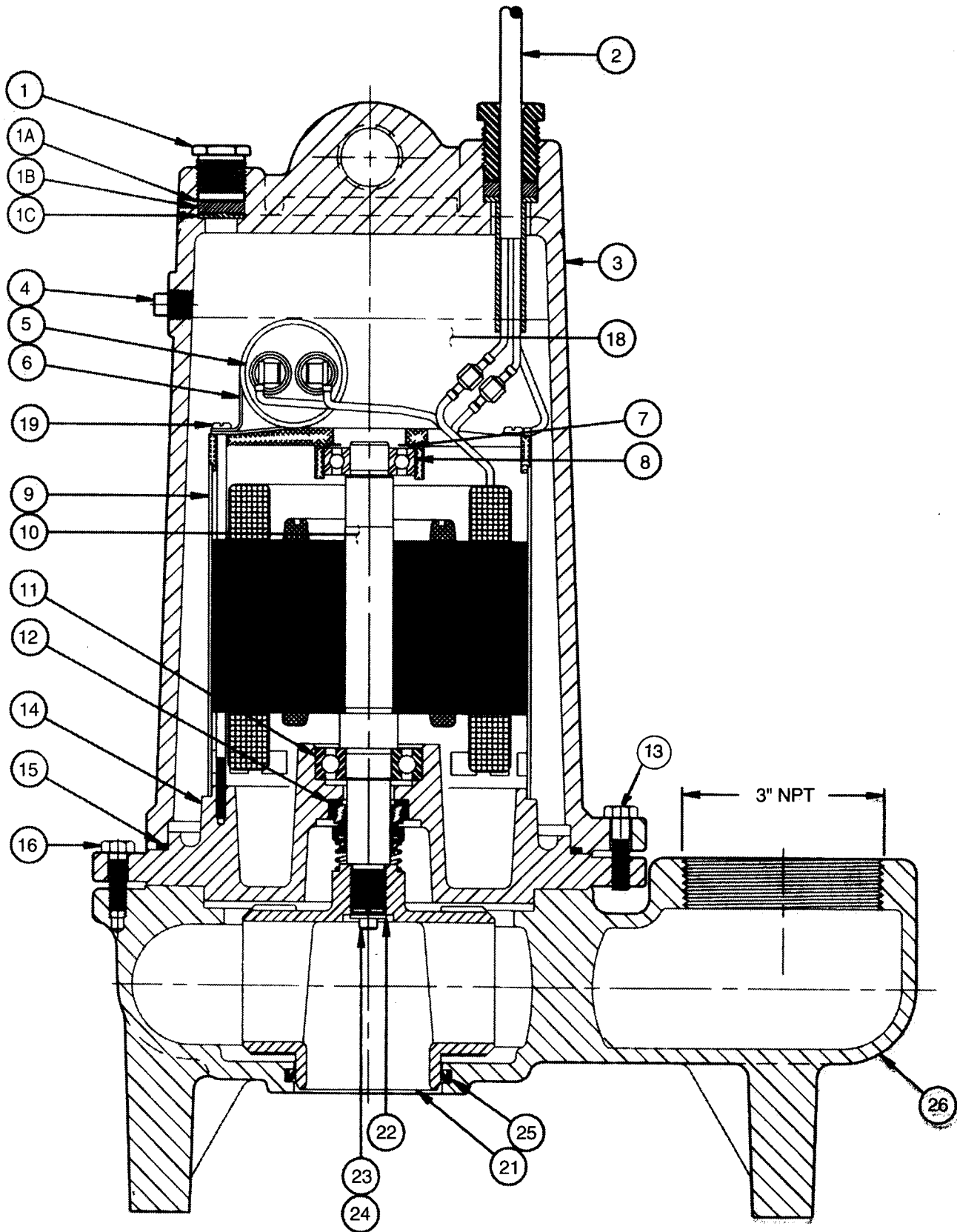

REPAIR PARTS LIST FOR 3450 RPM

Ref. No.	Description	No. Req'd	Part Numbers
1	Nut, Cord Plug, Solid	1	25341A002
1	Cord, Sensor (Double Seal)	1	25339B000
1A	Washer, 1/32" Thk.	1	05030A234
1B	Gasket, Rubber	1	05014A193
1C	Washer, 3/32" Thk.	1	05030A235
2	Cord, Power	1	See Chart
3	Housing, Motor	1	25327D000
3A	Screw, Drive (not shown)	2	05160A004
3B	Nameplate, Blank, 1 ph	1	25488A000
3B	Nameplate, Blank, 3 ph	1	25499A000
4	Plug, 1/4" Pipe	1	05022A009
	For 3MW Double Seal Series	2	
5	Capacitor (1 ph only)	1	See Chart*
6	Clip, Capacitor	1	See Chart*
7	Washer, Bearing	1	19331A005
8	Bearing, Ball, Upper	1	08565A013
9	Stator with Shell	1	See Chart*
10	Rotor with Shaft	1	See Chart*
11	Bearing, Ball, Lower	1	08565A022
12	Seal, Shaft	1	25370A000
	For 3MW Double Seal Series	2	
12A	Ring, Retaining	1	12558A033
13	Screw, Cap, 5/16 x 1-1/4	8	19100A012
	For 3MW Double Seal Series	12	

Ref. No.	Description	No. Req'd	Part Numbers
14	Plate, Seal Bearing	1	25367D000
	For 3MW Double Seal Series	1	25369D000
15	Gasket, Tetraseal 7 x 6-3/4 x 1/8	1	05014A181
	For 3MW Double Seal Series	2	
16	Screw, Cap, 5/16 x 1	4	19100A029
17	Plate, Lower Seal (Double Seal)	1	25368D000
18	Oil, Transformer	1 gal.	11009A006
	For 3MW Double Seal Series	1.12 gal.	
18A	Connectors (3 ph only)	3/6	15781A001
19	Screw, ST #10 x 3/8	2	09822A032
20	Wire Electrode	2	21792A004
20A	Screw, Machine #6 x 1/4	2	05434A025
20B	Probe, Seal Leak	2	25343A000
21	Impeller		
	1 hp	1	26029B002
	1-1/2 hp	1	26029B001
	2 hp	1	26029B000
	3 hp	1	26029B004
22	Washer, Impeller Retainer	1	05030A242
23	Screw, Machine #10 x 3/8	1	06106A042
24	Sealant (Grade 271 Loctite)	1	14550A001
25	Cup, HUVA	1	22835A009
26	Case, Volute (1750)	1	26423D000

3MW SERIES PUMPS CHART 3450 RPM

Pump Catalog Numbers	Pump Engineer Numbers	② Cord, Power	⑤ Capacitor	⑥ Clip, Capacitor	⑨ Stator w/shell	⑩ Rotor w/shaft	Style			
3MW10M2-01	26473E000	25338B001	23838A000	20333A004	25484C012	25487B014	Single Seal			
3MW10DM2-01	26474E000	25338B002				25487B019	Double Seal			
3MW10M2-21	26473E001	25338B001			25484C006	25487B014	Single Seal			
3MW10DM2-21	26474E001	25338B002				25487B019	Double Seal			
3MW10M2-03	26473E002	25338B003			—	—	25484C007	25487B015	Single Seal	
3MW10DM2-03	26474E002							25487B020	Double Seal	
3MW10M2-23	26473E003							25487B015	Single Seal	
3MW10DM2-23	26474E003							25487B020	Double Seal	
3MW10M2-43	26473E004							25487B015	Single Seal	
3MW10DM2-43	26474E004							25487B020	Double Seal	
3MW10M2-53	26473E005		25484C008	25487B015			Single Seal			
3MW10DM2-53	26474E005			25487B020			Double Seal			
3MW15M2-01	26473E010		25338B001	23838A000			20333A004	25484C014	25487B014	Single Seal
3MW15DM2-01	26474E010		25338B002						25487B019	Double Seal
3MW15M2-21	26473E011	25338B001	25484C015		25487B014	Single Seal				
3MW15DM2-21	26474E011	25338B002			25487B019	Double Seal				
3MW15M2-03	26473E012	25338B003	—	—	25484C016	25487B016	Single Seal			
3MW15DM2-03	26474E012					25487B021	Double Seal			
3MW15M2-23	26473E013					25487B016	Single Seal			
3MW15DM2-23	26474E013					25487B021	Double Seal			
3MW15M2-43	26473E014					25487B016	Single Seal			
3MW15DM2-43	26474E014					25487B021	Double Seal			
3MW15M2-53	26473E015				25484C017	25487B016	Single Seal			
3MW15DM2-53	26474E015					25487B021	Double Seal			
3MW20M2-01	26473E020				25338B001	23839A000	20333A006	25484C014	25487B014	Single Seal
3MW20DM2-01	26474E020				25338B002				25487B019	Double Seal
3MW20M2-21	26473E021	25338B001	25484C015	25487B014	Single Seal					
3MW20DM2-21	26474E021	25338B002		25487B019	Double Seal					
3MW20M2-03	26473E022	25338B003	—	—	25484C016	25487B016	Single Seal			
3MW20DM2-03	26474E022					25487B021	Double Seal			
3MW20M2-23	26473E023					25487B016	Single Seal			
3MW20DM2-23	26474E023					25487B021	Double Seal			
3MW20M2-43	26473E024					25487B016	Single Seal			
3MW20DM2-43	26474E024					25487B021	Double Seal			
3MW20M2-53	26473E025				25484C017	25487B016	Single Seal			
3MW20DM2-53	26474E025					25487B021	Double Seal			
3MW30M2-21	26473E030				25338B007	26520A000	20333A004	25484C019	25487B022	Single Seal
3MW30DM2-21	26474E030				25338B009				25487B028	Double Seal
3MW30M2-03	26473E031	25338B008	—	—	25484C020	25487B023	Single Seal			
3MW30DM2-03	26474E031					25487B029	Double Seal			
3MW30M2-23	26473E032				25484C021	25487B023	Single Seal			
3MW30DM2-23	26474E032					25487B029	Double Seal			
3MW30M2-43	26473E033	25338B003	—	—	25484C021	25487B023	Single Seal			
3MW30DM2-43	26474E033					25487B029	Double Seal			
3MW30M2-53	26473E034				25484C022	25487B023	Single Seal			
3MW30DM2-53	26474E034	25487B029	Double Seal							

TYPICAL SECTION DRAWING FOR 3MW DOUBLE SEAL PUMPS 1750 RPM

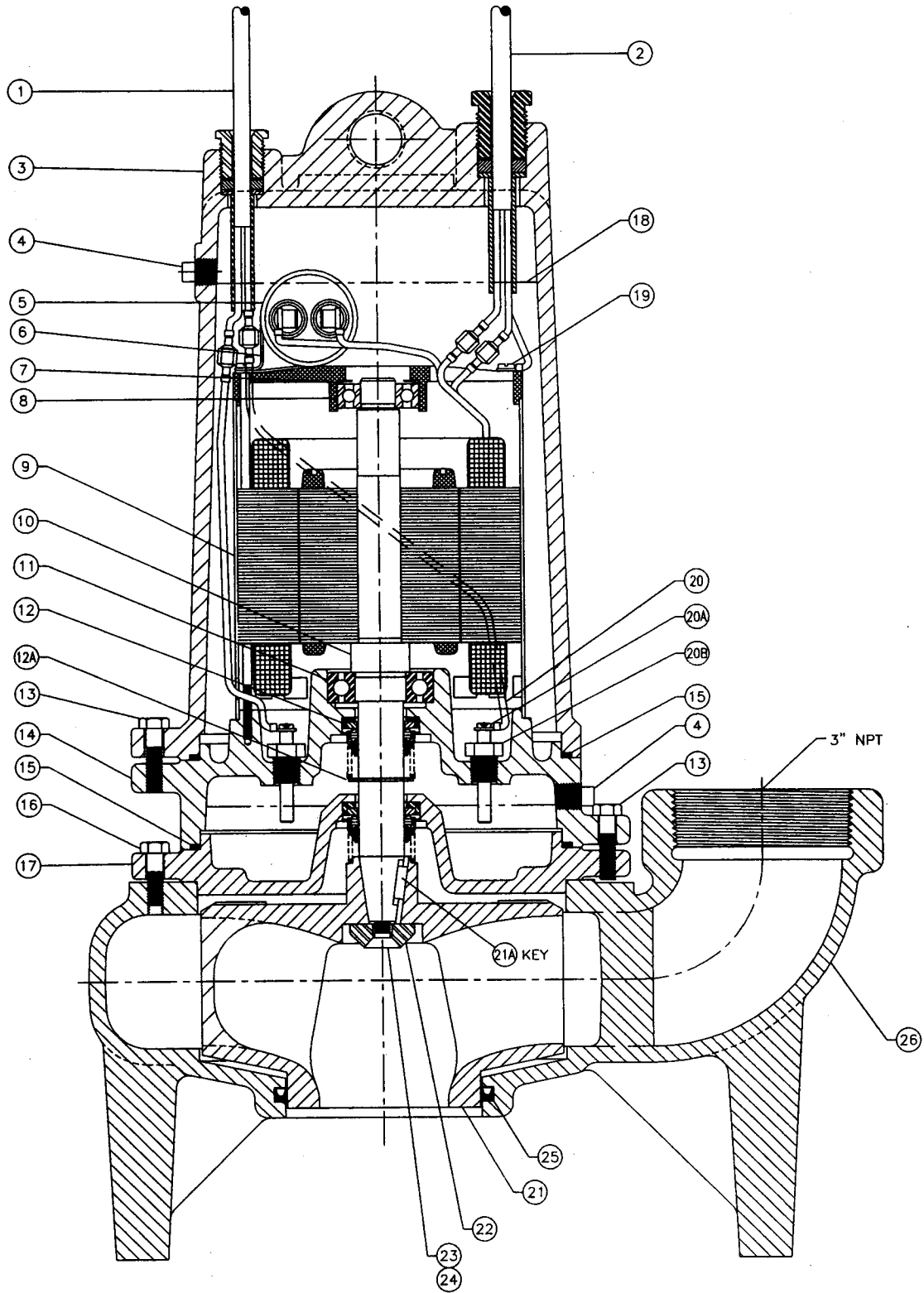

TYPICAL SECTION DRAWING FOR 3MW SINGLE SEAL PUMPS 1750 RPM

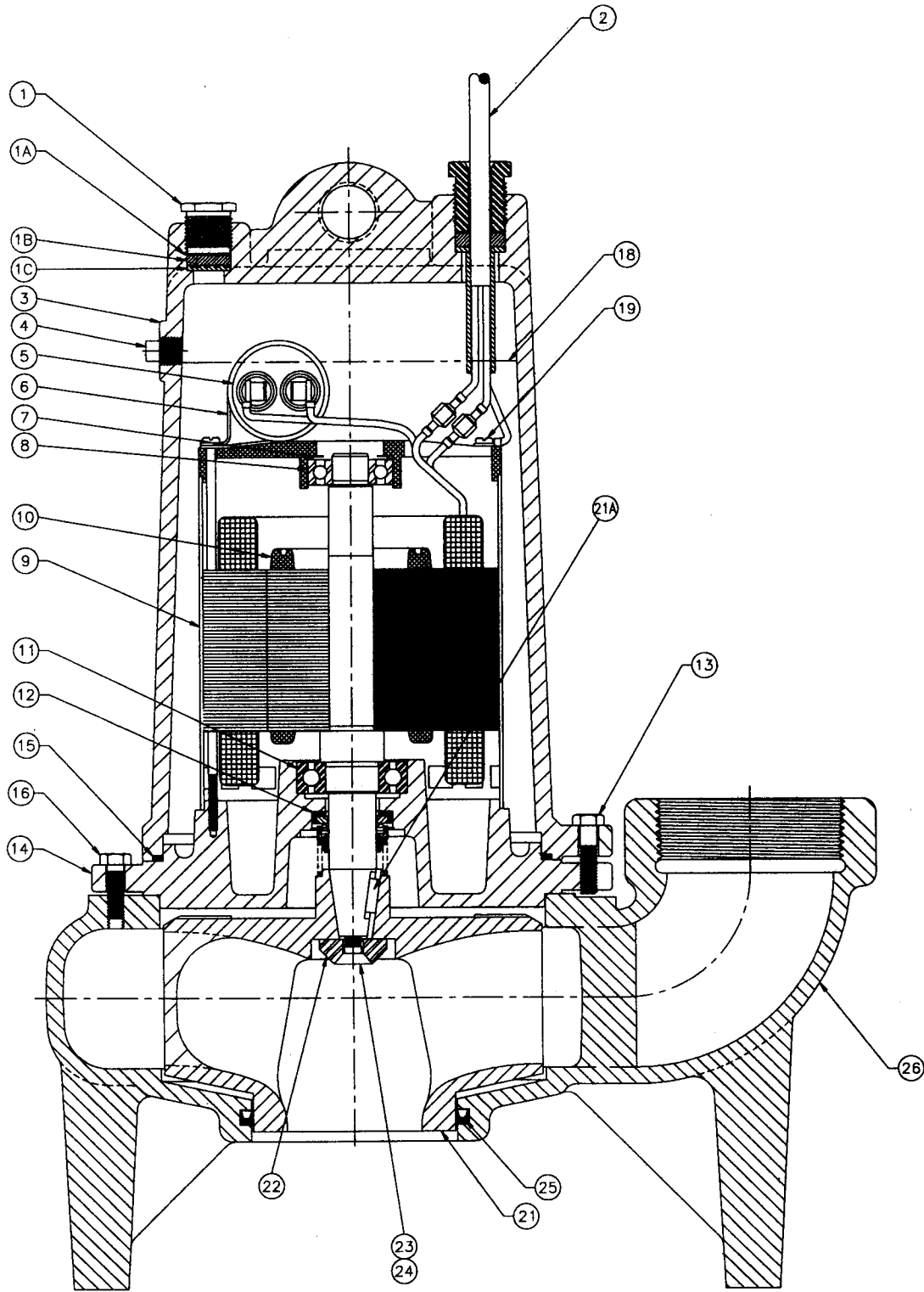

REPAIR PARTS LIST FOR 1750 RPM

Ref. No.	Description	No. Req'd	Part Numbers
1	Nut, Cord Plug, Solid	1	25341A002
1	Cord, Sensor (Double Seal)	1	25339B000
1A	Washer, 1/32" Thk.	1	05030A234
1B	Gasket, Rubber	1	05014A193
1C	Washer, 3/32" Thk.	1	05030A235
2	Cord, Power	1	See Chart
3	Housing, Motor	1	25327D000
3A	Screw, Drive (not shown)	2	05160A004
3B	Nameplate, Blank, 1 ph	1	25488A000
3B	Nameplate, Blank, 3 ph	1	25499A000
4	Plug, 1/4" Pipe	1	05022A009
	For 3MW Double Seal Series	2	
5	Capacitor (1 ph only)	1	See Chart
6	Clip, Capacitor	1	See Chart
7	Washer, Bearing	1	19331A005
8	Bearing, Ball, Upper	1	08565A013
9	Stator with Shell	1	See Chart
10	Rotor with Shaft	1	See Chart
11	Bearing, Ball, Lower	1	08565A018
12	Seal, Shaft	1	21576A010
	For 3MW Double Seal Series	2	
12A	Ring, Retaining	1	12558A006
13	Screw, Cap, 5/16 x 1-1/4	8	19100A012
	For 3MW Double Seal Series	12	

Ref. No.	Description	No. Req'd	Part Numbers
14	Plate, Seal Bearing	1	26430D000
	For 3MW Double Seal Series	1	25369D001
15	Gasket, Tetraseal 7 x 6-3/4 x 1/8	1	05014A181
	For 3MW Double Seal Series	2	
16	Screw, Cap, 5/16 x 1	4	19100A029
17	Plate, Lower Seal (Double Seal)	1	26476D000
18	Oil, Transformer	1 gal.	11009A006
	For 3MW Double Seal Series	1.12 gal.	
18A	Connectors (3 ph only)	3/6	15781A001
19	Screw, ST #10 x 3/8	2	09822A032
20	Wire Electrode	2	21792A004
20A	Screw, Machine #6 x 1/4	2	05434A025
20B	Probe, Seal Leak	2	25343A000
21	Impeller	1	26438C500*
	Impeller	1	26438C510
21A	Key	1	05818A025
22	Retainer, Impeller	1	22585A000
23	Screw, Machine 5/16 x 1	1	07597A017
24	Sealant (Grade 271 Loctite)	1	14550A001
25	Cup, HUVA	1	22835A010
26	Case, Volute (1750)	1	26437D000

* If pump was manufactured prior to June 2001 order indicated (*) number.

3MW SERIES PUMPS CHART 1750 RPM

Pump Catalog Numbers	Pump Engineering Numbers	② Cord Power	⑤ Capacitor	⑥ Clip Capacitor	⑨ Stator w/shell	⑩ Rotor w/shaft*	Style
3MW15M4-01	26471E000	25338B007	26520A001	20333A004	25484C023	25487B124	Single Seal
3MW15DM4-01	26472E000	25338B009				25487B130	Double Seal
3MW15M4-21	26471E001	25338B007			25484C024	25587B124	Single Seal
3MW15DM4-21	26472E001	25338B009				25487B130	Double Seal
3MW15M4-03	26471E002	25338B008	---	---	25484C025	25487B125	Single Seal
3MW15DM4-03	26472E002					25487B131	Double Seal
3MW15M4-23	26471E003				25484C026	25487B125	Single Seal
3MW15DM4-23	26472E003					25487B131	Double Seal
3MW15M4-43	26471E004	25338B003	---	---	25484C027	25487B125	Single Seal
3MW15DM4-43	26472E004					25487B131	Double Seal
3MW15M4-53	26471E005				25487B125	Single Seal	
3MW15DM4-53	26472E005				25487B131	Double Seal	
3MW20M4-01	26471E010	25338B007	26520A001	20333A004	25484C023	25487B124	Single Seal
3MW20DM4-01	26472E010	25338B009				25487B130	Double Seal
3MW20M4-21	26471E011	25338B007			25484C024	25487B124	Single Seal
3MW20DM4-21	26472E011	25338B009				25487B130	Double Seal
3MW20M4-03	26471E012	25338B008	---	---	25484C025	25487B125	Single Seal
3MW20DM4-03	26472E012					25487B131	Double Seal
3MW20M4-23	26471E013				25484C026	25487B125	Single Seal
3MW20DM4-23	26472E013					25487B131	Double Seal
3MW20M4-43	25471E014	25338B003	---	---	25484C027	25487B125	Single Seal
3MW20DM4-43	26472E014					25487B131	Double Seal
3MW20M4-53	26471E015				25487B125	Single Seal	
3MW20DM4-53	26472E015				25487B131	Double Seal	
3MW30M4-21	26471E021	25338B007	26520A000	20333A004	25484C028	25487B126	Single Seal
3MW30DM4-21	26472E021	25338B009				25487B132	Double Seal
3MW30M4-03	26471E022	25338B008	---	---	25484C029	25487B127	Single Seal
3MW30DM4-03	26472E022					25487B133	Double Seal
3MW30M4-23	26471E023				25484C030	25487B127	Single Seal
3MW30DM4-23	26472E023					25487B133	Double Seal
3MW30M4-43	26471E024	25338B003	---	---	25484C031	25487B127	Single Seal
3MW30DM4-43	26472E024					25487B133	Double Seal
3MW30M4-53	26471E025	25338B003	---	---	25484C031	25487B127	Single Seal
3MW30DM4-53	26472E025					25487B133	Double Seal

NOTE: If pump was manufactured prior to June 2001, order rotor as follows:
 25487B124 new keyed style (listed above) or
 25487B024 old threaded style (replace "1" with an "0")

GENERAL DESCRIPTION AND APPLICATION

Myers 3MW series sewage pumps are available in both a single seal and double seal with leak detector. Also 3MW series sewage pumps are also available in 1750 rpm and 3450 rpm models and are designed for raw sewage applications. The 3450 rpm series can pass a 2" spherical solids, and the 1750 rpm series can pass 2-1/2" spherical solids. These units can also be used for sump and general dewatering applications where larger solids capabilities are required.

These pumps are available in single and three phase, and either in single or double seal with seal leak detector. All three phase units, all double seal units and all duplex installations must be used with a control box. All power cords and seal leak detector cords are standard 20 feet long.

The 3MW model impellers are enclosed two vane non-clog style, with 1750 rpm designed to pass 2-1/2" spherical solids and 3450 rpm designed to pass 2" spherical solids.

THESE PUMPS ARE NOT FOR USE IN SWIMMING POOLS OR FOUNTAINS.

AIR VENTING

Upon initial filling of wet well with water, air may be trapped in the pump volute. To vent off this air a 5/32" diameter hole is located in volute. **BE SURE THIS VENT HOLE IS CLEAN AFTER ANY SERVICE WORK ON PUMP.**

PACKAGING

Each pump is packed separately in a carton marked with a catalog number and Myers engineering number.

LEVEL CONTROLS

All pumps must use sealed level control switches for automatic operation.

Simplex single phase pumps can be made automatic by attaching MFS controls to the pump or discharge pipe. These switches have a fixed draw off level of 8 to 10 inches and can be used up to 1 HP. Simplex and higher horsepower systems may also use on/off pilot control switches (SMNO) with control box and magnetic starter. The ALC and AWS-1 controls can be used for simplex single phase pumps with ratings up to 2 HP. All duplex systems must use pilot control switches (SMNO) with control box and magnetic starters.

Plug-in cords can be used on all the single phase pumps with a single seal (does not have seal leak detector). This cord has a **GROUND** pin that plugs into a grounded receptacle. The grounded receptacle cannot be used in the wet sump or basin due to **DANGER** of current leakage. Sealed junction boxes must be used in wet sumps or basins to make connections to motor cord. The AWS-1 control also acts as a sealed junction box for connecting power cord to pump cord.

DOUBLE SEAL PUMPS

All pumps in this series "3MW—D" have two seals with an oil chamber between the seals so that the seal faces of both the lower and upper seals are oil lubricated for longer life and greater protection against water leaking into motor windings. These double seal units are all made with a seal leak detector.

The leak detector in the oil seal chamber detects a water leakage into the chamber and turns on red signal light in the control panel. Pumps should be removed from the sump and seals replaced after the seal light shows in panel. Control panels must be used for pumps having the seal leak detectors, and seal leak detectors **must** be wired as illustrated in these instructions.

DESIGN OF PRESSURE SEWER SYSTEMS

MYERS has available complete computer SOFTWARE for designing PRESSURE SEWER SYSTEMS. This gives pipe sizes to use and gives exact flow from any pump or group of pumps in the system when operating simultaneously.

This design DISK for IBM or COMPATIBLE computers is available to engineers on request.

MOTOR TYPE

Motors are 3/4 frame 1 - 3 HP single or three phase, 60 hertz, 1750 & 3450 R.P.M. with class B insulation. All single phase motors are permanent split-capacitor (PSC) type with built-in on-winding overload protection and do not require a start switch or start relay. The three phase pump motors require a magnetic starter with 3 leg overload protection. All motors have upper and lower ball bearings and all are oil-cooled and lubricated.

CAUTION! Read these safety warnings first before installing, servicing, or operating any pump.

UL AND CSA APPROVAL

All pumps have UL and CSA approval pending. Myers is a SSPMA certified pump member.

INSTALLATION

WARNING: Basin or tank must be vented in accordance with local plumbing codes. These pumps are not designed for and **CANNOT** be installed in locations classified as hazardous in accordance with the National Electric Code ANSI/NFPA 70. **CAUTION:** Never enter pump chamber after sewage or effluent has been in basin. Sewage water can give off methane, hydrogen sulfide and other gasses which are highly poisonous. For this reason, Myers recommends installing the 3MW series sewage pumps with a quick removal system. The quick removal system may be a union or Cam-lok coupling if the pipe or discharge hose is within reach from the surface, or an SRA-300 rail system type quick disconnect on deeper installations. See installation drawings for suggested installation.

The dosing tank or pumping chamber must be constructed of corrosion resistant materials and must be capable of withstanding all anticipated internal and external loads. It also must not allow infiltration or exfiltration. The tank must also have provisions for anti-buoyancy. Access holes or covers must be of adequate size and be accessible from the surface to allow installation and maintenance of the system. **ACCESS COVERS MUST BE LOCKABLE OR HEAVY ENOUGH TO PREVENT EASY ACCESS TO UNAUTHORIZED PERSONNEL.** The pumping chamber holding capacity should be selected to allow for emergency conditions.

The discharge pipe must be the same size as the pump discharge (3 inches) or larger. In order to ensure sufficient fluid velocity to prevent any residual solids from collecting in the discharge pipe, it is recommended that a minimum flow of 2 feet per second be maintained. (46 gpm through 3" pipe). It is recommended that a PVC or equal pipe is used for corrosion resistance. A full flow (ball or gate) shut off valve must be installed to prevent back flow of sewage if the pump must be removed for service. **A CHECK VALVE MUST BE INSTALLED ON PRESSURE SEWER SYSTEMS** and on other systems where conditions allow to prevent backflow and to reduce wear on the pump system.

A high water alarm must be installed on a separate circuit from the pump circuit. The alarm should have the ability to be tested for proper operation.

SPECIAL INSTRUCTIONS FOR THREE PHASE PUMPS

- (1) F.E. Myers recommends three phase pumps to be installed by qualified personnel. **CAUTION: RISK OF ELECTRICAL SHOCK! Do not remove cord and strain relief. DO NOT connect conduit to pump.**
- (2) Three phase pumps are always installed with control boxes having magnetic starters with 3 leg overload protection. **DO NOT TRY TO RUN THREE PHASE PUMPS DIRECTLY ACROSS THE LINE.**
- (3) **To Connect Pump:** Run wire from pump to bottom of control box or appropriate junction box suitable for enclosing splice connections. A hole must be cut into the control box for the wires. With power to control box **OFF**, connect green (ground) line to ground lug. Connect black (power) wires to power lead terminals. Note: for a typical CE style control box, these terminals are M1, M2 and M3. Make sure that all wires are inside control box and not in a position to be pinched or shorted when door is closed.
- (4) **Before installing pumps check rotation of impeller** to make sure pump is connected correctly to magnetic starter. All pump impellers either single or three phase must turn counterclockwise when looking into pump inlet. To check for proper rotation lay pump on side so impeller is visible. Turn on

power and start pump using HAND position of H-O-A switch. Turn on and off fast so that coast of impeller can be seen. **NEVER PUT HANDS OR FINGERS ON THE IMPELLER WHEN POWER IS CONNECTED.** Interchange any two line leads at magnetic starter to change rotation if incorrect.

POINTS TO CHECK IF PUMP DOES NOT RUN OR DOES NOT RUN PROPERLY

- (1) **Pump does not run or start when water is up in tank.**
 - (a) Check for blown fuse or tripped circuit breaker.
 - (b) Check for defective level switch.
 - (c) Where control panel is used be sure H-O-A switch is in the AUTO position. If it does not run, turn switch to HAND position and if pump runs then the trouble is in the automatic electrical system. Have an ELECTRICIAN make electrical checks.
 - (d) Check for burned out motor. Occasionally lightning can damage a motor even with lightning protection.
 - (e) Where plug-in cords used be sure contact blades are clean and make good contact. **DO NOT USE PLUG-IN CORDS INSIDE A SUMP OR WET WELL.**
 - (f) Level control ball or weight may be stuck on the side of basin. Be sure it floats freely.
- (2) **Pump runs but does not deliver flow.**
 - (a) Check air lock. Start and stop pump several times, if this does not help it may be necessary to loosen a union in the discharge line to relieve air lock.
 - (b) Check valve may be installed backwards. Check flow arrow on valve body. Check shut-off valve. It may be closed.
 - (c) Check vertical elevation. It may be higher than pump can develop (see pump curve).
 - (d) Pump inlet may be plugged. Remove pump to check.

CAUTION: ALWAYS UNPLUG POWER CORDS OR TURN OFF ALL MAIN AND BRANCH CIRCUIT BREAKERS BEFORE DOING ANY WORK ON THE PUMP. If control panel is remote from pump, disconnect lead wires to motor so that no one can turn the circuit breaker back on. If motor is three phase mark the leads so they can be replaced in the same order.

BEFORE DISMANTLING PUMP FOR REPLACEMENT OF PARTS

CLEAN PUMP THOROUGHLY. KNOCK OFF ALL SCALE AND DEPOSITS. USE SANDBLAST IF POSSIBLE. SUBMERGE COMPLETE UNIT IN CLOROX SOLUTION FOR ONE HOUR BEFORE TAKING APART.

36" DIAMETER SIMPLEX UNION SYSTEM 3MW 1 - 3 HP

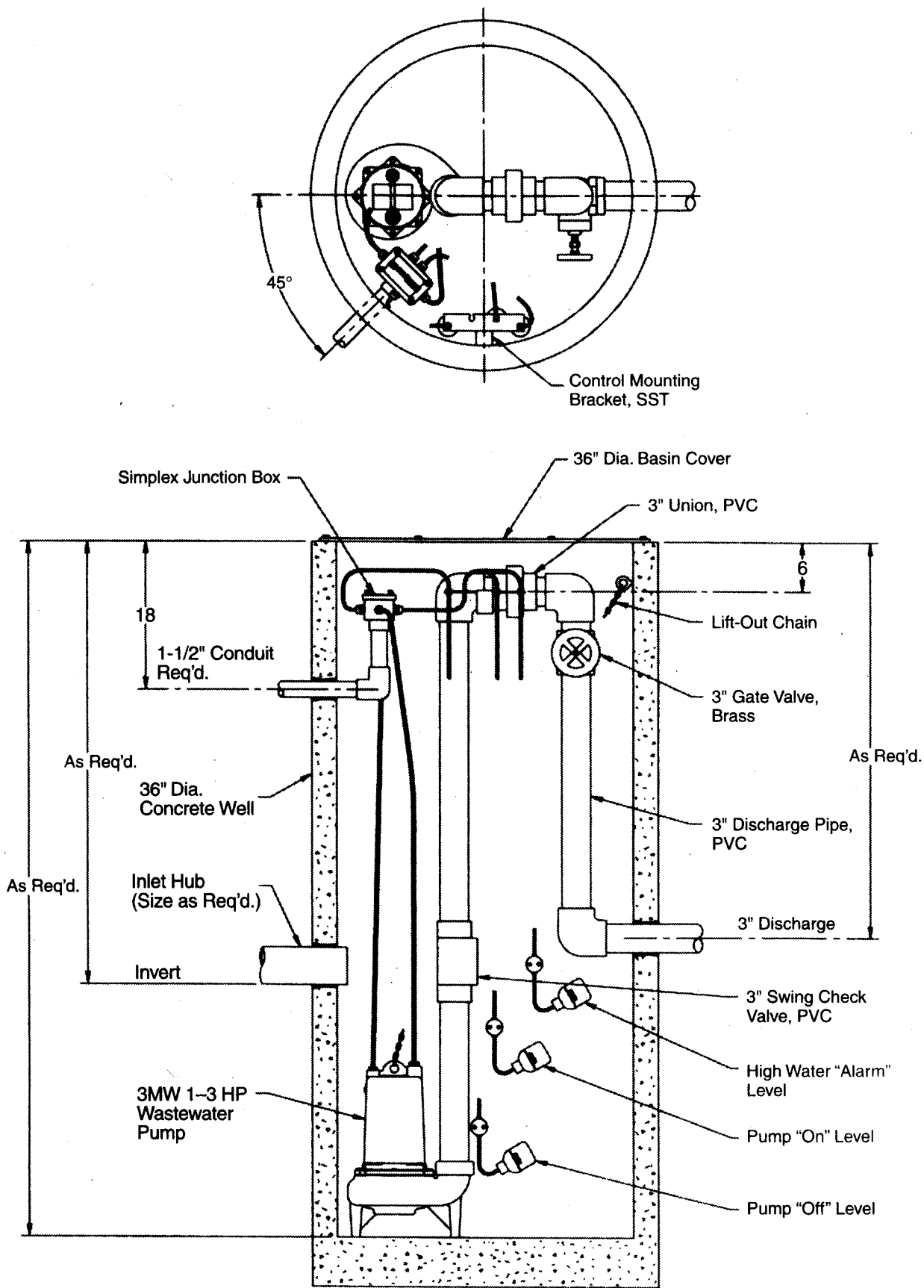

48" DIAMETER SIMPLEX 3MW 1 - 3 HP

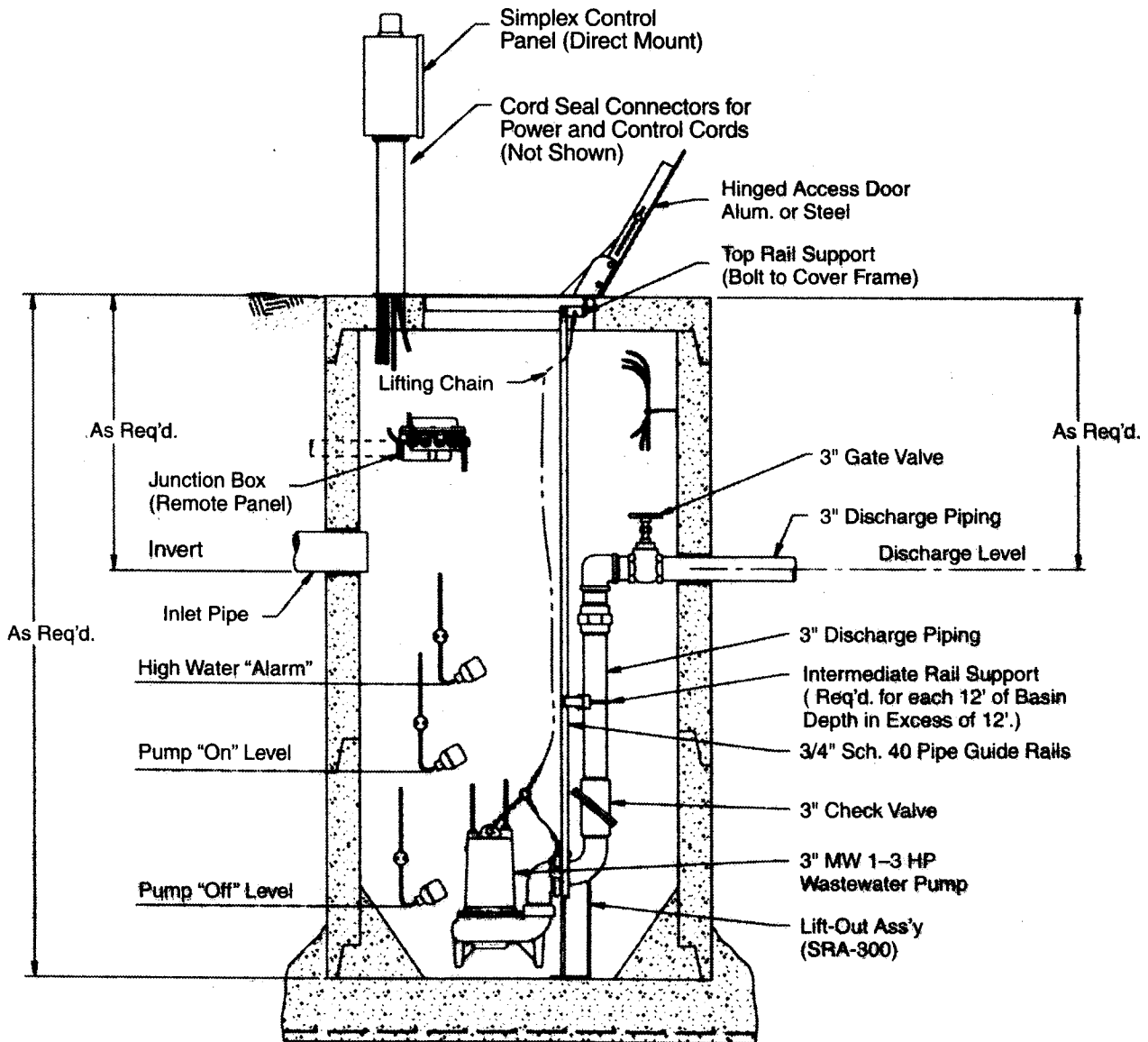
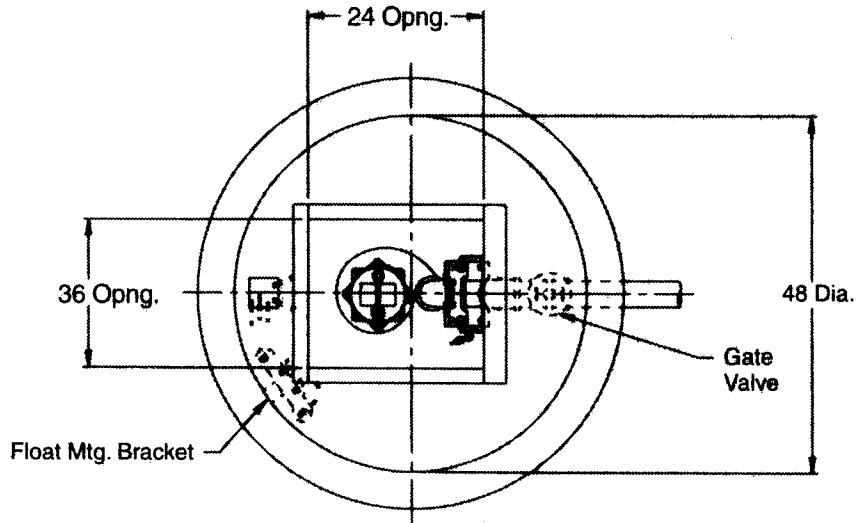

60" DIAMETER DUPLEX 3MW 1 - 3 HP

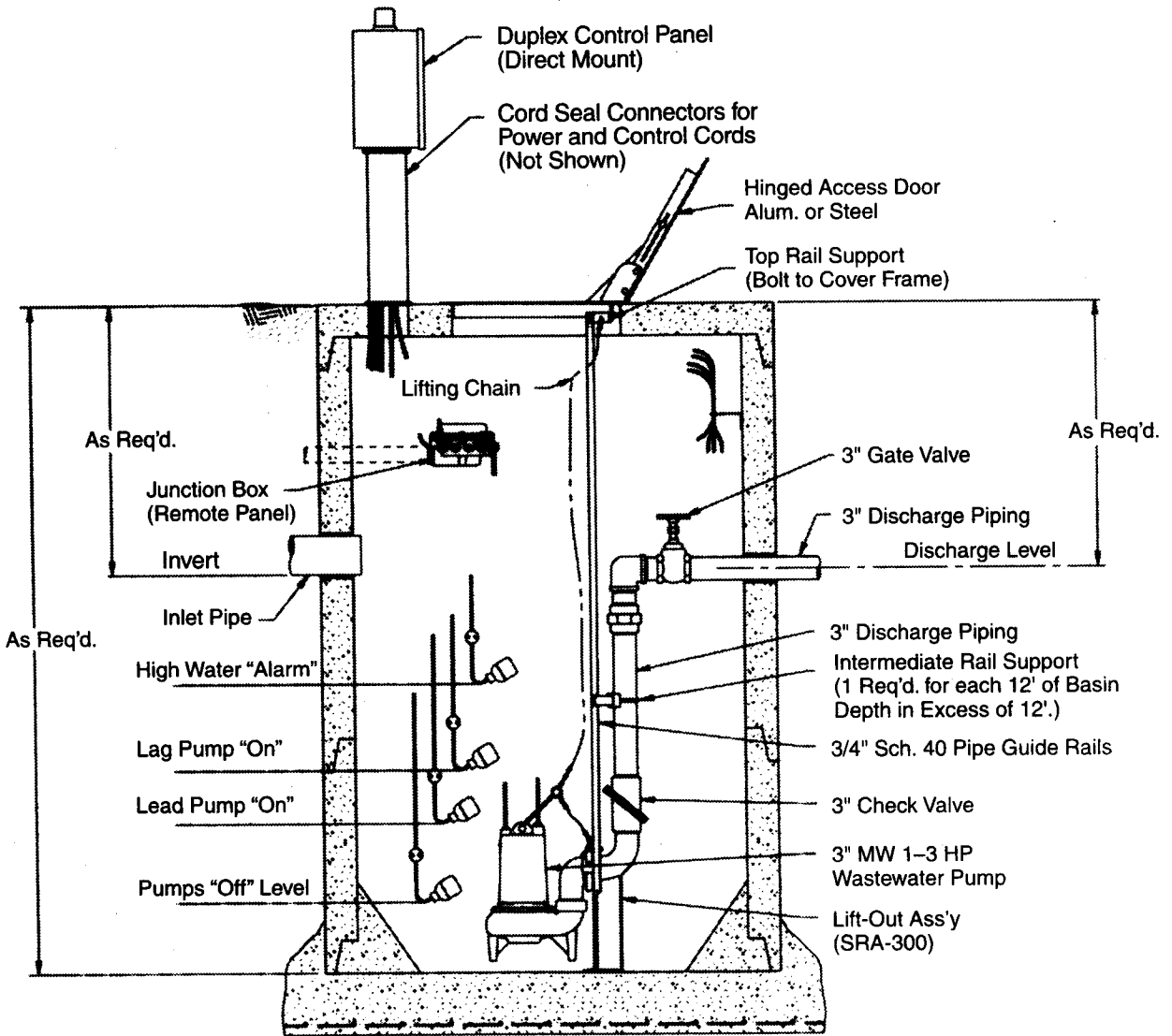
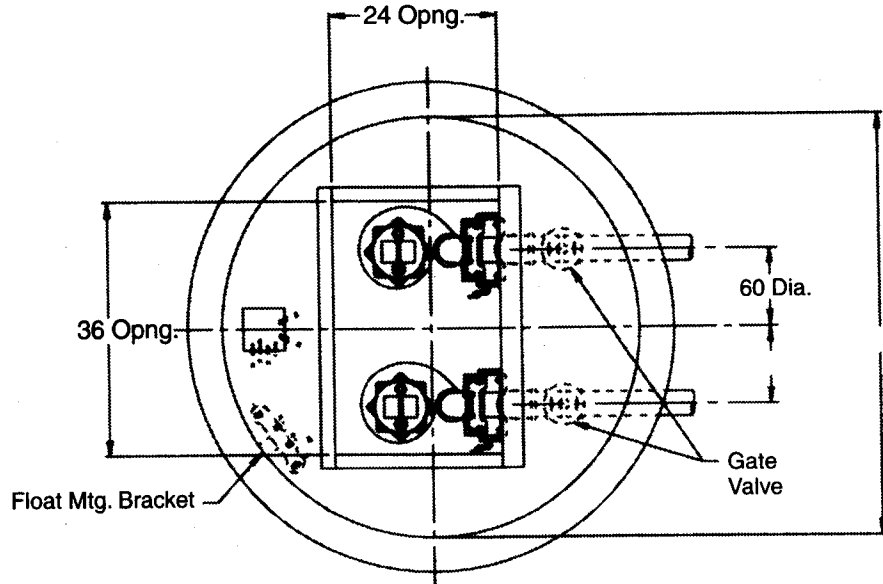

TO REPLACE CAPACITORS ONLY

All of the single phase motors are of the permanent split capacitor type and have no relays or starting switch. They have only a starting capacitor that is in the circuit for both starting and running conditions.

- (1) Remove oil fill plug near the top of the motor and pour the oil out.
- (2) Loosen the plug nuts around the cords until they are loose enough to push the cords down inside of the motor housing.
- (3) Remove the four bolts from the motor housing and bump the housing with a plastic hammer to loosen. Lay the pump on its side.
- (4) Remove the housing carefully to be sure that enough cord is pushed into the housing to create no tension on the cords.
- (5) Slide motor housing up far enough to expose the capacitor and to be able to lay the housing down.

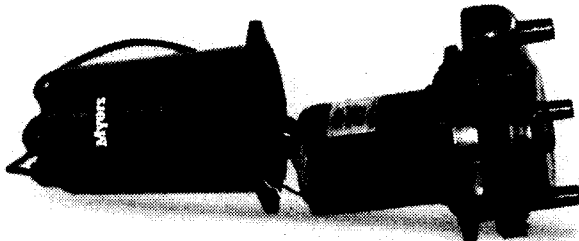

- (6) Disconnect wiring from capacitor and loosen capacitor clamp and slide out capacitor. Replace with new capacitor, tighten and re-connect. Wiring diagram is given in these instructions.
- (7) Check all wiring connectors to be sure they are secure.
- (8) Be sure tetraseal gasket is in place.
- (9) Slide motor housing back onto pump while pulling the cords out slowly. Assemble the motor housing with the four bolts.
- (10) Re-assemble cord nuts. Be sure washers are seated and cords are pulled up to stop against the washers. Tighten nuts securely.
- (11) Put pump upright and refill motor with Myers submersible motor oil. **DO NOT OVER FILL WITH OIL.** With pump upright fill oil to bottom of oil fill tapping. Replace oil fill plug.
- (12) Be sure pump turns freely before connecting to power. Turn pump on side and turn impeller, using screwdriver in slotted shaft. Plug pump into receptacle to test operation. Pump must run quiet and free of vibration.

TO REPLACE POWER CORD AND/OR SEAL LEAK DETECTOR CORD

- (1) Remove motor housing as described above. Disconnect the push-together terminals and remove the ground screw from the power cord if being replaced.

- (2) Completely unscrew cord bushing to be replaced and remove cord assembly from housing. Be sure remaining terminals are secure on the wires.
- (3) Replace with proper cord with fittings. Push cord into the motor housing far enough to make proper connections. Re-connect ground wire if replacing power cord and securely connect the wires correctly. See wiring diagram in these instructions.
- (4) Assemble cords and motor housing as described in "Capacitor Replacement". Fill with oil as noted and be sure pump turns freely before connecting to power.

TO REPLACE MOTOR STATOR AND SHELL

- (1) Remove motor housing as described above.
- (2) Disconnect all leads from power and seal leak cords and ground wire and set pump upright.
- (3) Loosen the four long screws holding the motor and remove slowly. If unit has seal leak probes be sure to feed the wires through the slots as the motor is being removed.
- (4) Either remove previous capacitor and clamp from old motor and assemble onto new stator and shell or replace with a new capacitor and assemble the two capacitor leads per wiring diagram.
- (5) Position bearing spring washer on top of upper ball bearing. (For 1 - 3 HP as shown in Figure 1.)
- (6) Tighten terminal screws of seal leak probes and feed wires through the motor slots.

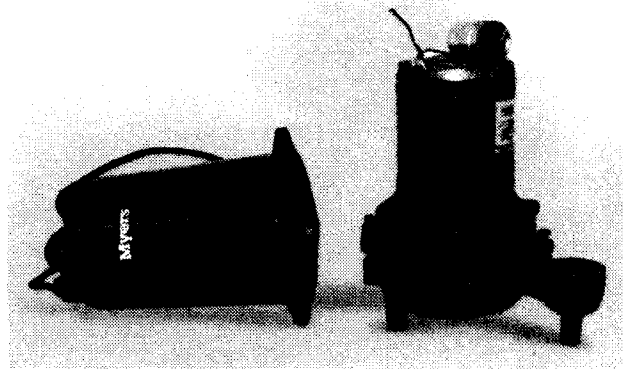

- (7) Position the "stator with shell" into place and line up screws with the bosses and tighten the (4) long screws. Extend probe wires out through the slots. Lay unit down in line with motor housing.
- (8) Be sure pump turns freely with screwdriver in impeller end of shaft.
- (9) Re-connect all terminals securely per wiring diagram.
- (10) Be sure tetraseal gasket is in place.
- (11) Reassemble motor housing and fill with oil as noted above in "capacitor replacement".

NOTE: On three phase motors always check unit for proper rotation. With pump on its side apply power by turning on, then off, quickly. Impeller must turn counter-clockwise when looking into the impeller inlet. If not, interchange any two leads in the control box.

SHAFT SEAL REPLACEMENT

- (1) Remove plugs in motor housing and in seal housing (for double seal units) and drain oil.
- (2) Remove four bolts holding the volute case and bump with a plastic hammer to loosen and remove case.

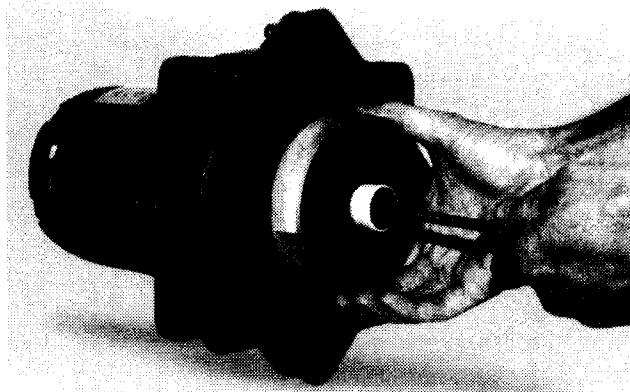

- (3) Hold impeller and unscrew impeller locking screw. Turn counterclockwise to loosen.
- (4) Pry off seal bellows and ceramic seat. Break seats if necessary to get out since they must be replaced with new parts.
- (5) NEVER USE OLD SEAL PARTS. USE ONLY COMPLETELY NEW SEALS. (Do not use seal spring retainer plate on single seal pump or lower seal of double seal pump.)
- (6) For single seal pumps or if only replacing the lower seal of a double seal pump it is not necessary to disassemble further and on a double seal pump it is not necessary to drain oil out of the motor housing, just the seal housing.
- (7) On a double seal pump to remove the upper seal, remove four bolts holding the bottom plate and remove bottom plate.

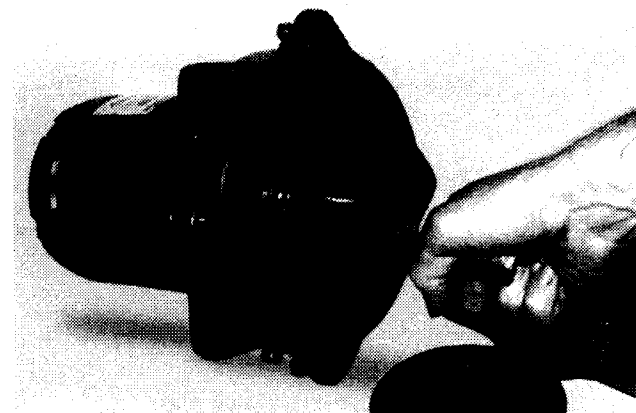

- (8) Remove snap ring with snap ring pliers. Pry off upper seal bellows and ceramic seat.
- (9) If no water has entered motor housing (check winding with ohmmeter or megger) wipe seal chambers thoroughly and replace seals. (Use seal retainer plate on upper seal only, do not use on lower seal.) Clean seal faces and use light oil on face before installing bellows part of seal.
- (10) Check HUVA cup seal in volute case inlet. If worn, replace.
- (11) Be sure tetraseal seal is in position (replace if worn) and reassemble.
- (12) Replace oil in motor housing and seal chamber. Use only Myers submersible oil.
- (13) Be sure pump turns freely before connecting to power. After connecting, check for proper rotation noted under "Stator Replacement".

WIRING DIAGRAM

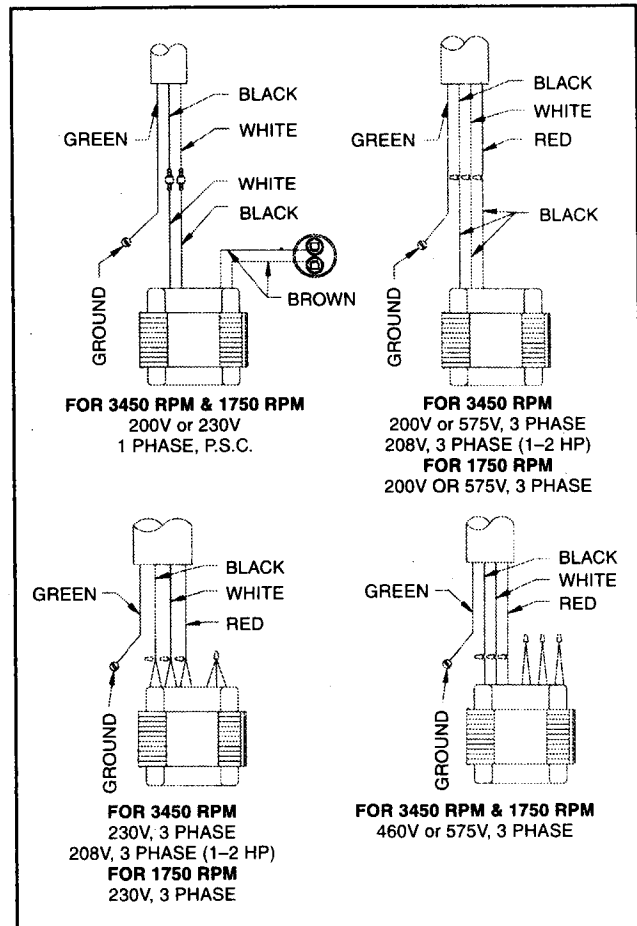

3 PHASE DUAL VOLTAGE WINDING

VOLTAGE	LEADS			
	BLACK	WHITE	RED	TOGETHER
230	1 & 7	2 & 8	3 & 9	4 & 5 & 6
460	1	2	3	4 & 7, 5 & 8, 6 & 9

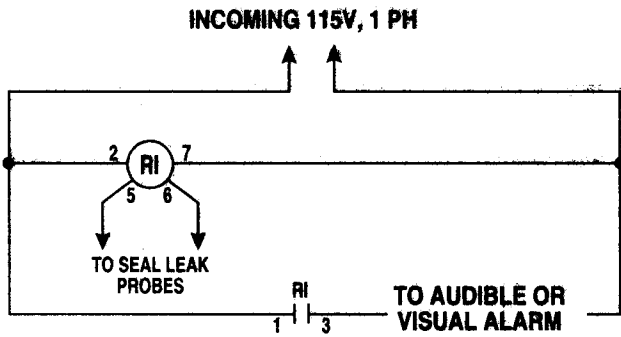

MOISTURE SENSOR SEAL PROBE CIRCUIT

Relay - SSAC Inc. #LLC44A5A

Socket - Standard 8-pin plug-in type

If Myers panel is used see below.

Pumps: 3MW10DM2-01, 3MW10DM2-21
 3MW15DM2-01, 3MW15DM2-21
 3MW20DM2-01, 3MW30DM2-21
 3MW15DM4-01, 3MW15DM4-21
 3MW20DM4-01, 3MW20DM4-21

Required Panel:
 CMEP(SL)-21S,-21SW,-21D, or -21DW

Pumps: 3MW10DM2-03, 3MW10DM2-23
 3MW15DM2-03, 3MW15DM2-23
 3MW20DM2-03, 3MW30DM2-23
 3MW15DM4-03, 3MW15DM4-23
 3MW20DM4-03, 3MW20DM4-23

Required Panel:
 CMEP(SL)-23S,-23SW,-23D or -21DW

Pumps: 3MW10DM2-43
 3MW15DM2-43
 3MW20DM2-43
 3MW15DM4-43
 3MW20DM4-43

Required Panel:
 CMEP(SL)-43S,-43SW,-43D or -43DW

Pumps: 3MW30DM2-21
 3MW30DM4-21

Required Panel:
 CMWD-30-21S,-21SW,-21D or -21DW

Pumps: 3MW30DM2-03
 3MW30DM2-23
 3MW30DM4-03
 3MW30DM4-23

Required Panel:
 CMWD-30-23S,-23SW,-23D or -23DW

Pumps: 3MW30DM2-43
 3MW30DM4-43

Required Panel:
 CMWD-30-43S,-43SW,-43D or 43DW

3MW DIMENSIONS FOR 3450 RPM

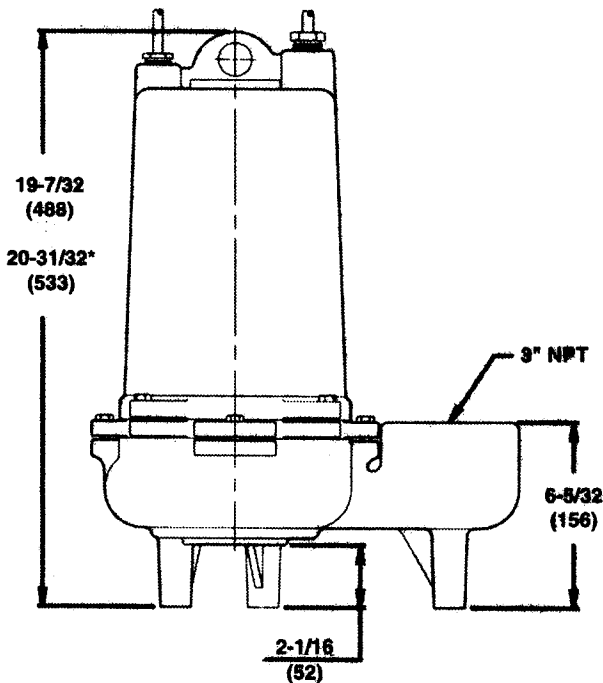
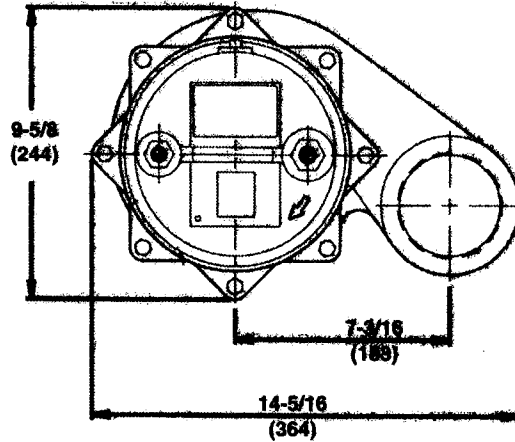

* Height for Double Seal Units

3MW DIMENSIONS FOR 1750 RPM

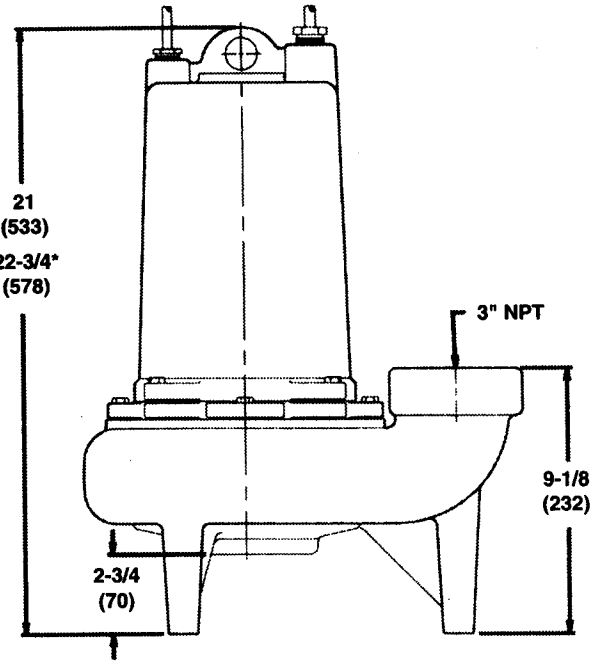
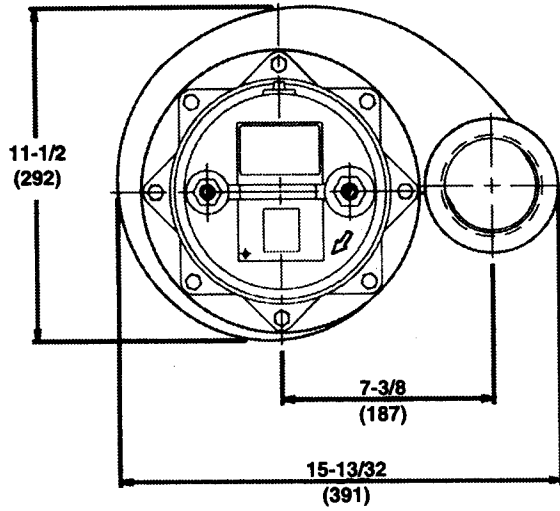

3MW PERFORMANCE CURVE FOR 3450 RPM

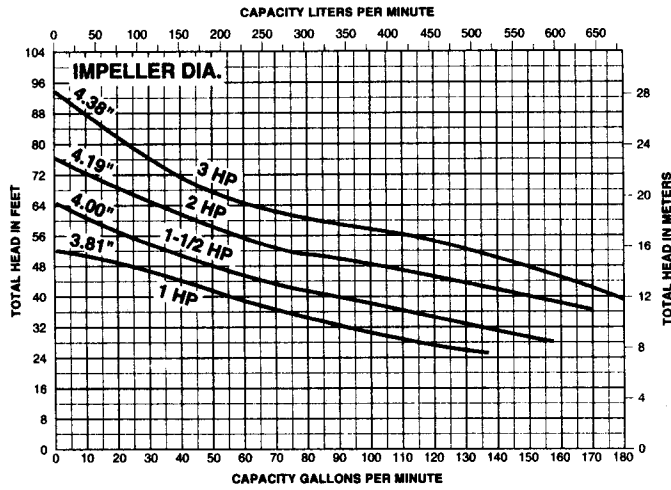

* Height for Double Seal Units

3MW PERFORMANCE CURVE FOR 1750 RPM

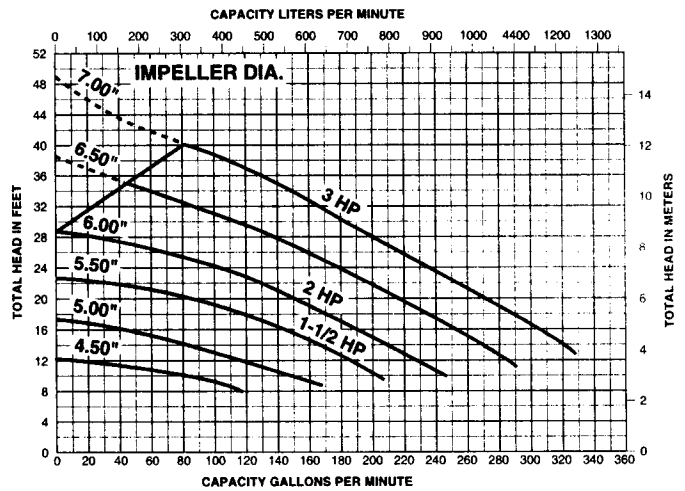

MOTOR DATA CHART

H.P.	SPEED	VOLTS	PHASE	STACK HEIGHT	WINDING RESISTANCE IN OHMS			MAX. AMPS	LOCKED ROTOR AMPS
					MAIN BLACK TO WHITE	START - 1Ø BRN. TO BRN. OR PURPLE	WHITE TO RED		
						BLACK TO RED - 3Ø			
1	3450	208	1	2-3/4	2.2	11.5	-	10.3	21.0
1	3450	230	1	2-3/4	2.8	15.0	-	9.3	19.0
1	3450	208	3	2-1/2	5.3	5.3	5.3	6.6	29.0
1	3450	230	3	2-1/2	5.3	5.3	5.3	6.0	29.0
1	3450	460	3	2-1/2	21.2	21.2	21.2	3.0	14.5
1	3450	575	3	2-1/2	33.1	33.1	33.1	2.5	11.6
1-1/2	3450	208	1	2-3/4	2.1	9.3	-	14.8	39.9
1-1/2	3450	230	1	2-3/4	1.6	7.4	-	12.8	33.4
1-1/2	3450	208	3	2-3/4	4.5	4.5	4.5	7.7	30.0
1-1/2	3450	230	3	2-3/4	4.5	4.5	4.5	7.0	30.0
1-1/2	3450	460	3	2-3/4	18.0	18.0	18.0	3.5	15.0
1-1/2	3450	575	3	2-3/4	28.0	28.0	28.0	2.8	12.0
2	3450	208	1	2-3/4	2.1	9.3	-	15.3	39.9
2	3450	230	1	2-3/4	1.6	7.4	-	13.1	33.4
2	3450	208	3	2-3/4	4.5	4.5	4.5	8.5	30.0
2	3450	230	3	2-3/4	4.5	4.5	4.5	7.7	30.0
2	3450	460	3	2-3/4	18.0	18.0	18.0	3.9	15.0
2	3450	575	3	2-3/4	28.0	28.0	28.0	3.1	12.0
3	3450	230	1	3	1.43	1.94	-	18.0	63.0
3	3450	208	3	2-1/2	2.3	2.3	2.3	10.4	53.0
3	3450	230	3	2-1/2	2.6	2.6	2.6	9.0	46.0
3	3450	460	3	2-1/2	10.4	10.4	10.4	4.5	23.0
3	3450	575	3	2-1/2	13.1	13.1	13.1	3.6	18.4
1-1/2	1750	200	1	2-3/4			-	13.8	25.2
1-1/2	1750	230	1	2-3/4	2.2	14.9	-	12.0	24.0
1-1/2	1750	200	3	2-1/2	2.7	2.7	2.7	9.8	36.8
1-1/2	1750	230	3	2-1/2	3.1	3.1	3.1	8.6	32.0
1-1/2	1750	460	3	2-1/2	12.5	12.5	12.5	4.3	16.0
1-1/2	1750	575	3	2-1/2	15.6	15.6	15.6	3.4	12.8
2	1750	200	1	2-3/4			-	15.5	25.2
2	1750	230	1	2-3/4	2.2	14.9	-	13.5	24.0
2	1750	200	3	2-1/2	2.7	2.7	2.7	10.4	36.8
2	1750	230	3	2-1/2	3.1	3.1	3.1	9.0	32.0
2	1750	460	3	2-1/2	12.5	12.5	12.5	4.5	16.0
2	1750	575	3	2-1/2	15.6	15.6	15.6	3.6	12.8
3	1750	230	1	3	1.36	5.55	-	20.0	45.5
3	1750	200	3	3	1.9	1.9	1.9	15.0	48.3
3	1750	230	3	3	2.2	2.2	2.2	13.5	42.0
3	1750	460	3	3	8.8	8.8	8.8	6.8	21.0
3	1750	575	3	3	11.0	11.0	11.0	5.5	16.8

MYERS LIMITED WARRANTY

F.E. MYERS warrants that its products are free from defects in material and workmanship for a period of 12 months from the date of installation or 18 months from the date of manufacture, whichever occurs first.

During the warranty period, and subject to the conditions hereinafter set forth, F.E. MYERS will repair or replace to the original user or consumer parts which prove defective due to defective materials or workmanship of MYERS. This remedy is exclusive and is the only remedy available to any person with respect to such MYERS product. Contact your nearest authorized MYERS distributor or MYERS for warranty service. At all times MYERS shall have and possess the sole right and option to determine whether to repair or replace defective equipment, parts or components.

Start-up reports and electrical system schematics may be required to support warranty claims. This warranty is effective only if MYERS supplied or authorized control panels are used.

LABOR, ETC. COSTS: MYERS shall IN NO EVENT be responsible or liable for the cost of field labor or other charges incurred by any customer in removing and/or reaffixing any MYERS product, part or component thereof.

THIS WARRANTY WILL NOT APPLY: (a) to defects or malfunctions resulting from failure to properly install, operate or maintain the unit in accordance with printed instructions provided; (b) to failures resulting from abuse, accident, or negligence; (c) to normal maintenance services and the parts used in connection with such service; (d) to units which are not installed in accordance with applicable codes, ordinances and good trade practices; or (e) if the unit is moved from its original installation location, and (f) unit is used for purposes other than for what it was designed and manufactured.

RETURN OR REPLACED COMPONENTS: any item to be replaced under this Warranty must be returned to MYERS at Ashland, Ohio, or such other place as MYERS may designate, freight prepaid.

PRODUCT IMPROVEMENTS: MYERS reserves the right to change or improve its products or any portions thereof without being obligated to provide such a change or improvement for units sold and/or shipped prior to such change or improvement.

WARRANTY EXCLUSIONS: as to any specific MYERS product, after the expiration of the time period of the warranty applicable thereto as set forth above. THERE WILL BE NO WARRANTIES, INCLUDING ANY IMPLIED WARRANTIES OF MERCHANTABILITY OR FITNESS FOR ANY PARTICULAR PURPOSE.

Some states do not allow limitations on how long an implied warranty lasts, so the above limitation may not apply to you. No warranties or representations at any time made by any representative of MYERS shall vary or expand the provisions hereof.

LIABILITY LIMITATION: IN NO EVENT SHALL MYERS BE LIABLE OR RESPONSIBLE FOR CONSEQUENTIAL, INCIDENTAL OR SPECIAL DAMAGES RESULTING FROM OR RELATED IN ANY MANNER TO ANY MYERS PRODUCT OR PARTS THEREOF.

Some states do not allow the exclusion or limitation of incidental or consequential damages, so the above limitation or exclusion may not apply to you.

This Warranty gives you specific legal rights and you may also have other rights which vary from state to state.

Direct all notices, etc. to: Warranty Service Department, F.E. Myers, 1101 Myers Parkway, Ashland, Ohio 44805.

Myers®

F.E. Myers, 1101 Myers Parkway, Ashland, Ohio 44805-1969

419/289-1144, FAX: 419/289-6658

www.industry.net/fe.myers