

Myers®

Pentair Pump Group

SX50/SX50H Explosion Proof Sump Pumps Safety Instructions Installation and Service Manual

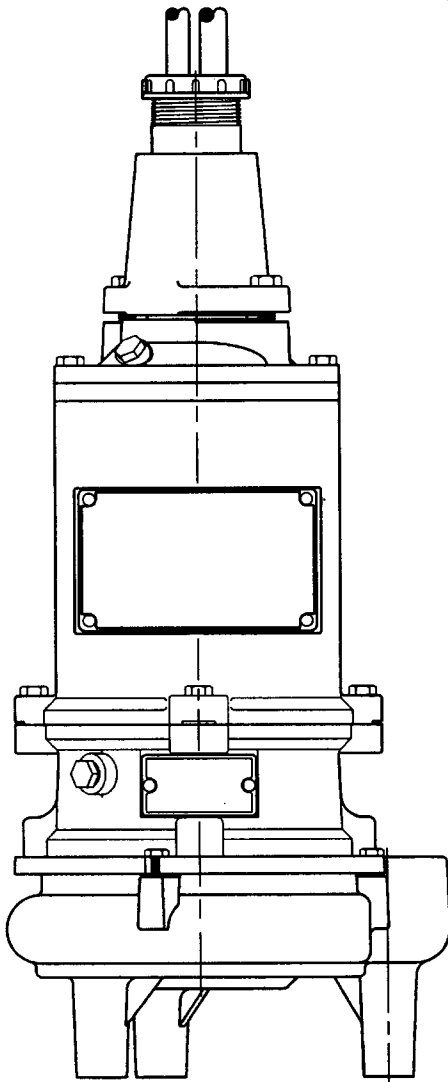

Class 1, Div. 1
Group D



Class 1, Div. 1
Group D

WARNING! IMPORTANT SAFETY INSTRUCTIONS! READ CAREFULLY BEFORE INSTALLATION. This manual contains important information for the safe use of this product. Read this manual completely before using this product and refer to it often for continued safe product use. **DO NOT THROW AWAY OR LOSE THIS MANUAL.** Keep it in a safe place so that you may refer to it often.

GENERAL

1. Most accidents can be avoided by using **COMMON SENSE.**
2. Read the operation and maintenance instructions manual supplied with the pump.
3. Do not wear loose clothing that can become entangled in the impeller or other moving parts.
4. This pump is designed to handle materials which could cause illness or disease through direct exposure. Wear adequate protective clothing when working on the pump or piping.

ELECTRICAL

- ▲5. To reduce the risk of electrical shock, pump must be properly grounded in accordance with the National Electric Code and all applicable state and local codes and ordinances.
- ▲6. To reduce risk of electrical shock, disconnect the pump from the power source before handling or servicing.
- ▲7. Any wiring to be done on pumps should be done by a qualified electrician.
- ▲8. Never operate a pump with a power cord that has frayed or brittle insulation.
- ▲9. Never let cords or plugs lay in water.
- ▲10. Never handle connected power cords with wet hands.

PUMPS

- ▲11. Pump builds up heat and pressure during operation, allow time for pump to cool before handling or servicing.
- ▲12. Only qualified personnel should install, operate or repair pump.
- ▲13. Keep clear of suction and discharge openings. **DO NOT** insert fingers in pump with power connected.
- ▲14. Do not pump hazardous material not recommended for pump (flammable, caustic, etc.).
- ▲15. Make sure lifting handles are securely fastened each time before lifting.
- ▲16. Do not lift pump by the power cord.
- ▲17. Do not exceed manufacturers recommendation for maximum performance, as this could cause the motor to overheat.
- ▲18. Secure the pump in its operating position so it can not tip over, fall or slide.
- ▲19. Keep hands and feet away from impeller when power is connected.

- ▲20. Submersible sump pumps are not approved for use in swimming pools, recreational water installations, decorative fountains or any installation where human contact with the pumped fluid is common.
- ▲21. Do not operate pump without safety devices in place.
- ▲22. For hazardous locations, use pumps that are listed and classified for such locations.

IMPORTANT! Myers is not responsible for losses, injury or death resulting from a failure to observe these safety precautions, misuse or abuse of pumps or equipment.

GENERAL INFORMATION

Pump Models: These instructions cover the installation and service of the Myers SX50 and SX50H series submersible sump pumps. The models are UL listed explosion proof for hazardous sewage locations Class 1, Div. 1, Group D.

Motor HP & Voltages: The SX50/SX50H sump pumps are offered in single and three phase up to ½ HP. Voltages will vary according to the application and can be seen in the tables in this manual.

Electrical Controls: All of these pump models must be used with a control panel. Myers built control panels are designed to supply the correct electrical controls, motor starting equipment and include the circuitry for moisture and heat sensors. It is recommended that a Myers built control panel be used so that all warranties apply.

General Construction: The SX50/SX50H motor construction is designed to meet Underwriters Laboratory requirements for Class 1, Group D sewage applications. These models are certified and nameplated with this approval. A cross sectional view of the internal workings of the pumps can be seen on pages 7 & 8. The motor chamber and seal chamber are filled with a high dielectric type oil for improved lubrication and heat transfer of the bearings and motor. Since the bearings have been designed for 50,000 hours of life, the oil should never require replacement under normal operating conditions. An air space above the oil level in both the

seal and motor chambers is provided to allow for the expansion of the oil when at operating temperature. The power and control lines are sealed and strain relieved on the outside entrance with a standard cord grip, and internally through the use of a dielectric potting resin surrounding the electrical wires.

Internal connection wiring diagrams are shown in Figure 8. All of the pump fasteners and shafts are made from corrosion resistant stainless steel, while the pump castings are made of ASTM A-48 Class 30 cast iron, and the multi-vane vortex impellers are made from Class 20 cast iron.

General Installation: Various configurations and methods of plumbing this series of sump pumps may be used.

Note: If the SX50/SX50H explosion proof pumps are used in conjunction with a rail lift-out system, it must be a U.L. approved non-sparking, explosion proof system.

IMPORTANT: If the following guidelines are not followed, the U.L. Explosion Proof approval is void.

Explosion Proof Service: These pumps are to be used for handling septic tank effluent, sewage, and storm water only. **Do not** use in other hazardous locations. These motors must be repaired and serviced only at a Myers Authorized Service Center or at the Myers Factory. Any unauthorized field repair voids warranty and the explosion proof rating.

CAUTION: After the pump is installed and sewage has entered the basin there is "Danger". Sewage water gives off methane and hydrogen sulfide gases, which are poisonous. Never enter a wet well unless the cover is open for a sufficient period of time to allow fresh air into the basin. It is recommended that a man in the basin have a harness on with a rope to the surface, so that he can be pulled out in case of asphyxiation. It is for this reason that Myers recommends using the rail lift-out system so that no service is required inside the basin.

Motor: Each motor is provided with heat sensor thermostats attached directly to the motor windings. The thermostats open if the motor windings see excessive heat and, in turn, open the motor contactor in the control panel, breaking the power to the pump. When the motor is stopped due to an overheat condition, it will not start until the motor has cooled and the heat sensor reset button is manually pushed on the front of the Myers control panel. This circuitry is provided in the Myers control panel designs.

The SX50/SX50H pumps are equipped with internal thermostats. The SX50/SX50H models are designed to meet Class B heat rise of 266°F (130°C).

Note: Failure to use proper circuitry and to connect the motor overheat protection in the control panel would negate all warranties and U.L. Listings.

Motor Seal Failure Warning: The seal chamber is oil filled and provided with moisture sensing probes to detect water leakage through the lower shaft seal. The probes can also detect moisture present in the upper motor housing.

The presence of water energizes a red seal leak warning light at the control panel. This is a warning light only, and does not stop the motor. It indicates a leak has occurred and the pump must be repaired. Normally, this indicates the outboard seal has leaked. Allowing the unit to operate too long after the warning could cause upper seal leakage along with motor failure.

The resistance across the moisture sensing (seal failure) probes, should be checked after a seal leak warning light has lit. This can be done by disconnecting the red and orange control wires from the control panel, and measuring the resistance with an ohm meter between the wires. For an explosion proof pump the reading should be above 30,000 ohms. If the measured values are below those indicated above, the pump may have a lower seal failure and require service.

On the Myers explosion proof control panels the seal leak test switch tests the seal leak circuit continuity. When pushed the seal leak test bulb should light. If the test bulb does not light it means either the wiring circuitry to the seal leak probes has been broken or the bulb has burned out.

Note: Myers built control panels supply the correct circuitry for moisture and heat sensor connections. Failure to install the correct circuitry with proper connection would negate warranty and UL Listing. See Figure 7.

Motor Power Cord, Control Cord and Cord Cap Assembly: Each motor power cord has 4 conductors - white, black, red and green. For a single phase motor the black is connected to the common lead, the white is connected to the main lead, while the red is connected to the start circuitry, and the green is attached to a good ground. The rotation of a single phase pump is set properly at the factory.

For three phase motor, the black, white, and red conductors are power leads and the green is ground.

Note: Rotation should be clockwise when observed from the top of the pump. This can be checked by noting which direction the pump torques upon initial starting. A properly rotating pump will torque counterclockwise upon start.

ALWAYS CHECK THREE PHASE PUMPS FOR PROPER ROTATION BEFORE INSTALLING PUMPS.

The control cable has 5 conductors - black, white, red, orange and green. White and black connect to the heat sensor terminals in the control panels; red and orange connect to the seal failure terminals in the control panel; and the green connects to the ground in the control panel.

The cord cap is epoxy potted. This allows the cord cap, with cords, to be removed from the motor. With this arrangement, the cords can be permanently installed in a sealed fitting in the sump. This should be an approved explosion proof junction box for hazardous locations. **The control and power cables cannot be spliced!**

Note: Each cable has a green ground wire and must be properly grounded per the National Electric Code and local codes.

Electrical Motor Controls: All electrical controls and motor starting equipment should be as specified in these instructions. Consult factory for any acceptable alternates. For Hazardous locations the controls and control panel must be installed outside the hazardous area. Approved explosion proof controls that are intrinsically safe must be used.

Junction Box: If a junction box is used in a hazardous location, it must be an explosion proof approved type with explosion proof cord connectors. Wires from the junction box must pass through an explosion proof seal connector.

Level Sensing Controls: Intrinsically safe-type float controls are recommended for all applications and required for explosion proof service. An intrinsically safe control panel relay will limit the current and voltage to the level controls. A Myers control panel can be supplied with this type circuitry.

The float level controls maintain the basin sewage water level by controlling pump turn-on and turn-off levels.

1. The lower turn-off control should be set so that the pump stops with the water covering the entire motor housing. Consult the factory for any settings below this point.
2. The upper turn-on control should be set above the lower turn-off control. The exact height between the two controls is determined by the number of pump starts desired and the depth of the basin. A maximum of 10 starts per hour should not be exceeded.
3. The override control is set at a specified height above the upper turn-on control.
4. The alarm control is set about 6" to 12" above the override control.
5. No control should be set above the inlet invert.

Electrical Connections: All electrical wiring must be in accordance with local code and only qualified electricians should make the installations. Complete wiring diagrams are included for use in making the installation. All wires should be checked for shorts to ground with an ohmmeter or meager after the connections are made. This is important, as one grounded wire can cause failure of the pump, control panel or personal injury.

Pump: The fluid end of the pump is field serviceable and can be disassembled in case of wear, damage, plugging or outboard seal failure. The following will describe the disassembly and reassembly process.

WARNING! Disconnect pump from power source before servicing or handling.

Disassembly

1. With the pump located in a secure place, remove the bolts fastening the seal housing to the volute. The motor and impeller can now be removed as a unit.
2. Lay the unit down on its side. If the lower seal is to be removed, it is recommended that the oil in the seal chamber be drained. This can be done by removing the lower seal chamber plug and draining the oil into a holding container.
3. Using a proper wrench, the impeller retaining nut must be removed. This may require a piece of wood placed between the vanes to keep the impeller from rotating while removing the nut.

Loctite™ is used on this bolt and heating to 450-500°F may also be required to loosen. The impeller is mounted on a threaded shaft. To remove impeller, rotate impeller with one hand, while holding pump shaft with screwdriver.

4. If the lower seal needs removed, first remove the compression spring that rides between the impeller and the seal assembly. Next take a pair of screwdrivers and remove the compression ring that surrounds the rubber bellows on the rotating portion of the seal assembly. Again using the screwdrivers, pry the remaining portion of the rotating seal assembly off the shaft. The ceramic stationary can be removed by placing a screwdriver between the rubber and the ceramic face, and then prying, working around the entire diameter. Note, these parts should be discarded and a new seal assembly installed.
5. If the oil in the seal chamber was drained, examine the contents to determine if the upper seal has been damaged. Signs of grit or other abrasive material may indicate that the upper seal has also been damaged. Pressurizing the motor housing assembly between 7 and 10 PSI and observing any drop in pressure will indicate if the upper seal is functioning properly.

Note: Upper seal repairs must be done at a Myers authorized service center or at the Myers factory. Any unauthorized field repair voids warranty and the explosion proof approval on the U.L. Listed pumps.

Reassembly

1. Remove the ceramic portion of the new seal from the package. Brush new dielectric oil around the rubber portion of the stationary assembly and into the pocket in the seal housing. Note, keep the oil off the seal face. Without scratching the seal face, press the ceramic stationary portion into the seal

housing. A piece of PVC pipe that fits onto the face of the seal works well for installation. With clean cloth, lightly wipe the face of the seal surface to make sure it is dirt free. Remove the rotating portion of the seal from the package and lubricate the inside diameter of the rubber bellows and the outside diameter of the shaft. Place the seal over the shaft. Evenly press on the body of the rotational assembly and slide it down the shaft until the seal faces meet. A PVC pipe with the inside diameter slightly larger than the shaft diameter can work well to press the rotational assembly into position. Once the seal assembly is in position, place the spring over the register on the rotational portion of the seal.

2. Thread the impeller onto the shaft, making sure that the seal spring is registered properly onto the back side of the impeller. Place the proper Loctite fluid on the impeller retaining nut. Tighten nut on shaft.
3. Fill the seal chamber with new dielectric oil. An air gap of 10-15% volume must be left for the expansion of the oil when it is at operating temperature.
4. The motor and impeller assembly can be installed into the volute, making sure that the units are aligned properly. Install the volute retaining bolts and tighten.
5. Air tends to trap in the pump case when water rises in the sump or when the pump is lowered into the water after service. To vent off this air a small hole is drilled into the volute casting. **Be sure this vent hole is clean after any service work on pump.** Air venting is not a problem after initial start.

SX50 DIMENSIONS
[Dimensions in mm]

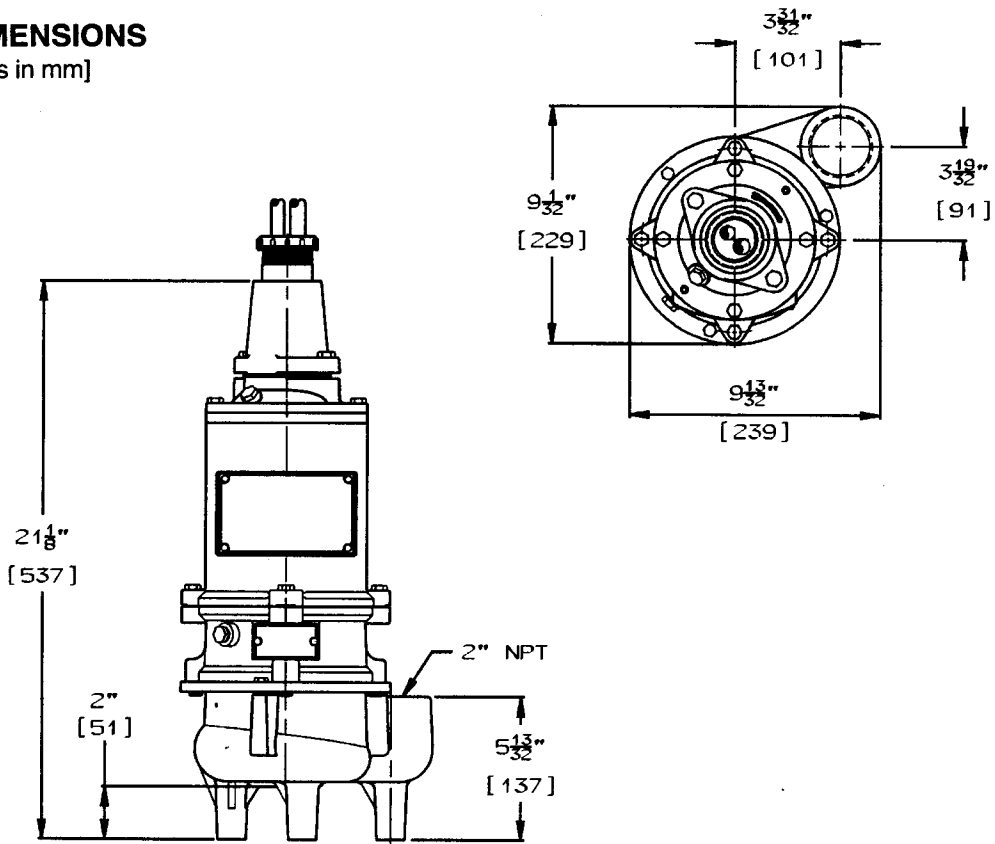

SX50H DIMENSIONS
[Dimensions in mm]

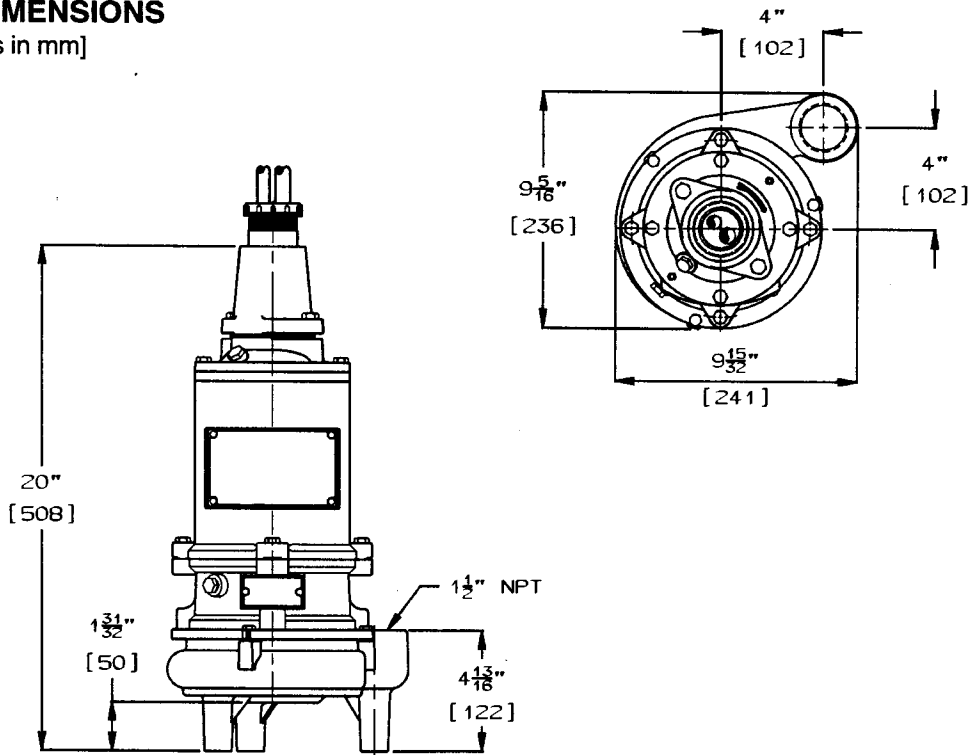

FIG. 1

SX50 PUMP PARTS

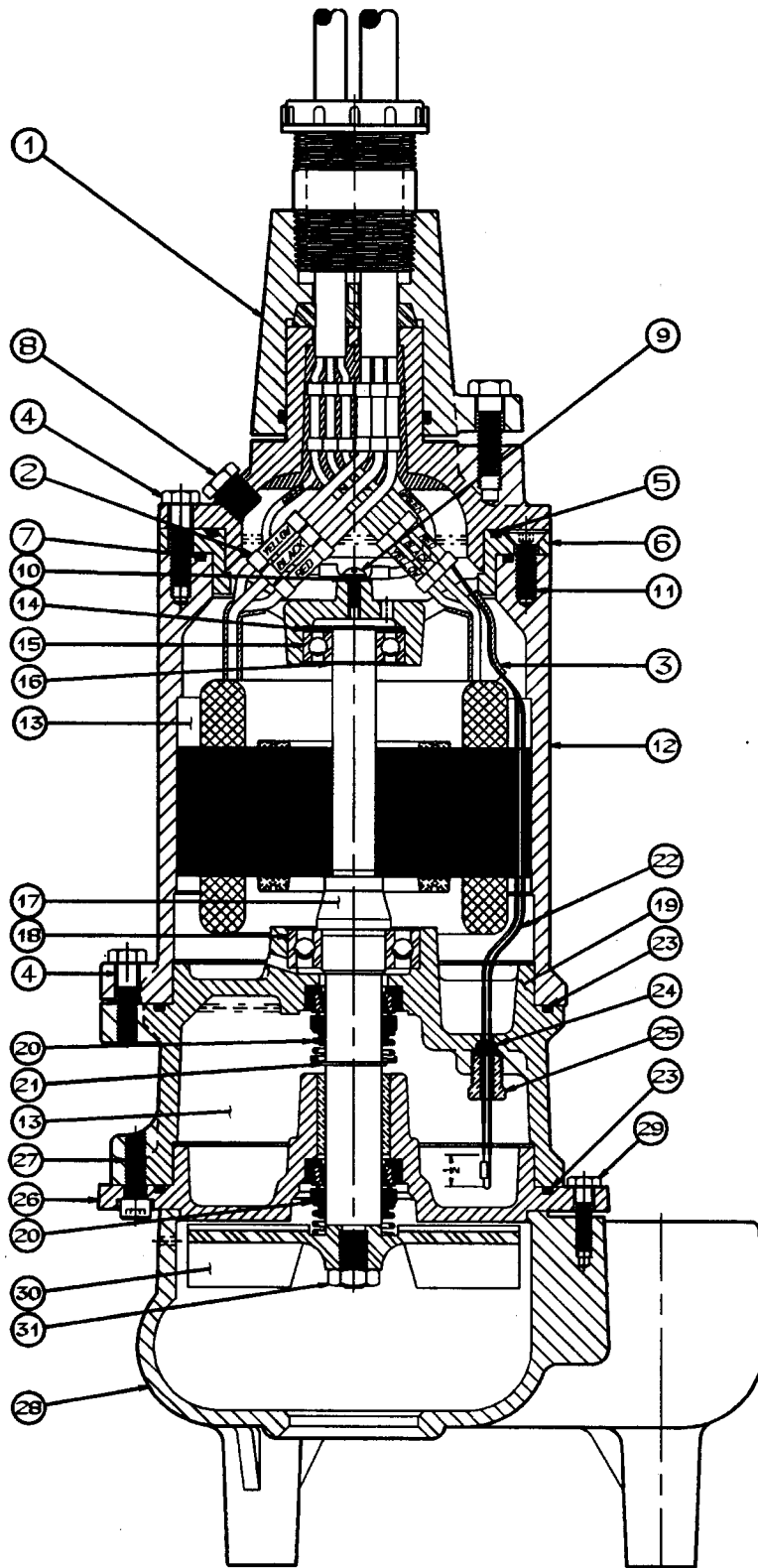

FIG. 2

SX50H PUMP PARTS

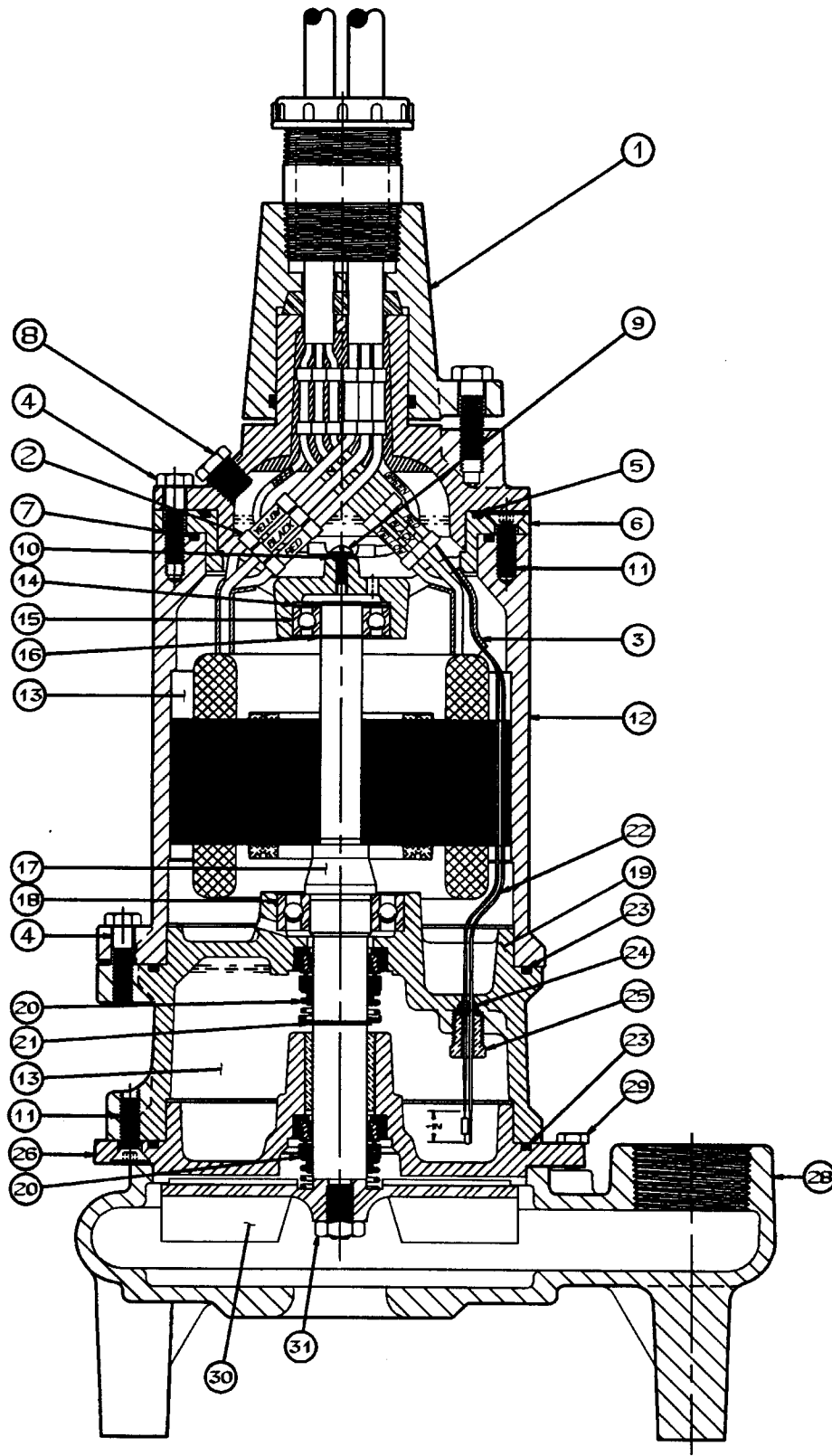

FIG. 3

SX50/SX50H PARTS LIST

Ref. No.	Description	Qty.	SX50	SX50H
1	Cap, Cord	1	22407C100	22407C100
2	Connector	7	12762A001	12762A001
3	Tube, Plastic x 1-1/4" Lg.	2	10649A102	10649A102
4	Screw, Cap 5/16 x 1-1/4" Lg.	8	19100A012	19100A012
5	O'Ring, 4-1/2" x 4-1/4" x 1/8"	1	05876A122	05876A122
6	Cap, Upper Bearing	1	21570B100	21570B100
7	O-Ring, 4-7/8" x 4-5/8" x 1/8"	1	05876A123	05876A123
8	Plug, Pipe 1/4" NPT	2	05022A054	05022A054
9	Screw, Mach. #10 x 1/2" Lg.	1	05434A034	05434A034
10	Washer, Lock	1	06107A015	06107A015
11	Screw, Mach. 5/16 x 1" Lg. (SX50)	2	07597A017	
11	Screw, Mach. 5/15 x 1" Lg. (SX50H)	6		07597A017
12	Housing w/Stator (1Ø)	1	21571D150K	21571D150K
	Housing w/Stator (3Ø) 230/460V	1	21571D152K	21571D152K
	Housing, Motor		21571D100	21571D100
	Stator Only (1Ø)		21656C103	21656C103
	Stator Only (3Ø) 230/460V	1	21656C106	21656C106
13	Oil, Transformer (1 gal. can)	1.06 gal.	11009A008K	11009A008K
14	Washer, Spring	2	19331A005	19331A005
15	Bearing, Ball (upper)	1	08565A013	08565A013
16	Ring, Retaining	1	11816A006	11816A006
17	Rotor w/Shaft (1Ø)	1	26859C101	26859C101
	Rotor w/Shaft (3Ø)	1	26859C104	26859C104
18	Bearing, Ball (lower)	1	08565A018	08565A018
19	Housing, Upper Seal	1	21574D100	21574D100
20	Seal, Shaft	2	21576A010	21576A010
21	Ring, Retaining	1	12558A006	12558A006
22	Electrode w/Resistor	1	22578A003	22578A003
23	O'Ring, 6-1/8" x 5-7/8" x 1/8"	2	05876A125	05876A125
24	Ferrule, Rubber	1	22579A000	22579A000
25	Plug, Special	1	21577A000	21577A000
26	Housing, Lower Seal	1	21578C110	21578C115
27	Screw, Cap 5/16 x 1" Lg.	4	06106A008	-----
28	Case, Volute	1	21612D000	26226D012
29	Screw, Cap 1/4 x 1" Lg.	3	19099A012	19099A012
30	Impeller, Recessed	1	21663C020	21663C010
31	Nut, Jam	1	19109A070	19109A070
32	Screw, Set	2	05013A027	05013A027

PERFORMANCE CURVE

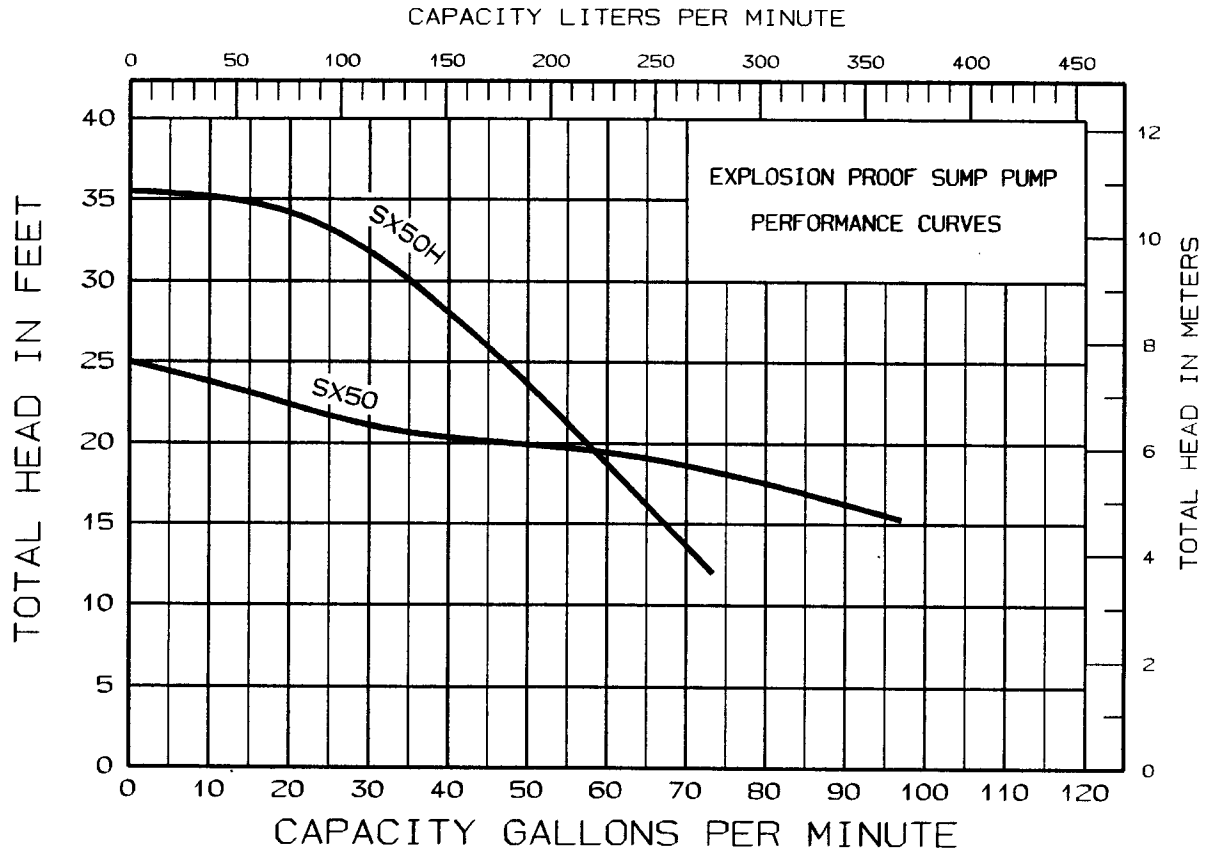

FIG. 4

Available Models	Motor Electrical Data								
	HP	Volts	Phase	Hz	Start Amps	Run Amps	Service Factor Amps	NEC Code Letter	Service Factor
Standard									
SX50-21	½	230	1	60	12.5	5.3	5.8	H	1.1
SX50H-21	½	230	1	60	12.5	5.3	5.8	H	1.1
SX50-23	½	230	3	60	10.8	3.2	4.0	G	1.25
SX50H-23	½	230	3	60	10.8	3.2	4.0	G	1.25

WIRING DIAGRAMS

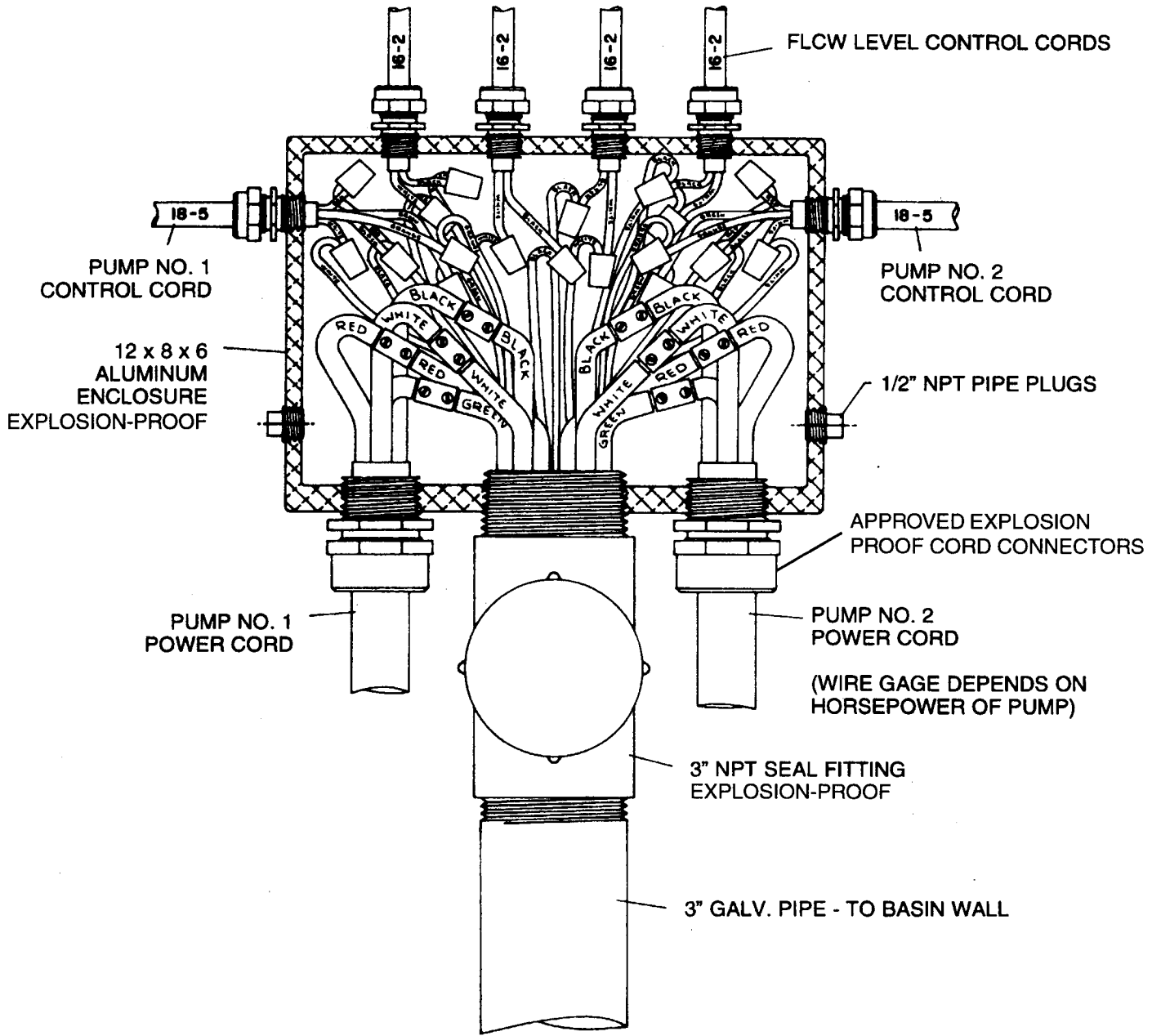
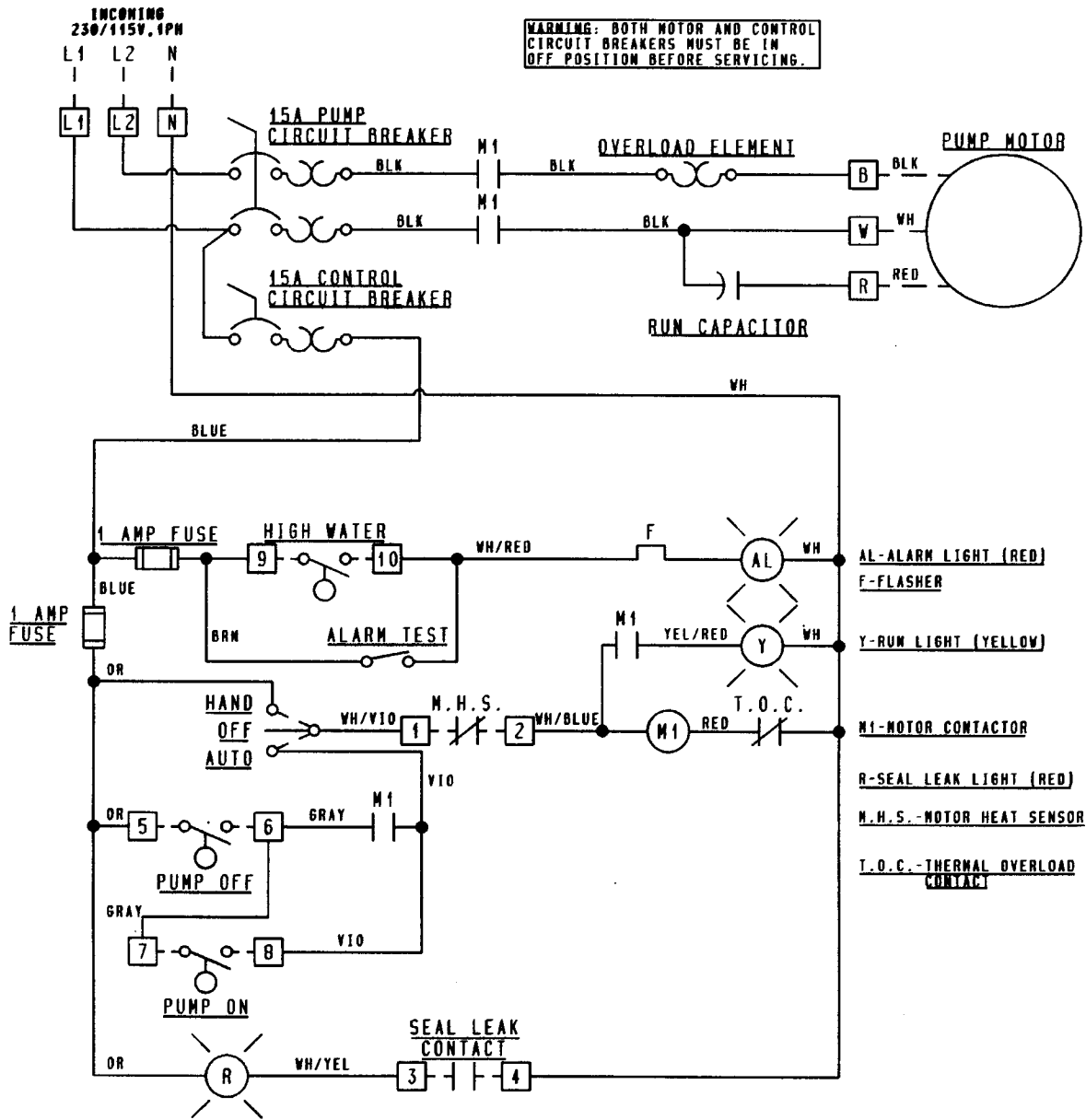

FIG. 6

WIRING SCHEMATIC FOR 230V, 1Ø SIMPLEX SYSTEM



TERMINAL BLOCK TORQUE REQUIREMENTS:
 L1, L2, N - 25 LB. IN.
 B, W, R - 8 LB. IN.
 1 THRU 10 - 8 LB. IN.
 USE COPPER WIRE WITH AN INSULATION TEMPERATURE RATING OF 60° C MIN.

FLOAT CONTROLS MUST BE RATED FOR 2 AMPS AT 115 VOLTS
NOTE: CONNECT ALL GREEN WIRES TO GROUND BAR

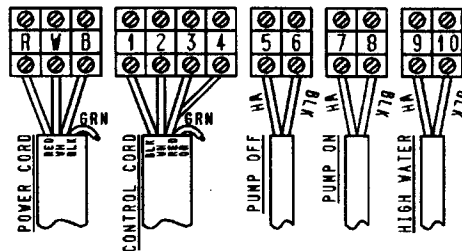

FIG. 7

WIRING DIAGRAM 230V, 1Ø

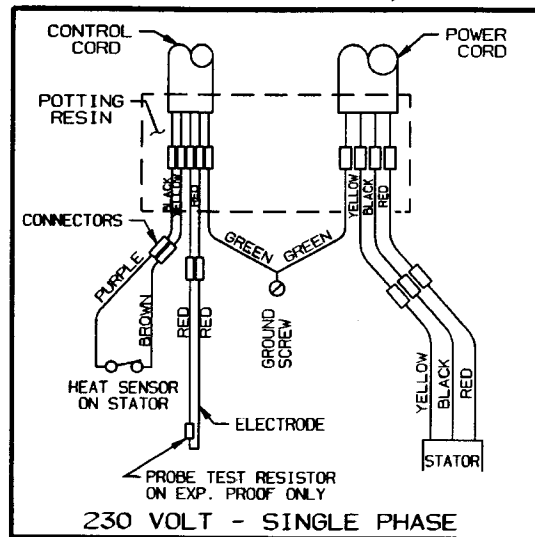
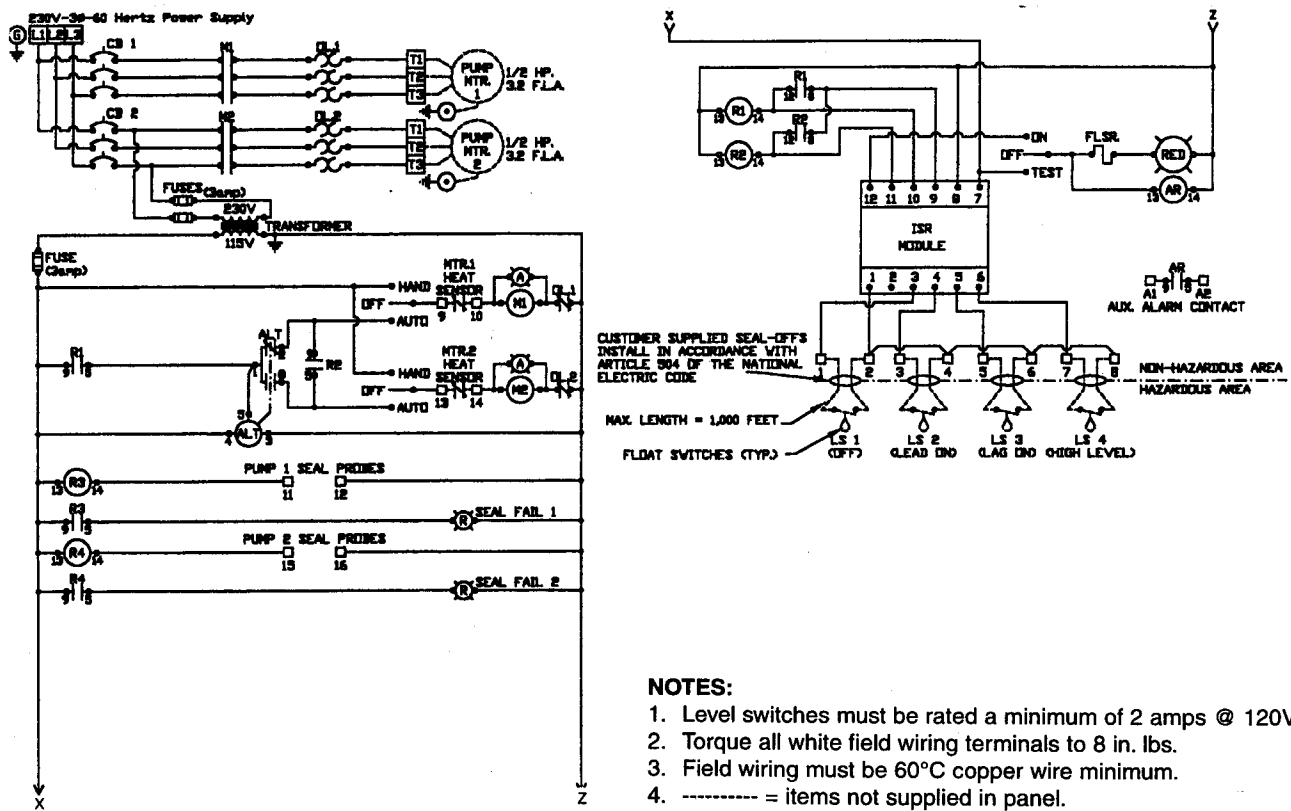
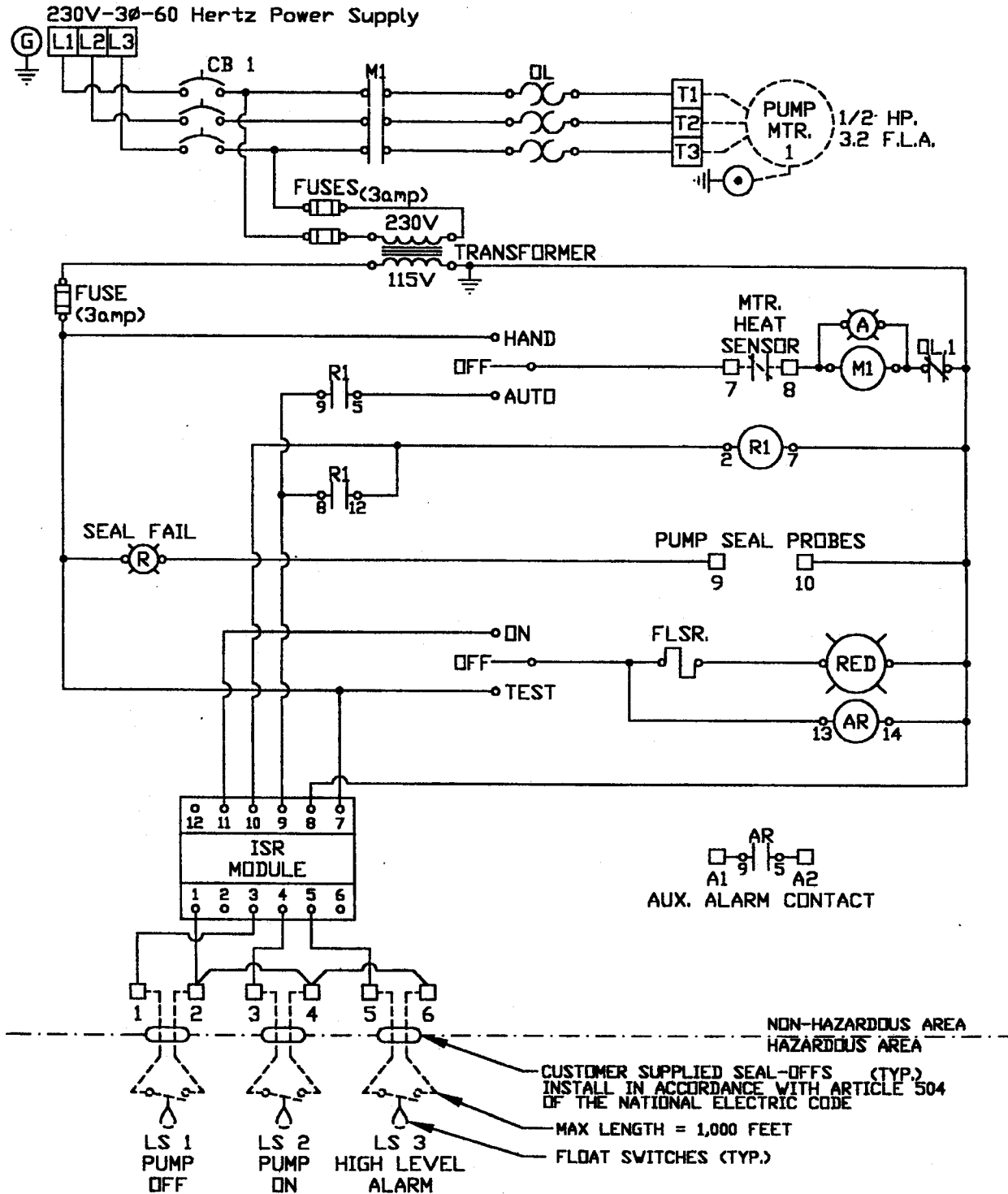

FIG. 8

WIRING SCHEMATIC FOR 230V, 3Ø DUPLEX SYSTEM



WIRING SCHEMATIC FOR 230V, 3Ø SIMPLEX SYSTEM



NOTES:

1. Level switches must be rated a minimum of 2 amps @ 120V.
2. Torque all white field wiring terminals to 8 in. lbs.
3. Field wiring must be 60°C copper wire minimum.
4. ----- = items not supplied in panel.

WIRING SCHEMATIC FOR 460V, 3Ø SIMPLEX SYSTEM

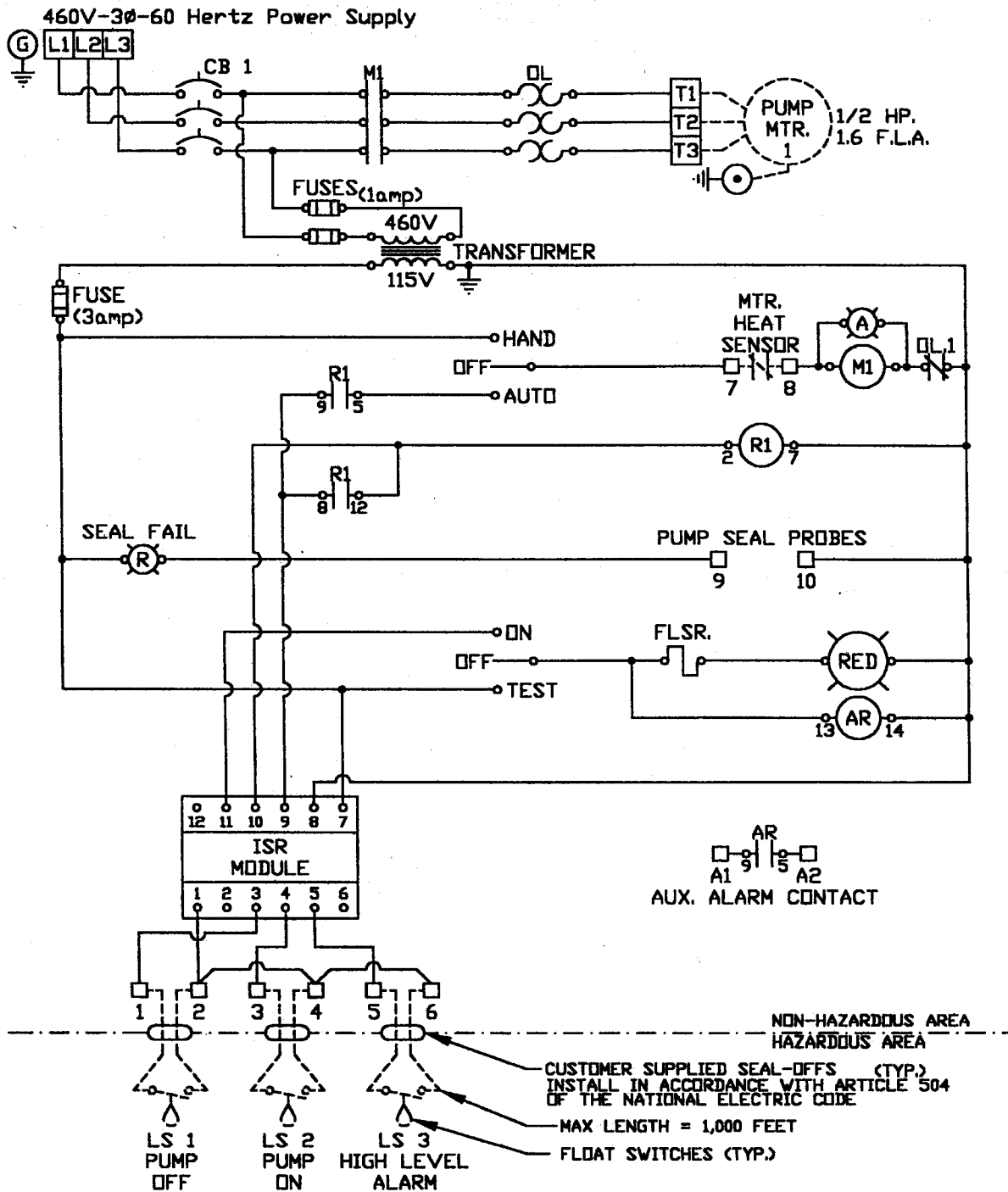

NOTES:

1. Level switches must be rated a minimum of 2 amps @ 120V.
2. Torque all white field wiring terminals to 8 in. lbs.
3. Field wiring must be 60°C copper wire minimum.
4. ----- = items not supplied in panel.

WIRING SCHEMATIC FOR 460V, 3Ø DUPLEX SYSTEM

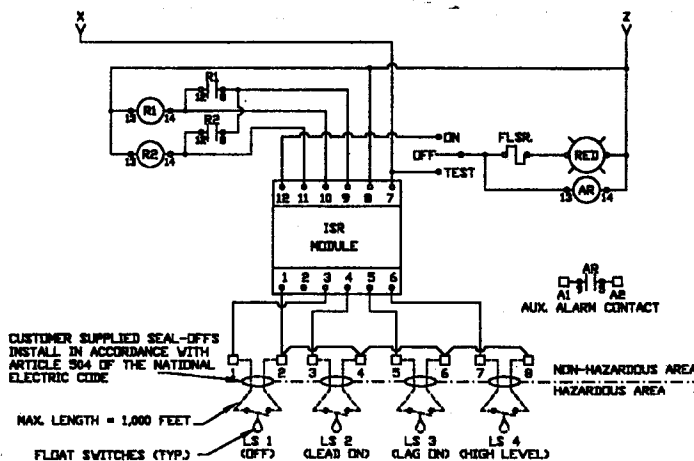
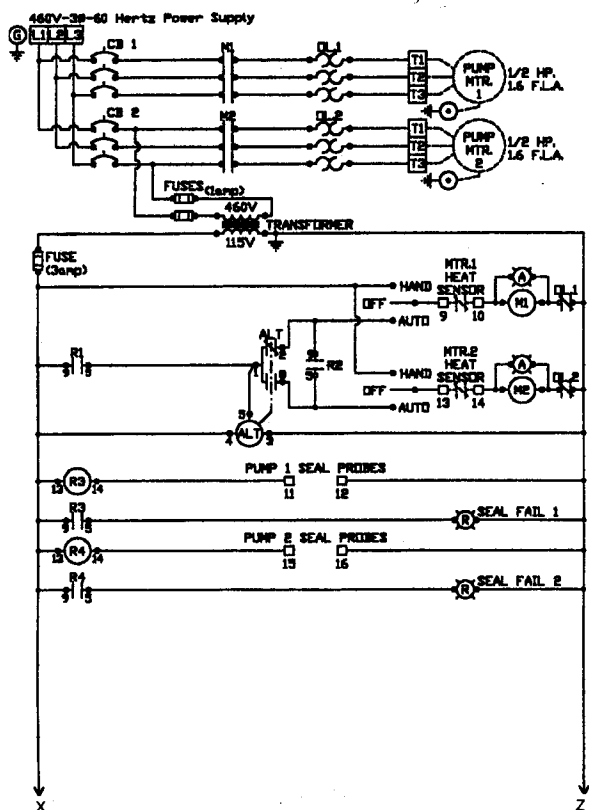

CUSTOMER SUPPLIED SEAL-OFFS
INSTALL IN ACCORDANCE WITH
ARTICLE 504 OF THE NATIONAL
ELECTRIC CODE

MAX. LENGTH = 1,000 FEET

FLOAT SWITCHES (TYP.)

NOTES:

1. Level switches must be rated a minimum of 2 amps @ 120V.
2. Torque all white field wiring terminals to 8 in. lbs.
3. Field wiring must be 60°C copper wire minimum.
4. ----- = items not supplied in panel.

CHECK LIST IF PUMP DOES NOT OPERATE PROPERLY

Checking for Moisture in Motor: Use an ohmmeter or a megger and set on highest scale. Readings on the large power cord between any of the conductors red, black or white to the green conductor or to the motor housing should be greater than 1,000,000 ohms (megaohm). A motor will probably run with a lower reading, but if the pump is out of service and the value of the reading is below 1,000,000 ohms (1 megaohm), the motor housing and stator should be removed and baked in a drying oven at 220°F. This service work should only be done at an authorized service station. **Note, readings should be taken with line leads disconnected from the control panel.**

Resistance of Windings: Every motor winding has a fixed resistance. The windings must check close to the values given in the tables to operate properly.

See the motor electrical data chart. Use an ohmmeter and set to the one ohm scale. Read the resistance with the motor leads disconnected from the pump control panel.

CONDITION**PROBABLE CAUSE**

Red Light comes on at control box.

This indicates some water has leaked past the lower seal and has entered the seal chamber and made contact with the electrode probe. Pump must be removed for replacement of lower seal. This preventative repair will save an expensive motor.

Overload trips at control box and alarm buzzer or flashing red light comes on due to high water level in basin.

1. Push in on red reset button to reset overload. If overload trips again after short run, pump has some damage and must be removed from basin for checking.
2. Trouble may be from clogged impeller causing motor to overload or could be from failed motor.
3. Trouble may be from faulty component in control box. Always check control box before removing pump.

Yellow run light stays on continuously.

1. Indicates H-O-A switch may be in the hand position.
2. Level control switch may have failed causing pump to continue to operate when water is below lower control.
3. Impeller may be partially clogged causing pump to operate at very reduced capacity.
4. Gate valve or check valve may be clogged causing low pump flow.
5. Pump may be air locked.

Circuit breaker trips.

1. Reset breaker by pushing completely down on handle then back to on position. If breaker trips again in few seconds it indicates excessive load probably caused by a short in the motor or control box. Check out instructions given with control box before pulling pump.
2. If this condition happens after an electrical storm, motor or control box may be damaged by lightning.
3. Resistance reading of the motor with lead wires disconnected from the control box can determine if trouble is in motor or control box.

Pump is noisy and pump rate is low.

1. Impeller may be partially clogged with some foreign objects causing noise and overload on the motor.

Grease and solids have accumulated around pump and will not pump out of basin.

1. Lower control switch may be set too high.
2. Run pump on hand operation for several minutes with small amount of water running into basin to clean out solids and grease. This allows pump to break suction and surge which will break up the solids. If level switch is set properly this condition generally will not occur.
3. Trash and grease may have accumulated around floats causing pump to operate erratically.

IMPORTANT - Pump should be thoroughly cleaned of trash and deposits before starting disassembly operations.

CAUTION - DISCONNECT ALL POWER AND CONTROL WIRES TO MOTOR AT CONTROL PANEL BEFORE STARTING DISASSEMBLY OPERATIONS. NEVER RELY ON OPENING CIRCUIT BREAKER ONLY.

MYERS LIMITED WARRANTY SUMP & RESIDENTIAL SEWAGE

During the time periods and subject to the conditions hereinafter set forth, **F. E. Myers** will repair or replace to the original user or consumer any portion of your new **MYERS product which proves defective due to defective materials or workmanship of MYERS**. Contact your nearest Authorized **MYERS Dealer** for warranty service. At all times **MYERS** shall have and possess the sole right and option to determine whether to repair or replace defective equipment, parts, or components. Damage due to lightning or conditions beyond the control of **MYERS** is NOT COVERED BY THIS WARRANTY.

WARRANTY PERIOD

Pumps: 12 months from date of purchase or 18 months from date of manufacture.

Labor, etc. Costs: **MYERS** shall IN NO EVENT be responsible or liable for the cost of field labor or other charges incurred by any customer in removing and/or reaffixing any **MYERS** product, part or component thereof.

THIS WARRANTY WILL NOT APPLY: (a) to defects or malfunctions resulting from failure to properly install, operate or maintain the unit in accordance with printed instructions provided; (b) to failures resulting from abuse, accident or negligence; (c) to normal maintenance services and the parts used in connection with such service; (d) to units which are not installed in accordance with applicable local codes, ordinances and good trade practices; or (e) unit is used for purposes other than for what it was designed and manufactured, and (f) if three phase submersible motors are installed on a single phase power supply using a phase converter or if three phase power is supplied by only two transformers, making an open Delta system.

RETURN OR REPLACED COMPONENTS: any item to be replaced under this Warranty must be returned to **MYERS** in Ashland, Ohio, or such other place as **MYERS** may designate, freight prepaid.

PRODUCT IMPROVEMENTS: **MYERS** reserves the right to change or improve its products or any portions thereof without being obligated to provide such a change or improvement for units sold and/or shipped prior to such a change or improvement.

WARRANTY EXCLUSIONS: **MYERS** SPECIFICALLY DISCLAIMS THE IMPLIED WARRANTIES OF MERCHANTABILITY AND FITNESS FOR A PARTICULAR PURPOSE AFTER THE TERMINATION OF THE WARRANTY PERIOD SET FORTH HEREIN.

Some states do not permit some or all of the above warranty limitations and, therefore, such limitations may not apply to you. No warranties or representations at any time made by any representatives of Myers shall vary or expand the provision hereof.

LIABILITY LIMITATION: IN NO EVENT SHALL **MYERS** BE LIABLE OR RESPONSIBLE FOR CONSEQUENTIAL, INCIDENTAL OR SPECIAL DAMAGES RESULTING FROM OR RELATED IN ANY MANNER TO ANY **MYERS** PRODUCT OR PARTS THEREOF. PERSONAL INJURY AND/OR PROPERTY DAMAGE MAY RESULT FROM IMPROPER INSTALLATION. **MYERS** DISCLAIMS ALL LIABILITY, INCLUDING LIABILITY UNDER THIS WARRANTY, FOR IMPROPER INSTALLATION -- **MYERS** RECOMMENDS FOLLOWING THE INSTRUCTIONS IN THE INSTALLATION MANUAL. WHEN IN DOUBT, CONSULT A PROFESSIONAL.

Some states do not allow the exclusion or limitation of incidental or consequential damages, so the above limitation or exclusion may not apply to you.

This Warranty gives you specific legal rights and you may also have other rights which vary from state to state.

In the absence of suitable proof of this purchase date, the effective date of this warranty will be based upon the date of manufacture.

DETERMINATION OF UNIT DATE OF MANUFACTURE: Submersible Sump pump (8-95) month and year stamped on pump nameplate; column sump pump month and year on red warranty tag.

Myers

Festair Pump Group

F. E. Myers, 1101 Myers Parkway, Ashland, Ohio 44805
419-289-1144 • Fax 419-289-6658 • www.femyers.com