

WHR/WHRH and WHRE Waste Handling Sump Pumps

INSTALLATION AND SERVICING
INSTRUCTIONS FOR MYERS
WHR/WHRH AND WHRE
SUBMERSIBLE SUMP PUMPS
SINGLE & THREE PHASE POWER
SINGLE & DOUBLE SEAL

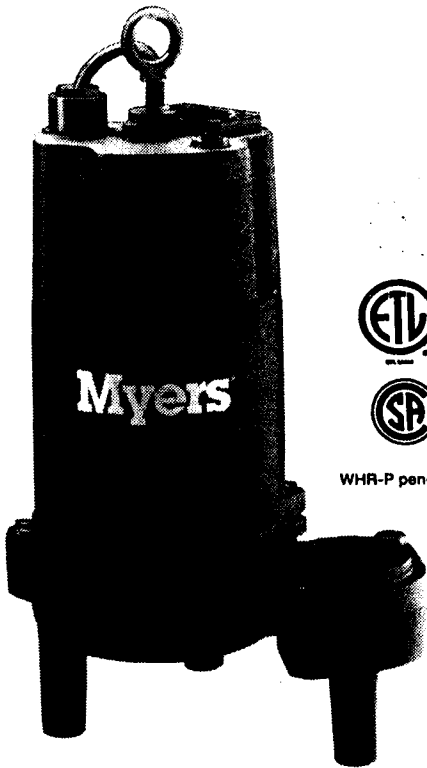

SINGLE SEAL PUMPS



WHR-P pending

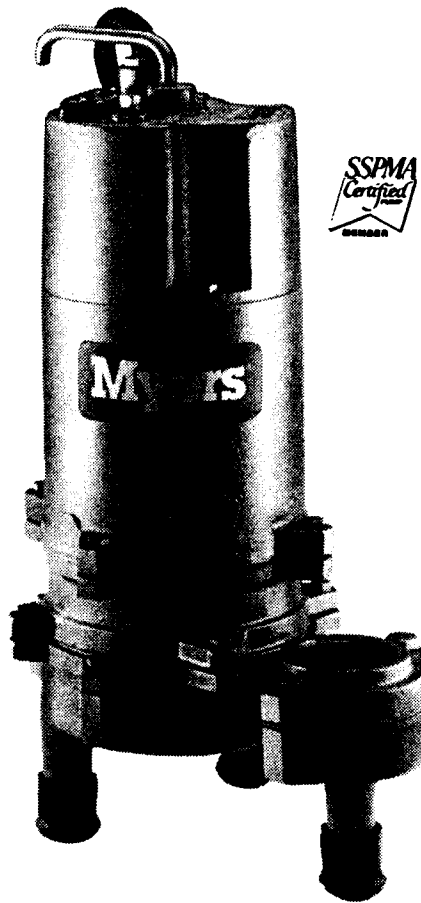

DOUBLE SEAL PUMPS



(Except double seal pumps with seal leak probe)

**TYPICAL SECTIONAL DRAWINGS
FOR WHR/WHRH AND WHRE
SINGLE AND DOUBLE SEAL
WASTE HANDLING PUMPS**

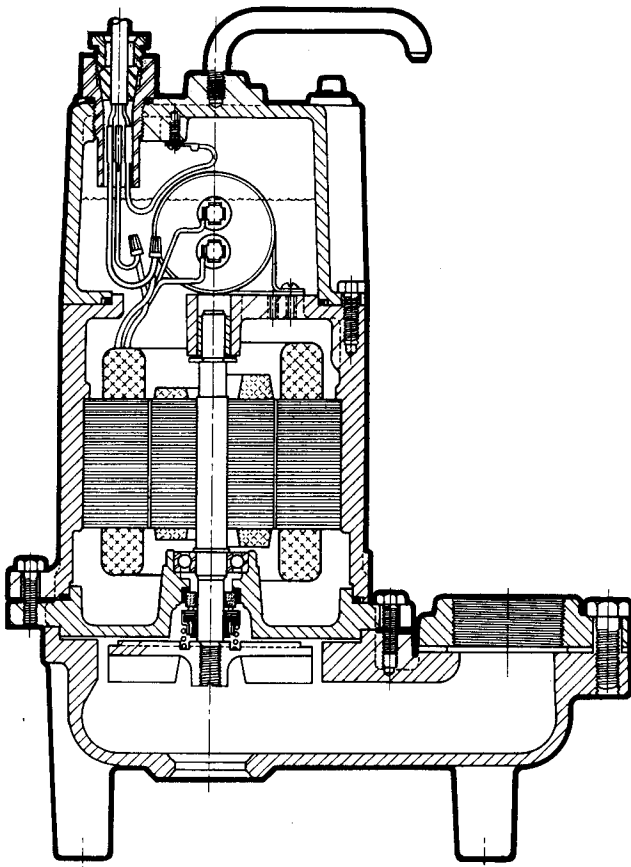

**SINGLE SEAL
FIG. 1**

WHR
WHRH
WHRE

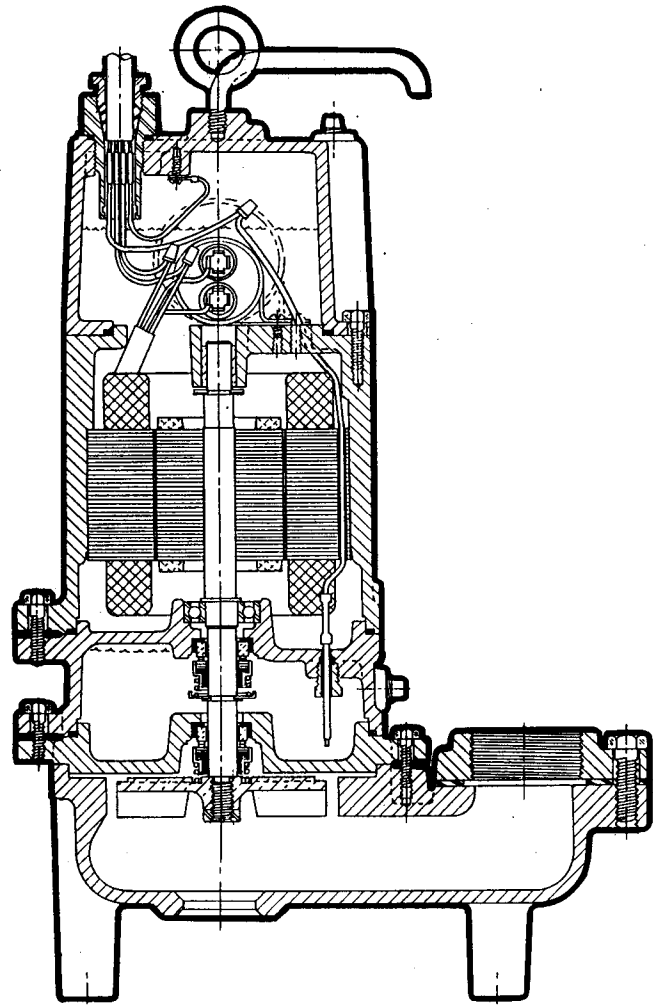

**DOUBLE SEAL
FIG. 2**

WHR-DS WHR-DS L/D
WHRH-DS WHRH-DS L/D
WHRE-DS WHRE-DS L/D

GENERAL DESCRIPTION AND USES

The WHR and WHRH Series are solids handling pumps that can be used to pump RAW SEWAGE for COMMERCIAL and DOMESTIC use, but are not intended to handle large rags, mop heads or strings. All pumps can be used for normal sump duty where extra capacity is required.

The WHRE Series is for pumping sump water and EFFLUENT from septic tanks only. DO NOT USE FOR RAW SEWAGE.

RECESSED IMPELLERS

All of the pumps are of the recessed impeller type that provides a clear volute passage for solids as no solids pass through the impeller.

All of the pumps listed can be used to pump septic tank EFFLUENT or GROUND sewage as used in some pressure sewer systems.

DESIGN OF PRESSURE SEWER SYSTEMS

MYERS has available complete computer SOFTWARE for designing PRESSURE SEWER SYSTEMS. This gives pipe sizes to use and gives exact flow from any pump or group of pumps in the system when operating simultaneously.

This design DISK for IBM or COMPATIBLE computers is available to engineers on request.

DOUBLE SEAL PUMPS

All double seal models have two seals with an oil chamber between the seals so that seal faces of both lower and upper seals are oil lubricated for longer life and greater protection against water leaking into the motor windings. These double seal units are made with and without a seal leak probe. The leak probe in the oil seal chamber detects any water leakage into the chamber and turns on a red signal light in the control panel. Pumps should be removed from sump and seals replaced after seal light shows in the panel. Control panels must be used for pumps having the seal leak probe.

Double seal pumps without the seal leak probe, should be pulled and seal leak checked in 12 to 18 months.

LEVEL CONTROLS

All pumps must use sealed level control switches for automatic operation. MLC and MFLC controls have sealed mercury switches that are 1 H.P. rated at 230 volts. ALC and AWS-1 controls have sealed mechanical switches that are rated 2 H.P. at 230 volts.

Simplex single phase pumps can be made automatic by attaching MFLC or MLC controls to

pump. These switches have a fixed draw off level of 8 to 10" and can be used up to 1 H.P. For higher H.P. ratings two mercury switch (or SMNO) controls with a magnetic starter can be used.

The ALC and AWS-1 controls can be used for simplex single phase pumps with ratings up to 2 H.P.

All duplex systems must use pilot mercury control sensor switches with control box and magnetic starters.

Plug in cords can be used on all the single phase pumps without seal leak detector. This cord has a GROUND pin that plugs into a grounded receptacle. The grounded receptacle cannot be used in the wet sump or basin due to DANGER of current leakage.

Sealed junction boxes must be used in wet sumps or basins to make connections to motor cord. The AWS-1 control also acts as a sealed junction box for connecting power cord to pump cord.

SAFETY WARNING

All pumps single or three phase must have a GROUND WIRE that is connected to a screw in the metal pump housing. This wire goes to the control box and is connected to a good outside GROUND such as a metal water pipe or GROUND STAKE driven at least 6 feet into the ground.

MOTOR TYPES

All single phase pump motors are of the permanent split capacitor type that do not require a start switch or start relay.

Automatic reset overload switches are attached directly to the motor windings.

Three phase pump motors require a magnetic starter with 3 leg overload protection.

UL and CSA APPROVAL

All manual single seal pumps and double seal pumps without a seal probe sensor are UL listed. All single and double seal pumps are CSA listed. Myers is a SSPMA certified pump member.

INSTALLATION

Pumps can be installed in inside sealed basins with proper venting for either simplex or duplex systems. SIMPLEX or DUPLEX basin systems are available. See Figs. 3 and 4.

It is not recommended that basins be used for RAW SEWAGE inside the home, but are for use in office buildings and small industrial buildings and factories.

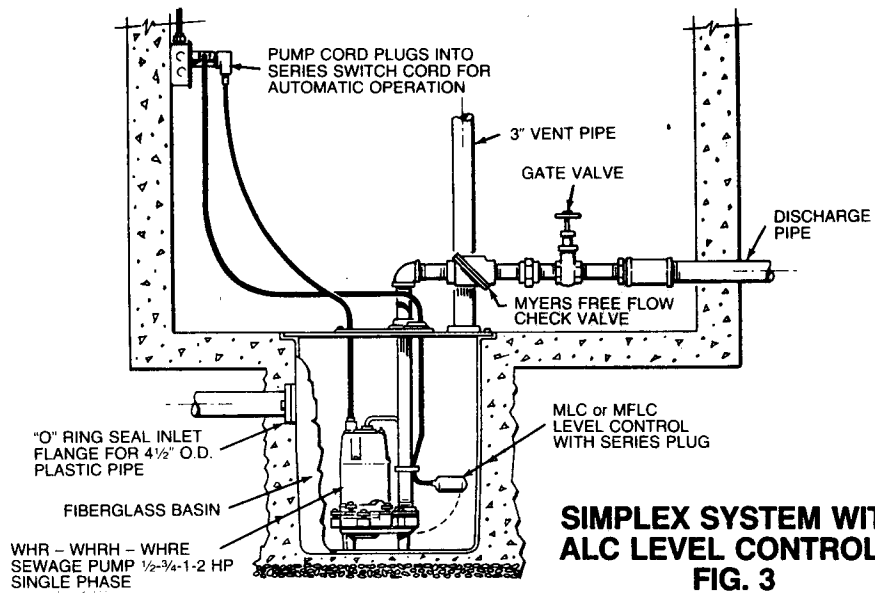

SIMPLEX SYSTEM WITH ALC LEVEL CONTROLS.
FIG. 3

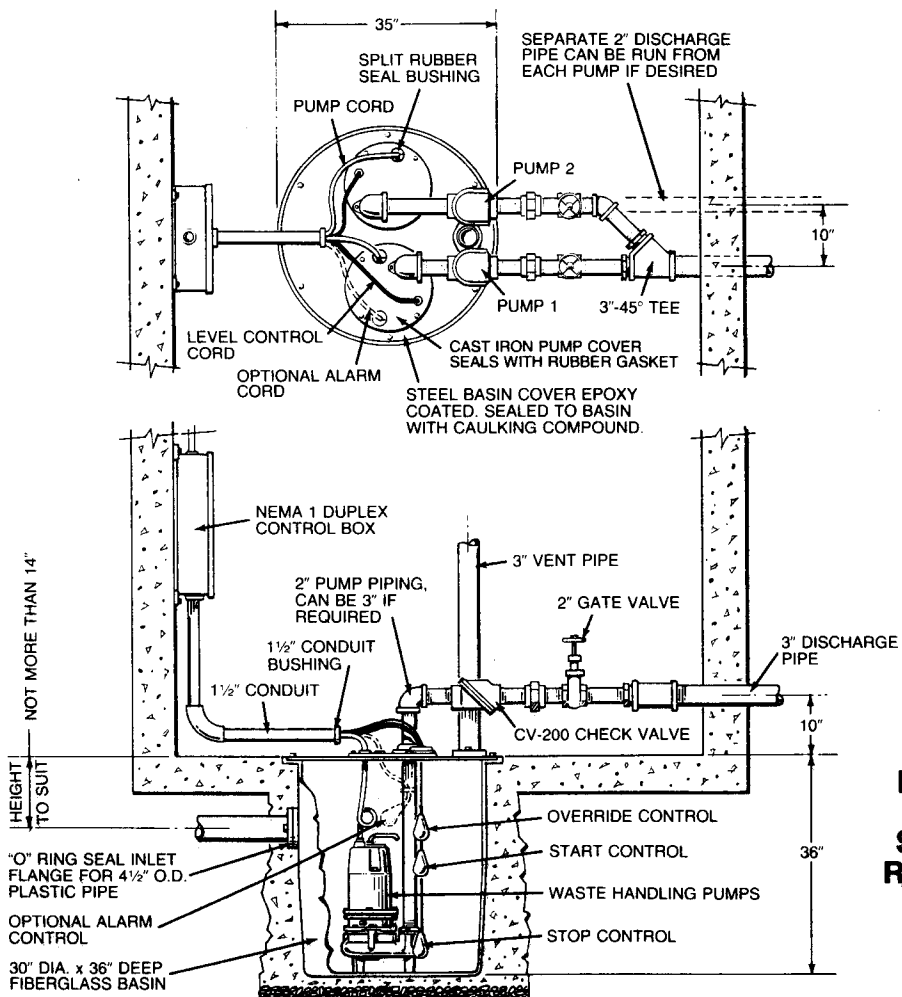

DUPLEX SYSTEM WITH MERCURY FLOAT OR SMNO CONTROLS AND REMOTE CONTROL BOX.
FIG. 4

Basins can be used inside the home where extra capacity sump pumps are required for water softeners and wash water.

If raw sewage must be pumped in the home use outside basins that connect with pressure sewer mains or gravity sewers, or run to septic tanks.

If an inside basin is used it is usually installed at time of pouring the concrete floor.

Pumps can be installed in a compartment of septic tanks for pumping to pressure sewer mains, gravity sewers, leach fields, or evaporation mounds. See Figs. 5, 6 and 7.

PROPER VENTING FOR BASINS INSTALLED INSIDE

All inside sealed basins must have a 2" or 3" vent pipe installed in accordance with local codes. Sumps for handling softener water, wash or drainage water do not have to be sealed or vented.

Outside basins are usually of fiberglass and from 4 to 8 feet deep and have a sealed cover. Pump is usually installed with a lift out rail system so that pump can be removed without disturbing the discharge piping. The check valve comes out with pump for servicing. Complete LIFT OUT SYSTEMS mounted in fiberglass basins are available to meet customers specifications.

WARNING: Sump basin must be vented in accordance with local plumbing codes. These pumps are not designed for and CANNOT be installed in locations classified as hazardous in accordance with the National Electric Code ANSI/NFPA 70.

PIPING

Pumps are fitted with 2" or 3" female threaded pipe flange. Galvanized or PVC plastic pipe can be used. Plastic pipe is preferred for raw sewage or septic tank effluent.

CHECK VALVES AND SHUT-OFF VALVES

All pumps must have check valves and shut-off valves in the discharge line. Check valves must be flapper type with outside spring or ball type. Shut-off valves can be ball or gate type. Plastic construction for both check or shut-off valves is preferred.

STARTING SIMPLEX SYSTEMS

1. For single phase pumps with MLC or MFLC control, plug cords piggy back into receptacle and run water into sump until pump starts. Allow pump to make several on/off cycles. Leave power cord plugged in.

If pump runs but does not pump it may be air locked. Unplug cord and crack union in the discharge line then restart pump, this should vent off any trapped air. Re-tighten union.

AIR LOCKING

A sump pump is said to be air locked if water traps in the pump and it cannot get out, thus preventing pump from operating.

ALL MYERS SUMP PUMPS HAVE A SMALL AIR VENT HOLE IN THE IMPELLER CHAMBER TO LET OUT TRAPPED AIR. IF THIS HOLE BECOMES PLUGGED, PUMP MAY AIR LOCK. THIS USUALLY HAPPENS ON PUMPS THAT ARE USED MAINLY IN THE WET SEASONS. IN SUMMER MONTHS, THE PUMP MAY BE TURNED OFF AS SUMP WATER DRIED UP. WHEN PUMP IS TURNED ON AGAIN AND WATER COMES UP IN SUMP, THE AIR WILL TRAP IN PUMP IF NOT VENTED.

AS A SECONDARY PRECAUTION IN INSTALLATIONS OF THIS TYPE - 1/4" HOLE SHOULD BE DRILLED IN THE DISCHARGE PIPE BELOW THE CHECK VALVE. THE CHECK VALVE SHOULD BE 12 TO 18 INCHES ABOVE PUMP DISCHARGE. DO NOT PUT CHECK VALVE DIRECTLY INTO PUMP DISCHARGE OPENING.

In normal sumps where the pump is operating daily, air locking rarely occurs.

2. With 2 "mercury" controls turn on power at the control box and run water into sump. When level gets above top control pump should start and continue to pump until level drops to lower control stopping pump. Run pump through several cycles. If pump runs but does not pump, check air lock as in 1. Leave power on for automatic operation.
3. Where ALC or AWS-1 controls are used plug in cord or turn on power and run water into sump, when level is about half way up on upper weight pump should start and run until level drops until about half the lower weight is above water, stopping pump. Check 1, if pump does not operate properly.
For all cases if motor does not start when water level is up check for proper plug in or that start switch is on, or if fuse is blown.
ALWAYS HAVE ELECTRICIAN MAKE ELECTRICAL CHECKS.

STARTING PUMP "WHR-P" (AUTOMATIC) USING MECHANICAL SWITCH WITH SERIES PLUG-SIMPLEX SYSTEM

1. These pumps have a mechanical (mercury-free) float switch with a 20 ft. cord and a 115 volt or 230 volt series piggy-back plug on 1/2 H.P. with switch mounted to the pump. On 3/4 H.P. and 1 H.P., it requires 20 ft. cord and 230 volt only.
2. Plug the switch cord plug into a proper voltage, properly grounded outlet.
3. Plug the pump power cord into the back of the switch cord series plug.
4. Tape the cords to the discharge pipe every 12".
5. Run water into sump until pump starts. Be sure discharge line valve is open.
6. Allow pump to operate through several on/off cycles.
7. If pump does not operate properly, see troubleshooting service chart for remedy.

HOW TO SET CONTROLS AND START DUPLEX SYSTEMS

CONTROL BOX MUST BE USED ON ALL DUPLEX SYSTEMS

1. 4 "mercury" controls are used for duplex systems. Set turn-on control 6" to 8" above pumps. Set turn-off control 8" to 10" above bottom of sump. Set override control 6" to 8" above turn-on control. Set high level alarm control about 6" to 8" above override control. Mark all control cords so that they can be connected correctly in the control box. See Fig. 4.
2. Turn Hand-Off-Auto switches to OFF position and close circuit breaker.
3. Turn both H-O-A switches to the AUTO position and run water into sump. When level floats up and activates the turn-on switch one pump should start and run, pump will continue to run until lower control is exposed stopping pump.
4. Run water into sump again and when level floats up turn-on control, opposite pump will start and run until level drops exposing lower control, stopping pump.
5. Run this test several times to be sure pumps are alternating properly.

LEVEL CONTROL SYSTEMS AVAILABLE

1. Simplex single phase packaged automatic system. This system has the MLC or MFLC mercury float switch attached directly to the pump. This system has a fixed pump-off level of 8" to 10" and is usually used for drainage water and is good up to and including 1 H.P.
2. Simplex single phase pumps can use the ALC or AWS-1 controls which are mounted separate from the pump. These controls can be used up to 2 H.P. motors. See Fig. 3.
3. Simplex pumps can use two "mercury" controls mounted separate from the pump. These controls must be used with a control box and magnetic contactor. These controls can be spaced apart for any draw off level required and can be used for 2 H.P. or larger motors.
4. Duplex pump systems must use only the "mercury" controls with electrical control box. These control boxes mounted remote from the sump tank are generally of plastic construction for best corrosion resistance. See Fig. 4.

MOTOR OVERLOAD PROTECTION

All single phase motors have built-in automatic reset overload switches fastened directly to the motor windings.

All 3 phase motors must be installed with magnetic starters having 3 leg overload protection.

HOW TO SET CONTROLS AND START SIMPLEX SYSTEMS

1. Automatic systems – These systems have the MLC, MFLC, or ALC switches mounted on the pump, so pump is installed in the sump and motor cord is plugged into GROUNDED receptacle. For sealed sump cover, power cord is brought through a split rubber plug in the sump cover.
2. Where 2 "mercury" controls are used the turn-on control is set 3" to 6" above top of motor, and the turn-off control is set about 6" to 8" above bottom of sump. If a high level alarm control is used it is set about 6" above upper control. If sump depth will not allow these settings closer spacing can be used.
3. Where ALC or AWS-1 controls are used the DISPLACEMENT WEIGHTS are set so that turn-on weight is 4" to 6" above top of motor and lower weight is set about 6" above sump bottom.
4. Repeat this operation with one pump off which will duplicate a failed pump condition. When the level reaches the override control the pump that is turned on should start and run and pump down sump level.
5. To check high level alarm, again turn both switches to OFF and fill sump until level is above the alarm control. Turn switches to Auto position and ALARM BUZZER should sound and alarm light should come on. When level drops below the alarm control buzzer should stop.
6. If pumps operate as described then set both H-O-A to Auto and pumps are ready to operate automatically.
7. If pumps do not operate properly then check as described for simplex systems. See page 13.

CAUTION — NEVER WORK ON PUMPS OR CONTROL BOXES UNTIL CIRCUIT BREAKERS ARE TURNED OFF.

Always have a qualified ELECTRICIAN make electrical connections and service checks.

SPECIAL INSTRUCTIONS FOR THREE PHASE PUMPS

1. F. E. Myers recommends three phase pumps to be installed by qualified personnel. **CAUTION:** Risk of electric shock. Do not remove cord and strain relief. Do not connect conduit to pump.
2. Three phase pumps are always installed with control boxes having magnetic starters with 3 leg overload protection. **DO NOT TRY TO RUN THREE PHASE PUMPS DIRECTLY ACROSS THE LINE.**
3. To Connect Pump: Run wire from pump to the bottom of control box or appropriate junction box suitable for enclosing splice connections. A hole must be cut into the control box for the wires. With power to control box off, connect green (ground) line to ground lug. Connect black (power) wires to power lead terminals. Make sure that all wires are inside control box and not in a position to be pinched or shorted when the door is closed. See wiring diagrams, page 8.
4. All three phase motors can run either direction. **ROTATION** can be changed by interchanging any two line leads at magnetic starter. **BE SURE CIRCUIT BREAKER IS OFF BEFORE MAKING THIS CHANGE.**

To find if rotation is correct operate pumps and check delivery operation. If flow and head is low (refer to pump curves shown in this manual) the rotation is wrong. With duplex pumps check operation of both pumps.

5. All pump impellers either single or three phase must turn counterclockwise when looking into pump inlet. If uncertain of rotation, **TURN OFF POWER** and lift pump from basin with cord connected and lay pump on side so impeller can be seen. Turn on power and start pump using hand position of H-O-A switch. Turn on and off fast so that coast of impeller can be seen. **NEVER PUT HAND OR FINGERS ON THE IMPELLER.** Interchange any two line leads at the magnetic starter to change rotation.

WIRING DIAGRAMS SINGLE PHASE MOTORS

SINGLE PHASE PUMPS

WARNING – Risk of electric shock. This pump is supplied with a grounding conductor and grounding-type attachment plug. To reduce the risk of electric shock, be certain that it is connected only to a properly grounded, grounding-type receptacle.

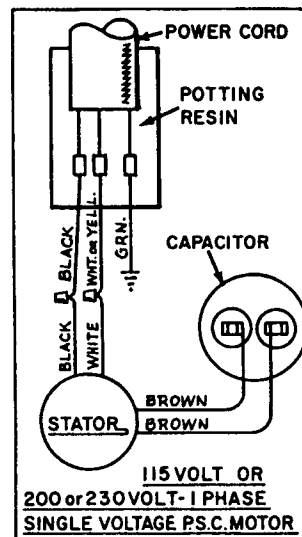

SINGLE SEAL PUMPS AND DOUBLE SEAL PUMPS WITHOUT SEAL LEAK PROBE

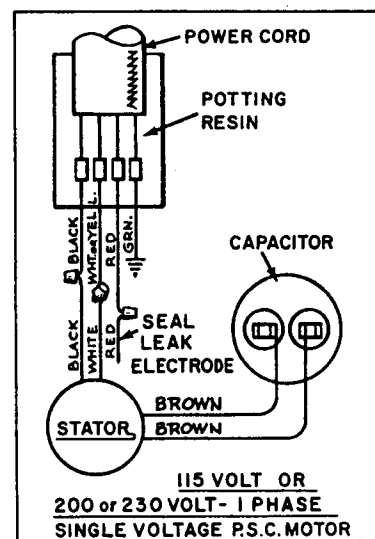

DOUBLE SEAL PUMPS WITH SEAL LEAK PROBE

(RED CONDUCTOR IN POWER CORD IS FOR SEAL LEAK PROBE)

WIRING DIAGRAMS FOR 3 PHASE MOTORS

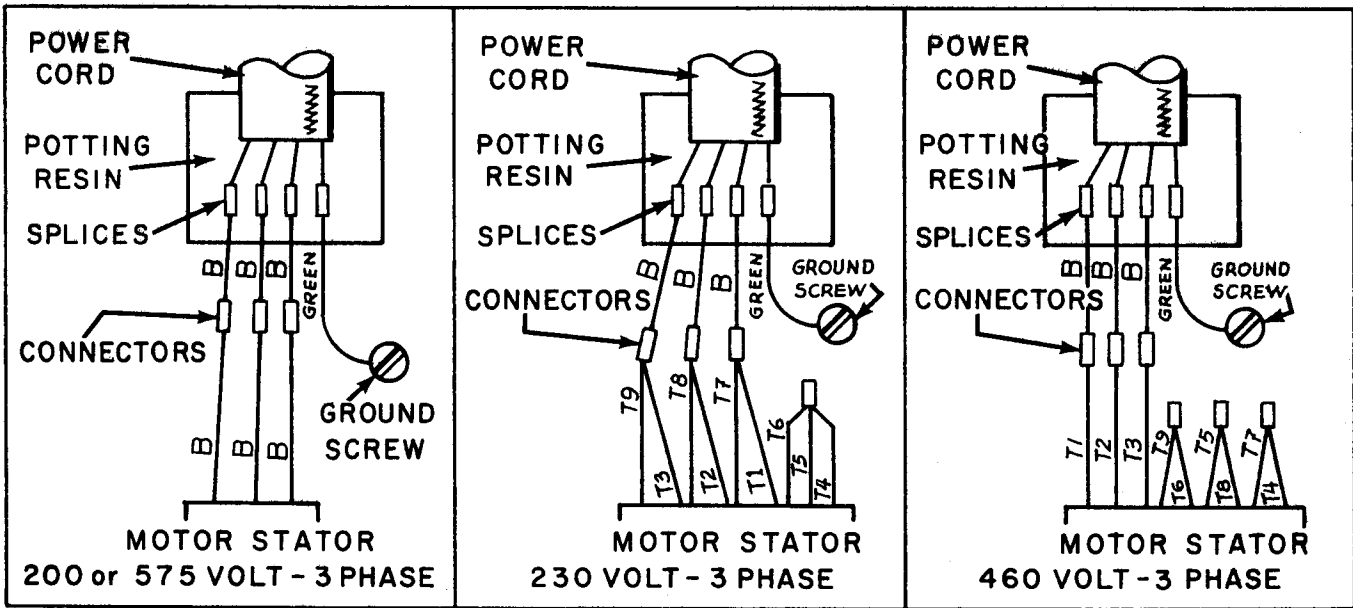

FOR SINGLE SEAL PUMPS AND DOUBLE SEAL PUMPS
WITHOUT SEAL LEAK PROBE

PERFORMANCE CURVES

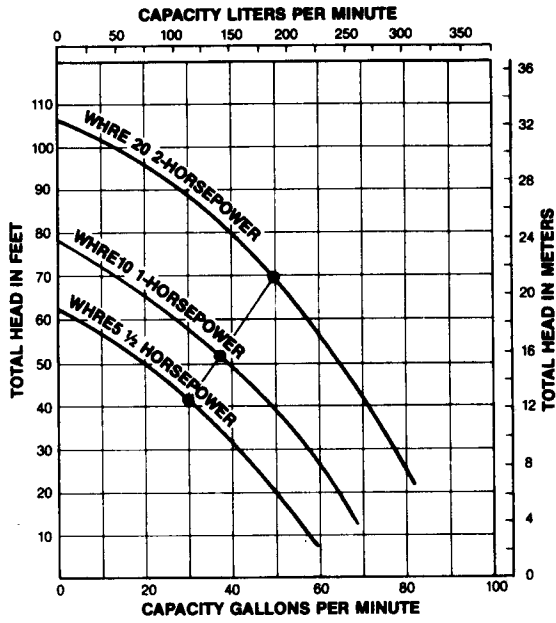

PERFORMANCE CURVE
WHRE SERIES EFFLUENT PUMPS

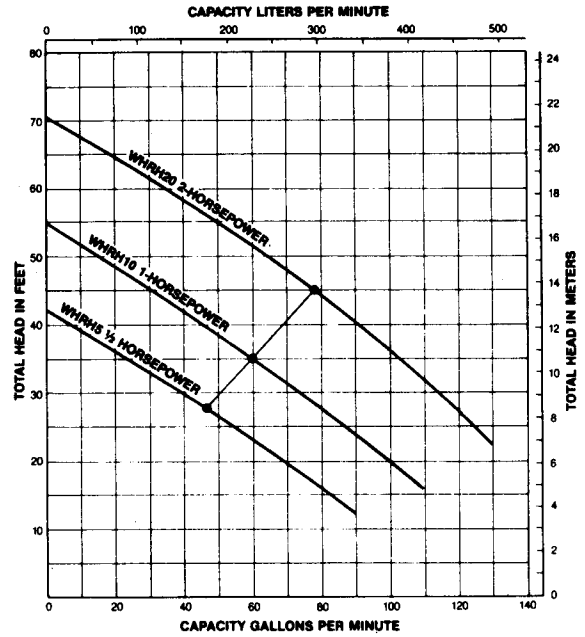

PERFORMANCE CURVE
WRRH SERIES WASTE HANDLING PUMPS

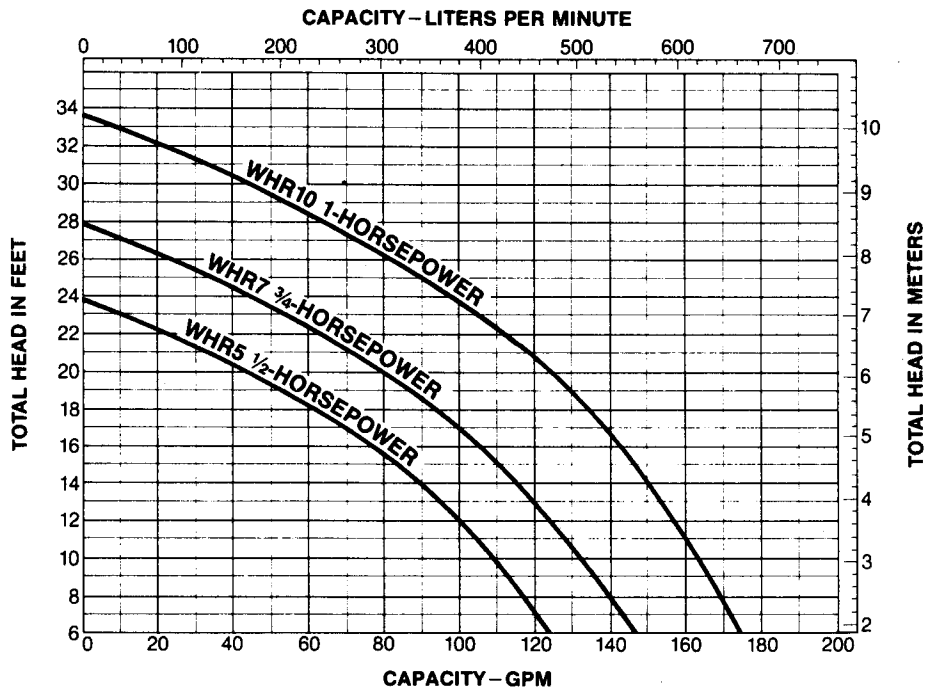

PERFORMANCE CURVE
WHR SERIES WASTE HANDLING PUMPS

FIG. 5 PUMP IN SEPARATE TANK PUMPING TO SEEPAGE MOUND

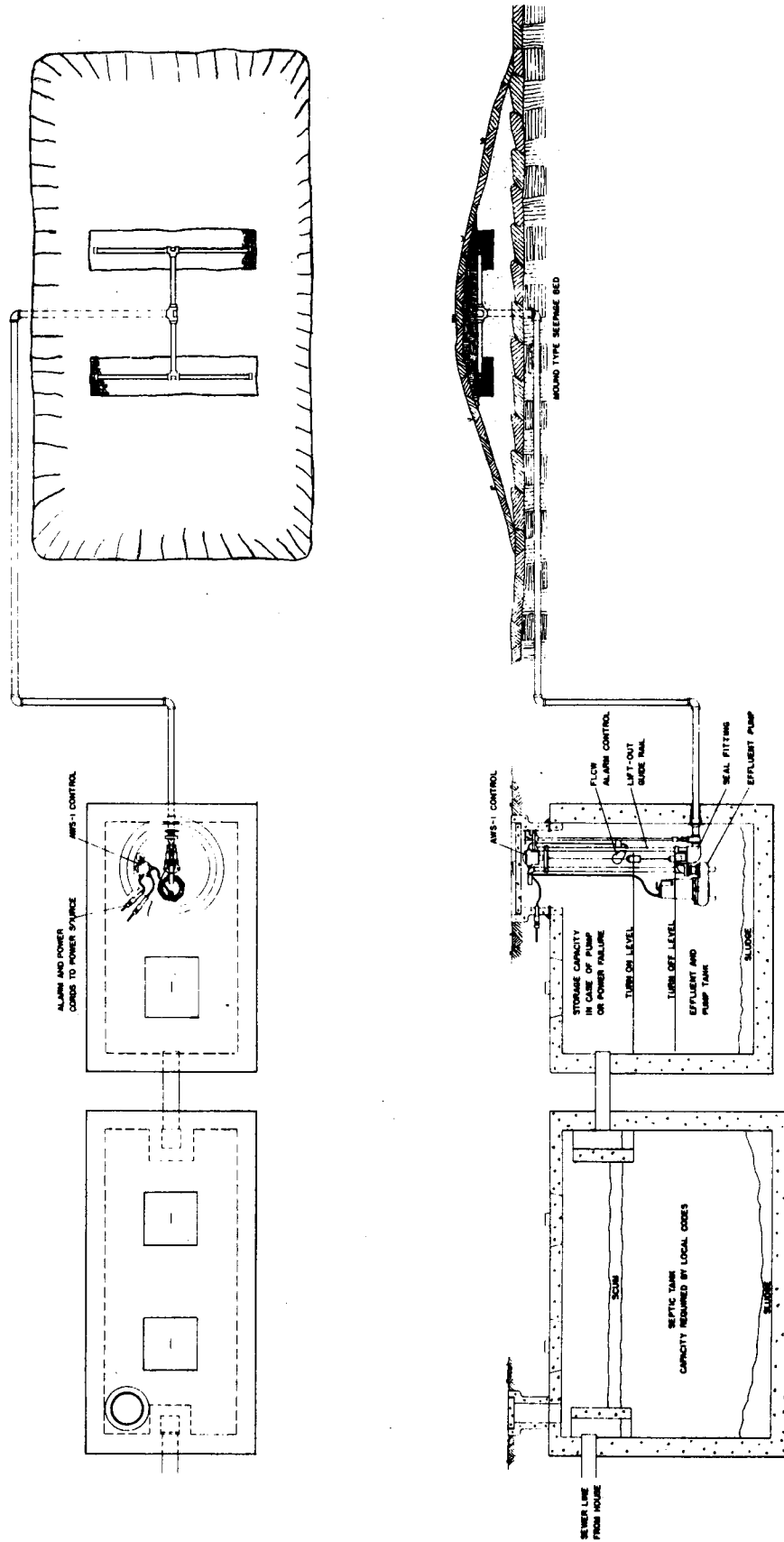

FIG. 5

FIG. 6 PUMP INSTALLED IN FIBERGLASS BASIN AT OUTLET OF SEPTIC TANK USED WHEN PUMPING INTO PRESSURIZED SEWER MAIN OR LEACH FIELD

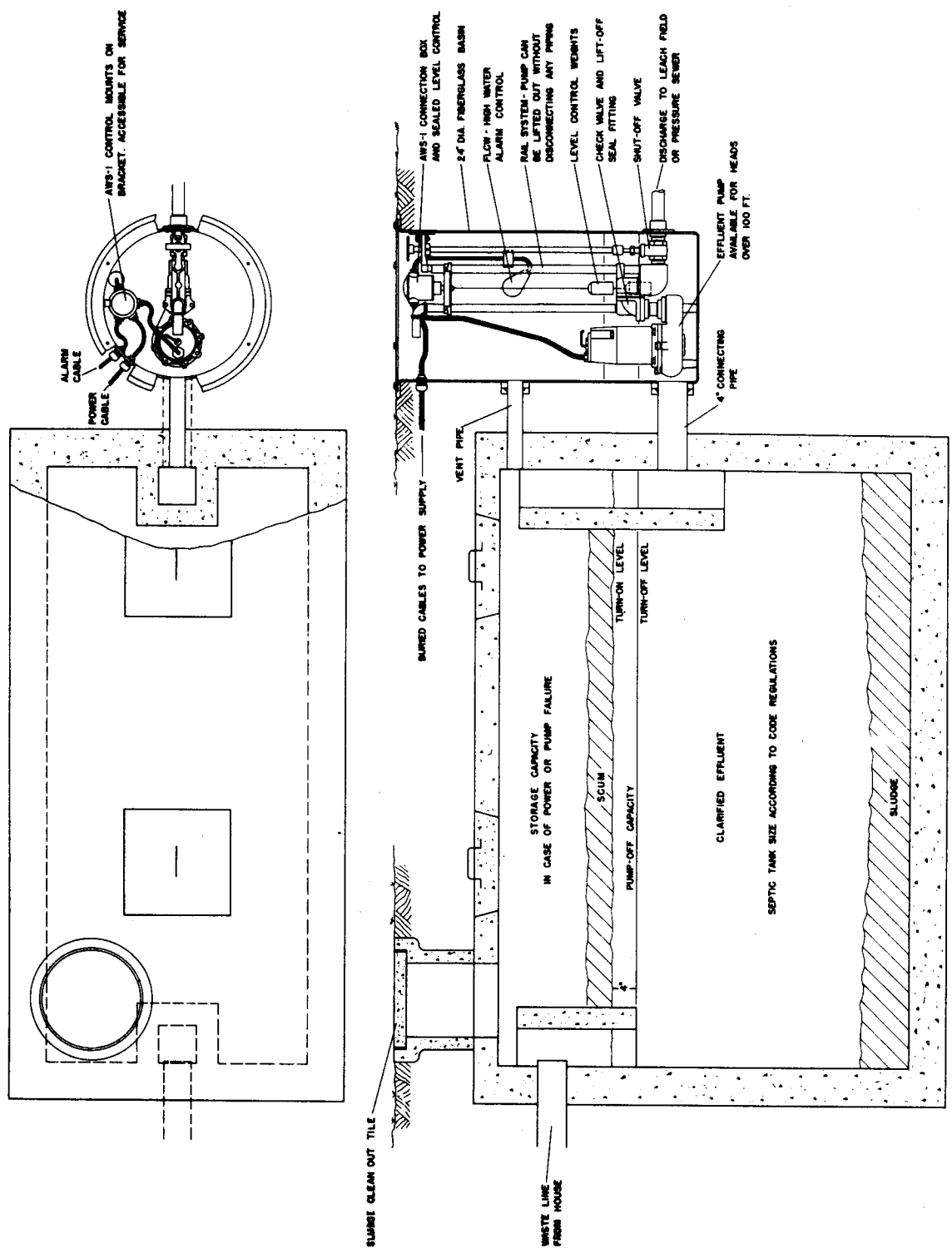
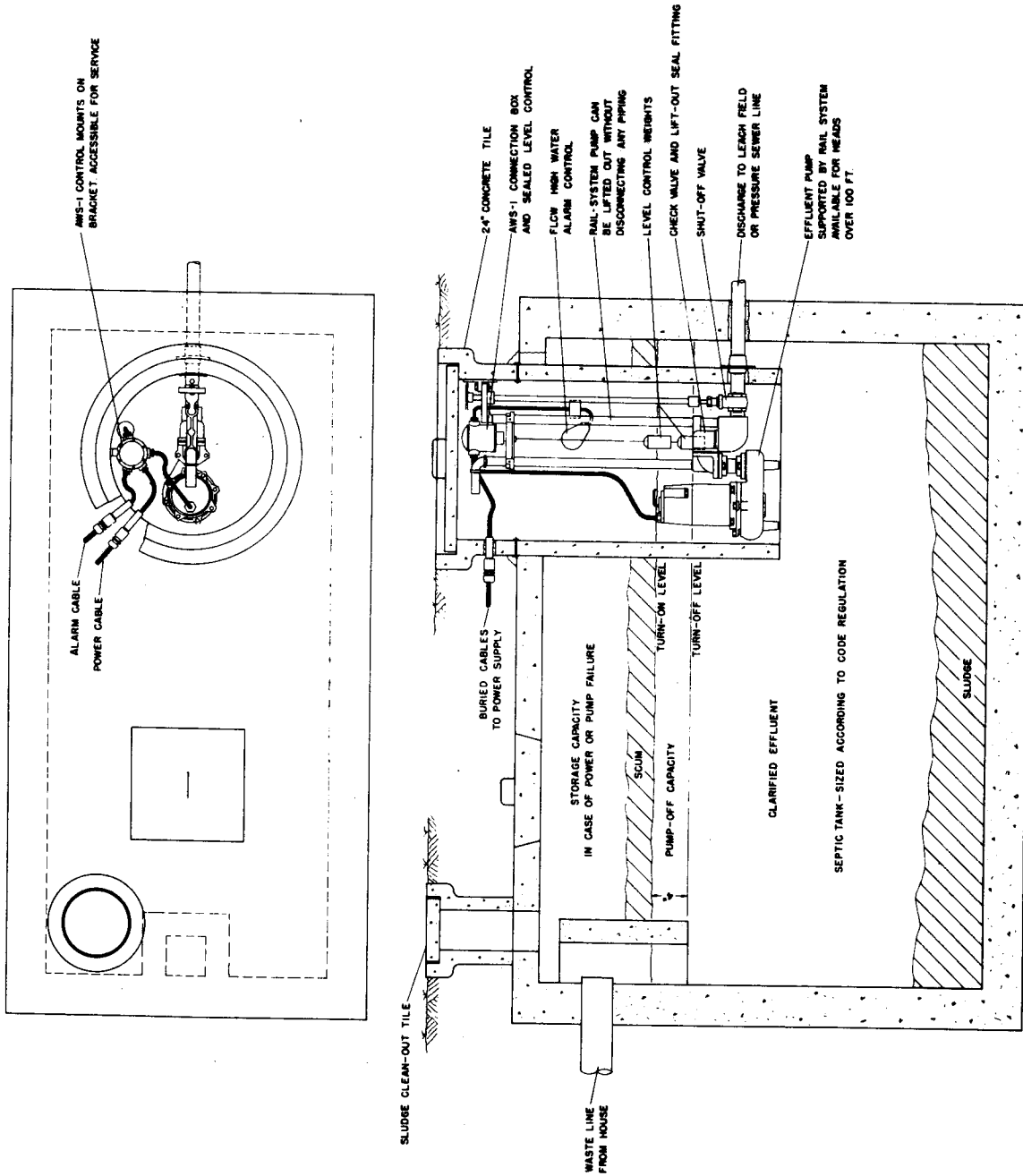

FIG. 6

FIG. 7 PUMP AND CONTROLS INSTALLED DIRECTLY IN SEPTIC TANK USED WHEN PUMPING INTO PRESSURIZED MAIN OR LEACH FIELD



POINTS TO CHECK IF PUMP DOES NOT RUN OR DOES NOT RUN PROPERLY

1. Pump does not run or start when water is up in sump.
 - a. Check for blown fuse or tripped circuit breaker.
 - b. Check for defective level switch.
 - c. Where control panel is used be sure H-O-A switch is in the Auto position. Turn switch to the HAND position and if pump runs then trouble is in the automatic electrical system. Have ELECTRICIAN make electrical checks.
 - d. Check for burned out motor. Occasionally lightning can damage a motor even with lightning protection.
 - e. Where plug-in cords are used be sure contact blades are clean. **DO NOT USE PLUG-IN CORDS INSIDE A SUMP OR WET WELL.**
2. Pump runs but does not deliver flow.
 - a. Check for air lock. Start and stop pump several times if this does not help it may be necessary to loosen a union in the discharge line to relieve air lock.
 - b. Check valve may be installed backward. Check flow arrow on valve body. Check shut-off valve it may be closed.
 - c. Check vertical elevation, it may be higher than pump can develop. (See pump curve.)
 - d. Pump inlet may be plugged with a rag or trash. Remove pump to check.
 - e. If pump is three phase be sure pump rotation is correct. (See instructions for checking rotation.)
 - f. Level control ball or weight may be stuck on side of basin. Trash may be stuck on ball preventing it from floating up.

CAUTION: ALWAYS UN-PLUG CORD OR TURN OFF CIRCUIT BREAKER BEFORE DOING ANY WORK ON THE PUMP. If control panel is remote from pump, disconnect lead wires to motor so that someone cannot turn the circuit breaker back on. If motor is three phase mark the leads so they can be replaced in same order.

DISMANTLING PUMP FOR REPLACEMENT OF PARTS

Clean pump thoroughly. Knock off all scale and deposits. Use sandblast if possible. Submerge complete unit in Clorox solution for one hour before taking apart.

TO REPLACE CAPACITORS ONLY

The motors on all WHR, WHRH and WHRE series single phase pumps are of the permanent split capacitor type, so have no relays or starting switch, and have only a starting capacitor that is in the circuit for both starting and running conditions.

1. Remove oil fill plug in top of motor and pour out oil. Fig. 8
2. Remove bolts from capacitor housing and bump housing with plastic hammer to loosen. Fig. 9
3. Lift housing and disconnect motor leads and capacitor wires. Fig. 10
4. Remove capacitor clamp and slide out capacitor. Replace with new capacitor and re-connect. Fig. 11.
Wiring connections are given in these instructions.
5. Replace capacitor housing, be sure rubber seal ring is in place. Fig. 12.
6. Refill motor with Myers submersible motor oil. **DON'T OVER FILL WITH OIL. OIL LEVEL SHOULD BE ONE INCH FROM TOP OF CASTING.** Fig. 13.
7. Be sure pump turns free before plugging into power. Turn pump on side and turn impeller, using screwdriver in slotted shaft.

Plug pump into receptacle to test operation. Pump must run quiet and free of vibration.



FIG. 8

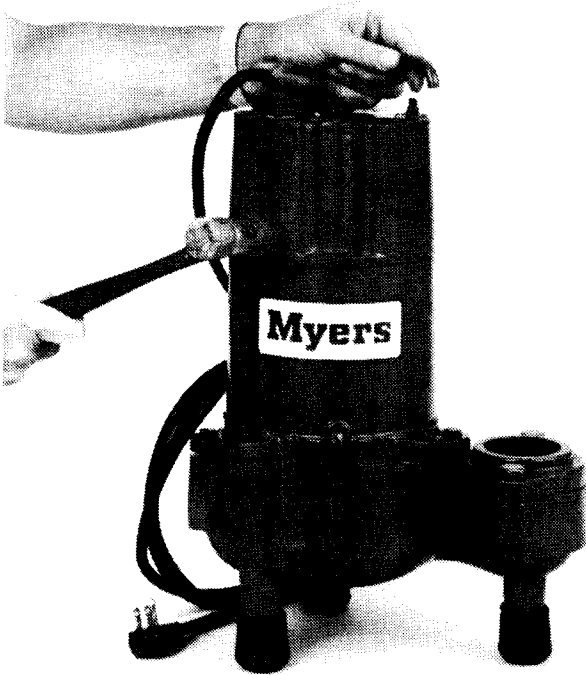

FIG. 9

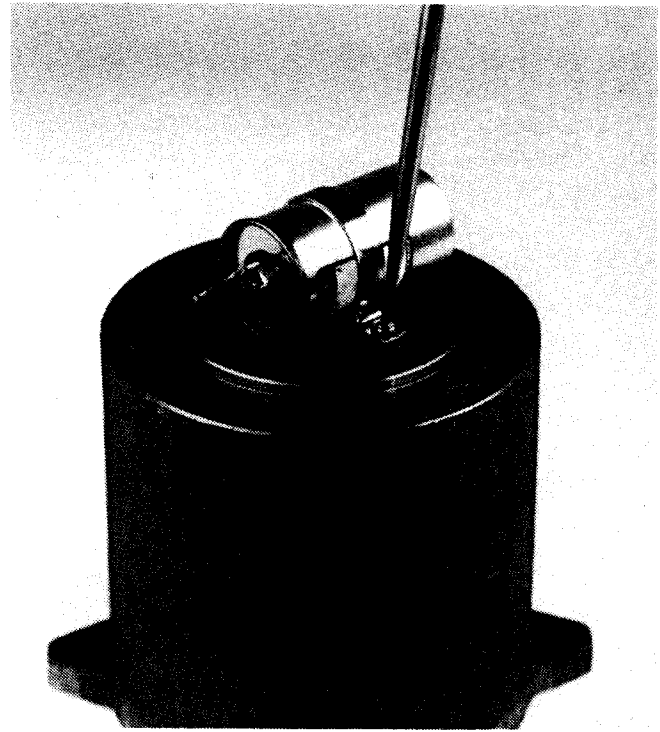

FIG. 11

TO REPLACE POWER CORD ONLY

1. Remove capacitor housing as described above. Disconnect cord leads from motor and remove ground screw.
2. Unscrew cord bushing and remove from housing. Fig. 14.

3. Replace with new fitting and cord, be sure "O" ring seal is in place. Fig. 14.
4. Replace ground screw and re-connect motor wires. Wiring diagram is given in these instructions.



FIG. 10

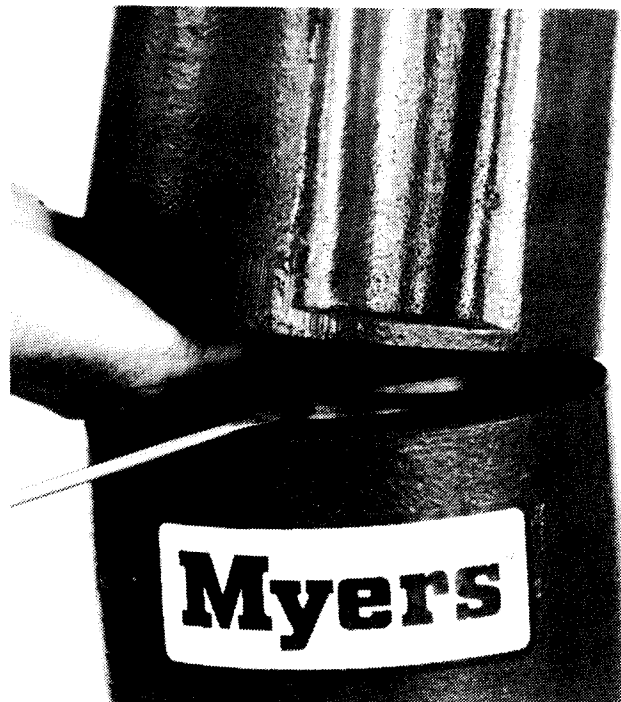

FIG. 12

5. Replace capacitor housing and refill motor with Myers submersible oil. See Fig. 13 for oil level. One inch from top of casting.

COMPLETELY DISMANTLE PUMP TO REPLACE MOTOR STATOR AND SEAL

1. Pour oil from motor and remove capacitor housing as described above.
2. Remove bolts from motor housing only. Do not remove bolts that hold motor plate to volute case. Fig. 15.
3. Lift off motor housing, pry between ears to loosen. Fig. 16.
4. Remove case holding bolts and lift out rotating unit. Pry between ears to loosen. Fig. 17.
5. Hold rotor and unscrew impeller locking nut. Turn counter-clockwise as thread is right hand. Fig. 18.
6. Unscrew impeller, turn counter-clockwise to loosen. Fig. 19.
7. Pry off seal with screwdrivers. It is not important if seal is damaged, as it must be replaced. Replace both parts of seal, never one or the other. Fig. 20.
8. Bump shaft on end with plastic hammer to push ball bearing from lower motor plate. Fig. 21.
9. Clean seal cavity thoroughly before replacing ceramic seal. Use grease on rubber cup of seat and push into housing, use plastic rod to push



FIG. 14

into place. Clean seal face to remove any speck of dirt, and use light oil on face before installing bellows part of seal. Fig. 22.

10. If necessary to replace ball bearing, press off in arbor press. Use strips of metal between bearing and rotor to press off. Fig. 23. Always press on inner race of bearing when replacing.



FIG. 13

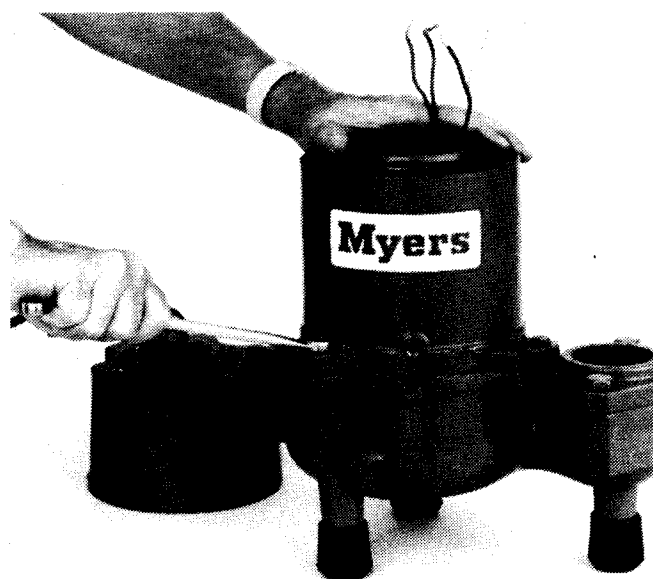

FIG. 15

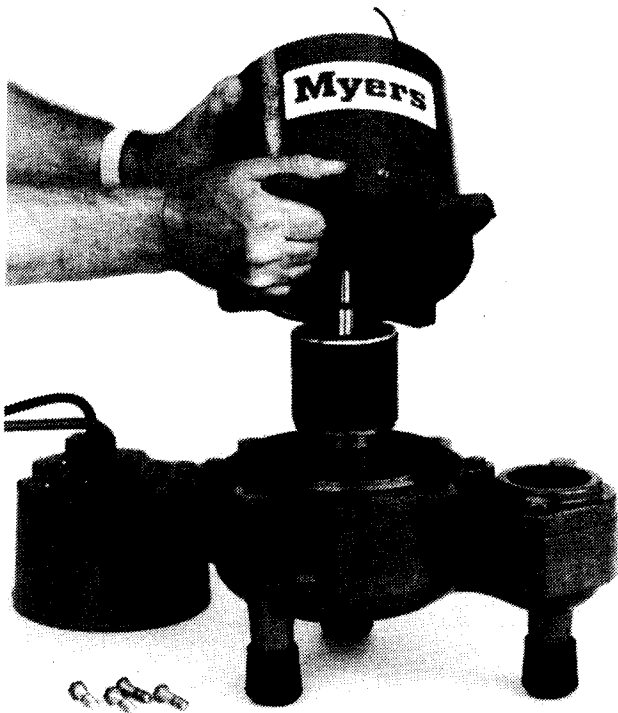

FIG. 16

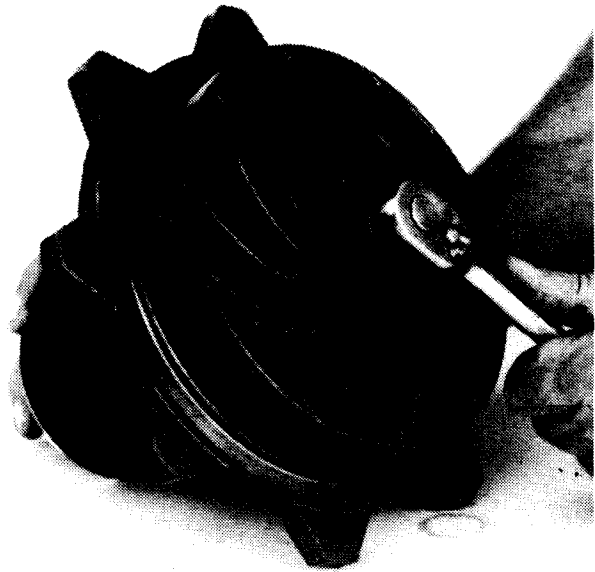

FIG. 18

11. If necessary to replace motor stator, use new housing with stator pressed in.

Both housing and stator must be replaced as a unit, as stator is pressed in at factory and is not to be replaced in the field. Fig. 24.

12. In reassembly, be sure rubber seal ring and thrust washer are in place as shown. Fig. 25.

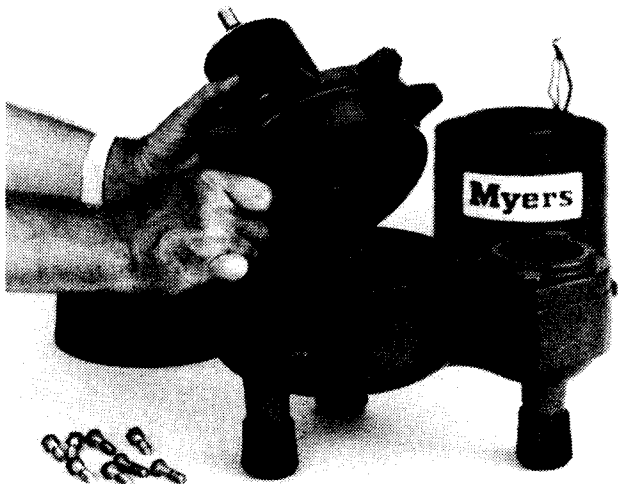

FIG. 17



FIG. 19

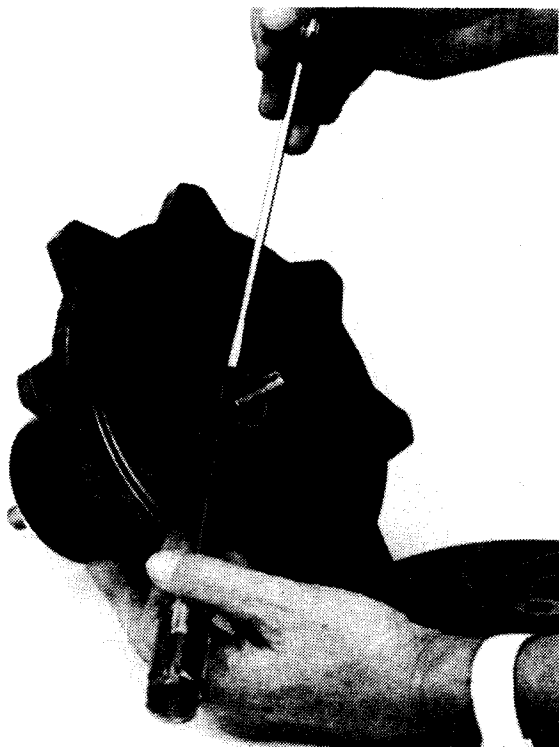

FIG. 20

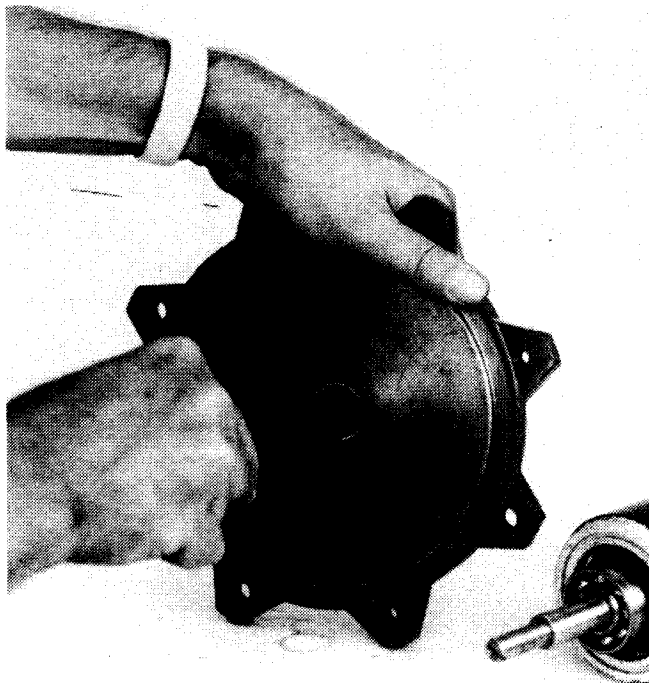

FIG. 22



FIG. 21

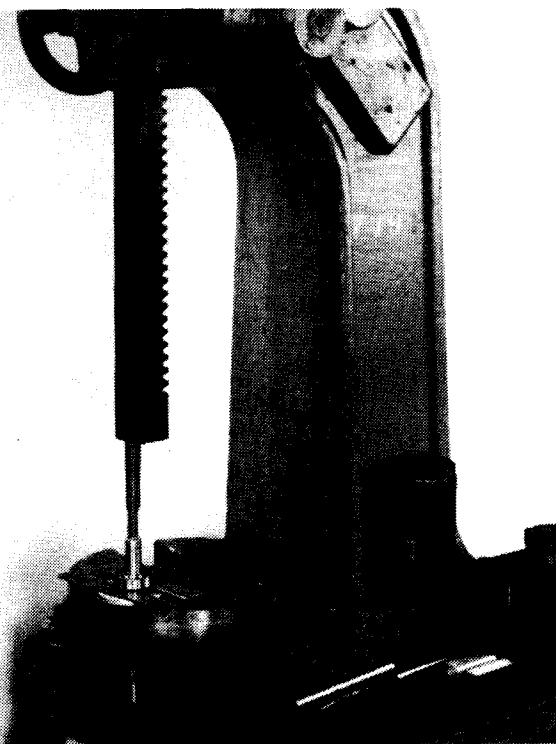

FIG. 23

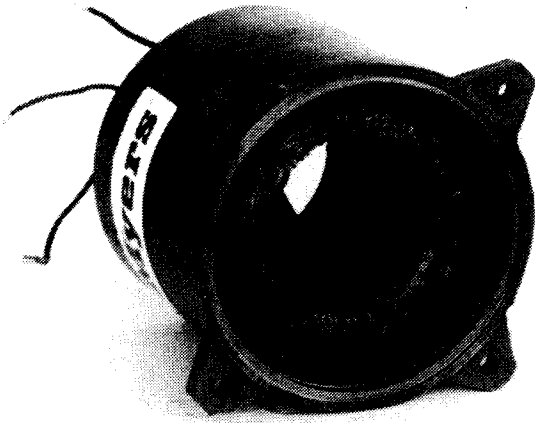

FIG. 24

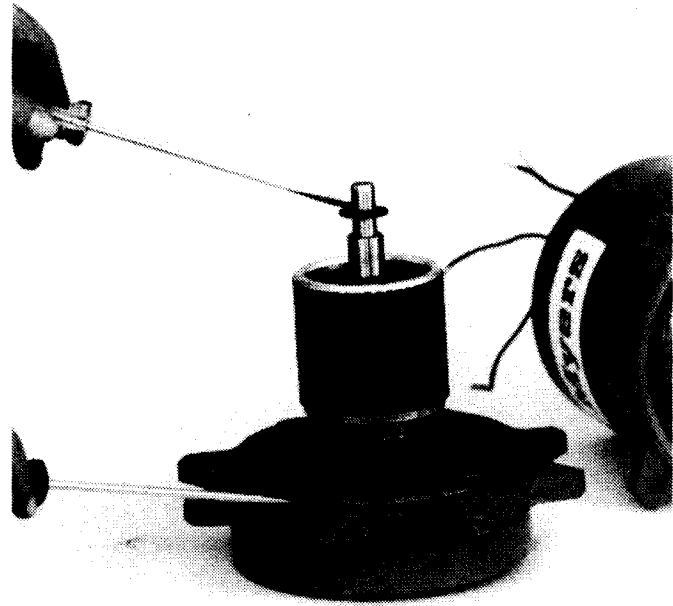
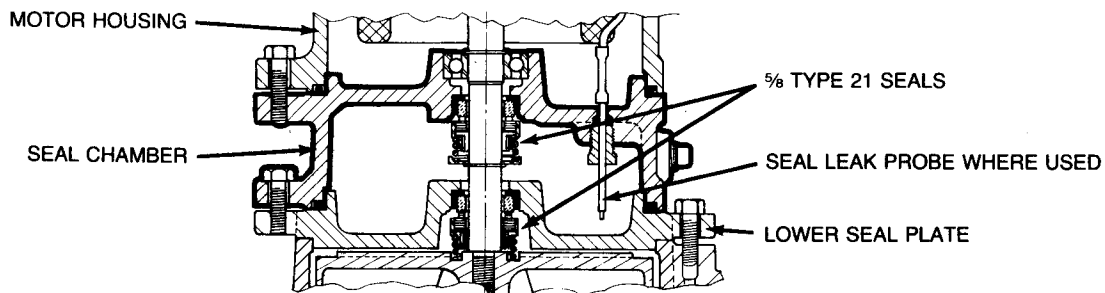

FIG. 25

SPECIAL INSTRUCTIONS FOR REPLACING SEALS IN DOUBLE SEAL PUMPS

1. Remove plugs in motor housing and in seal housing and drain oil.
2. Remove bolts in lower plate only.
3. Lift off pump case.
4. Hold impeller and unscrew holding nut. Hold shaft with screwdriver and unscrew impeller, turn counterclockwise.
5. Pry off seal bellows and ceramic seat. Break seats if necessary to get out as they must be replaced with new parts.
6. NEVER USE OLD SEAL PARTS. USE ONLY COMPLETE NEW SEALS.
7. Remove snap ring with snap ring pliers.
8. Pry off upper seal bellows and ceramic seat.
9. If no water has entered motor housing (check winding with ohmmeter or megger) wipe seal chamber thoroughly and replace seals.
10. Replace oil in motor housing and seal chamber. Use only MYERS submersible oil.
11. If water has been in motor then remove seal chamber and lift out rotor unit and remove motor stator. See single seal instructions for replacing ball bearing and motor stator.



PUMP DIMENSIONS

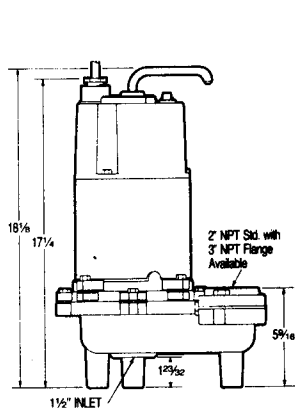
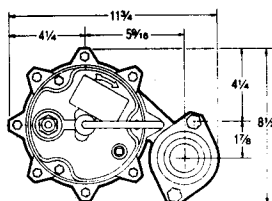
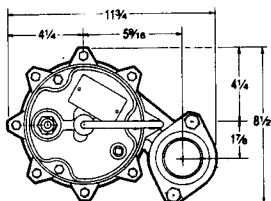

WRRH

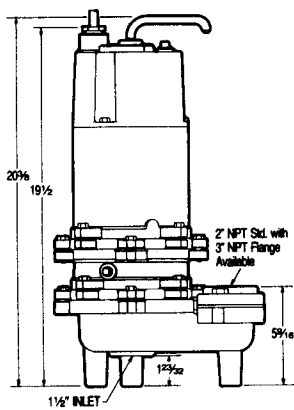

WRRH-DS

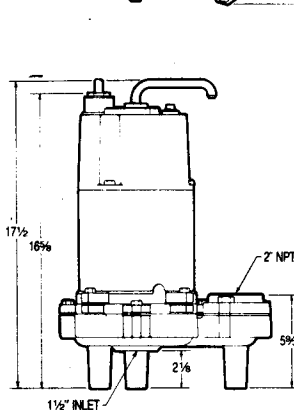

WHRE

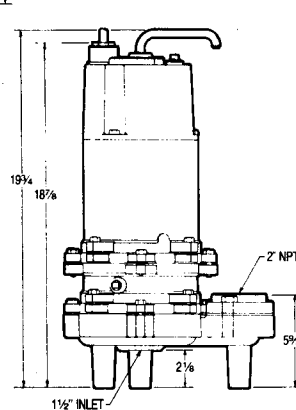

WHRE-DS

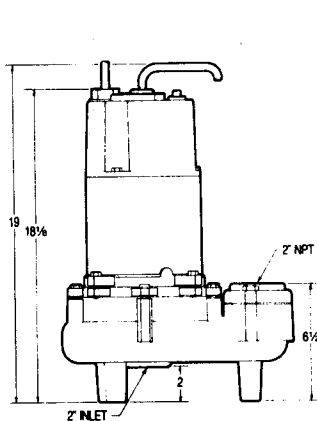
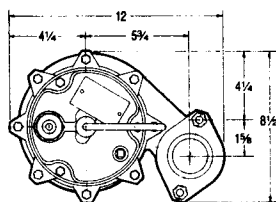

WHR

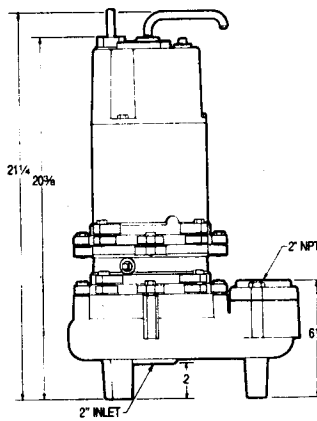

WHR-DS

MYERS LIMITED WARRANTY SUMP & RESIDENTIAL SEWAGE

During the time periods and subject to the conditions hereinafter set forth, **F. E. Myers** will repair or replace to the original user or consumer any portion of your new **MYERS** product which proves defective due to defective materials or workmanship of **MYERS**. Contact your nearest Authorized **MYERS** Dealer for warranty service. At all times **MYERS** shall have and possess the sole right and option to determine whether to repair or replace defective equipment, parts, or components. Damage due to lightning or conditions beyond the control of **MYERS** is NOT COVERED BY THIS WARRANTY.

WARRANTY PERIOD

Pumps: 12 months from date of installation or 18 months from date of manufacture, whichever occurs first.

Labor, etc. Costs: **MYERS** shall IN NO EVENT be responsible or liable for the cost of field labor or other charges incurred by any customer in removing and/or reaffixing any **MYERS** product, part or component thereof.

THIS WARRANTY WILL NOT APPLY: (a) to defects or malfunctions resulting from failure to properly install, operate or maintain the unit in accordance with printed instructions provided; (b) to failures resulting from abuse, accident or negligence; (c) to normal maintenance services and the parts used in connection with such service; (d) to units which are not installed in accordance with applicable local codes, ordinances and good trade practices; or (e) unit is used for purposes other than for what it was designed and manufactured, and (f) if three phase submersible motors are installed on a single phase power supply using a phase converter or if three phase power is supplied by only two transformers, making an open Delta system.

RETURN OR REPLACED COMPONENTS: any item to be replaced under this Warranty must be returned to **MYERS** in Ashland, Ohio, or such other place as **MYERS** may designate, freight prepaid.

PRODUCT IMPROVEMENTS: **MYERS** reserves the right to change or improve its products or any portions thereof without being obligated to provide such a change or improvement for units sold and/or shipped prior to such a change or improvement.

WARRANTY EXCLUSIONS: As to any specific **MYERS** product, after the expiration of the time period of the warranty applicable thereto as set forth under the heading "Warranty Periods" above, THERE WILL BE NO WARRANTIES INCLUDING ANY IMPLIED WARRANTIES OF MERCHANTABILITY OR FITNESS FOR ANY PARTICULAR PURPOSE

Some states do not allow limitations on how long an implied warranty lasts, so the above limitation may not apply to you. No warranties or representations at any time made by any representative of **MYERS** shall vary or expand the provisions hereof.

LIABILITY LIMITATION: IN NO EVENT SHALL **MYERS** BE LIABLE OR RESPONSIBLE FOR CONSEQUENTIAL, INCIDENTAL OR SPECIAL DAMAGES RESULTING FROM OR RELATED IN ANY MANNER TO ANY **MYERS** PRODUCT OR PARTS THEREOF.

Some states do not allow the exclusion or limitation of incidental or consequential damages, so the above limitation or exclusion may not apply to you.

This Warranty gives you specific legal rights and you may also have other rights which vary from state to state. In the absence of suitable proof of this installation date, the effective date of this warranty will be based upon the date of manufacture plus one year.

Direct All Notices, etc. To: Service Department, **F. E. MYERS**, 1101 Myers Parkway, Ashland, Ohio 44805-1969.

DETERMINATION OF UNIT DATE OF MANUFACTURE: Submersible Sump pump (8-84) month and year stamped on pump nameplate; column sump pump subtract 18 months from month and year on red warranty tag.

Myers[®]

F.E. Myers
1101 Myers Parkway
Ashland, Ohio 44805-1969

419/289-1144
FAX: 419/289-6658, TLX: 948-7443