

Series 550 Pump

Model: 55XX-XX01-B606

Flow Range: Open Flow = 3.90-6.00 GPM

At 70 PSI = 1.50-3.20 GPM

COMPLETING THE PART NUMBER:

55XX-XX01-B606

DESIRED SHUT-OFF PRESSURE

0 = NONE B = 40PSI D = 50PSI F = 70PSI
A = 30PSI C = 45PSI E = 60PSI

0 = NO CONTROL (MUST NOT EXCEED 70 PSI)
1 = PRESSURE SWITCH CONTROL (STANDARD)

SELECT MODEL FROM PERFORMANCE DATA CHART

0 = QUICK DISCONNECT PORT
1 = 1/2" NPT (FEMALE) PORT

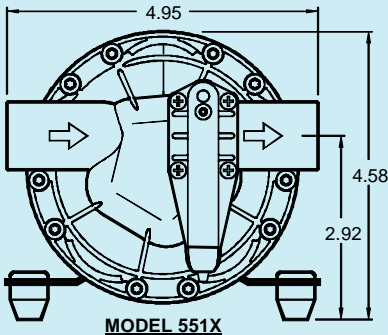

MODEL 551X

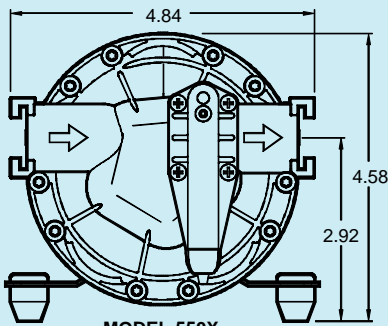

MODEL 550X

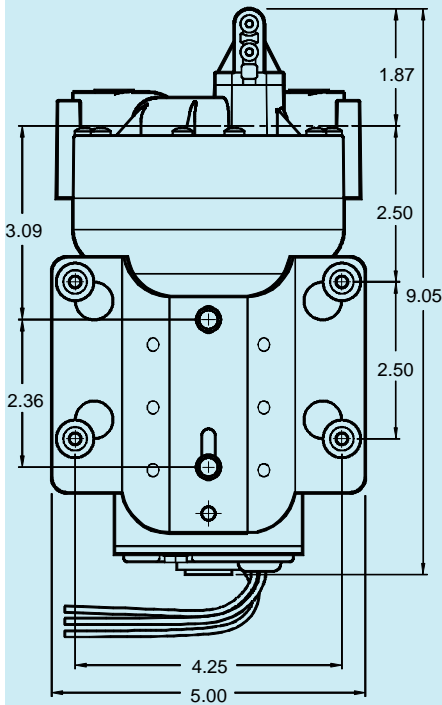

WEIGHT: 6 lbs.

SPECIFICATIONS:

■ MOTOR:

TYPE:

115 VAC, 60 HZ, Permanent Magnet,
Totally Enclosed, Non-Ventilated

LEADS:

14 AWG, 12" LONG

TEMP. LIMITS:

For User Safety, Optimal Performance, and
Maximum Motor Life, This Motor is Equipped
with a Thermal Protector that Limits the Motor
Shell Temperature to 145°F (63°C), as Shown on
the Heat Rise Graph.

DUTY CYCLE:

See Heat Rise Graph

■ PUMP DESIGN:

5 Chamber Diaphragm Pump, Self Priming,
Capable of Being Run Dry

■ TYPICAL APPLICATION:

Industrial Grade Water Transfer

■ MATERIALS:

HOUSINGS:

Nylon

VALVES:

EPDM

DIAPHRAGM:

Santoprene

FASTENERS:

Stainless Steel

■ LIQUID TEMPERATURE:

170°F (77°C) Max.

■ PUMP CERTIFICATIONS:

NSF Standard 58

■ PRIMING CAPABILITIES:

	55X0	55X1	55X2	55X3
PRIME (FEET)	7	7.5	10	11

■ FITTINGS:

TYPE	SHAPE	HOSE BARB SIZE		
		1/2"	5/8"	3/4"
QUICK DISCONNECT	STRAIGHT	QBS-554	QBS-555	QBS-556
(MODEL 550X)	ELBOW	QBE-554	QBE-555	QBE-556
NPT (FEMALE)	STRAIGHT	MPS-554	MPS-555	MPS-556
(MODEL 551X)	ELBOW	MPE-554	MPE-555	MPE-556



Aquatec Water Systems, Inc.
17422 Pullman
Irvine, CA 92614
Sales: 949-225-2200
Fax: 949-225-2222

DOCUMENT:
ISSUED:
REVISED:

DS55XX-XX01-B606
10/27/99
10/27/99

Series 550 Pump

Model: 55XX-XX01-B606

PERFORMANCE DATA								
DISCHARGE	PUMPHEAD							
PRESSURE	55X0		55X1		55X2		55X3	
(PSI)	FLOW (GPM)	CURRENT (AMPS)	FLOW (GPM)	CURRENT (AMPS)	FLOW (GPM)	CURRENT (AMPS)	FLOW (GPM)	CURRENT (AMPS)
70	1.50	1.21	2.20	1.97	2.64	2.20	3.20	2.60
60	1.75	1.14	2.45	1.65	2.90	2.02	3.50	2.34
50	2.00	1.12	2.66	1.50	3.18	1.87	3.86	2.14
40	2.26	1.05	2.90	1.36	3.50	1.70	4.25	2.00
30	2.58	0.96	3.25	1.23	4.00	1.50	4.73	1.78
20	3.03	0.85	3.75	1.08	4.50	1.33	5.30	1.56
10	3.45	0.73	4.18	0.92	5.07	1.10	5.75	1.34
OPEN	3.90	0.64	4.63	0.84	5.50	1.08	6.00	1.26

PERFORMANCE MEASURED WITH FLOODED INLET (0 PSI), 70°F (21°C) AMBIENT AND WATER TEMPERATURE, AND VOLTAGE CONTROLLED AT 115 VAC. POSITIVE INLET PRESSURE WILL INCREASE THE DISCHARGE PRESSURE BY A SIMILAR AMOUNT, FOR A GIVEN FLOW. MAXIMUM INLET PRESSURE IS 60 PSI.

SHADED AREA DENOTES CONTINUOUS OPERATION CAPABILITY AT DESIGNATED PRESSURE AND CURRENT.

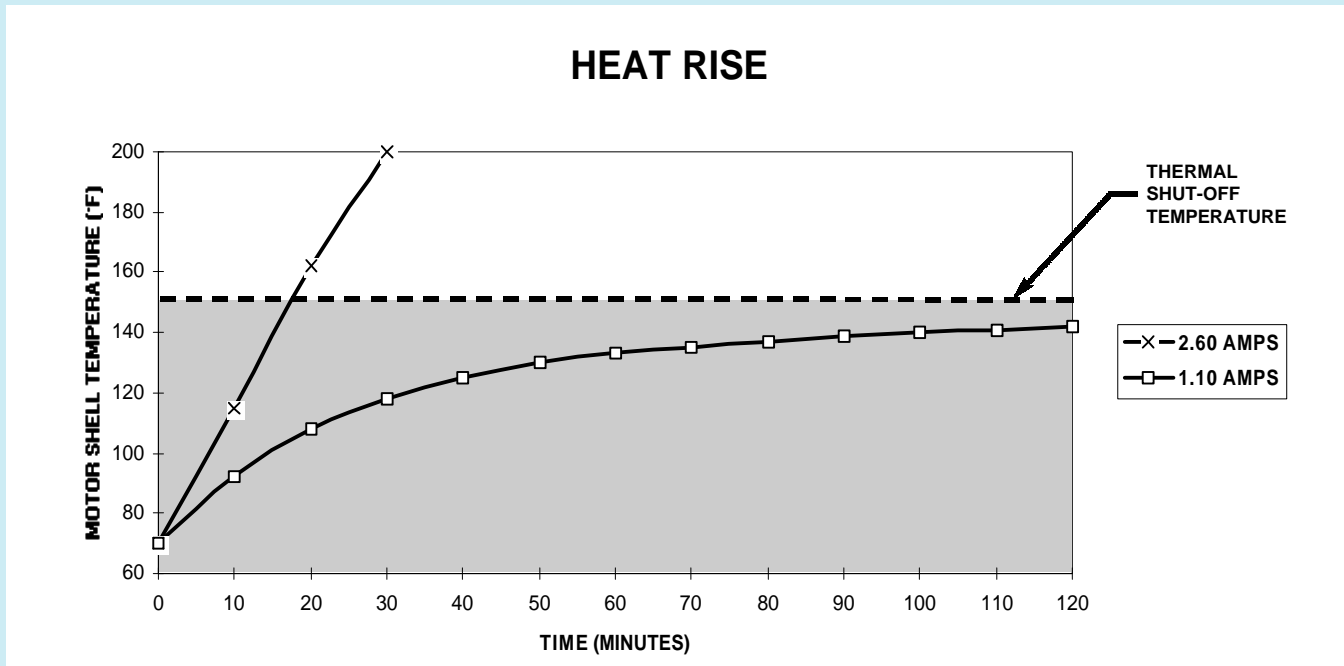

The shaded area in both the Performance Data and Heat Rise charts, contains pumps with current levels that are capable of running without periodic cool down. Pumps in this category will generally transfer more water over sustained periods than those in the unshaded areas, which are required to shut down while the motor cools. Some applications require maximum flows at high pressures for relatively short periods, however, so an explanation of thermal protection follows:

1. The Heat Rise graph plots the highest current that can run without ever leaving the Shaded Area, in this case, 1.10 amps. All pumps with lower operating currents may also run continuously, unless the surrounding air temperature exceeds 70°F (21°C).
2. The other curve shown is the highest flow and pressure model offered, the 55X3. At 70 PSI, this pump will flow 3.2 GPM, drawing 2.60 amps.
3. The motor driving all of these pump models has a built in thermal protector that will open, shutting off the pump, when the surface temperature of the motor heats to approximately 145°F. After the initial room temperature heat rise as shown, the model 55X3 reaches the shut off temperature after about 5 minutes of run time, pumping about 16 gallons at 70 PSI.
4. Motors of this size and construction require 20 to 40 minutes of cooling time before the thermal protector closes and re-energizes the pump. Lower current levels heat more slowly, allowing longer run times, but the cool down time still averages about 30 minutes, at 70°F ambient temperature.
5. Your application may call for short bursts of water, consuming far less than the 5 minutes of sustained operation. Start up current exceeds normal running current, however, so cycling should be limited to 6 times per minute.

ALL PERFORMANCE AND HEAT RISE FIGURES ARE APPROXIMATE. ACTUAL VALUES WILL VARY WITH AMBIENT CONDITIONS.