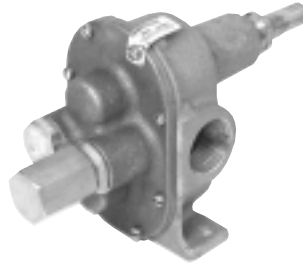

# Installation, Operation, Repair, and Parts Manual

Form 12235  
02/00

---

[PumpBiz.com](http://PumpBiz.com)[1-800-PumpBiz](tel:1-800-PumpBiz)

## INTRODUCTION

Shertech gear pumps are simple and rugged in construction. A minimum number of moving parts assures longer service life and lower maintenance cost. Their design criteria is for high flow at moderate pressures. Pump compactness is another feature when space is at a premium.

## INSTALLATION

Pump should be secured to as rigid a base as possible. Excessive vibrations tend to distort drive alignment of pump, which is one of the major causes of early pump failure.

## DRIVES

When coupling pump directly to drive unit, such as an electric motor, extreme care must be exercised in proper alignment, since improper alignment can produce excessive radial thrust on the drive rotor leading to premature wear and pump failure. Installing any good flexible coupling will go far in eliminating this problem. In the case of pulley drive, even more caution must be taken since, besides misalignment between pulleys, there also exists the tendency to over tighten the belt. This develops excessive side loads and wear on bearing surfaces which shortens pump life. It is recommended when using this type of drive a ball bearing pillow block be installed which will absorb this side load.

## SPEEDS AND LOADS

Pump should not be run in excess of recommended speeds and loads. Doing so will shorten pump life.

## SUCTION

For best performance the pump should be installed as near the liquid source as possible. Excessive pipe lengths and elbows create fluid losses which detract from the overall efficiency of the pump. It is recommended in good practice that the total suction lift (sum of static and dynamic lift) should not exceed 15 feet. Intake porting should never be reduced for the purpose of piping convenience. Reducing the porting on any given size unit will starve the pump and cause cavitation which will result in a form of internal erosion.

## DISCHARGE

Since gear pumps are positive displacement, care must be taken with the use of restrictive devices such as gate valves in discharge line for purpose of throttling. Accidental closing of discharge line can cause extreme over pressure which may result in serious damage to pump or motor. If discharge line throttling is necessary, selection of pump with built in relief valve should be considered.

For best pump life it is recommended that each unit be primed. Failure to do so may result in excess wear of bearing surfaces and ultimate pump failure due to dry running. Care must be used in the selection of pump material, whether it be brass or cast iron, for the particular fluids being pumped. Our Engineering Department will assist in this matter if there is any doubt. However, all fluids must be free of all abrasives such as sand, silt and wettable powders.

Shertech gear pumps are designed to rotate in either direction. When looking at the drive end, and the pump rotation clockwise, the discharge port is on the right side. For opposite rotation, the discharge port is on the left side. With pumps having pressure relief valve, their location is always on the discharge side.

Pressure relief valve functions as a protection for both the pump and system by providing a fluid bypass in the event of overload. The valve setting may be increased by turning the valve stem clockwise. For reducing system pressure, turn valve stem counterclockwise.

## MAINTENANCE

Pump should be drained if media pumped is subject to freezing. Periodic lubrication on pumps with grease fittings is mandatory after 100 hours of operation. Flush pump with clear fluid prior to storage to remove contaminate buildup in bearing areas.

**PARTS LIST FOR MODEL BB BRONZE ROTARY GEAR PUMPS**

DESCRIPTION	BB1	BB2	BB3	BB4	BB5	BB6
BODY ASSY	11540	11482	11538	11539	11497	11501
COVER	11476	11788	11488	11488	11495	11495
DRIVE GEAR/SHAFT ASSY	11550	11545	11546	11553	11548	11555
DRIVEN GEAR/SHAFT ASSY	11579	11560	11559	11558	11557	11556
GASKET	17615	09878	00252	00252	05486	05486
PACKING	11677	11693	11694	11694	11694	11694
PACKING NUT	11523	11524	11525	11525	11525	11525
BUSHING	(3) 10273	(3) 02075	(3) 06333	(3) 06333	(3) 06333	(3) 06333
BUSHING	(1) 11517	(1) 11518	(1) 11519	(1) 11519	(1) 11519	(1) 11519
SCREW	(6) 12686	(7) 12686	(8) 12686	(8) 12686	(8) 12686	(8) 12686

Screws and washers are available from local hardware outlet.

**PARTS LIST FOR MODEL BBV BRONZE ROTARY GEAR PUMPS**

DESCRIPTION	BBV2	BBV3	BBV4	BBV5	BBV6
BODY ASSY	11482	11538	11539	11497	11501
COVER ASSY	11484	11490	11490	11499	11499
DRIVE GEAR/SHAFT ASSY	11545	11546	11553	11548	11555
DRIVEN GEAR/SHAFT ASSY	11560	11559	11558	11557	11556
GASKET	09878	00252	00252	05486	05486
PACKING	11693	11694	11694	11694	11694
PACKING NUT	11524	11525	11525	11525	11525
BUSHING	(3) 02075	(3) 06333	(3) 06333	(3) 06333	(3) 06333
BUSHING	(1) 11518	(1) 11519	(1) 11519	(1) 11519	(1) 11519
SCREW	(7) 12686	(8) 12686	(8) 12686	(8) 12686	(8) 12686
VALVE KIT	12982	12982	12982	12521	12521

**PARTS LIST FOR MODEL C CAST IRON ROTARY GEAR PUMPS**

DESCRIPTION	C1 N	C2N	C3N	C4N	C5N	C6N
BODY ASSY	18827	18828	18829	18832	18833	18834
COVER	11991	11992	11993	11993	11994	11994
DRIVE GEAR/SHAFT ASSY	13355	13356	13357	13358	13359	13360
DRIVEN GEAR/SHAFT ASSY	12028	12030	12032	12034	12036	12038
GASKET	13349	13350	12786	12786	13351	13351
LIP SEAL	9501	11628	10514	10514	10514	10514
PIN	(2) 13297	(2) 13297	(2) 13297	(2) 13297	(2) 13297	(2) 13297
RETAINING RING	13352	13353	13354	13354	13354	13354
BALL	(2) 13296	(2) 13296	(2) 13296	(2) 13296	(2) 13296	(2) 13296
SCREW	(6) 12686	(7) 12686	(8) 12686	(8) 12686	(8) 12686	(8) 12686

OPTIONAL	C2V	C3V	C4V	C5V	C6V
VITON SEAL	11674	11792	11792	11792	11792

Screws and washers are available from local hardware outlet.

DIMENSIONS																					
PUMP NUMBER			A	B	C	D	E	F	G	H	I	J	K	L	M*	M**	N	O	P	Q	R
BB-1	—	C-1	1/8	3/8	7/8	3-15/16	2-11/16	6	9/32	1-13/32	1-1/8	7/8	1-7/8	2-13/16	3/16	1/4	1-3/16	1-7/8	11/16	3/8	—
BB-2	BBV-2	C-2	1/4	1/2	7/8	4-13/32	3-5/32	6-3/32	9/32	1-23/32	1-1/4	1-1/8	2-3/8	3-9/16	3/16	1/4	1-15/32	2-23/64	13/16	15/32	1-3/8
BB-3	BBV-3	C-3	3/8	5/8	1	4-7/8	3-3/8	6-19/32	25/64	1-7/8	1-9/32	1-7/16	2-3/4	4	1/4	5/16	1-13/16	2-5/8	3/4	1/2	1-3/8
BB-4	BBV-4	C-4	1/2	5/8	1	5-5/32	3-21/32	6-31/32	25/64	1-7/8	1-9/32	1-7/16	2-3/4	4	1/4	5/16	1-13/16	2-5/8	3/4	19/32	1-3/8
BB-5	BBV-5	C-5	3/4	5/8	1	5-1/16	3-9/16	6-31/32	25/64	2-9/16	1-1/2	1-5/8	3-3/8	5-3/16	1/4	3/8	2	3-9/16	15/16	11/16	1-27/32
BB-6	BBV-6	C-6	1	5/8	1	5-3/16	3-11/16	7-7/32	25/64	2-9/16	1-1/2	1-5/8	3-1/2	5-3/16	1/4	3/8	2	3-9/16	15/16	13/16	1-27/32

\*Bronze Rotary Gear Pump

\*\*Cast Iron Rotary Gear Pump

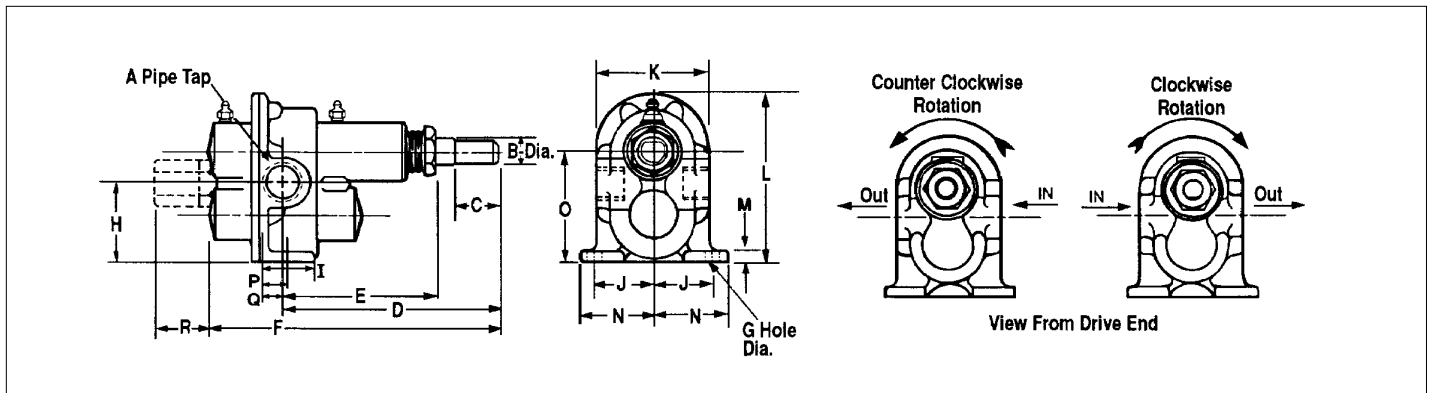

Performance figures show the gallons per minute and the horsepower required at various speeds and pressures for one specific fluid. The type of fluid, viscosity, temperature, specific gravity and piping will vary these data.

In general, slower speeds are required for viscous fluids; the more viscous the fluid, the greater the horsepower required. Fluids of low lubricity require slower pump speeds.

- Selection of a larger pump run at a lower speed is preferred.

- High speeds with high pressures shorten pump life.
- When using electric motors, always select the next highest size.
- Complete performance data covering solids, pressures, materials and viscosities are available on all Shertech pumps. Shertech's sales representatives and engineering staff are available to aid in your pump selection.

PERFORMANCE													
Port Size	Pump RPM	Free Flow		20 PSI		40 PSI		60 PSI		80 PSI		100 PSI	
		GPM*	HP	GPM	HP	GPM	HP	GPM	HP	GPM	HP	GPM	HP
1/8"	900	1.2	.03	1.0	.06	0.8	.09	0.5	.12	0.3	.14	—	—
	1200	1.6	.04	1.3	.07	1.1	.10	0.9	.13	0.6	.16	0.3	.19
	1725	2.2	.09	2.0	.11	1.8	.15	1.5	.19	1.3	.24	1.0	.29
1/4"	900	2.2	.05	1.8	.10	1.5	.16	1.2	.22	1.0	.28	0.8	.34
	1200	2.9	.06	2.5	.12	2.2	.19	2.0	.26	1.8	.33	1.6	.40
	1725	3.8	.14	3.7	.23	3.5	.32	3.2	.40	3.0	.49	2.8	.58
3/8"	900	4.1	.06	3.6	.15	3.2	.24	2.8	.33	2.4	.42	2.1	.51
	1200	5.5	.08	5.0	.19	4.7	.29	4.3	.40	3.9	.50	3.5	.61
	1725	7.0	.18	6.9	.32	6.9	.47	6.8	.61	6.8	.75	6.6	.89
1/2"	900	5.4	.10	4.9	.21	4.4	.32	4.0	.43	3.6	.54	3.3	.66
	1200	7.5	.15	7.0	.28	6.5	.41	6.0	.54	5.6	.67	5.2	.80
	1725	11.3	.27	10.8	.45	10.3	.63	9.9	.81	9.5	.99	9.3	1.17
3/4"	900	10.3	.25	9.8	.41	9.4	.58	9.0	.74	8.7	.90	8.4	1.06
	1200	13.8	.32	13.3	.55	13.0	.77	12.6	1.00	12.4	1.23	12.2	1.45
	1725	19.9	.76	19.6	1.07	19.4	1.38	19.2	1.68	19.0	2.00	18.9	2.30
1"	900	12.5	.28	12.3	.46	12.1	.64	11.9	.82	11.6	1.00	11.3	1.18
	1200	16.6	.35	16.4	.59	16.3	.84	16.1	1.08	15.9	1.33	15.5	1.57
	1725	24.0	.83	24.0	1.14	24.0	1.46	23.9	1.78	23.8	2.10	23.7	2.42

Flows and horsepower data shown are for a liquid having a viscosity of 35 S.S.U. at 70°F.

Example: Water and No. 1 fuel oil are 35 S.S.U. Cast iron pumps are not recommended for water.

### ***Limited Warranty***

The Industrial Products Division of Hypro warrants to the original consumer purchaser of its Shertech pumps that they will be free of defects in workmanship, or materials under normal use for 90 days from the date of purchase. This limited warranty does not cover any defect, malfunction, or failure caused by or resulting from improper or unauthorized service maintenance, installation, repair, or use not within the working specifications for which the pump was designed, or from abuse, tampering with, neglect, opening, accident or any other cause beyond the control of Hypro. This limited warranty is made only to the original consumer purchaser and is effective only upon presentation of evidence of provable date of purchase.

No person, agent, distributor, dealer, service facility, or company is authorized to change, modify or amend the terms of this limited warranty in any manner or fashion whatsoever. Except, and to the extent provide herein. Hypro make no warranty, either expressed or implied including any warranty of merchantability or fitness for a particular purpose, and all such implied warranties are limited to the duration of the expressed warranties herein.

Liability in all events is limited to the purchase price paid and liability under the aforesaid warranty is limited to replacing or repairing any parts which are defective in materials, or workmanship and returned to an authorized service location, as we designate, shipping costs prepaid.



**INDUSTRIAL PRODUCTS GROUP**

375 Fifth Avenue NW • New Brighton, MN 55112-3266 • (651) 766-6300  
Phone: 1-800-471-0460 • Fax: 1-800-672-7023  
[www.hypropumps.com](http://www.hypropumps.com)