

Motor Connection Diagrams

3 Phase NEMA Motors

3 Phase - YY/Y - 9 Lead

4,1 Blue / 5,2 White / 6,3 Org / 7 Y1 / 8 Blk / 9 RD
 Cast Iron- 1,2,3 Top - 4,5,6,7,8,9 Bottom
 Aluminum - 4,5,6,8,9 Top - 1,2,3,7 Bottom

3 Phase - Δ/ΔΔ - 12 Lead

T1 & T4: Blue / T2 & T5: White / T8 & T11: Black
 T9 & T12: Red / T3 & T6: Orange / T7 & T10: Yellow
 1,2,3,7,8,9 Top - 4,5,6,10,11,12 Bottom

3 Phase - Single Voltage

T1 & T4: Blue / T2 & T5: White
 T3 & T6 Orange
 1,2,3 Top - 4,5,6 Bottom

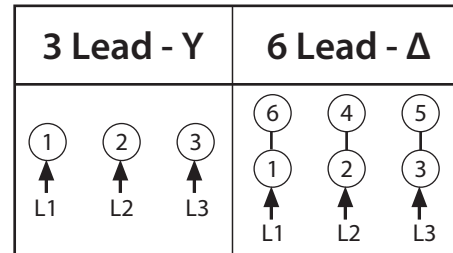
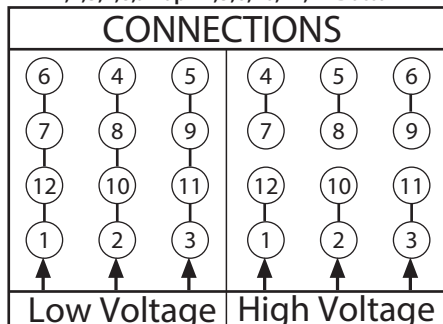
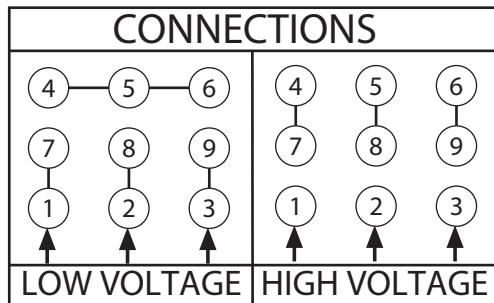

3 Phase - Δ/ΔΔ/Y - 12 Lead - Tri-Voltage

Lead Color and location are the same as 12 lead above

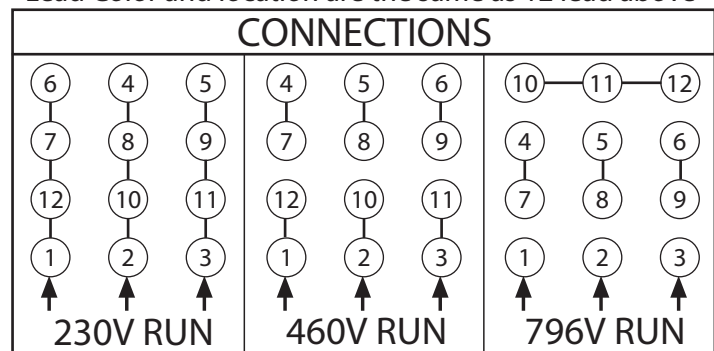

Single Phase - NEMA

Dual Voltage - RD1 Line

P1: Blue / P2 & T5: Black / T2: White
 T3: Orange / T8: Red

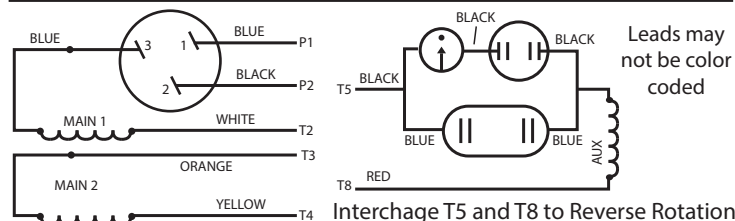
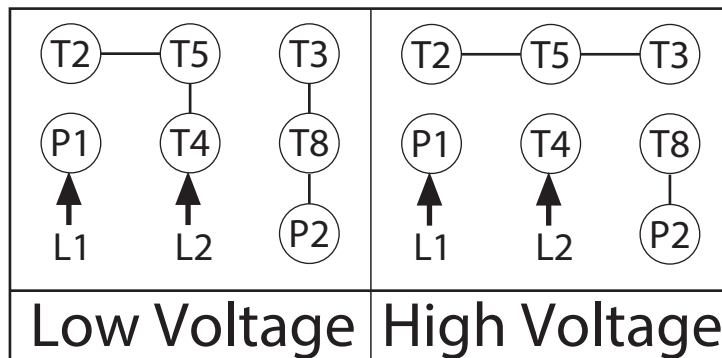

3 Phase IEC MOTORS

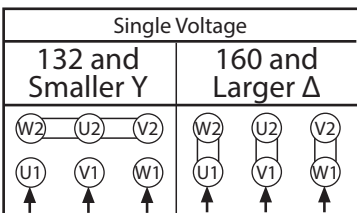
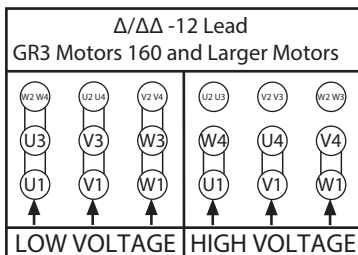
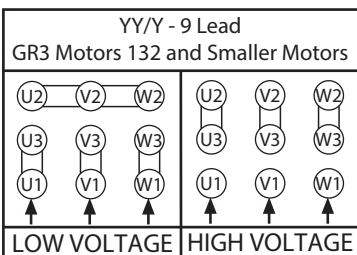

Distributed by:
 PumpBiz, Inc
 800-PumpBiz (786-7249)
www.PumpBiz.com

Single Voltage - RD1 Line - Frame 182T - 215T

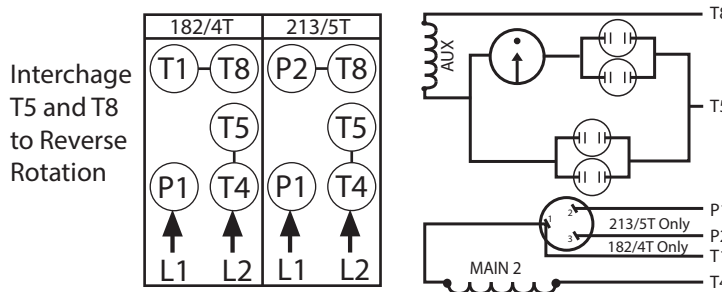

When Motor is in F1 position, leads indicated as "TOP" exit the casing above the center line of the motor and those indicated as "Bottom" exit below the center line. This information can be used to identify missing or mislabelled leads.