

EVMSU, EVMUG/L - Vertical Multistage Pumps

Data Book 60Hz



CONTENTS

SECTION	PAGE
FEATURES	2
TYPICAL APPLICATIONS	3
MODEL DESIGNATION	4
PRODUCT SPECIFICATIONS	
EVMSU1 – EVMSU20	5
EVMU32 - EVMU64	6
CURVE SPECIFICATIONS	7
PERFORMANCE RANGE	8
SELECTION CHART	9
PERFORMANCE CURVES	
EVMSU1	11
EVMSU3	12
EVMSU5	13
EVMSU10	14
EVMSU15	15
EVMSU20	16
EVMU32	17
EVMU45	18
EVMU64	19
SHAFT SEAL	20
MECHANICAL SEAL	21
TECHNICAL DATA – DIMENSIONS	
EVMSU1	22
EVMSU3	23
EVMSU5	24
EVMSU10	25
EVMSU15	26
EVMSU20	27
EVMU32 - EVMU64	30
MOTOR DIMENSION	28
SECTIONAL VIEW AND PARTS REFERENCE	
EVMSU1	34
EVMSU3	38
EVMSU5	42
EVMSU10	46
EVMSU15	50
EVMSU20	54
EVMU32	58
EVMU45 - EVMU64	60



Note: Models EVMSU/EVMSUL 1-20 and EVMUG/EVMUL 32-64 certified to NSF/ANSI 61 & 372.

Certified to
NSF/ANSI 61, ANNEX G

All specifications subject to change without notice.



EBARA

EBARA International Corporation, Fluid Handling Division
www.pumpsebara.com

FEATURES**EVMSU 1-20**



- Standard NEMA motor sizes
- Low axial thrust impeller enables long motor bearing life
- Air vent in casing cover allows proper venting preventing air entrapment and dry run
- Fill port in casing cover allows for water fill, as well as installation of sensors, gauges, and other measuring devices
- Liner ring is a self-aligning, floating design constructed to prevent swelling at high temperatures
- Tungsten carbide lower pump bearings and sleeves are standard construction for all services, providing maximum operating life
- Direct drive pump and motor shafts are keyed for positive, reliable power transmission with no adjustments necessary
- “Flexible” floating outer casing allows for thermal expansion in hot water applications, preventing deformation due to pressure fluctuations
- Square-edge four spline shaft provides positive location and drive of impellers, eliminating wear
- Dimensions & flanges – installation is to market accepted dimensions for easy upgrade of existing installations
- Piping connection options include Fixed ANSI compatible flange, Oval flange, Loose ANSI compatible flange, victaulic, and clamp connections
- Mechanical seal – Silicon Carbide/Carbon/Viton mechanical shaft seal. Cartridge mechanical seal design enables replacement without disassembling the motor bracket

EVMU 32-64

- Standard NEMA motor sizes
- Integral thrust bearing to handle axial thrust loads
- Air vent in casing cover allows proper venting preventing air entrapment and dry run
- Liner ring is a self-aligning, floating design constructed to prevent swelling at high temperatures
- Tungsten carbide lower pump bearings and sleeves are standard construction for all services, providing maximum operating life
- Direct drive pump and motor shafts are keyed for positive, reliable power transmission with no adjustments necessary
- “Flexible” floating outer casing allows for thermal expansion in hot water applications, preventing deformation due to pressure fluctuations
- Anti-erosion measures – a dish-shaped insert is fitted to the intermediate casing designed to promote smooth flow and prevent high velocity areas that accelerate erosion
- Square-edge twelve spline shaft (EVMU 32-64) provides positive location and drive of impellers eliminating wear
- Dimensions & flanges – installation is to market accepted dimensions for easy upgrade of existing installations
- Mechanical seal – Silicon Carbide/Carbon/Viton mechanical shaft seal. Cartridge mechanical seal design enables replacement without disassembling the motor bracket.



TYPICAL APPLICATIONS

INDUSTRY	BUILDING SERVICE	WATER SUPPLY
		
<ul style="list-style-type: none"> • Water treatment reverse osmosis ultra-filtration water purification micro-filtration softening, ionizing and demineralising systems swimming pools separators • Boiler feed steam systems condensate systems • Wash and clean vehicle washing systems industrial part washing laundry systems supply of liquids with acids and bases supply of chemical liquids • Chilling handling of refrigerants for cooling thermal control systems industrial cooling laser cooling • Machine tool cooling lubricant supply for machine tools • Pressure boosting pressure boosting for industrial use • Food & beverage food washing systems bottle wash systems • Pharmaceutical industries • Marine applications freshwater, deckwash, high fog and fire fighting on ships 	<ul style="list-style-type: none"> • Pressure boosting pressure boosting for buildings pressure boosting for high rise buildings/hotels • Sprinkler systems • Fire fighting systems jockey pump • District heating • Heat exchangers / fan heaters • Air conditioning systems • Heating systems 	<ul style="list-style-type: none"> • Water treatment water treatment plants filtration water treatment plants transfer • Pressure boosting transfer from water treatment plants (mains) • Irrigation golf course / sport fields irrigation • Agriculture sprinkler irrigation drip irrigation

MODEL DESIGNATION

Models EVMSU 1, 3, 5, 10, 15, 20
 EVMSUL 1, 3, 5, 10, 15, 20

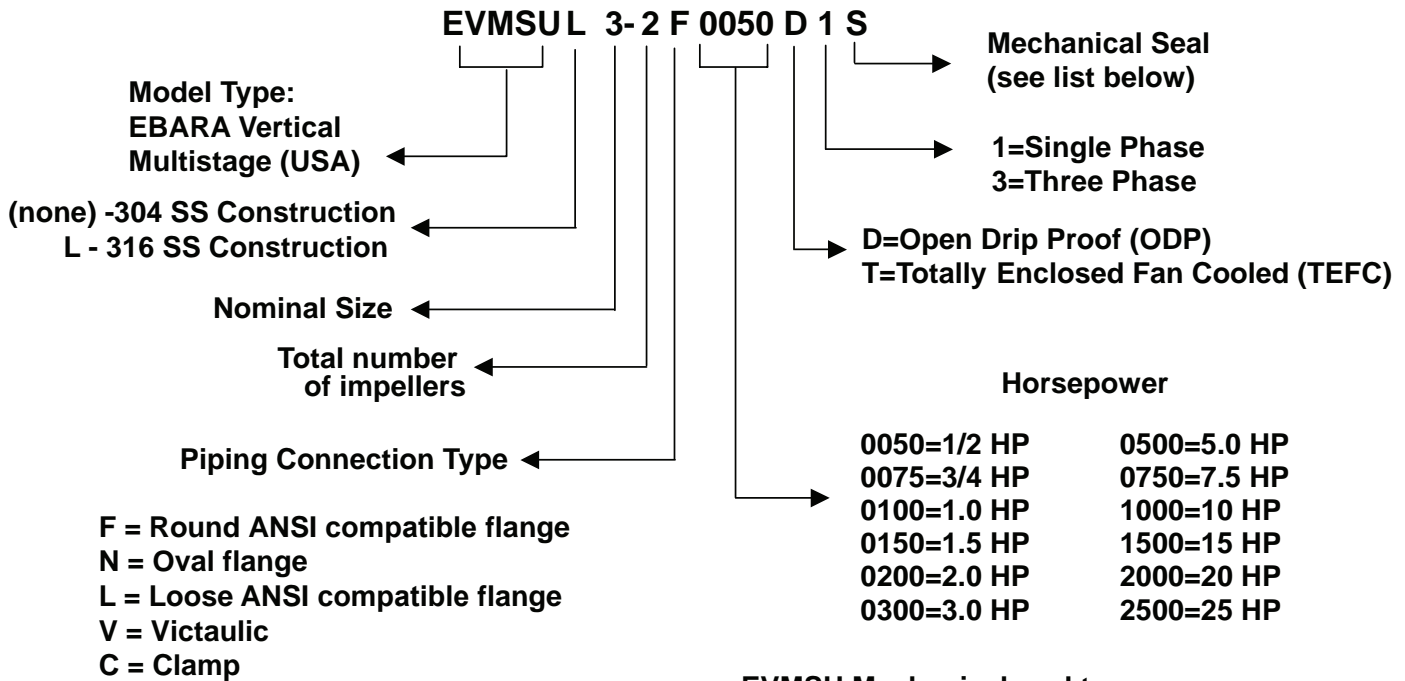

EVMSU Mechanical seal type

- S = Silicon Carbide/Carbon/FPM*
- G = Silicon Carbide+Graphite/Silicon Carbide/FPM
- E = Silicon Carbide/Carbon/EPDM
- R = Silicon Carbide+Graphite/Silicon Carbide/EPDM
- B = Silicon Carbide/Carbon/EPDM (optional balanced seal)
- X = Special order seal materials (consult factory)

*NSF/ANSI 61 & 372 certified configuration

Models EVMUG 32, 45, 64
 EVMUL 32, 45, 64

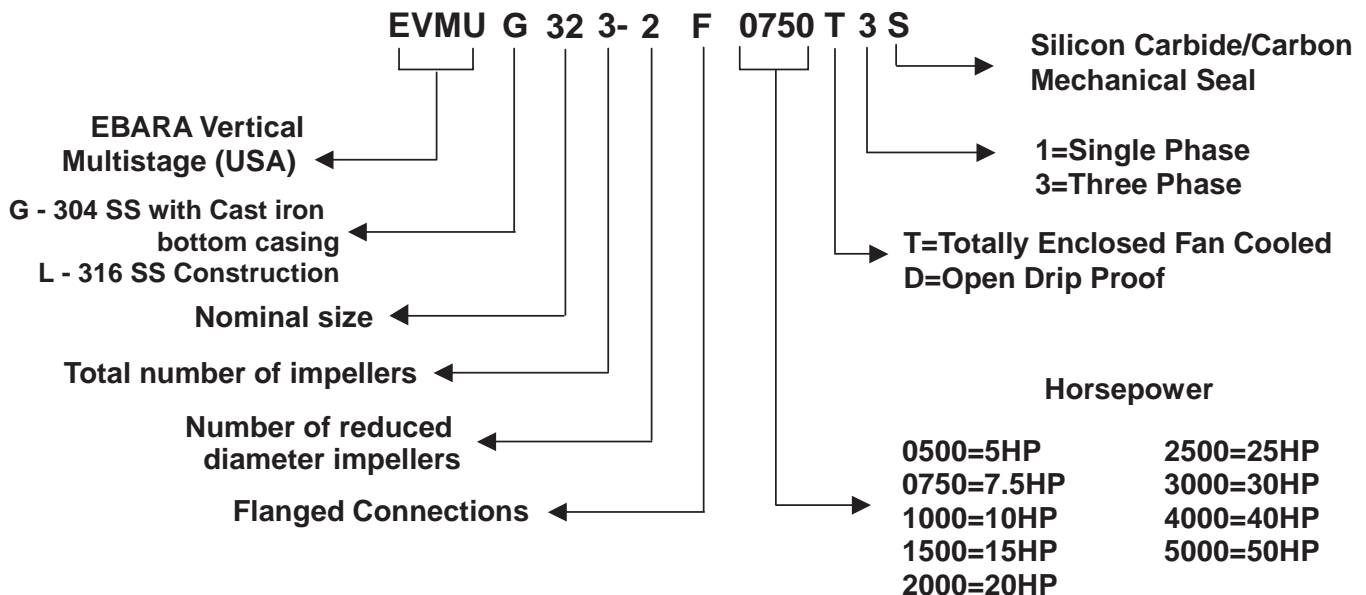

PRODUCT SPECIFICATIONS
EVMSU(L)1-3-5-10-15-20

PUMP														
Version		EVMSU						EVMSUL						
Performance range	Nominal size	1	3	5	10	15	20	1	3	5	10	15	20	
	HP	1/2 to 25 HP												
	Capacity	2.9 to 132.1 gpm												
	Head	24.3 to 860 ft TDH												
Liquid Handling	Type of liquid	Clean water (<i>for other clean liquids, consult factory</i>)												
	Maximum working pressure	230 / 360 PSI (530 / 830 ft TDH)												
	Liquid temperature range	-22°F to 248°F (-30°C to 120°C)												
Size	Suction	1 1/4"			2"			1 1/4"			2"			
	Discharge	1 1/4"			2"			1 1/4"			2"			
Key Component Materials	Impeller	AISI 304 (EN 1.4301)						AISI 316 (EN 1.4401)						
	Intermediate casing	AISI 304 (EN 1.4301)						AISI 316 (EN 1.4401)						
	Liner ring	AISI 304 (EN 1.4301) + PPS						AISI 316 (EN 1.4401) + PPS						
	Bottom casing	AISI 304 (EN 1.4301)						AISI 316 (EN 1.4401)						
	Casing cover	AISI 304 (EN 1.4301)						AISI 316 (EN 1.4401)						
	Shaft	AISI 304 (EN 1.4301)	EVMSU 1-3-5, EVMSU 10-15-20 (depending on model)											
		AISI 316L (EN 1.4404)	EVMSUL 1-3-5, EVMSUL 10-15-20 (depending on model)											
		AISI 329A (EN 1.4462)	EVMSU / EVMSUL 5-15-20 (depending on model)											
	Shaft sleeve bearing	Tungsten carbide												
	Shaft Seal	Silicon Carbide / Carbon / FPM (standard)												
	O-ring	EPDM	○	○	○	○	○	○	○	○	○	○	○	○
		FPM	●	●	●	●	●	●	●	●	●	●	●	●
	Outer casing	AISI 304 (EN 1.4301)						AISI 316L (EN 1.4404)						
	Motor bracket	Cast Iron												
	Tie rod	Galvanized steel 6.8 strength class ISO 898/1												
Coupling	up to 5 HP	Die cast aluminium												
	from 7 1/2 HP	Cast Iron												
Base	Die cast aluminium													
Pipe connection	Oval flange	up to 230 PSI	○	○	○	○	○	○	○	○	○	○	○	○
	Round flange (ANSI compatible)	up to 230 PSI	●	●	●	●	●	●	●	●	●	●	●	●
		from 230 PSI to 360 PSI	●	●	●	●	●	●	●	●	●	●	●	●
	Loose round flange (ANSI compatible)	up to 230 PSI	○	○	○	○	○	○	○	○	○	○	○	○
		from 230 PSI to 360 PSI	○	○	○	○	○	○	○	○	○	○	○	○
	victaulic	up to 230/360 PSI	○	○	○	○	○	○	○	○	○	○	○	○
Clamp	up to 230/360 PSI	○	○	○	○	○	○	○	○	○	○	○	○	
Motor	Type	NEMA C/TC/TSC frame, TEFC enclosure												
	Speed	2-pole, 60 Hz, 3500 RPM												
	Power Requirements	3 Phase, 230/460V or 208-230/460V - Single Phase, 115/230V												
	Direction of Rotation	Clockwise when viewed from motor end												
	Motor Options	<i>Consult factory for optional motor types</i>												

Legend: ● Standard ○ Options

PRODUCT SPECIFICATIONS
EVMUG 32, 45, 64
EVMUL 32, 45, 64

	EVMUG	EVMUL
Size		
Suction	ANSI compatible raised face 2 ½" for EVMUG32 3" for EVMUG45 4" for EVUMG64	
Discharge	ANSI compatible raised face 2 ½" for EVMUG32 3" for EVMUG45 4" for EVUMG64	
Range of HP	5 to 50HP	
Range of Performance	at 3450 RPM	
Capacity	66 to 390 GPM	
Head	44 to 930 feet	
Liquid handled		
Type of liquid	Clean water (<i>for other clean liquids, consult factory</i>)	
Temperature	5° to +248°F (-15° to 120°C)	
Working pressure	to 440 PSI (30 Bar) max. (<i>see page 21 for specifics</i>)	
Materials		
Impeller	AISI 304	AISI 316
Intermediate casing	AISI 304	AISI 316
Bottom casing	Cast iron	AISI 316
Casing cover	Cast iron	AISI 316
Outer casing	AISI 304	AISI 316
Shaft	AISI 316	AISI 316
Liner ring	PTFE/AISI 316	
Motor bracket	Cast iron	Cast iron/316
Base	Cast iron	Cast iron/316
Pump Bearing	Thrust Bearing : Sealed Ball Bearing Radial Bearing in wet end: Tungsten Carbide	
Shaft Seal		
Mechanical seal	Silicon/Carbide/Carbon/FPM	
Motor		
Type	NEMA TC/TSC frame	<i>Consult factory for optional motor types</i>
Speed	60 Hz, 3450 RPM (2 poles)	
Three Phase	208-230/460V	
Direction of Rotation	Clockwise when viewed from motor end	
Test standard	ISO 9906 annex A	

Note: Models EVMSU/EVMSUL 1-20 and EVMUG/EVMUL 32-64 certified to NSF/ANSI 61 & 372.

CURVE SPECIFICATIONS

The specifications below qualify the curves shown on the following pages.

- The curves refer to effective speed of 3500 rpm for 2-pole asynchronous motors at 60 Hz.
- Measurements were carried out with clean water at 68 °F of temperature and with a kinematic viscosity of $\nu = 1 \text{ mm}^2/\text{s}$ (1 cSt)
- The NPSH curve is an average curve obtained under the same conditions as the performance curves.
- The recommended operating range for best efficiency is indicated by the continuous portion of each curve.

Symbols explanation:

Q = volume flow rate

H = total dynamic head (TDH)

P2 = pump power input (shaft power)

η = pump efficiency

NPSH = net positive suction head required by the pump



PERFORMANCE RANGE

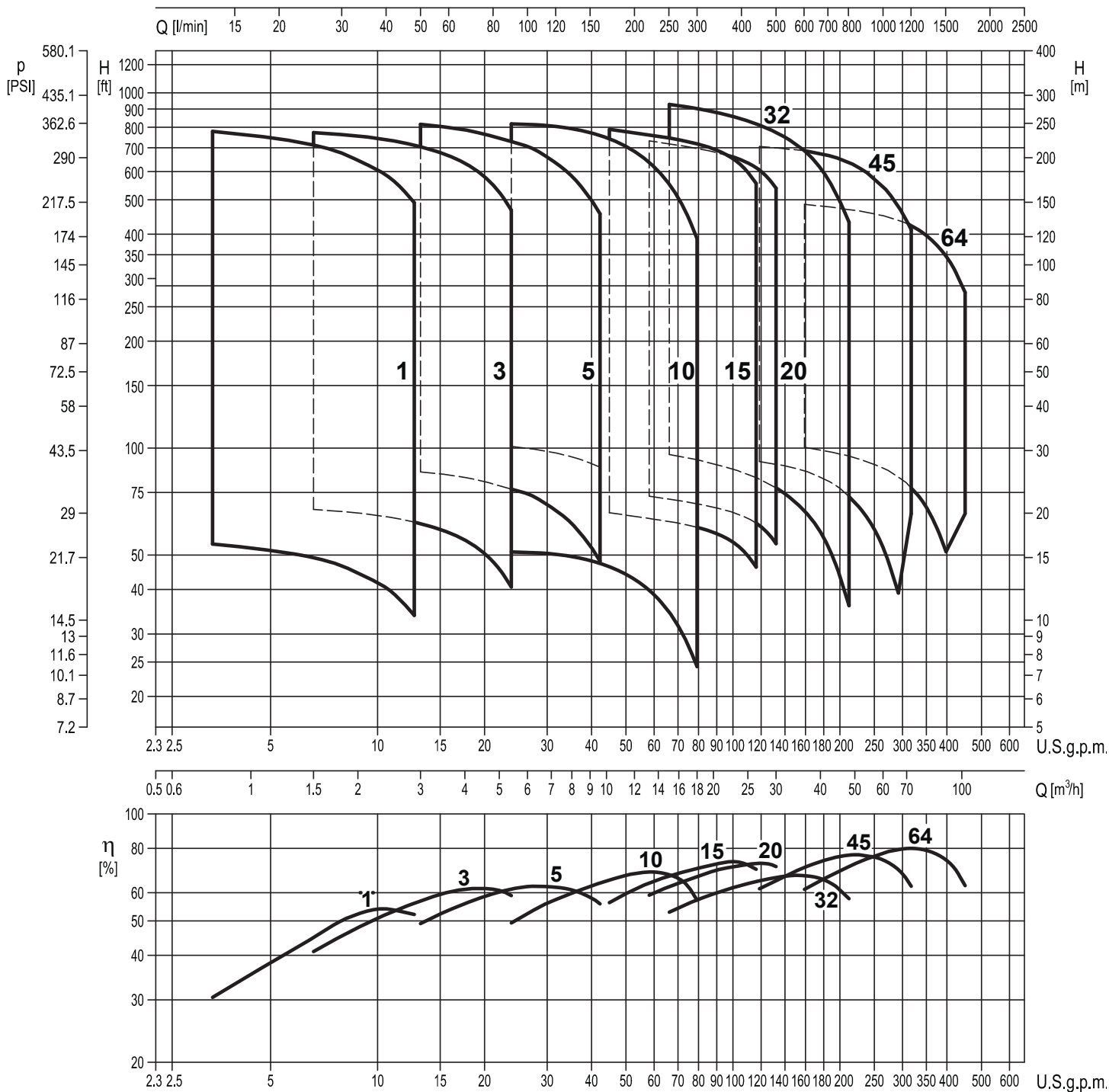

PERFORMANCE CURVES

EVMSU1 1/2HP - 3HP

EVMSU1 2 - EVMSU1 29

Nominal Speed: 3500 RPM

300# ANSI Compatible 1 1/4" 4-Bolt

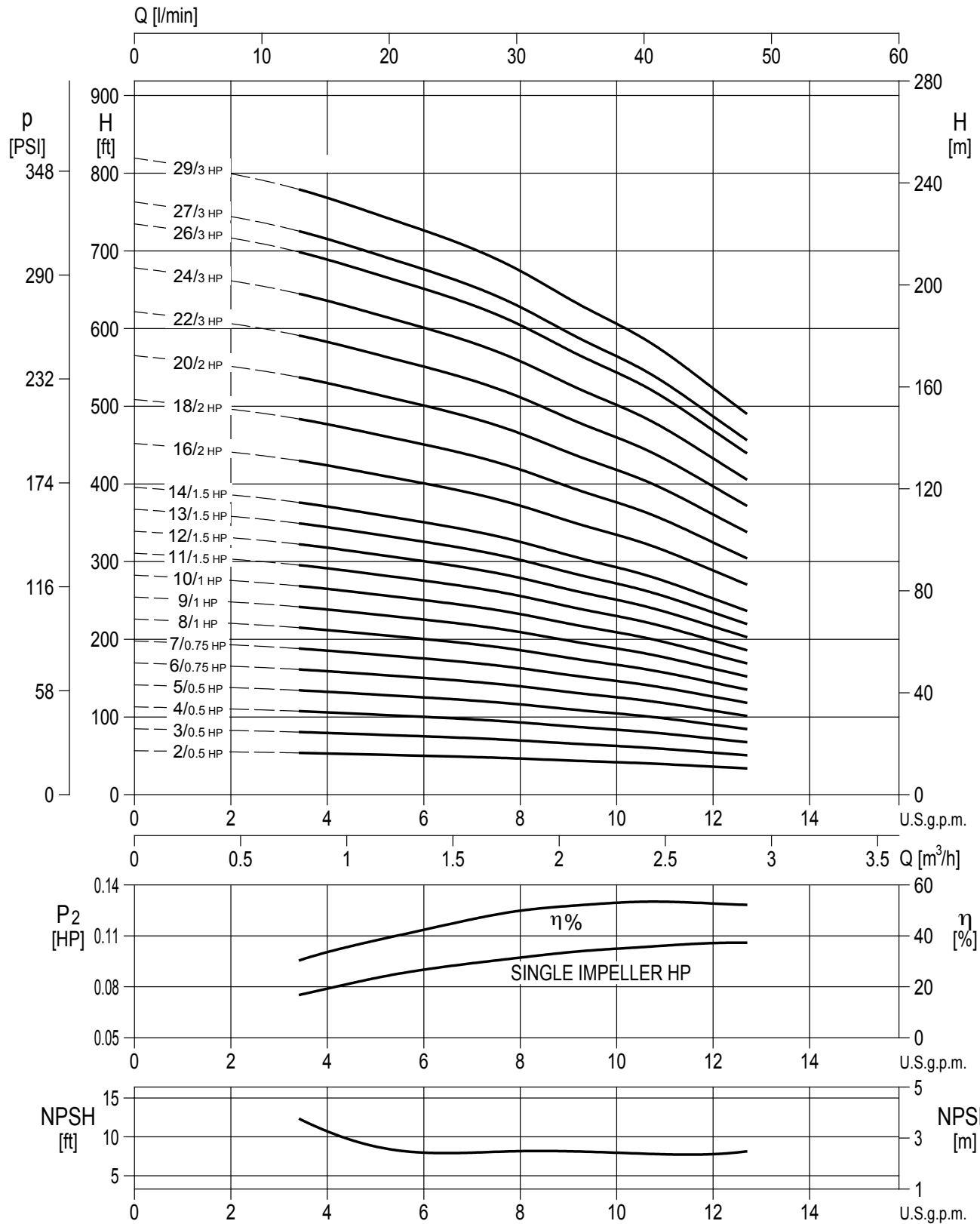

PERFORMANCE CURVES

EVMSU3 1/2HP - 5HP

EVMSU3 2 - EVMSU3 23

Nominal Speed: 3500 RPM

300# ANSI Compatible 1 1/4" 4-Bolt

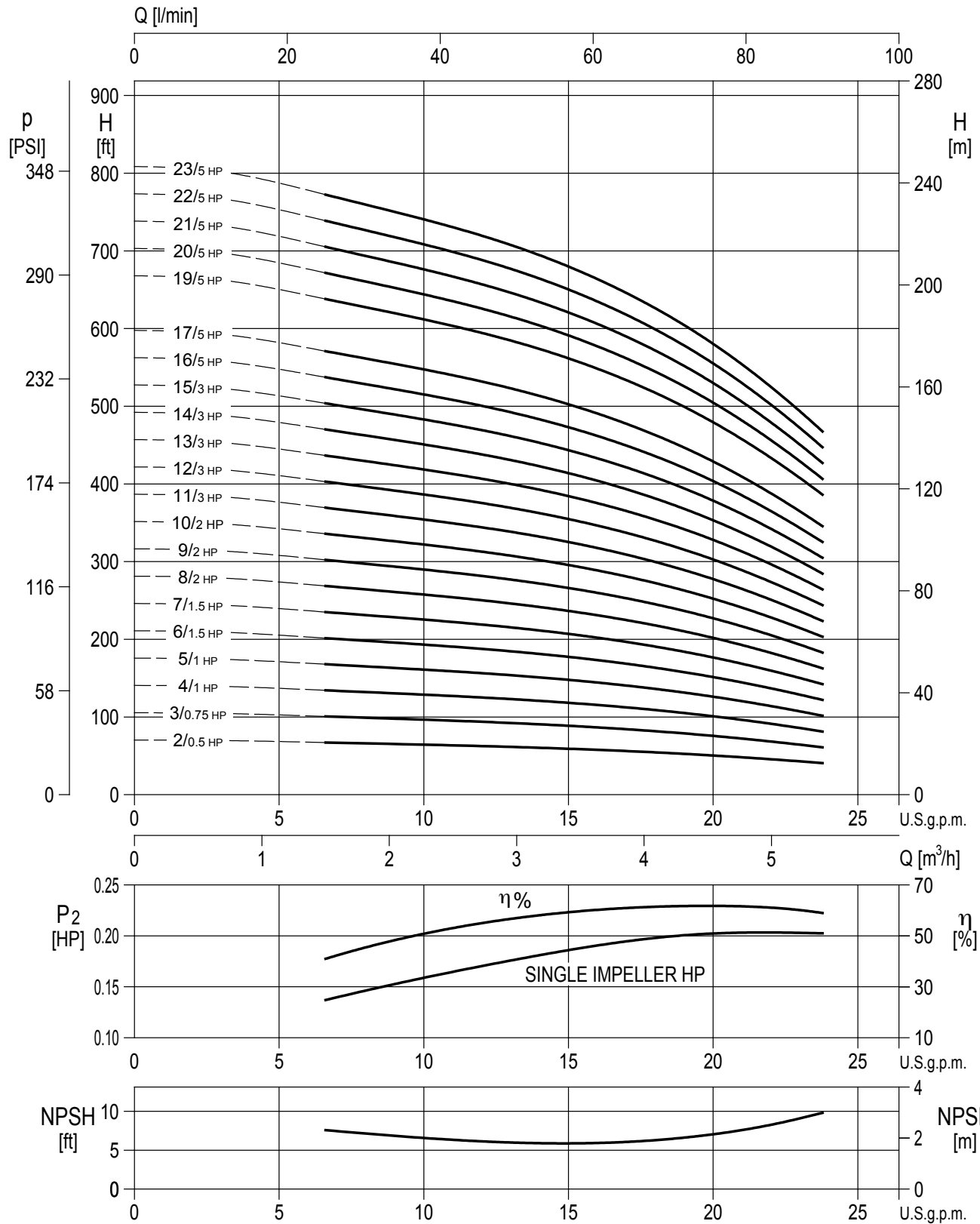

PERFORMANCE CURVES

EVMSU5 1HP - 10HP

EVMSU5 2 - EVMSU5 19

Nominal Speed: 3500 RPM

300# ANSI Compatible 1 1/4" 4-Bolt

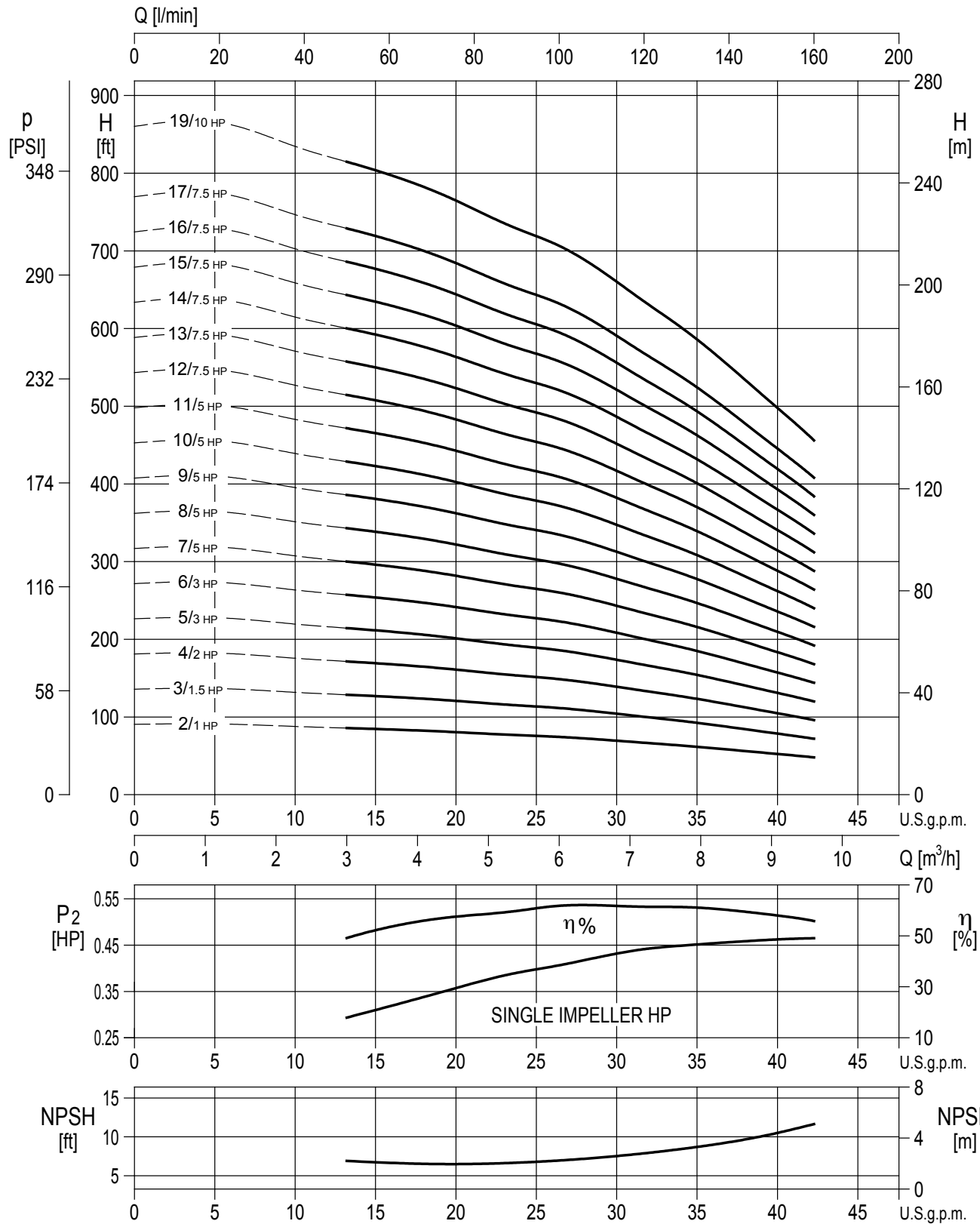

PERFORMANCE CURVES

EVMSU10 1HP - 15HP

EVMSU10 1 - EVMSU10 16

Nominal Speed: 3500 RPM

300# ANSI Compatible 2" 8-Bolt

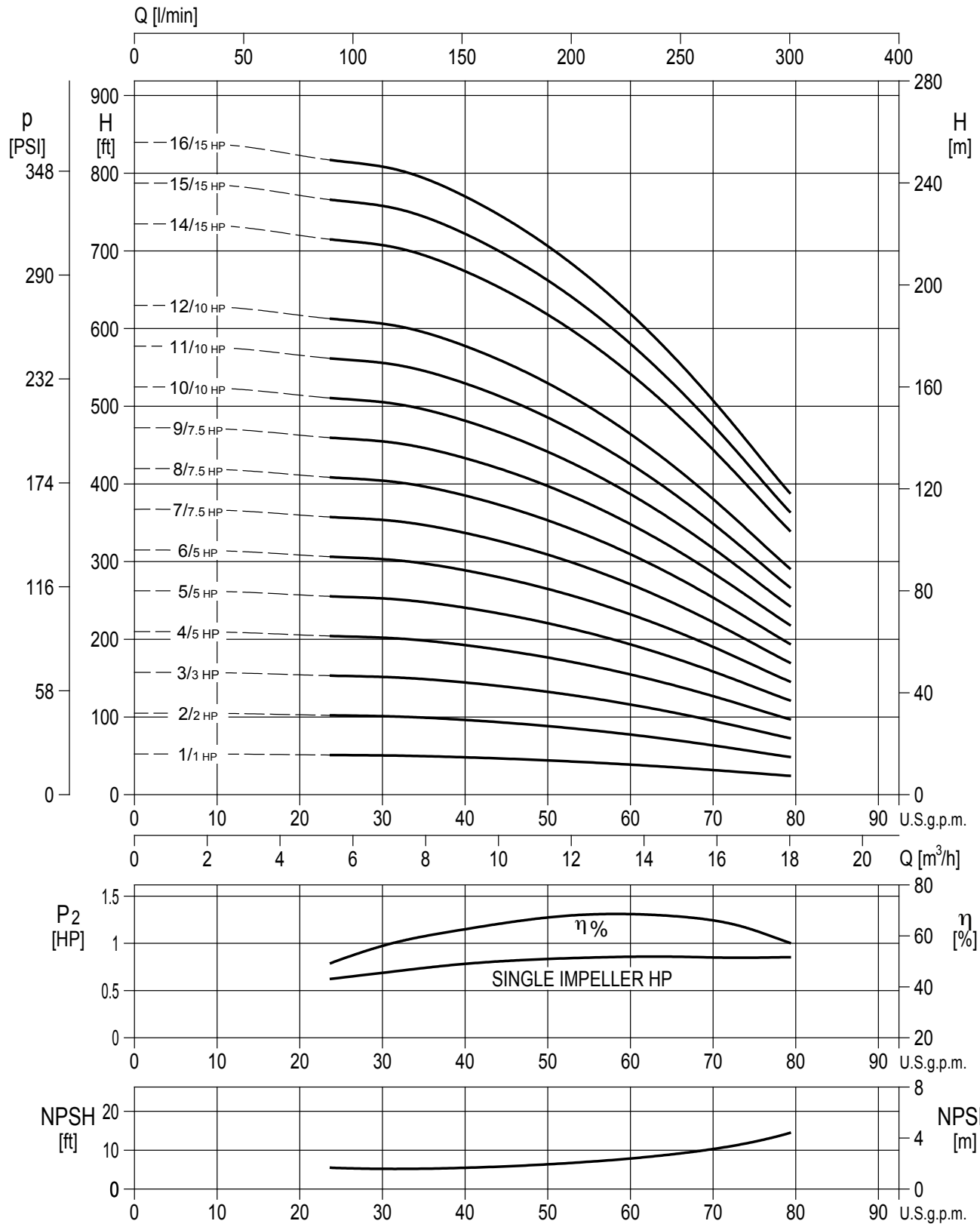

PERFORMANCE CURVES

EVMSU15 2HP - 25HP

EVMSU15 1 - EVMSU15 12

Nominal Speed: 3500 RPM

300# ANSI Compatible 2" 8-Bolt

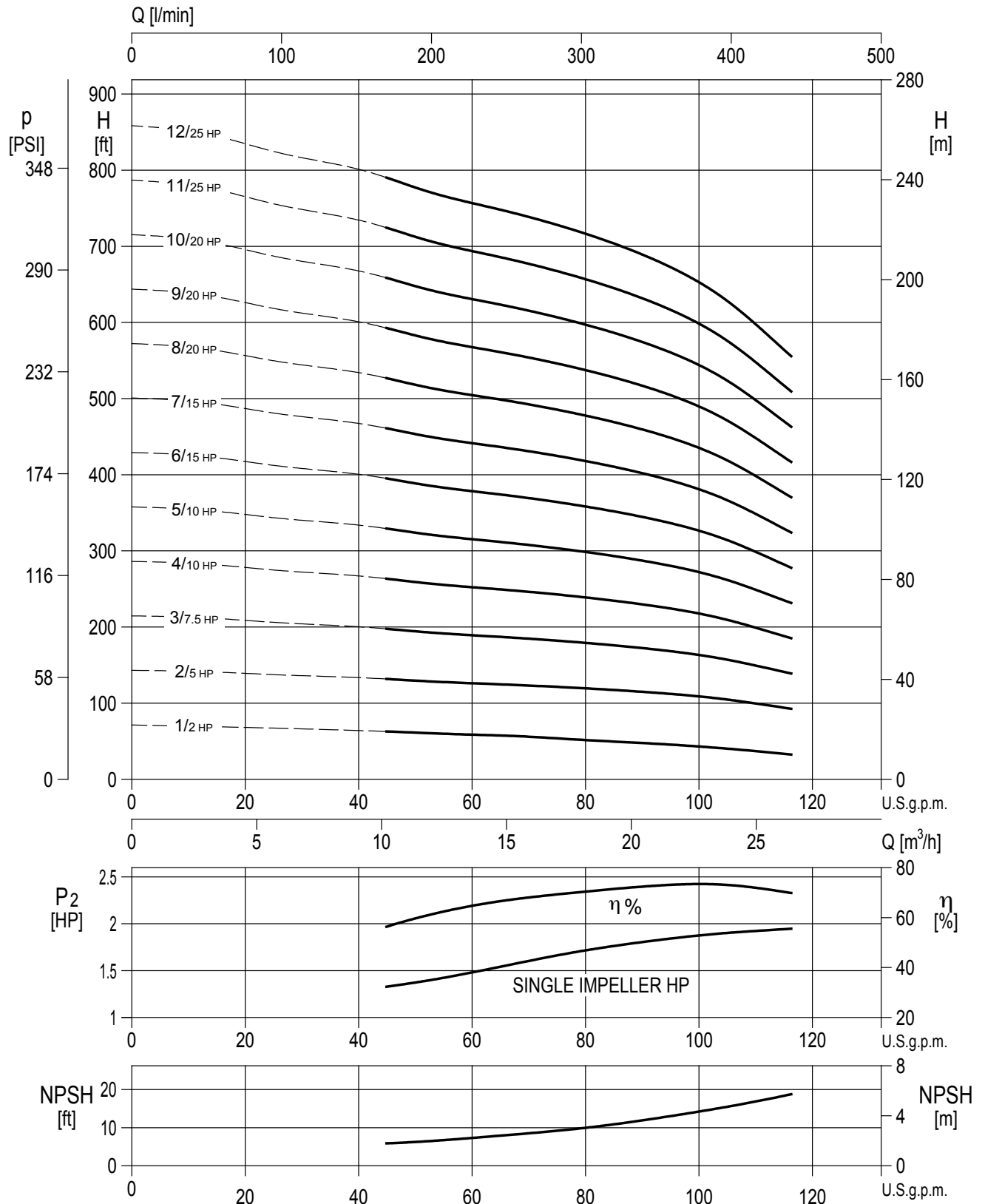

PERFORMANCE CURVES

EVMSU20 3HP - 25HP

EVMSU20 1 - EVMSU20 10

Nominal Speed: 3500 RPM

300# ANSI Compatible 2" 8-Bolt

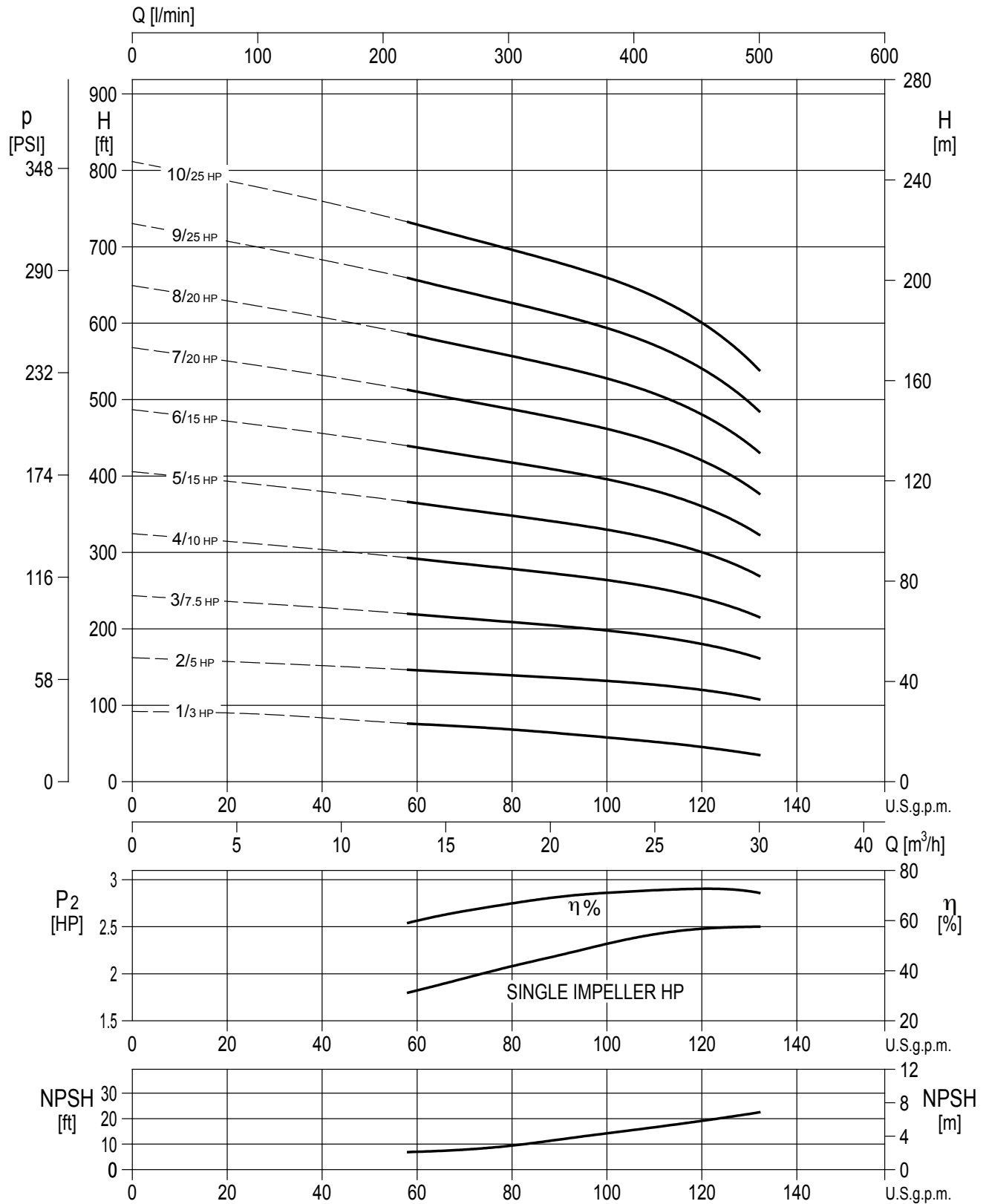

PERFORMANCE CURVES

EVMU32 5HP - 40HP

EVMU32 1 – EVMU32 4-3

Nominal Speed: 3450 RPM

150# ANSI Compatible 2½" 4-Bolt

EVMU32 5 – EVMU32 10-1

Nominal Speed: 3450 RPM

300# ANSI Compatible 2½" 8-Bolt

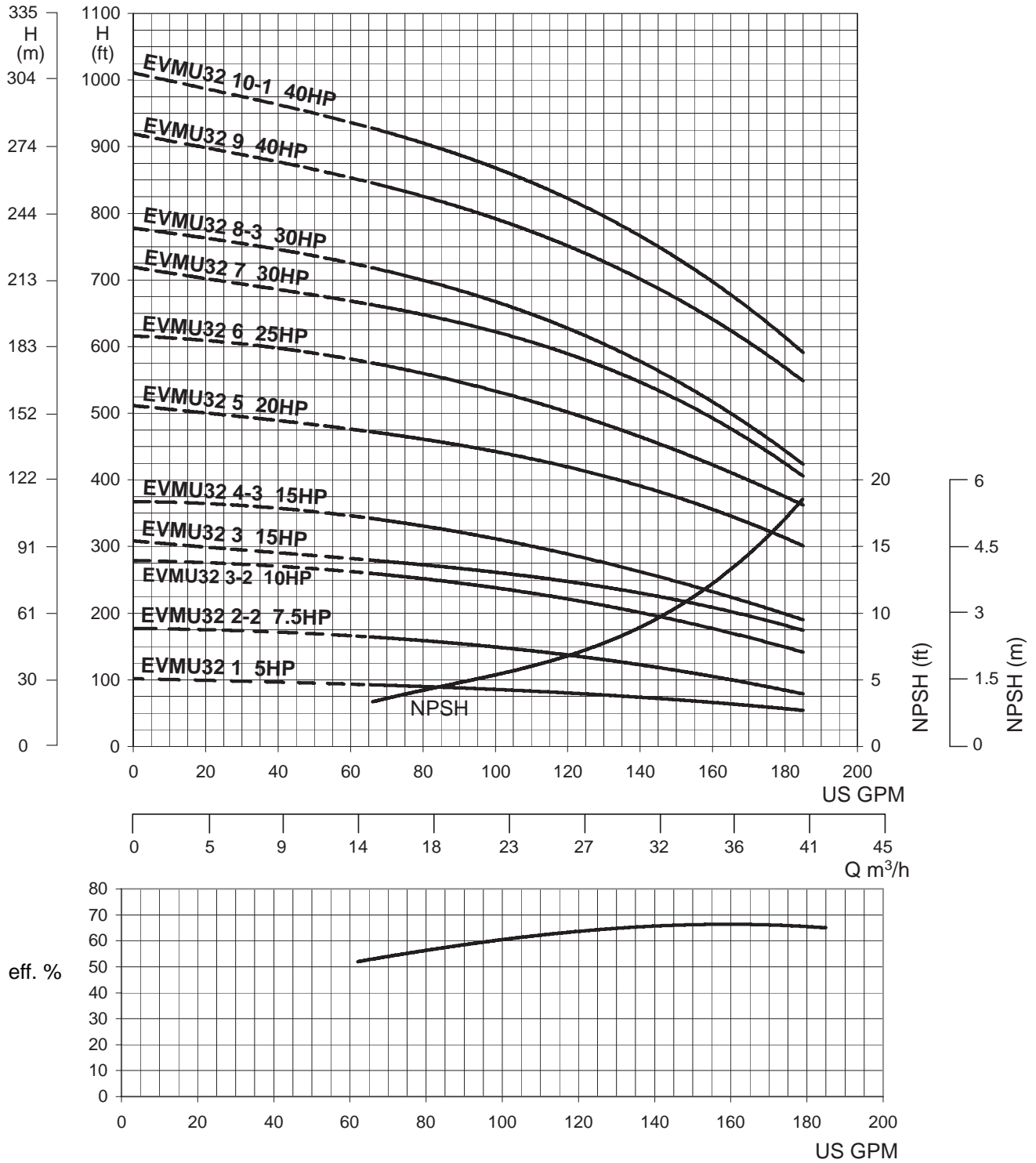

Water Temperature: 20° C (68° F)

PERFORMANCE CURVES

EVMU45 7.5HP - 50HP

EVMU45 1-1 – EVMU45 3

Nominal Speed: 3450 RPM

150# ANSI Compatible 3" 4-Bolt

EVMU45 4-1 – EVMU45 7-2

Nominal Speed: 3450 RPM

300# ANSI Compatible 3" 8-Bolt

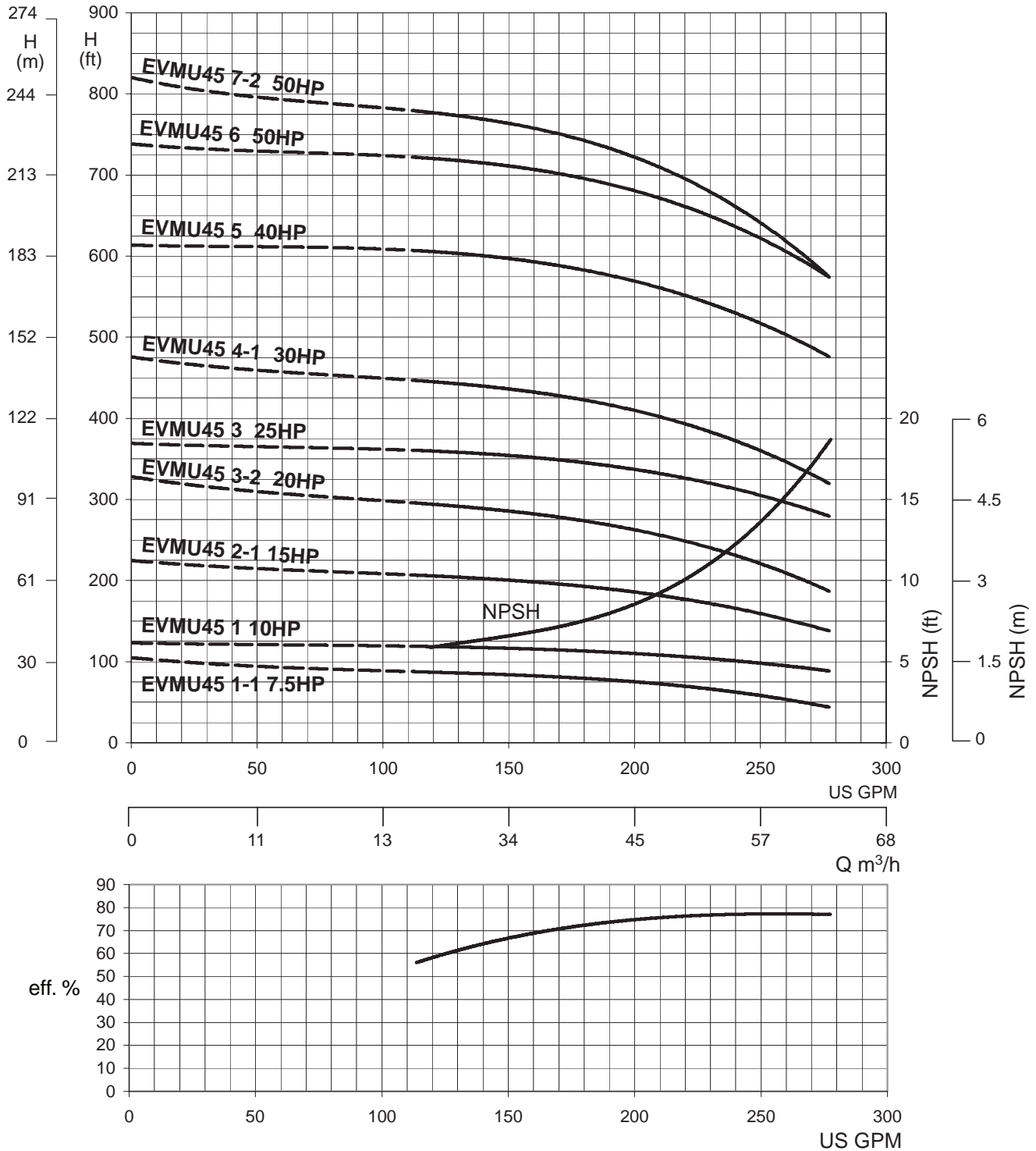

Water Temperature: 20° C (68° F)

PERFORMANCE CURVES

EVMU64 10HP - 50HP

EVMU64 1-1 – EVMU64 3

Nominal Speed: 3450 RPM

150# ANSI Compatible 4" 8-Bolt

EVMU64 4-2

300# ANSI Compatible 4" 8-Bolt

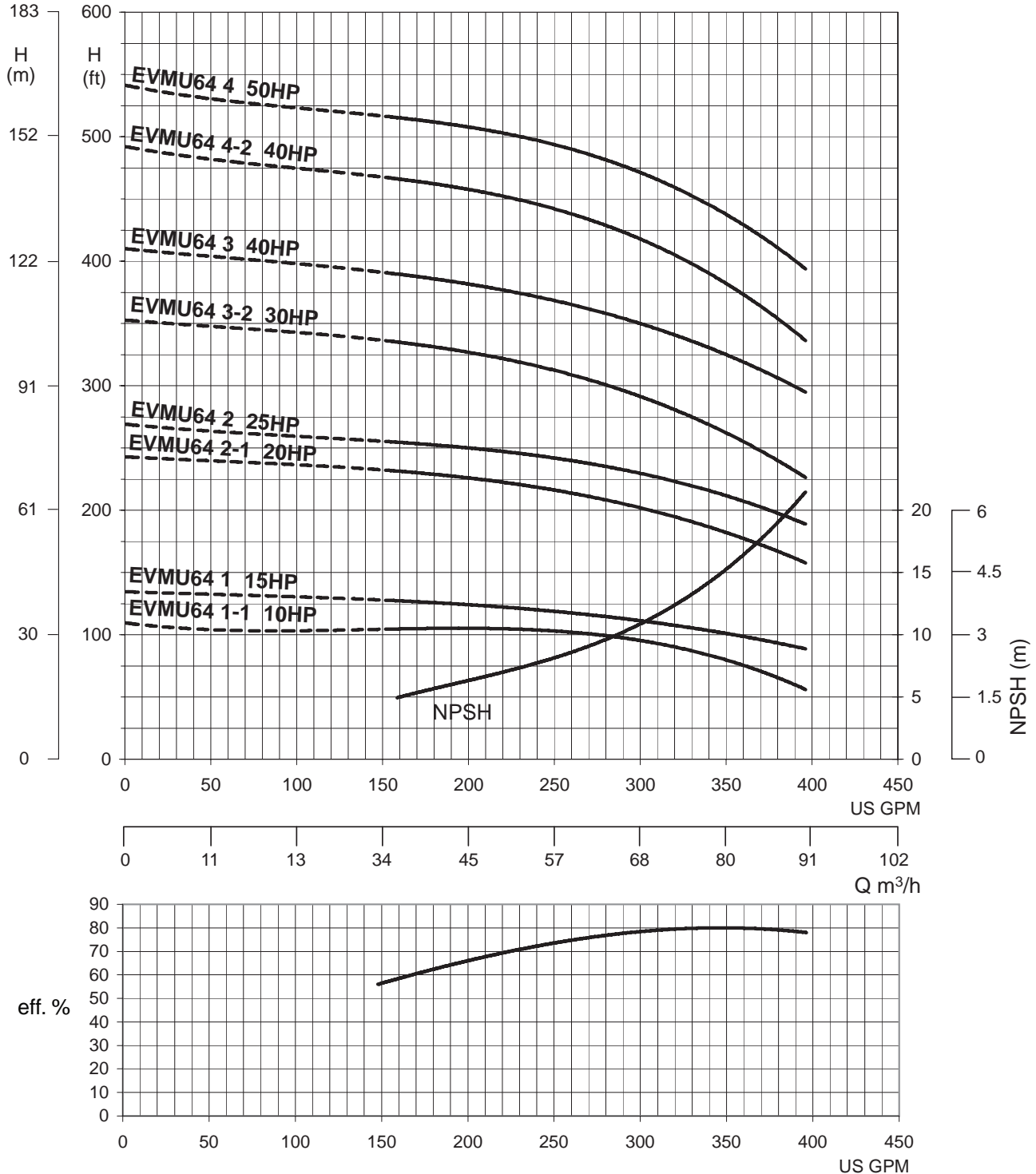

Water Temperature: 20° C (68° F)

SHAFT SEAL

EVMSU(L)1-3-5-10-15-20

1. Shaft Seal

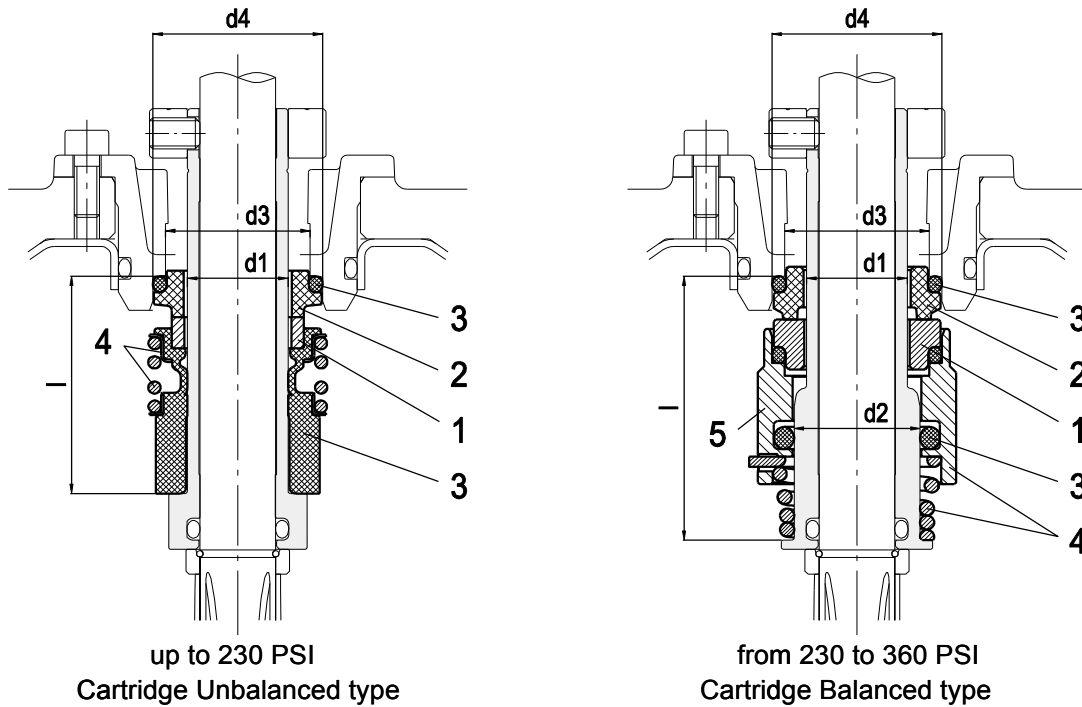

2. Type of Shaft Seal and Dimensions [in]

Pump model	Operating temperature range	Shaft seal type		Shaft seal material					Type key
		Unbalanced	Balanced	1 Rotating Part	2 Stationary Part	3 Elastomers	4 Compression spring	5 Collar	
230 PSI	- 22°F to + 248°F	○		SiC	Carbon	EPDM	AISI 316		E
	- 22°F to + 248°F	●		SiC	Carbon	FPM	AISI 316		S
	- 22°F to + 248°F*		○	SiC with graphite	SiC	EPDM	AISI 316		R
	- 22°F to + 248°F*		○	SiC with graphite	SiC	FPM	AISI 316		G
	- 22°F to + 248°F		○	SiC	Carbon	EPDM	AISI 316		B
360 PSI	- 22°F to + 248°F		○	SiC	Carbon	EPDM	AISI 316		E
	- 22°F to + 248°F		●	SiC	Carbon	FPM	AISI 316		S
	- 22°F to + 248°F*		○	SiC with graphite	SiC	EPDM	AISI 316		R
	- 22°F to + 248°F*		○	SiC with graphite	SiC	FPM	AISI 316		G

*Operation above 248°F is possible under certain conditions. Consult factory for details.

NOTE: Refer to selection tables on pages 9 and 10 for working pressure by model.

Legend: ● Standard ○ Options

Pump model	Shaft seal type	Max operating pressure	d1 [in]	d2 [in]	d3 [in]	d4 [in]	l [in]
EVMSU(L) 1/3/5	Cartridge	Unbalanced	0.630	-	0.906	1.063	1.378
		Balanced		0.787			1.673
EVMSU(L) 10/15/20	Cartridge	Unbalanced	0.787	-	1.142	1.378	1.476
		Balanced		0.945			1.772

Dimensions conform to standard EN12756

MECHANICAL SEAL

EVMUG 32, 45, 64

EVMUL 32, 45, 64

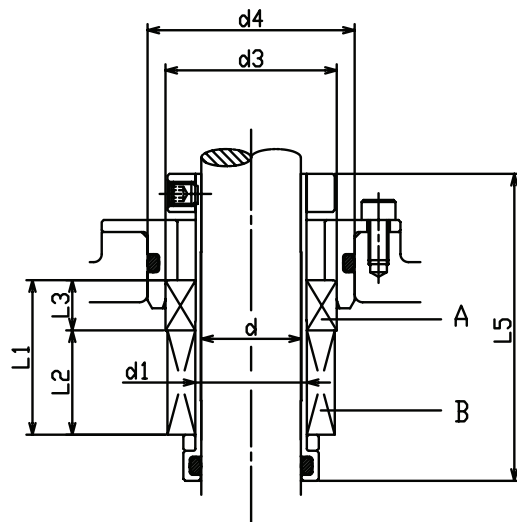

working pressure to 370 PSI
Standard Seal

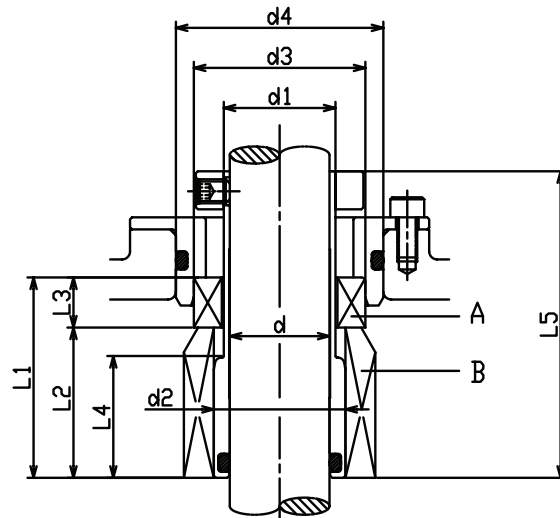

working pressure to 440 PSI
Standard Seal

Size (inch)	Max. working pressure (psi)	d (inch)	d1 (inch)	d2 (inch)	d3 (inch)	d4 (inch)	L1 (inch)	L2 (inch)	L3 (inch)	L4 (inch)	L5 (inch)	Material							
												A stationary seal ring	B rotary seal ring	elastomer	spring				
1.102	232	0.984	1.102	-	1.693	2.047	1.535	1.043	0.492	-	2.894	Carbon graphite	Silicon Carbide	FPM	316 Ti				
	370			1.299												1.969	1.516	0.453	1.181
	440																		

Maximum Working Pressure

Model	Maximum Working Pressure
EVMU32 1 - EVMU32 4-3	232 PSI
EVMU45 1-1 - EVMU45 3	
EVMU64 1-1 - EVMU64 3	
EVMU32 5 - EVMU32 8-3	370 PSI
EVMU45 4-1 - EVMU45 7-2	
EVMU64 4-2 - EVMU64 4	
EVMU32 9 - EVMU32 10-1	440 PSI

TECHNICAL DATA

EVMSU(L)1

DIMENSIONS

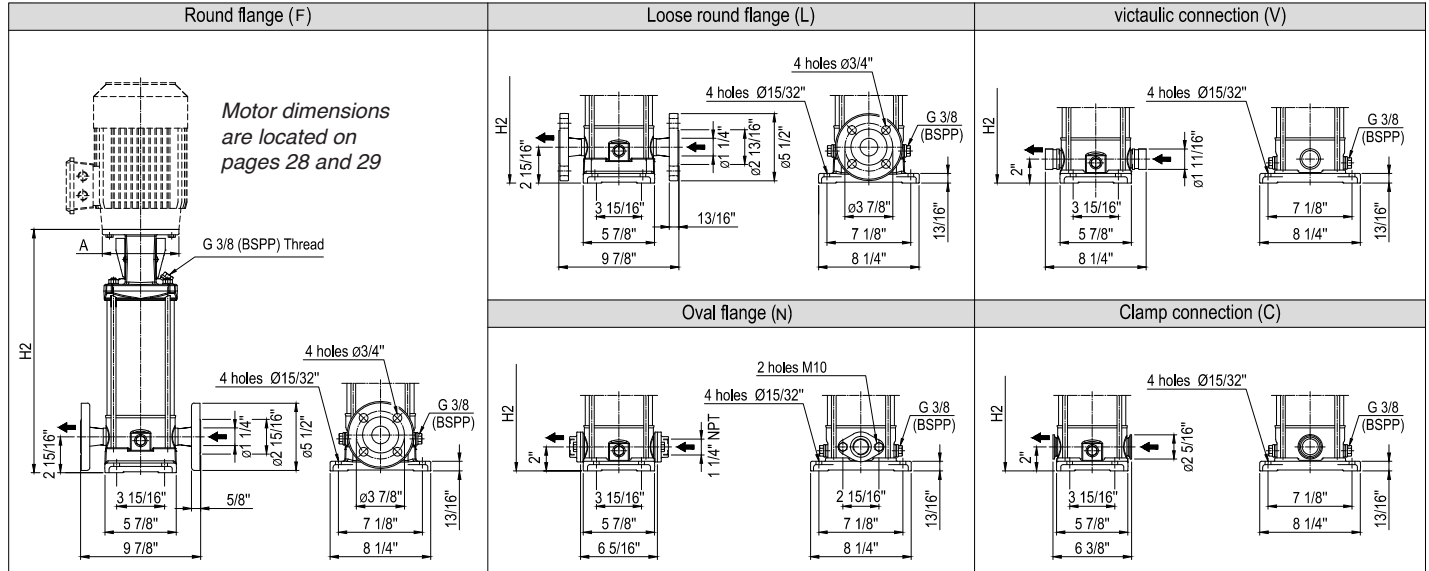

EVMSU(L)1	Pump Model	Pmax [PSI]	Motor Frame						Round flange (F) Loose round flange (L)				Oval flange (N)				Victaulic connection (V) Clamp connection (C)			
			TEFC			ODP			TEFC		ODP		TEFC		ODP		TEFC		ODP	
			HP	NEMA Frame	A	HP	NEMA Frame	A	H2	Pump Weight	H2	Pump Weight	H2	Pump Weight	H2	Pump Weight	H2	Pump Weight	H2	Pump Weight
EVMSU(L)1-2	230	0.5	56C	6 5/8"	0.5	56C	6 5/8"	11 7/8"	25.1 lb	11 7/8"	25.1 lb	10 7/8"	23.6 lb	10 7/8"	23.6 lb	10 7/8"	23.6 lb	11 7/8"	23.6 lb	
EVMSU(L)1-3	230	0.5	56C	6 5/8"	0.5	56C	6 5/8"	12 11/16"	26.2 lb	12 11/16"	26.2 lb	11 3/4"	24.7 lb	11 3/4"	24.7 lb	11 3/4"	24.4 lb	12 11/16"	24.4 lb	
EVMSU(L)1-4	230	0.5	56C	6 5/8"	0.5	56C	6 5/8"	13 9/16"	27.1 lb	13 9/16"	27.1 lb	12 9/16"	25.5 lb	12 9/16"	25.5 lb	12 9/16"	25.3 lb	13 9/16"	25.3 lb	
EVMSU(L)1-5	230	0.5	56C	6 5/8"	0.5	56C	6 5/8"	14 3/8"	28.0 lb	14 3/8"	28.0 lb	13 3/8"	26.7 lb	13 3/8"	26.7 lb	13 3/8"	26.4 lb	14 3/8"	26.4 lb	
EVMSU(L)1-6	230	0.75	56C	6 5/8"	0.75	56C	6 5/8"	15 3/16"	28.9 lb	15 3/16"	28.9 lb	14 3/16"	27.5 lb	14 3/16"	27.5 lb	14 3/16"	27.3 lb	15 3/16"	27.3 lb	
EVMSU(L)1-7	230	0.75	56C	6 5/8"	0.75	56C	6 5/8"	16"	30.0 lb	15 5/8"	30.0 lb	15"	28.7 lb	14 5/8"	28.7 lb	15"	28.5 lb	15 5/8"	28.5 lb	
EVMSU(L)1-8	230	1	56C	6 5/8"	1	56C	6 5/8"	16 13/16"	31.2 lb	16 7/8"	31.2 lb	15 7/8"	29.6 lb	15 7/8"	29.6 lb	15 7/8"	29.4 lb	16 7/8"	29.4 lb	
EVMSU(L)1-9	230	1	56C	6 5/8"	1	56C	6 5/8"	17 11/16"	32.0 lb	17 11/16"	32.0 lb	16 11/16"	30.5 lb	16 11/16"	30.5 lb	16 11/16"	30.5 lb	17 11/16"	30.5 lb	
EVMSU(L)1-10	230	1	56C	6 5/8"	1	56C	6 5/8"	18 1/2"	32.9 lb	18 1/2"	32.9 lb	17 1/2"	31.6 lb	17 1/2"	31.6 lb	17 1/2"	31.4 lb	18 1/2"	31.4 lb	
EVMSU(L)1-11	230	1.5	56C	6 5/8"	1.5	56C	6 5/8"	19 5/16"	34.0 lb	19 5/16"	34.0 lb	18 5/16"	32.5 lb	18 5/16"	32.5 lb	18 5/16"	32.3 lb	19 5/16"	32.3 lb	
EVMSU(L)1-12	230	1.5	56C	6 5/8"	1.5	56C	6 5/8"	20 1/8"	34.9 lb	20 1/8"	34.9 lb	19 3/16"	33.4 lb	19 3/16"	33.4 lb	19 3/16"	33.4 lb	20 1/8"	33.4 lb	
EVMSU(L)1-13	230	1.5	56C	6 5/8"	1.5	56C	6 5/8"	21"	36.4 lb	21"	36.4 lb	20"	34.9 lb	20"	34.9 lb	20"	34.9 lb	21"	34.9 lb	
EVMSU(L)1-14	230	1.5	56C	6 5/8"	1.5	56C	6 5/8"	21 13/16"	37.3 lb	21 13/16"	37.3 lb	20 13/16"	35.8 lb	20 13/16"	35.8 lb	20 13/16"	35.8 lb	21 13/16"	35.8 lb	
EVMSU(L)1-16	230	2	56C	6 5/8"	2	56C	6 5/8"	23 7/16"	39.2 lb	23 7/16"	39.2 lb	22 7/16"	37.7 lb	22 1/2"	37.7 lb	22 7/16"	37.7 lb	23 7/16"	37.7 lb	
EVMSU(L)1-18	230	2	56C	6 5/8"	2	56C	6 5/8"	25 1/8"	41.2 lb	25 1/8"	41.2 lb	24 1/8"	39.7 lb	24 1/8"	39.7 lb	24 1/8"	39.7 lb	25 1/8"	39.7 lb	
EVMSU(L)1-20	360	2	56C	6 5/8"	2	56C	6 5/8"	26 3/4"	43.2 lb	26 3/4"	43.2 lb	-	-	25 3/4"	41.7 lb	25 3/4"	41.7 lb	26 3/4"	41.7 lb	
EVMSU(L)1-22	360	3	182TC	9 1/16"	3	145TC	6 5/8"	31 15/16"	51.9 lb	24 15/16"	34.5 lb	-	-	30 15/16"	50.4 lb	24 15/16"	32.9 lb	-	-	
EVMSU(L)1-24	360	3	182TC	9 1/16"	3	145TC	6 5/8"	33 9/16"	54.1 lb	26 9/16"	36.7 lb	-	-	32 9/16"	52.6 lb	26 9/16"	35.2 lb	-	-	
EVMSU(L)1-26	360	3	182TC	9 1/16"	3	145TC	6 5/8"	35 1/4"	56.1 lb	28 1/4"	38.7 lb	-	-	34 1/4"	54.5 lb	28 1/4"	37.1 lb	-	-	
EVMSU(L)1-27	360	3	182TC	9 1/16"	3	145TC	6 5/8"	36 1/16"	57.2 lb	29 1/16"	39.8 lb	-	-	35 1/16"	55.6 lb	29 1/16"	38.2 lb	-	-	
EVMSU(L)1-29	360	3	182TC	9 1/16"	3	145TC	6 5/8"	37 11/16"	59.2 lb	30 11/16"	41.8 lb	-	-	36 3/4"	57.6 lb	30 11/16"	40.2 lb	-	-	

Requires 145TC motor bracket

TECHNICAL DATA

EVMSU(L)3

DIMENSIONS

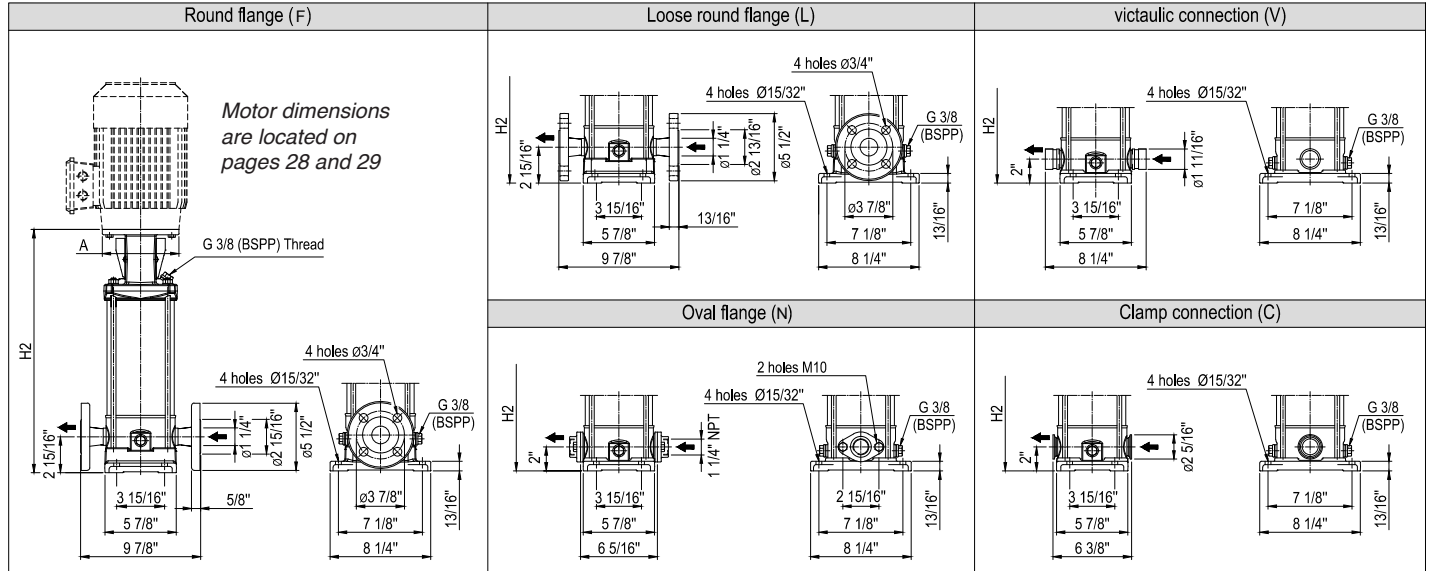

EVMSU(L)3	Pump Model	Pmax [PSI]	Motor Frame						Round flange (F) Loose round flange (L)				Oval flange (N)				Victaulic connection (V) Clamp connection (C)			
			TEFC			ODP			TEFC		ODP		TEFC		ODP		TEFC		ODP	
			HP	NEMA Frame	A	HP	NEMA Frame	A	H2	Pump Weight	H2	Pump Weight	H2	Pump Weight	H2	Pump Weight	H2	Pump Weight	H2	Pump Weight
EVMSU(L)3-2	230	0.5	56C	6 5/8"	0.5	56C	6 5/8"	11 7/8"	24.9 lb	11 7/8"	24.9 lb	10 7/8"	23.3 lb	10 7/8"	23.3 lb	10 7/8"	23.1 lb	11 7/8"	23.1 lb	
EVMSU(L)3-3	230	0.75	56C	6 5/8"	0.75	56C	6 5/8"	12 11/16"	25.8 lb	12 11/16"	25.8 lb	11 3/4"	24.2 lb	11 3/4"	24.2 lb	11 3/4"	24.2 lb	12 11/16"	24.2 lb	
EVMSU(L)3-4	230	1	56C	6 5/8"	1	56C	6 5/8"	13 9/16"	26.7 lb	13 9/16"	26.7 lb	12 9/16"	25.4 lb	12 9/16"	25.4 lb	12 9/16"	25.2 lb	13 9/16"	25.2 lb	
EVMSU(L)3-5	230	1	56C	6 5/8"	1	56C	6 5/8"	14 3/8"	27.8 lb	14 3/8"	27.8 lb	13 3/8"	26.3 lb	13 3/8"	26.3 lb	13 3/8"	26.1 lb	14 3/8"	26.1 lb	
EVMSU(L)3-6	230	1.5	56C	6 5/8"	1.5	56C	6 5/8"	15 3/16"	28.7 lb	15 3/16"	28.7 lb	14 3/16"	27.2 lb	14 3/16"	27.2 lb	14 3/16"	27.0 lb	15 3/16"	27.0 lb	
EVMSU(L)3-7	230	1.5	56C	6 5/8"	1.5	56C	6 5/8"	16"	29.6 lb	16"	29.6 lb	15"	28.1 lb	15 1/16"	28.1 lb	15"	28.1 lb	16"	28.1 lb	
EVMSU(L)3-8	230	2	56C	6 5/8"	2	56C	6 5/8"	16 13/16"	30.2 lb	16 7/8"	30.2 lb	15 7/8"	28.9 lb	15 7/8"	28.9 lb	15 7/8"	28.6 lb	16 7/8"	28.6 lb	
EVMSU(L)3-9	230	2	56C	6 5/8"	2	56C	6 5/8"	17 11/16"	31.1 lb	17 11/16"	31.1 lb	16 11/16"	29.7 lb	16 11/16"	29.7 lb	16 11/16"	29.5 lb	17 11/16"	29.5 lb	
EVMSU(L)3-10	230	2	56C	6 5/8"	2	56C	6 5/8"	18 1/2"	32.2 lb	18 1/2"	32.2 lb	17 1/2"	30.6 lb	17 1/2"	30.6 lb	17 1/2"	30.4 lb	18 1/2"	30.4 lb	
EVMSU(L)3-11	230	3	182TC	9 1/16"	3	145TC	6 5/8"	22 13/16"	38.7 lb	15 13/16"	21.3 lb	21 13/16"	37.1 lb	14 13/16"	19.7 lb	21 13/16"	36.9 lb	15 13/16"	19.5 lb	
EVMSU(L)3-12	230	3	182TC	9 1/16"	3	145TC	6 5/8"	23 5/8"	39.3 lb	16 5/8"	21.9 lb	22 11/16"	38.0 lb	15 11/16"	20.6 lb	22 11/16"	37.8 lb	16 5/8"	20.4 lb	
EVMSU(L)3-13	230	3	182TC	9 1/16"	3	145TC	6 5/8"	24 1/2"	41.1 lb	17 1/2"	23.7 lb	23 1/2"	39.6 lb	16 1/2"	22.1 lb	23 1/2"	39.6 lb	17 1/2"	22.1 lb	
EVMSU(L)3-14	230	3	182TC	9 1/16"	3	145TC	6 5/8"	25 5/16"	42.0 lb	18 5/16"	24.6 lb	24 5/16"	40.4 lb	17 5/16"	23.0 lb	24 5/16"	40.4 lb	18 5/16"	23.0 lb	
EVMSU(L)3-15	230	3	182TC	9 1/16"	Consult Factory			26 1/8"	42.5 lb	Consult Factory		25 1/8"	41.2 lb	Consult Factory		25 1/8"	40.9 lb	Consult Factory		
EVMSU(L)3-16	360	5	184TC	9 1/16"	5	182TC	9 1/16"	26 15/16"	44.7 lb	26 5/8"	44.7 lb	-	-	-	-	26"	43.1 lb	26 5/8"	43.1 lb	
EVMSU(L)3-17	360	5	184TC	9 1/16"	5	182TC	9 1/16"	27 13/16"	45.8 lb	27 7/16"	45.8 lb	-	-	-	-	26 13/16"	44.0 lb	27 7/16"	44.0 lb	
EVMSU(L)3-19	360	5	184TC	9 1/16"	5	182TC	9 1/16"	29 7/16"	47.8 lb	29 1/16"	47.8 lb	-	-	-	-	28 7/16"	46.0 lb	29 1/16"	46.0 lb	
EVMSU(L)3-20	360	5	184TC	9 1/16"	5	182TC	9 1/16"	30 1/4"	48.7 lb	29 15/16"	48.7 lb	-	-	-	-	29 1/4"	47.1 lb	29 15/16"	47.1 lb	
EVMSU(L)3-21	360	5	184TC	9 1/16"	5	182TC	9 1/16"	31 1/16"	49.8 lb	30 3/4"	49.8 lb	-	-	-	-	30 1/8"	48.0 lb	30 3/4"	48.0 lb	
EVMSU(L)3-22	360	5	184TC	9 1/16"	5	182TC	9 1/16"	31 15/16"	50.6 lb	31 9/16"	50.6 lb	-	-	-	-	30 15/16"	49.1 lb	31 9/16"	49.1 lb	
EVMSU(L)3-23	360	5	184TC	9 1/16"	5	182TC	9 1/16"	32 3/4"	51.7 lb	32 3/8"	51.7 lb	-	-	-	-	31 3/4"	50.0 lb	32 3/8"	50.0 lb	

Requires 145TC motor bracket

TECHNICAL DATA

EVMSU(L)5

DIMENSIONS

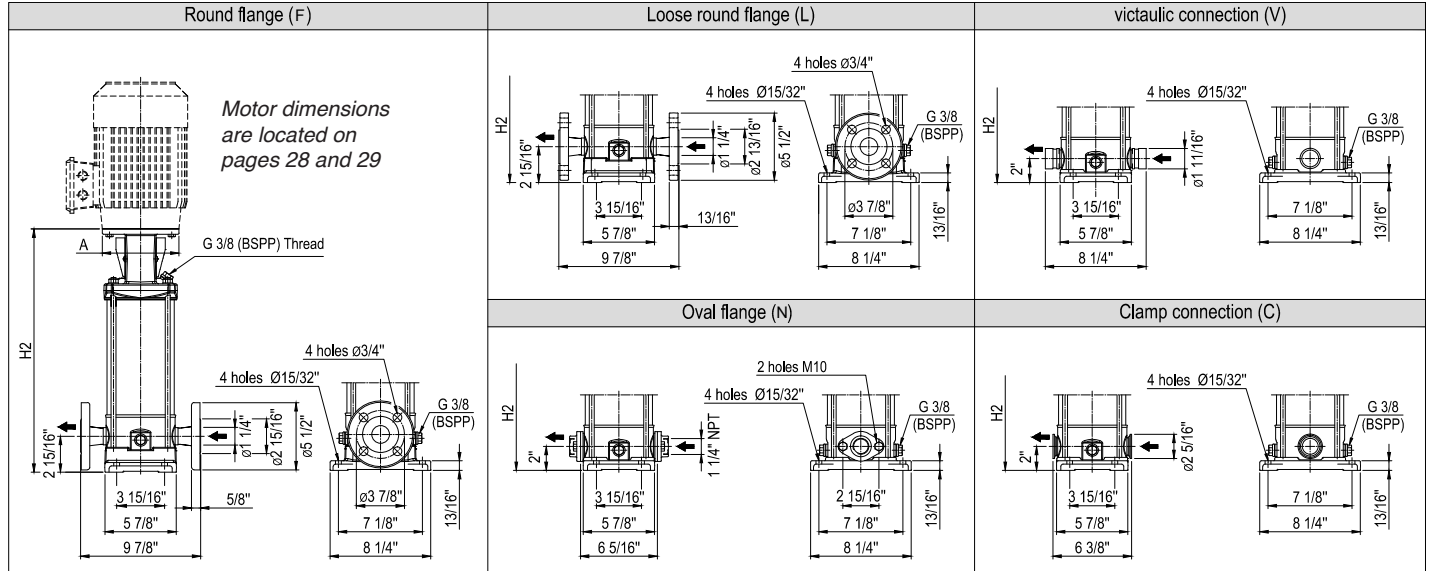

EVMSU(L)5 Pump Model	Pmax [PSI]	Motor Frame						Round flange (F) Loose round flange (L)				Oval flange (N)				Victaulic connection (V) Clamp connection (C)			
		TEFC			ODP			TEFC		ODP		TEFC		ODP		TEFC		ODP	
		HP	NEMA Frame	A	HP	NEMA Frame	A	H2	Pump Weight	H2	Pump Weight	H2	Pump Weight	H2	Pump Weight	H2	Pump Weight	H2	Pump Weight
EVMSU(L)5-2	230	1	56C	6 5/8"	1	56C	6 5/8"	12 7/16"	25.0 lb	12 7/16"	25.0 lb	11 7/16"	22.8 lb	11 7/16"	22.8 lb	11 7/16"	22.6 lb	12 7/16"	22.6 lb
EVMSU(L)5-3	230	1.5	56C	6 5/8"	1.5	56C	6 5/8"	13 9/16"	26.1 lb	13 9/16"	26.1 lb	12 9/16"	23.7 lb	12 9/16"	23.7 lb	12 9/16"	23.7 lb	13 9/16"	23.7 lb
EVMSU(L)5-4	230	2	56C	6 5/8"	2	56C	6 5/8"	14 5/8"	27.3 lb	14 5/8"	27.3 lb	13 5/8"	25.1 lb	13 11/16"	25.1 lb	13 5/8"	24.9 lb	14 5/8"	24.9 lb
EVMSU(L)5-5	230	3	182TC	9 1/16"	3	145TC	6 5/8"	19 1/4"	34.0 lb	12 1/4"	16.6 lb	18 1/4"	31.6 lb	11 1/4"	14.2 lb	18 1/4"	31.6 lb	12 1/4"	14.2 lb
EVMSU(L)5-6	230	3	182TC	9 1/16"	3	145TC	6 5/8"	20 5/16"	34.9 lb	13 3/8"	17.5 lb	19 3/8"	32.7 lb	12 3/8"	15.3 lb	19 3/8"	32.5 lb	13 3/8"	15.1 lb
EVMSU(L)5-7	230	5	184TC	9 1/16"	5	182TC	9 1/16"	21 7/16"	36.1 lb	21 1/8"	36.1 lb	20 7/16"	33.9 lb	20 1/8"	33.9 lb	20 7/16"	33.7 lb	21 1/8"	33.7 lb
EVMSU(L)5-8	230	5	184TC	9 1/16"	5	182TC	9 1/16"	22 9/16"	36.8 lb	22 3/16"	36.8 lb	21 9/16"	34.6 lb	21 3/16"	34.6 lb	21 9/16"	34.3 lb	22 3/16"	34.3 lb
EVMSU(L)5-9	230	5	184TC	9 1/16"	5	182TC	9 1/16"	23 5/8"	37.9 lb	23 1/3"	37.9 lb	22 11/16"	35.4 lb	22 5/16"	35.4 lb	22 11/16"	35.4 lb	23 5/16"	35.4 lb
EVMSU(L)5-10	230	5	184TC	9 1/16"	5	182TC	9 1/16"	24 3/4"	39.0 lb	24 3/8"	39.0 lb	23 3/4"	36.5 lb	23 7/16"	36.5 lb	23 3/4"	36.5 lb	24 3/8"	36.5 lb
EVMSU(L)5-11	230	5	184TC	9 1/16"	5	182TC	9 1/16"	25 7/8"	40.5 lb	25 1/2"	40.5 lb	24 7/8"	38.3 lb	24 1/2"	38.3 lb	24 7/8"	38.1 lb	25 1/2"	38.1 lb
EVMSU(L)5-12	230	7.5	213TC	9 1/16"	-	-	-	27 9/16"	51.8 lb	-	-	-	-	-	-	26 5/8"	49.4 lb	-	-
EVMSU(L)5-13	360	7.5	213TC	9 1/16"	-	-	-	28 11/16"	56.1 lb	-	-	-	-	-	-	27 11/16"	53.6 lb	-	-
EVMSU(L)5-14	360	7.5	213TC	9 1/16"	-	-	-	29 13/16"	57.2 lb	-	-	-	-	-	-	28 13/16"	54.7 lb	-	-
EVMSU(L)5-15	360	7.5	213TC	9 1/16"	-	-	-	30 7/8"	58.3 lb	-	-	-	-	-	-	29 15/16"	55.8 lb	-	-
EVMSU(L)5-16	360	7.5	213TC	9 1/16"	-	-	-	32"	59.6 lb	-	-	-	-	-	-	31"	57.2 lb	-	-
EVMSU(L)5-17	360	7.5	213TC	9 1/16"	-	-	-	33 1/8"	60.9 lb	-	-	-	-	-	-	32 1/8"	58.5 lb	-	-
EVMSU(L)5-19	360	10	215TC	9 1/16"	-	-	-	35 5/16"	62.9 lb	-	-	-	-	-	-	34 5/16"	60.5 lb	-	-

Requires 145TC motor bracket

TECHNICAL DATA

EVMSU(L)10

DIMENSIONS

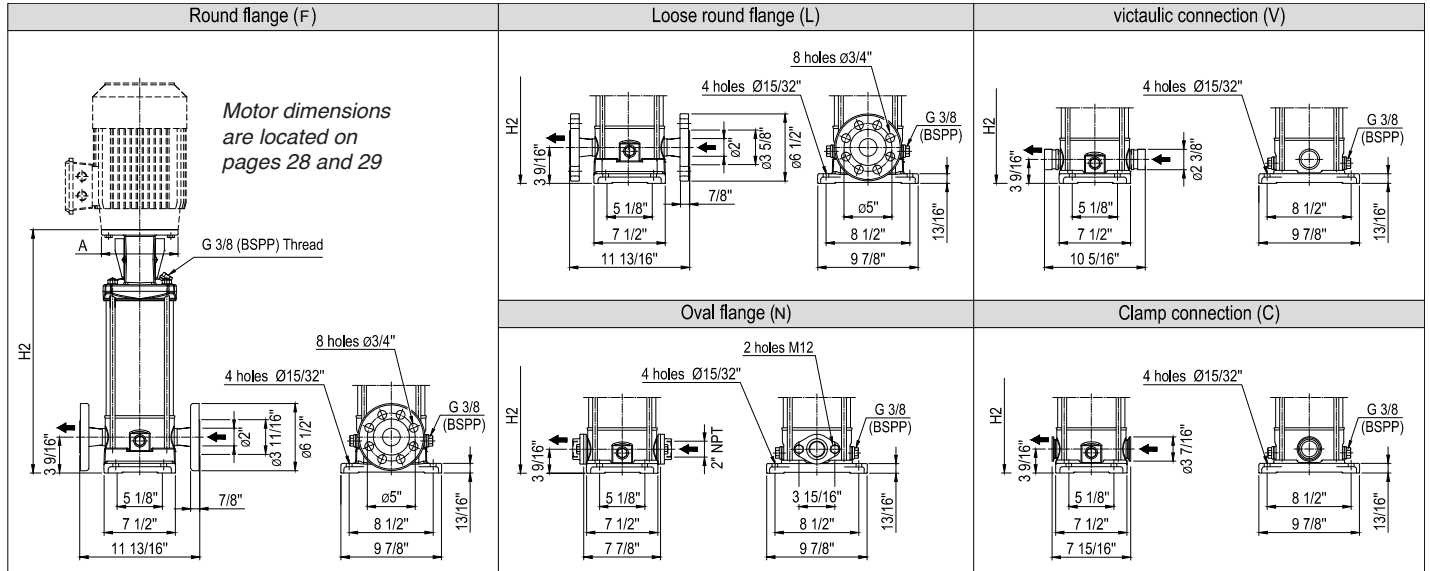

EVMSU(L)10	Pump Model	Pmax [PSI]	Motor Frame						Round flange (F) Loose round flange (L)				Oval flange (N)				Victaulic connection (V) Clamp connection (C)			
			TEFC			ODP			TEFC		ODP		TEFC		ODP		TEFC		ODP	
			HP	NEMA Frame	A	HP	NEMA Frame	A	H2	Pump Weight	H2	Pump Weight	H2	Pump Weight	H2	Pump Weight	H2	Pump Weight	H2	Pump Weight
EVMSU(L)10-1	230	1	56C	6 5/8"	1	56C	6 5/8"	14 3/8"	45.5 lb	14"	45.5 lb	14"	43.3 lb	14"	43.3 lb	14"	43.1 lb	14"	43.1 lb	
EVMSU(L)10-2	230	2	56C	6 5/8"	2	56C	6 5/8"	14 3/8"	46.3 lb	14"	46.3 lb	14"	43.9 lb	14"	43.9 lb	14"	43.9 lb	14"	43.9 lb	
EVMSU(L)10-3	230	3	182TC	9 1/16"	3	145TC	6 5/8"	19 15/16"	57.4 lb	10 15/16"	32.9 lb	19 1/2"	55.2 lb	10 15/16"	30.6 lb	19 1/2"	55.2 lb	10 15/16"	30.6 lb	
EVMSU(L)10-4	230	5	184TC	9 1/16"	5	182TC	9 1/16"	21 1/16"	59.4 lb	20 11/16"	59.4 lb	20 11/16"	57.2 lb	20 11/16"	57.2 lb	20 11/16"	57.0 lb	20 11/16"	57.0 lb	
EVMSU(L)10-5	230	5	184TC	9 1/16"	5	182TC	9 1/16"	22 1/4"	61.2 lb	21 7/8"	61.2 lb	21 7/8"	59.0 lb	21 7/8"	59.0 lb	21 7/8"	59.0 lb	21 7/8"	59.0 lb	
EVMSU(L)10-6	230	5	184TC	9 1/16"	5	182TC	9 1/16"	23 7/16"	63.2 lb	23 1/16"	63.2 lb	23 1/16"	60.7 lb	23 1/16"	60.7 lb	23 1/16"	60.7 lb	23 1/16"	60.7 lb	
EVMSU(L)10-7	230	7.5	184TC	9 1/16"	7.5	184TC	9 1/16"	24 5/8"	68.0 lb	24 1/4"	68.0 lb	24 1/4"	65.6 lb	24 1/4"	65.6 lb	24 1/4"	65.6 lb	24 1/4"	65.6 lb	
EVMSU(L)10-8	230	7.5	184TC	9 1/16"	7.5	184TC	9 1/16"	25 13/16"	70.7 lb	25 7/16"	70.7 lb	25 7/16"	68.3 lb	25 7/16"	68.3 lb	25 7/16"	68.3 lb	25 7/16"	68.3 lb	
EVMSU(L)10-9	230	7.5	184TC	9 1/16"	7.5	184TC	9 1/16"	27"	72.4 lb	27"	72.4 lb	26 5/8"	70.2 lb	26 5/8"	70.2 lb	26 5/8"	70.0 lb	26 5/8"	70.0 lb	
EVMSU(L)10-10	230	10	215TC	9 1/16"	10	213TC	9 1/16"	28 3/16"	75.2 lb	27 13/16"	75.2 lb	27 13/16"	73.0 lb	27 13/16"	73.0 lb	27 13/16"	73.0 lb	27 13/16"	73.0 lb	
EVMSU(L)10-11	360	10	215TC	9 1/16"	10	213TC	9 1/16"	29 3/8"	78.9 lb	29"	78.9 lb	-	-	-	-	28 15/16"	76.5 lb	29"	76.5 lb	
EVMSU(L)10-12	360	10	215TC	9 1/16"	10	213TC	9 1/16"	30 9/16"	80.9 lb	30 3/16"	80.9 lb	-	-	-	-	30 1/8"	78.5 lb	30 3/16"	78.5 lb	
EVMSU(L)10-14	360	15	215TC	9 1/16"	15	215TC	9 1/16"	32 7/8"	90.8 lb	32 1/2"	90.8 lb	-	-	-	-	32 1/2"	88.4 lb	32 1/2"	88.4 lb	
EVMSU(L)10-15	360	15	215TC	9 1/16"	15	215TC	9 1/16"	34 1/16"	92.8 lb	33 11/16"	92.8 lb	-	-	-	-	33 11/16"	90.6 lb	33 11/16"	90.6 lb	
EVMSU(L)10-16	360	15	215TC	9 1/16"	15	215TC	9 1/16"	35 1/4"	94.8 lb	34 7/8"	94.8 lb	-	-	-	-	34 7/8"	92.6 lb	34 7/8"	92.6 lb	

Requires 145TC motor bracket

TECHNICAL DATA

EVMSU(L)15

DIMENSIONS

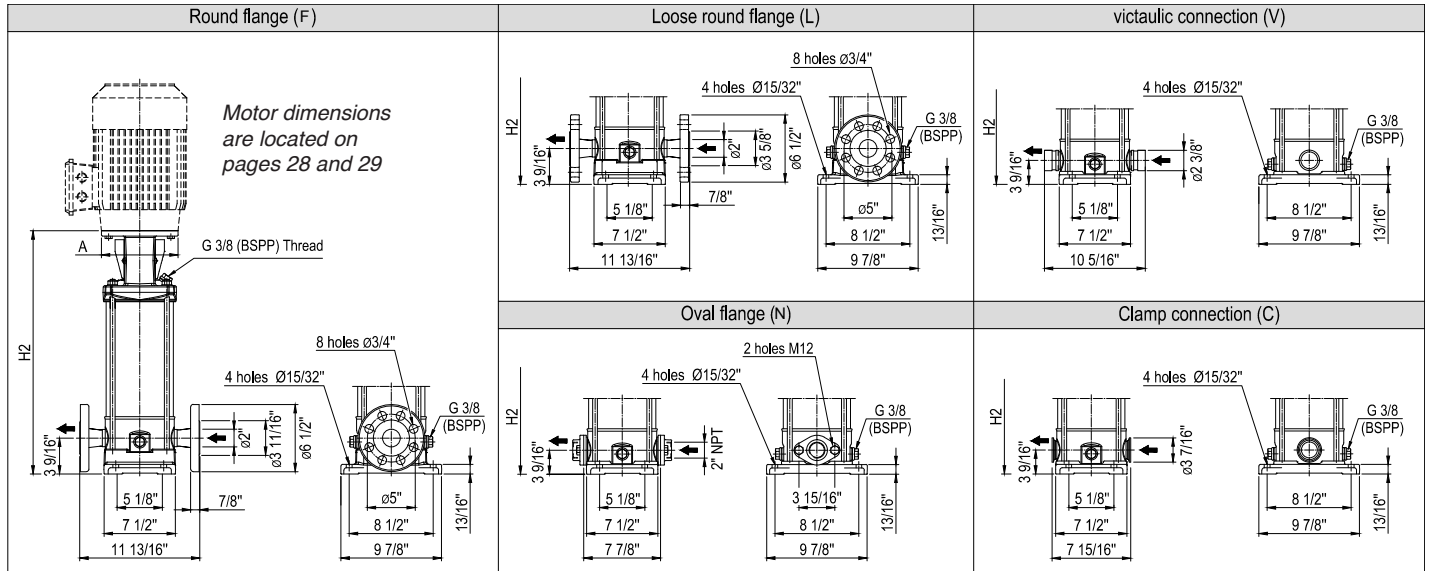

EVMSU(L)15	Pump Model	P _{max} [PSI]	Motor Frame						Round flange (F) Loose round flange (L)				Oval flange (N)				Victaulic connection (V) Clamp connection (C)			
			TEFC			ODP			TEFC		ODP		TEFC		ODP		TEFC		ODP	
			HP	NEMA Frame	A	HP	NEMA Frame	A	H2	Pump Weight	H2	Pump Weight	H2	Pump Weight	H2	Pump Weight	H2	Pump Weight	H2	Pump Weight
EVMSU(L)15-1	230	2	56C	6 5/8"	2	56C	6 5/8"	15 5/16"	41.7 lb	15 5/16"	41.7 lb	15 5/16"	37.5 lb	15 5/16"	37.5 lb	15 5/16"	37.5 lb	15 5/16"	37.5 lb	
EVMSU(L)15-2	230	5	184TC	9 1/16"	5	182TC	9 1/16"	19 11/16"	51.5 lb	19 11/16"	51.5 lb	19 11/16"	47.5 lb	19 11/16"	47.5 lb	19 11/16"	47.3 lb	19 11/16"	47.3 lb	
EVMSU(L)15-3	230	7.5	184TC	9 1/16"	7.5	184TC	9 1/16"	21 1/4"	57.2 lb	21 1/4"	57.2 lb	21 1/4"	53.0 lb	21 1/4"	53.0 lb	21 1/4"	53.0 lb	21 1/4"	53.0 lb	
EVMSU(L)15-4	230	10	215TC	9 1/16"	10	213TC	9 1/16"	22 13/16"	60.8 lb	22 13/16"	60.8 lb	22 13/16"	56.6 lb	22 13/16"	56.6 lb	22 13/16"	56.6 lb	22 13/16"	56.6 lb	
EVMSU(L)15-5	230	10	215TC	9 1/16"	10	213TC	9 1/16"	24 3/8"	63.3 lb	24 3/8"	63.3 lb	24 3/8"	59.1 lb	24 3/8"	59.1 lb	24 3/8"	59.1 lb	24 3/8"	59.1 lb	
EVMSU(L)15-6	230	15	215TC	9 1/16"	15	215TC	9 1/16"	25 15/16"	72.8 lb	25 15/16"	72.8 lb	25 15/16"	68.8 lb	25 15/16"	68.8 lb	25 15/16"	68.8 lb	25 15/16"	68.8 lb	
EVMSU(L)15-7	230	15	215TC	9 1/16"	15	215TC	9 1/16"	27 1/2"	77.0 lb	27 1/2"	77.0 lb	27 1/2"	72.8 lb	27 1/2"	72.8 lb	27 1/2"	72.8 lb	27 1/2"	72.8 lb	
EVMSU(L)15-8	360	20	256TC	9 1/16"	20	254TC	9 1/16"	29 11/16"	86.9 lb	29 11/16"	86.9 lb	-	-	29 11/16"	82.7 lb	29 11/16"	82.7 lb	29 11/16"	82.7 lb	
EVMSU(L)15-9	360	20	256TC	9 1/16"	20	254TC	9 1/16"	31 1/4"	89.7 lb	31 1/4"	89.7 lb	-	-	31 1/4"	85.5 lb	31 1/4"	85.5 lb	31 1/4"	85.5 lb	
EVMSU(L)15-10	360	20	256TC	9 1/16"	20	254TC	9 1/16"	32 13/16"	92.6 lb	32 13/16"	92.6 lb	-	-	32 13/16"	88.4 lb	32 13/16"	88.4 lb	32 13/16"	88.4 lb	
EVMSU(L)15-11	360	25	284TSC	11"	-	-	-	33 11/16"	91.8 lb	-	-	-	-	33 11/16"	87.7 lb	-	-	-	-	
EVMSU(L)15-12	360	25	284TSC	11"	-	-	-	35 5/16"	94.7 lb	-	-	-	-	35 5/16"	90.5 lb	-	-	-	-	

TECHNICAL DATA

EVMSU(L)20

DIMENSIONS

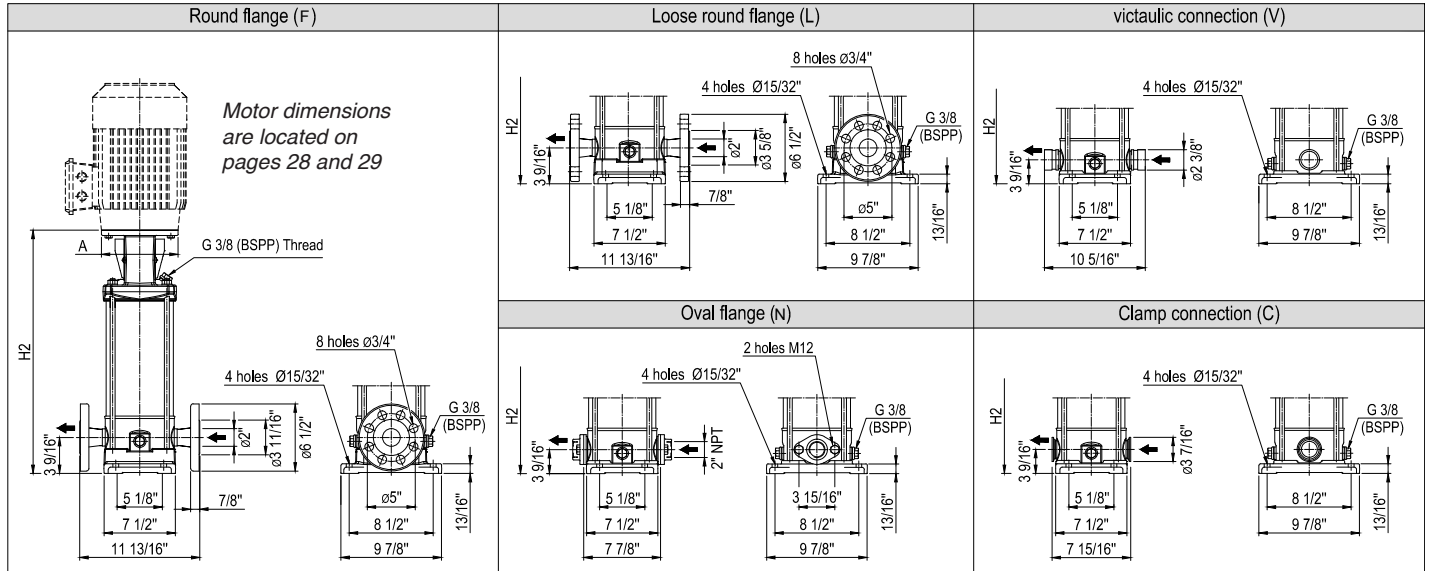

EVMSU(L)20	Pump Model	Pmax [PSI]	Motor Frame						Round flange (F) Loose round flange (L)				Oval flange (N)				Victaulic connection (V) Clamp connection (C)			
			TEFC			ODP			TEFC		ODP		TEFC		ODP		TEFC		ODP	
			HP	NEMA Frame	A	HP	NEMA Frame	A	H2	Pump Weight	H2	Pump Weight	H2	Pump Weight	H2	Pump Weight	H2	Pump Weight	H2	Pump Weight
EVMSU(L)20-1	230	3	182TC	8 1/2"	3	145TC	6 5/8"	19 11/16"	50.8 lb	11 1/16"	26.2 lb	19 11/16"	46.8 lb	11 1/16"	22.3 lb	19 11/16"	46.6 lb	11 1/16"	22.0 lb	
EVMSU(L)20-2	230	5	184TC	8 1/2"	5	182TC	9 1/16"	19 11/16"	51.5 lb	19 11/16"	51.5 lb	19 11/16"	47.5 lb	19 11/16"	47.5 lb	19 11/16"	47.3 lb	19 11/16"	47.3 lb	
EVMSU(L)20-3	230	7.5	184TC	8 1/2"	7.5	184TC	9 1/16"	21 1/4"	57.2 lb	21 1/4"	57.2 lb	21 1/4"	53.0 lb	21 1/4"	53.0 lb	21 1/4"	53.0 lb	21 1/4"	53.0 lb	
EVMSU(L)20-4	230	10	215TC	8 1/2"	10	213TC	8 1/2"	22 13/16"	60.8 lb	22 13/16"	60.8 lb	22 13/16"	56.9 lb	22 13/16"	56.9 lb	22 13/16"	56.6 lb	22 13/16"	56.6 lb	
EVMSU(L)20-5	230	15	215TC	8 1/2"	15	215TC	8 1/2"	24 3/8"	69.5 lb	24 3/8"	69.5 lb	24 3/8"	65.5 lb	24 3/8"	65.5 lb	24 3/8"	65.3 lb	24 3/8"	65.3 lb	
EVMSU(L)20-6	230	15	215TC	8 1/2"	15	215TC	8 1/2"	25 15/16"	70.1 lb	25 15/16"	70.1 lb	25 15/16"	65.9 lb	25 15/16"	65.9 lb	25 15/16"	65.9 lb	25 15/16"	65.9 lb	
EVMSU(L)20-7	360	20	256TC	9 1/16"	20	254TC	9 1/16"	28 1/8"	83.5 lb	28 1/8"	83.5 lb	-	-	-	-	28 1/8"	79.4 lb	28 1/8"	79.4 lb	
EVMSU(L)20-8	360	20	256TC	9 1/16"	20	254TC	9 1/16"	29 11/16"	86.4 lb	29 11/16"	86.4 lb	-	-	-	-	29 11/16"	82.2 lb	29 11/16"	82.2 lb	
EVMSU(L)20-9	360	25	284TSC	11"	-	-	-	30 9/16"	85.9 lb	-	-	-	-	-	-	30 9/16"	81.7 lb	-	-	
EVMSU(L)20-10	360	25	284TSC	11"	-	-	-	32 1/8"	88.8 lb	-	-	-	-	-	-	32 1/8"	84.6 lb	-	-	

Requires 145TC motor bracket

MOTOR DIMENSIONS

EVMSU(L)1-3

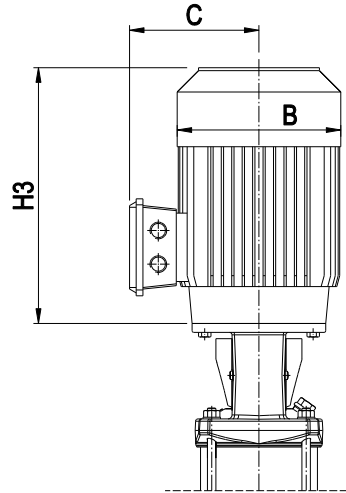

	Pump		TEFC motor			ODP motor				
	Pump Model	Horsepower	NEMA frame size	Dimensions [inches]			NEMA frame size	Dimensions [inches]		
				B	C	H3		B	C	H3
1	EVMSU(L)1-2	0.5	56C	6 1/4	5 1/4	11 7/16	56C	6 1/4	5 1/16	11 5/16
	EVMSU(L)1-3	0.5	56C	6 1/4	5 1/4	11 7/16	56C	6 1/4	5 1/16	11 5/16
	EVMSU(L)1-4	0.5	56C	6 1/4	5 1/4	11 7/16	56C	6 1/4	5 1/16	11 5/16
	EVMSU(L)1-5	0.5	56C	6 1/4	5 1/4	11 7/16	56C	6 1/4	5 1/16	11 5/16
	EVMSU(L)1-6	0.75	56C	6 1/4	5 1/4	11 7/16	56C	6 1/4	5 1/16	11 5/16
	EVMSU(L)1-7	0.75	56C	6 1/4	5 1/4	11 7/16	56C	6 1/4	5 1/16	11 5/16
	EVMSU(L)1-8	1	56C	7 1/4	5 1/4	13 5/8	56C	6 3/16	5 1/16	11 1/8
	EVMSU(L)1-9	1	56C	7 1/4	5 1/4	13 5/8	56C	6 3/16	5 1/16	11 1/8
	EVMSU(L)1-10	1	56C	7 1/4	5 1/4	13 5/8	56C	6 3/16	5 1/16	11 1/8
	EVMSU(L)1-11	1.5	56C	7 1/4	5 1/4	13 5/8	56C	7 1/4	5 5/8	13 9/16
	EVMSU(L)1-12	1.5	56C	7 1/4	5 1/4	13 5/8	56C	7 1/4	5 5/8	13 9/16
	EVMSU(L)1-13	1.5	56C	7 1/4	5 1/4	13 5/8	56C	7 1/4	5 5/8	13 9/16
	EVMSU(L)1-14	1.5	56C	7 1/4	5 1/4	13 5/8	56C	7 1/4	5 5/8	13 9/16
	EVMSU(L)1-16	2	56C	7 1/4	5 1/4	13 9/16	56C	6 1/4	5 1/16	11 5/16
	EVMSU(L)1-18	2	56C	7 1/4	5 1/4	13 9/16	56C	6 1/4	5 1/16	11 5/16
	EVMSU(L)1-20	2	56C	7 1/4	5 1/4	13 9/16	56C	6 1/4	5 1/16	11 5/16
	EVMSU(L)1-22	3	182TC	7 1/4	5 3/4	13 15/16	145TC	7 3/16	5 5/8	11 1/8
	EVMSU(L)1-24	3	182TC	7 1/4	5 3/4	13 15/16	145TC	7 3/16	5 5/8	11 1/8
	EVMSU(L)1-26	3	182TC	7 1/4	5 3/4	13 15/16	145TC	7 3/16	5 5/8	11 1/8
EVMSU(L)1-27	3	182TC	7 1/4	5 3/4	13 15/16	145TC	7 3/16	5 5/8	11 1/8	
EVMSU(L)1-29	3	182TC	7 1/4	5 3/4	13 15/16	145TC	7 3/16	5 5/8	11 1/8	
3	EVMSU(L)3-2	0.5	56C	6 1/4	5 1/4	11 7/16	56C	6 1/4	5 1/16	11 5/16
	EVMSU(L)3-3	0.75	56C	6 1/4	5 1/4	11 7/16	56C	6 1/4	5 1/16	11 5/16
	EVMSU(L)3-4	1	56C	7 1/4	5 1/4	13 5/8	56C	6 3/16	5 1/16	11 1/8
	EVMSU(L)3-5	1	56C	7 1/4	5 1/4	13 5/8	56C	6 3/16	5 1/16	11 1/8
	EVMSU(L)3-6	1.5	56C	7 1/4	5 1/4	13 5/8	56C	7 1/4	5 5/8	13 9/16
	EVMSU(L)3-7	1.5	56C	7 1/4	5 1/4	13 5/8	56C	7 1/4	5 5/8	13 9/16
	EVMSU(L)3-8	2	56C	7 1/4	5 1/4	13 9/16	56C	6 1/4	5 1/16	11 5/16
	EVMSU(L)3-9	2	56C	7 1/4	5 1/4	13 9/16	56C	6 1/4	5 1/16	11 5/16
	EVMSU(L)3-10	2	56C	7 1/4	5 1/4	13 9/16	56C	6 1/4	5 1/16	11 5/16
	EVMSU(L)3-11	3	182TC	7 1/4	5 3/4	13 15/16	145TC	7 3/16	5 5/8	11 1/8
	EVMSU(L)3-12	3	182TC	7 1/4	5 3/4	13 15/16	145TC	7 3/16	5 5/8	11 1/8
	EVMSU(L)3-13	3	182TC	7 1/4	5 3/4	13 15/16	145TC	7 3/16	5 5/8	11 1/8
	EVMSU(L)3-14	3	182TC	7 1/4	5 3/4	13 15/16	145TC	7 3/16	5 5/8	11 1/8
	EVMSU(L)3-15	3	182TC	7 1/4	5 3/4	13 15/16	Consult Factory			
	EVMSU(L)3-16	5	184TC	8 1/2	6 7/8	15 7/16	182TC	8 7/16	6 3/4	13 7/8
EVMSU(L)3-17	5	184TC	8 1/2	6 7/8	15 7/16	182TC	8 7/16	6 3/4	13 7/8	
EVMSU(L)3-19	5	184TC	8 1/2	6 7/8	15 7/16	182TC	8 7/16	6 3/4	13 7/8	
EVMSU(L)3-20	5	184TC	8 1/2	6 7/8	15 7/16	182TC	8 7/16	6 3/4	13 7/8	
EVMSU(L)3-21	5	184TC	8 1/2	6 7/8	15 7/16	182TC	8 7/16	6 3/4	13 7/8	
EVMSU(L)3-22	5	184TC	8 1/2	6 7/8	15 7/16	182TC	8 7/16	6 3/4	13 7/8	
EVMSU(L)3-23	5	184TC	8 1/2	6 7/8	15 7/16	182TC	8 7/16	6 3/4	13 7/8	

NOTE: Motor dimensions (B, C and H3) are provided for reference only and should be verified based on motor manufacturer specifications.

Requires 145TC motor bracket

MOTOR DIMENSIONS
EVMSU(L)5-10-15-20

Pump		TEFC motor				ODP motor				
Pump Model	Horsepower	NEMA frame size	Dimensions [inches]			NEMA frame size	Dimensions [inches]			
			B	C	H3		B	C	H3	
5	EVMSU5 2	1	56C	7 1/4	5 1/4	13 5/8	56C	6 3/16	5 1/16	11 1/8
	EVMSU5 3	1.5	56C	7 1/4	5 1/4	13 5/8	56C	7 1/4	5 5/8	13 9/16
	EVMSU5 4	2	56C	7 1/4	5 1/4	13 9/16	56C	6 1/4	5 1/16	11 5/16
	EVMSU5 5	3	182TC	7 1/4	5 3/4	13 15/16	145TC	7 3/16	5 5/8	11 1/8
	EVMSU5 6	3	182TC	7 1/4	5 3/4	13 15/16	145TC	7 3/16	5 5/8	11 1/8
	EVMSU5 7	5	184TC	8 1/2	6 7/8	15 7/16	182TC	8 7/16	6 3/4	13 7/8
	EVMSU5 8	5	184TC	8 1/2	6 7/8	15 7/16	182TC	8 7/16	6 3/4	13 7/8
	EVMSU5 9	5	184TC	8 1/2	6 7/8	15 7/16	182TC	8 7/16	6 3/4	13 7/8
	EVMSU5 10	5	184TC	8 1/2	6 7/8	15 7/16	182TC	8 7/16	6 3/4	13 7/8
	EVMSU5 11	5	184TC	8 1/2	6 7/8	15 7/16	182TC	8 7/16	6 3/4	13 7/8
	EVMSU5 12	7.5	213TC	10 5/16	8 1/16	18 3/16	-	-	-	-
	EVMSU5 13	7.5	213TC	10 5/16	8 1/16	18 3/16	-	-	-	-
	EVMSU5 14	7.5	213TC	10 5/16	8 1/16	18 3/16	-	-	-	-
	EVMSU5 15	7.5	213TC	10 5/16	8 1/16	18 3/16	-	-	-	-
EVMSU5 16	7.5	213TC	10 5/16	8 1/16	18 3/16	-	-	-	-	
EVMSU5 17	7.5	213TC	10 5/16	8 1/16	18 3/16	-	-	-	-	
EVMSU5 19	10	215TC	10 5/16	8 1/16	18 3/16	213TC	9 5/8	7 15/16	16 9/16	
10	EVMSU10 1	1	56C	7 1/4	5 1/4	13 5/8	56C	6 3/16	5 1/16	11 1/8
	EVMSU10 2	2	56C	7 1/4	5 1/4	13 9/16	56C	6 1/4	5 1/16	11 5/16
	EVMSU10 3	3	182TC	7 1/4	5 3/4	13 15/16	145TC	7 3/16	5 5/8	11 1/8
	EVMSU10 4	5	184TC	8 1/2	6 7/8	15 7/16	182TC	8 7/16	6 3/4	13 7/8
	EVMSU10 5	5	184TC	8 1/2	6 7/8	15 7/16	182TC	8 7/16	6 3/4	13 7/8
	EVMSU10 6	5	184TC	8 1/2	6 7/8	15 7/16	182TC	8 7/16	6 3/4	13 7/8
	EVMSU10 7	7.5	184TC	8 5/8	6 7/8	15 7/16	184TC	8 1/2	6 3/4	12 3/8
	EVMSU10 8	7.5	184TC	8 5/8	6 7/8	15 7/16	184TC	8 1/2	6 3/4	12 3/8
	EVMSU10 9	7.5	184TC	8 5/8	6 7/8	15 7/16	184TC	8 1/2	6 3/4	12 3/8
	EVMSU10 10	10	215TC	10 5/16	8 1/16	18 3/16	213TC	9 5/8	7 15/16	16 9/16
	EVMSU10 11	10	215TC	10 5/16	8 1/16	18 3/16	213TC	9 5/8	7 15/16	16 9/16
	EVMSU10 12	10	215TC	10 5/16	8 1/16	18 3/16	213TC	9 5/8	7 15/16	16 9/16
EVMSU10 14	15	215TC	10 5/16	8 1/16	18 3/16	215TC	9 5/8	7 15/16	16 9/16	
EVMSU10 15	15	215TC	10 5/16	8 1/16	18 3/16	215TC	9 5/8	7 15/16	16 9/16	
EVMSU10 16	15	215TC	10 5/16	8 1/16	18 3/16	215TC	9 5/8	7 15/16	16 9/16	
15	EVMSU15 1	2	56C	7 1/4	5 1/4	13 9/16	56C	6 1/4	5 1/16	11 5/16
	EVMSU15 2	5	184TC	8 1/2	6 7/8	15 7/16	182TC	8 7/16	6 3/4	13 7/8
	EVMSU15 3	7.5	184TC	8 5/8	6 7/8	15 7/16	184TC	8 1/2	6 3/4	12 3/8
	EVMSU15 4	10	215TC	10 5/16	8 1/16	18 3/16	213TC	9 5/8	7 15/16	16 9/16
	EVMSU15 5	10	215TC	10 5/16	8 1/16	18 3/16	213TC	9 5/8	7 15/16	16 9/16
	EVMSU15 6	15	215TC	10 5/16	8 1/16	18 3/16	215TC	9 5/8	7 15/16	16 9/16
	EVMSU15 7	15	215TC	10 5/16	8 1/16	18 3/16	215TC	9 5/8	7 15/16	16 9/16
	EVMSU15 8	20	256TC	12 7/8	10 1/16	20	254TC	11 1/2	9 1/2	18
	EVMSU15 9	20	256TC	12 7/8	10 1/16	20	254TC	11 1/2	9 1/2	18
	EVMSU15 10	20	256TC	12 7/8	10 1/16	20	254TC	11 1/2	9 1/2	18
	EVMSU15 11	25	284TSC	13 5/8	12 1/8	21 3/4	-	-	-	-
	EVMSU15 12	25	284TSC	13 5/8	12 1/8	21 3/4	-	-	-	-
20	EVMSU20 1	3	182TC	7 1/4	5 3/4	13 15/16	145TC	7 3/16	5 5/8	11 1/8
	EVMSU20 2	5	184TC	8 1/2	6 7/8	15 7/16	182TC	8 7/16	6 3/4	13 7/8
	EVMSU20 3	7.5	184TC	8 5/8	6 7/8	15 7/16	184TC	8 1/2	6 3/4	12 3/8
	EVMSU20 4	10	215TC	10 5/16	8 1/16	18 3/16	213TC	9 5/8	7 15/16	16 9/16
	EVMSU20 5	15	215TC	10 5/16	8 1/16	18 3/16	215TC	9 5/8	7 15/16	16 9/16
	EVMSU20 6	15	215TC	10 5/16	8 1/16	18 3/16	215TC	9 5/8	7 15/16	16 9/16
	EVMSU20 7	20	256TC	12 7/8	10 1/16	20	254TC	11 1/2	9 1/2	18
	EVMSU20 8	20	256TC	12 7/8	10 1/16	20	254TC	11 1/2	9 1/2	18
	EVMSU20 9	25	284TSC	13 5/8	12 1/8	21 3/4	-	-	-	-
	EVMSU20 10	25	284TSC	13 5/8	12 1/8	21 3/4	-	-	-	-

NOTE: Motor dimensions (B, C and H3) are provided for reference only and should be verified based on motor manufacturer specifications.

 Requires 145TC motor bracket

**TECHNICAL DATA
DIMENSIONS**

MODELS EVMUL32 1 – EVMUL32 4-3
 EVMUL45 1-1 – EVMUL45 3
 EVMUG32 1 – EVMUG32 4-3
 EVMUG45 1-1 – EVMUG45 3

Approximate Motor Dimensions C*
 for 3 phase, TEFC, NEMA Motors

HP	Frame Size	C* Inches	Motor Wt LBS.
5	184TC	13.80	69
7.5	184TC	15.30	88
10	215TC	15.26	122
15	215TC	16.39	143
20	256TC	16.32	221

Note: C may vary slightly by manufacturer*

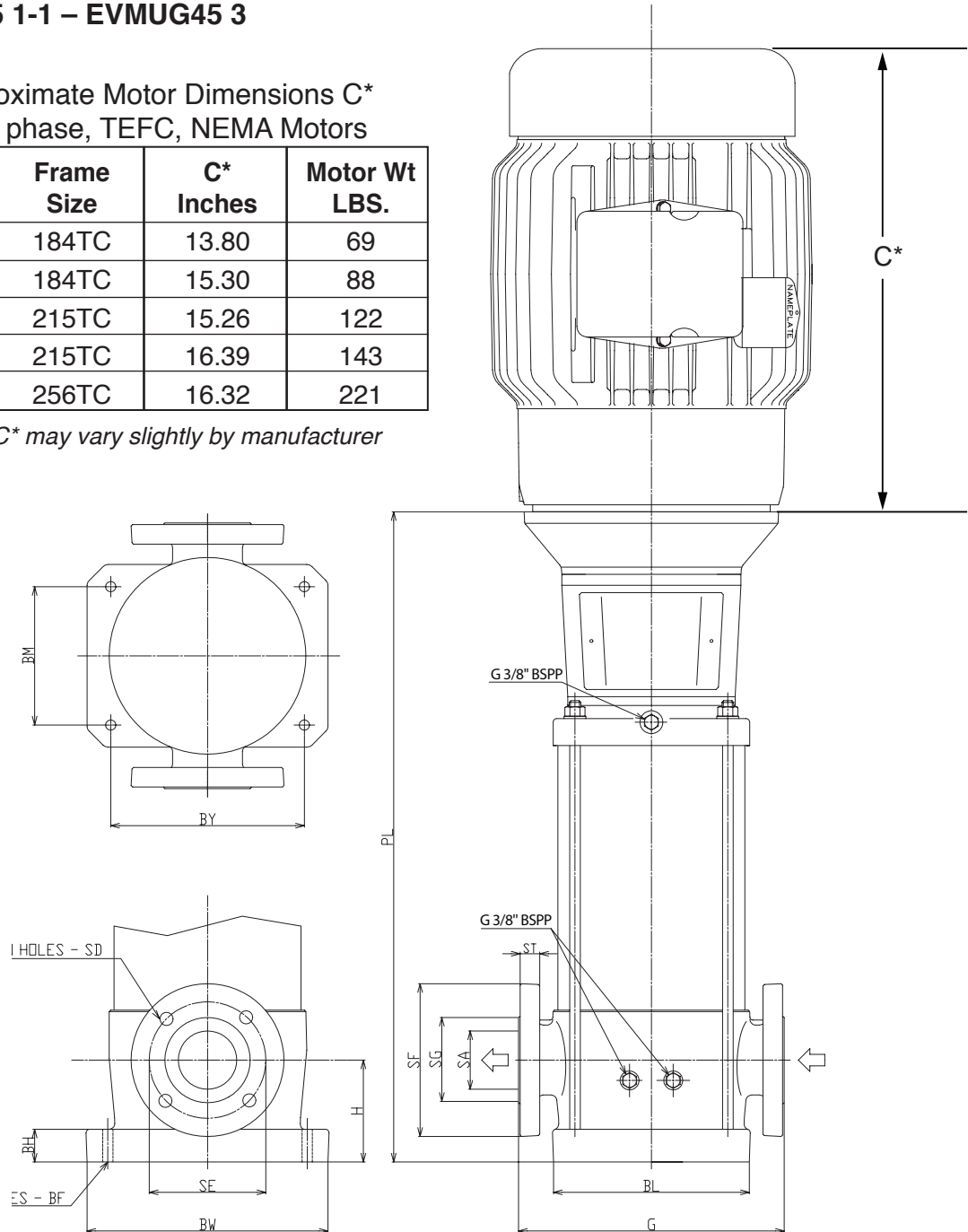

Flange Detail:

EVMU32 2 1/2" 150Lb. ANSI Compatible

EVMU45 3" 150Lb. ANSI Compatible

Refer to page 33 for dimension details.

TECHNICAL DATA

DIMENSIONS

MODELS EVMUG64 1-1 – EVMUG64 3

EVMUL64 1-1 – EVMUL64 3

Approximate Motor Dimensions C*
for 3 phase, TEFC, NEMA Motors

HP	Frame Size	C* Inches	Motor Wt LBS.
10	215TC	15.26	122
15	215TC	16.39	143
20	256TC	16.32	221
25	284TSC	19.03	371
30	286TSC	19.03	403
40	324TSC	23.39	422

Note: C may vary slightly by manufacturer*

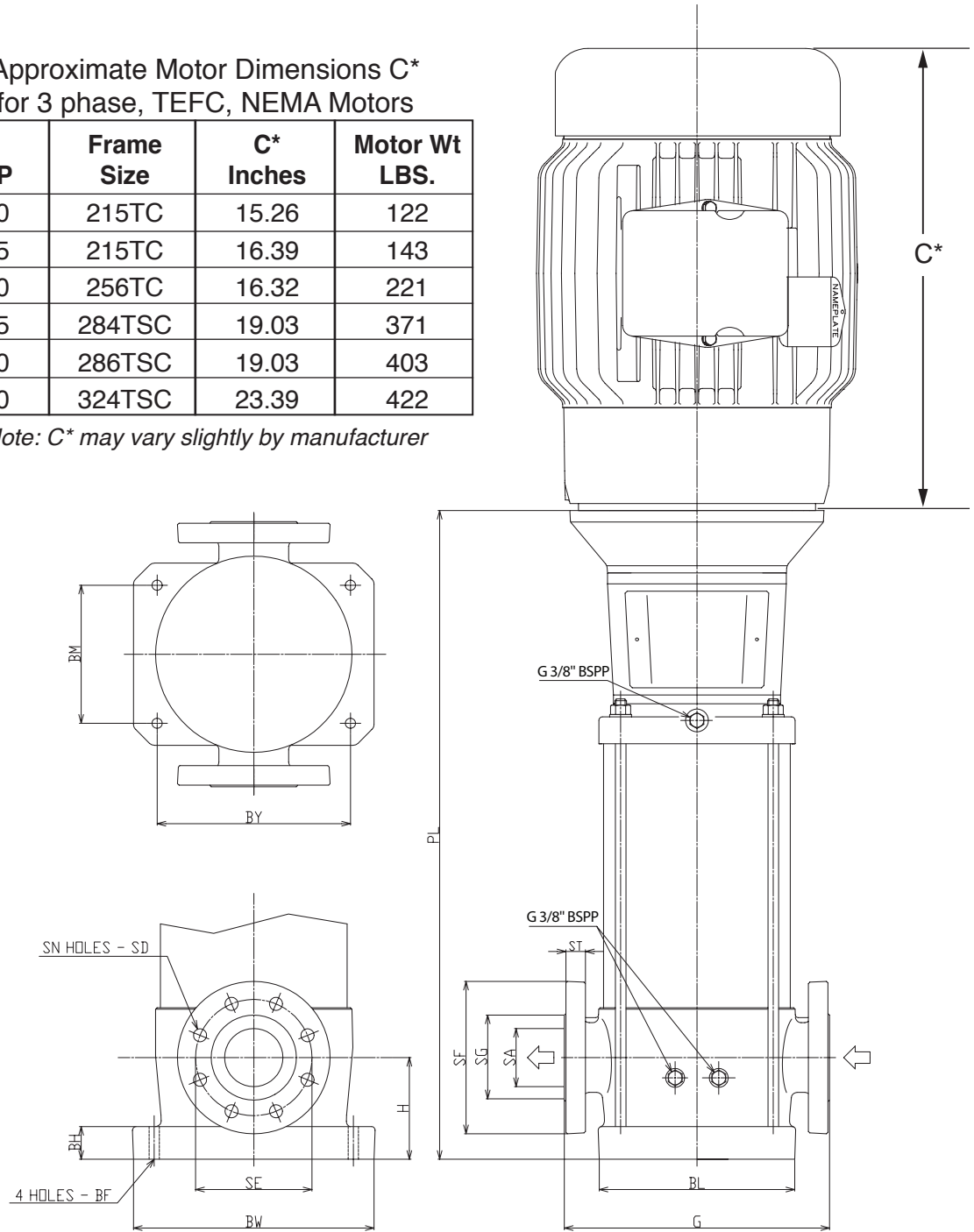

Flange Detail:

EVMU64 4" 150Lb. ANSI Compatible

Refer to page 33 for dimension details.

TECHNICAL DATA

DIMENSIONS

MODELS EVMUG32 5 – EVMUG32 10-1
 EVMUG45 4-1 – EVMUG45 7-2
 EVMUG64 4-2 – EVMUG64 4
 EVMUL32 5 – EVMUL32 10-1
 EVMUL45 4-1 – EVMUL45 7-2
 EVMUL64 4-2 – EVMUL64 4

Approximate Motor Dimensions C*
for 3 phase, TEFC, NEMA Motors

HP	Frame Size	C* Inches	Motor Wt LBS.
20	256TC	16.32	221
25	284TSC	19.03	371
30	286TSC	19.03	403
40	324TSC	23.39	422
50	326TSC	23.39	962

Note: C* may vary slightly by manufacturer

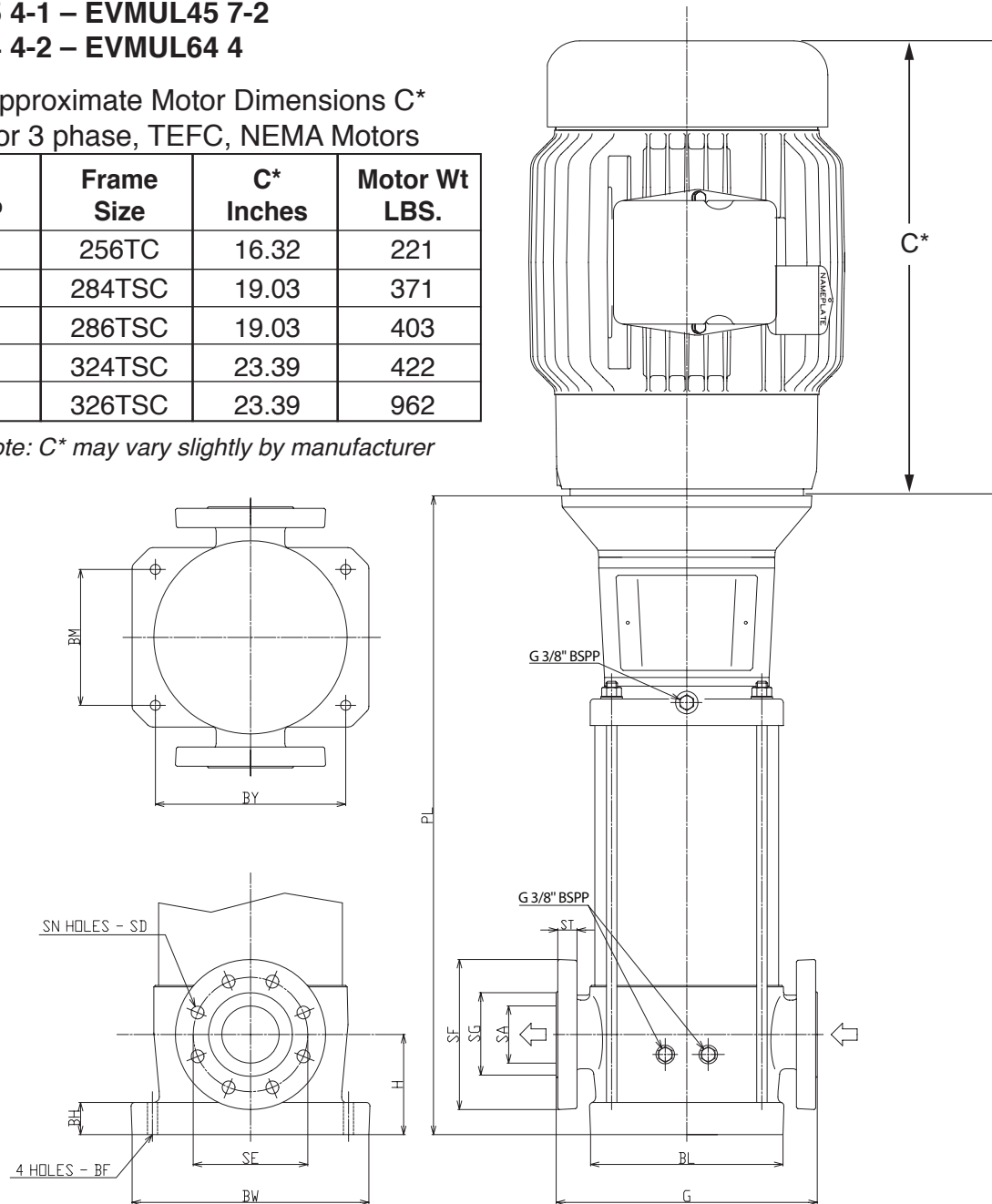

Flange Detail:

EVMU32 2 1/2" 300Lb. ANSI Compatible
 EVMU45 3" 300Lb. ANSI Compatible
 EVMU64 4" 300Lb. ANSI Compatible

Refer to page 33 for dimension details.

DIMENSION TABLE

Pump Type					Dimensions (inches)							
Model	HP	Weight Lbs. †	Motor Frame*	PL	H	G	ST	SA	SG	SF	SD	SN
32 1	5	117	184TC	18 3/16	4 9/64	12 19/32	25/32	2 9/16	4 21/64	7	25/32	4
32 2-2	7 1/2	126	184TC	20 19/32								
32 3-2	10	170	215TC	22 21/32								
32 3	15	172	215TC	27 41/64								
32 4-3	15	176	215TC	29 17/32								
32 5	20	194	256TC	31 27/64								
32 6	25	200	284TSC	33 7/64								
32 7	30	207	286TSC	35								
32 8-3	30	225	286TSC	36 57/64								
32 9	40	240	324TSC	39 3/8								
32 10-1	40	247	324TSC	41 17/64								
45 1-1	7 1/2	148	184TC	21 29/64	5 33/64	14 3/8	15/16	3 5/32	4 23/32	7 1/2	25/32	4
45 1	10	152	215TC	21 29/64								
45 2-1	15	192	215TC	29 29/64								
45 3-2	20	207	256TC	32 9/32								
45 3	25	207	284TSC	32 2/32								
45 4-1	30	229	286TSC	34 59/64								
45 5	40	260	324TSC	38 11/32								
45 6	50	276	326TSC	41 3/16								
45 7-2	50	287	326TSC	44 1/64								
64 1-1	10	179	215TC	21 29/64								
64 1	15	201	215TC	26 5/8	5 33/64	14 3/8	1 1/32	3 15/16	5 33/64	9	25/32	8
64 2-1	20	213	256TC	29 29/64								
64 2	25	214	284TSC	29 1/4								
64 3-2	30	221	286TSC	32 3/32								
64 3	40	223	324TSC	32 11/16								
64 4-2	40	245	324TSC	35 33/64								
64 4	50	251	326TSC	35 33/64								
											1 21/64	

Pump Type				Dimensions (inches)						
Model	HP	Motor Frame*	SE	BM	BY1	BL	BW	BF	BH	
32 1	5	184TC	5 1/2	6 11/16	9 29/64	8 17/64	11 1/32	35/64	1 3/8	
32 2-2	7 1/2	184TC								
32 3-2	10	215TC								
32 3	15	215TC								
32 4-3	15	215TC								
32 5	20	256TC	5 7/8							
32 6	25	284TSC								
32 7	30	286TSC								
32 8-3	30	286TSC								
32 9	40	324TSC								
32 10-1	40	324TSC								
45 1-1	7 1/2	184TC	6	7 31/64	10 15/32	9 57/64	13 1/32	35/64	1 49/64	
45 1	10	215TC								
45 2-1	15	215TC								
45 3-2	20	256TC								
45 3	25	284TSC								
45 4-1	30	286TSC	6 5/8							
45 5	40	324TSC								
45 6	50	326TSC								
45 7-2	50	326TSC								
64 1-1	10	215TC								7 1/2
64 1	15	215TC								
64 2-1	20	256TC								
64 2	25	284TSC								
64 3-2	30	286TSC								
64 3	40	324TSC	7 7/8							
64 4-2	40	324TSC								
64 4	50	326TSC								

*Motor frame for Three Phase TEFC only. Consult factory for single phase and alternate enclosures.

† Bare Pump only.



SECTIONAL VIEW
EVMSU(L)1

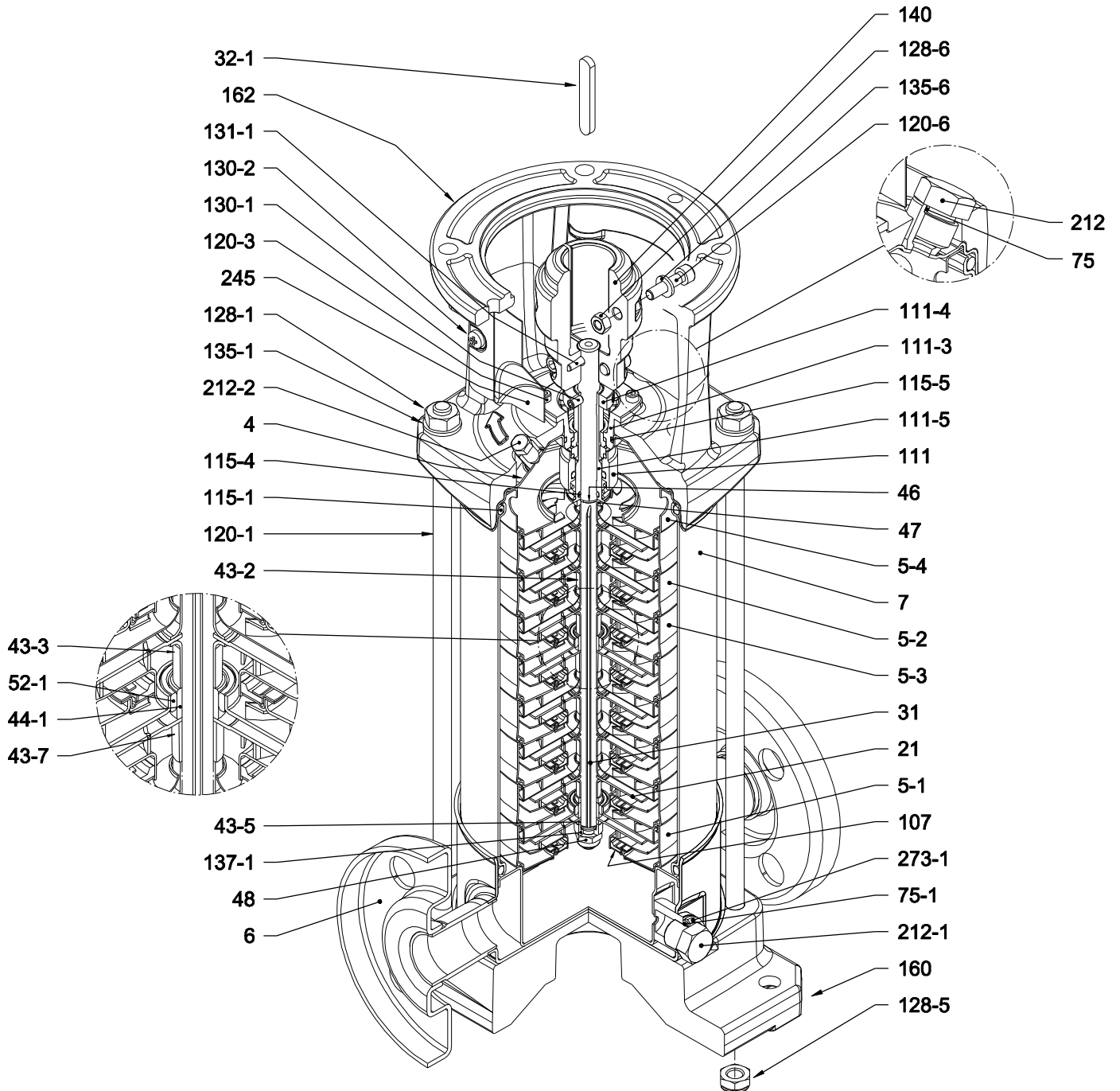

with Round (ANSI Compatible) flange (F)

PIPE CONNECTION
EVMSU(L)1

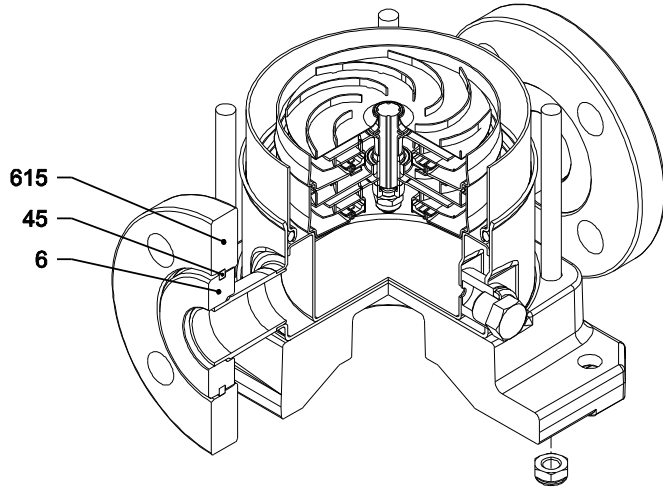

with Loose round ANSI compatible flange (L)

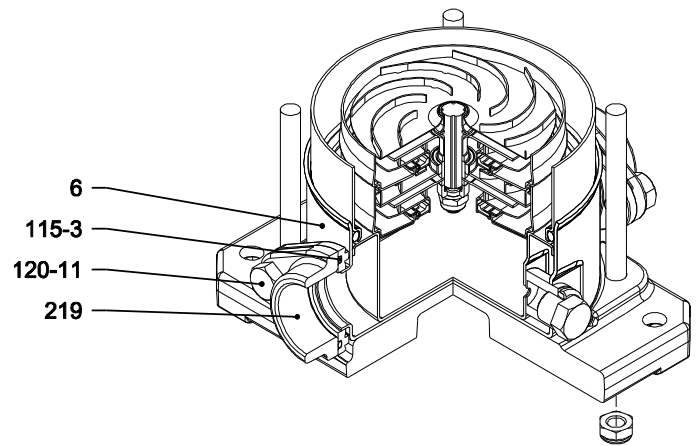

with Oval flange (N)

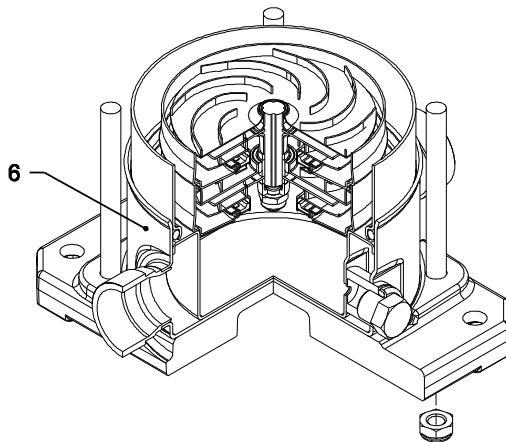

with victaulic connection (V)

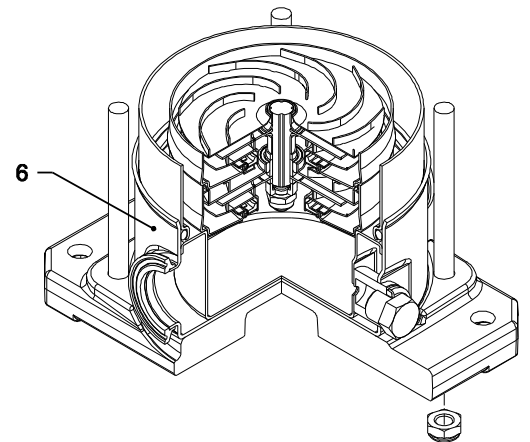

with Clamp connection (C)

SECTIONAL VIEW PART REFERENCE
EVMSU(L)1

N°	PART NAME	MATERIAL		DIMENSIONS [mm]	STANDARD
		EVMSU	EVMSUL		
4	Casing cover	AISI 304 (EN 1.4301)	AISI 316 (EN 1.4401)		
5-1	Suction casing	AISI 304 (EN 1.4301)	AISI 316 (EN 1.4401)		
5-2	Intermediate Casing	AISI 304 (EN 1.4301)	AISI 316 (EN 1.4401)		
5-3	Intermediate casing bearing	AISI 304 (EN 1.4301)	AISI 316 (EN 1.4401)		
5-4	Discharge casing	AISI 304 (EN 1.4301)	AISI 316 (EN 1.4401)		
6	Bottom casing	AISI 304 (EN 1.4301)	AISI 316 (EN 1.4401)		
7	Outer casing	AISI 304 (EN 1.4301)	AISI 316L (EN 1.4404)		
21	Impeller	AISI 304 (EN 1.4301)	AISI 316 (EN 1.4401)		
31	Shaft	AISI 304 (EN 1.4301)	AISI 316L (EN 1.4404)		
32-1	Adjuster Key	AISI 304 (EN 1.4301)			
43-2	Shaft sleeve (intermediate)	AISI 304 (EN 1.4301)	AISI 316L (EN 1.4404)	12x10	
43-3	Shaft sleeve (bearing)	AISI 304 (EN 1.4301)	AISI 316 (EN 1.4401)		
43-5	Shaft sleeve (last stage)	AISI 304 (EN 1.4301)	AISI 316 (EN 1.4401)		
43-7	Spacer	AISI 304 (EN 1.4301)	AISI 316L (EN 1.4404)	12x10	
44-1	Shaft sleeve bearing	Tungsten carbide			
45	Flange holder	AISI 304 (EN 1.4301)			
46	Ring (mechanical seal)	AISI 316L (EN 1.4404)			
47	Ring Holder	AISI 304 (EN 1.4301)	AISI 316 (EN 1.4401)		
48	Impeller nut	A2-70 UNI 7323 with inox insert	A4-70 UNI 7323 with inox insert	M8	
52-1	Bearing	Tungsten carbide			
75	O-Ring (plug)	FPM		D. 12.37x2.62	OR 3050
75-1	O-Ring (plug)	FPM			
107	Liner ring	AISI 304 (EN 1.4301) + PPS	AISI 316 (EN 1.4401) + PPS		
111	Mechanical Seal	SiC/Carbon/FPM			
111-3	Mechanical seal seat	AISI 304 (EN 1.4301)	AISI 316 (EN 1.4401)		
111-4	Seal holder	AISI 304 (EN 1.4301)			
111-5	Mechanical seal cartridge	AISI 304 (EN 1.4301)	AISI 316 (EN 1.4401)		
115-1	O-Ring (outer casing)	FPM		D. 129.54x5.34	OR 6510
115-3	O-Ring	FPM			
115-4	O-Ring (cartridge sleeve)	FPM		D. 11.91x2.62	OR 115
115-5	O-Ring (seal cover)	FPM		D. 32.99x2.62	OR 3131
120-1	Tie-rod	Galvanized steel 6.8 strength class ISO 898/1		M10	
120-3	Screw	A2-70 UNI 7323		M4x10	ISO 4762
120-6	Screw for coupling	Galvanized steel		M6x25	ISO 4762
120-11	Screw for counterflange	A2-70 UNI 7323			
128-1	Nut for tie rod	Galvanized steel		M10	UNI 5588
128-5	Nut for tie rod	A2-70 UNI 7323		M10	UNI 7474
128-6	Nut for coupling	Galvanized steel		M6	ISO 4032
130-1	Set screw	A2-70 UNI 7323		M5x8	UNI 5923
130-2	Screw for coupling guard	A2-70 UNI 7323		M5x6	UNI 7687
131-1	Pin for shaft	Carbon Steel		D. 4x32	UNI 4838
135-1	Washer	Galvanized steel		D. 10.5x21x2	UNI 6592
135-6	Washer	Carbon Steel		Ø6	
137-1	Impeller spacer	AISI 304 (EN 1.4301)	AISI 316 (EN 1.4401)		
140	Coupling	up to 5 HP Die cast Aluminium EN AB-AISI11Cu2 (Fe)			
160	Base	Die cast Aluminium EN AB-AISI11Cu2 (Fe)			
162	Motor bracket	Cast iron EN-GJL-200-EN 1561			
212	Plug	AISI 304 (EN 1.4301)	AISI 316 (EN 1.4401)	G 3/8 (BSPP)	
212-1	Plug	AISI 304 (EN 1.4301)	AISI 316 (EN 1.4401)	G 3/8 (BSPP)	
212-2	Venting plug	AISI 316L (EN 1.4404)			
219	Counter flange	AISI 304 (EN 1.4301)	AISI 316 (EN 1.4401)		
245	Coupling guard	AISI 304 (EN 1.4301)			
273-1	Plug Washer	AISI 304 (EN 1.4301)	AISI 316 (EN 1.4401)		
615	Flange	Nodular Cast Iron			

PART QUANTITY FOR MODEL
EVMSU(L)1

Pump Type	N°																															
	4	5-1	5-2	5-3	5-4	6	7	21	31	32-1	43-2	43-3	43-5	43-7	44-1	45**	46	47	48	52-1	75	75-1	107	111	111-3	111-4	111-5	115-1	115-3*	115-4	115-5	
EVMSU(L)1 2	1	1	/	1	1	1	1	2	1	1	/	1	/	/	1	4	2	1	1	1	1	2	2	1	1	1	1	1	2	2	1	1
EVMSU(L)1 3	1	1	1	1	1	1	1	3	1	1	3	1	/	/	1	4	2	1	1	1	1	2	3	1	1	1	1	1	2	2	1	1
EVMSU(L)1 4	1	1	2	1	1	1	1	4	1	1	5	1	/	/	1	4	2	1	1	1	1	2	4	1	1	1	1	1	2	2	1	1
EVMSU(L)1 5	1	1	3	1	1	1	1	5	1	1	7	1	1	/	1	4	2	1	1	1	1	2	5	1	1	1	1	1	2	2	1	1
EVMSU(L)1 6	1	1	4	1	1	1	1	6	1	1	9	1	/	/	1	4	2	1	1	1	1	2	6	1	1	1	1	1	2	2	1	1
EVMSU(L)1 7	1	1	5	1	1	1	1	7	1	1	11	1	/	/	1	4	2	1	1	1	1	2	7	1	1	1	1	1	2	2	1	1
EVMSU(L)1 8	1	1	6	1	1	1	1	8	1	1	13	1	/	/	1	4	2	1	1	1	1	2	8	1	1	1	1	1	2	2	1	1
EVMSU(L)1 9	1	1	7	1	1	1	1	9	1	1	15	1	1	/	1	4	2	1	1	1	1	2	9	1	1	1	1	1	2	2	1	1
EVMSU(L)1 10	1	1	8	1	1	1	1	10	1	1	17	1	/	/	1	4	2	1	1	1	1	2	10	1	1	1	1	1	2	2	1	1
EVMSU(L)1 11	1	1	9	1	1	1	1	11	1	1	19	1	/	/	1	4	2	1	1	1	1	2	11	1	1	1	1	1	2	2	1	1
EVMSU(L)1 12	1	1	10	1	1	1	1	12	1	1	21	1	/	/	1	4	2	1	1	1	1	2	12	1	1	1	1	1	2	2	1	1
EVMSU(L)1 13	1	1	10	2	1	1	1	13	1	1	20	2	1	1	2	4	2	1	1	2	1	2	13	1	1	1	1	1	2	2	1	1
EVMSU(L)1 14	1	1	11	2	1	1	1	14	1	1	22	2	/	1	2	4	2	1	1	2	1	2	14	1	1	1	1	1	2	2	1	1
EVMSU(L)1 16	1	1	13	2	1	1	1	16	1	1	26	2	/	1	2	4	2	1	1	2	1	2	16	1	1	1	1	1	2	2	1	1
EVMSU(L)1 18	1	1	15	2	1	1	1	18	1	1	30	2	/	1	2	4	2	1	1	2	1	2	18	1	1	1	1	1	2	2	1	1
EVMSU(L)1 20	1	1	17	2	1	1	1	20	1	1	34	2	/	1	2	4	2	1	1	2	1	2	20	1	1	1	1	1	2	/	1	1
EVMSU(L)1 22	1	1	19	2	1	1	1	22	1	1	38	2	/	1	2	4	2	1	1	2	1	2	22	1	1	1	1	1	2	/	1	1
EVMSU(L)1 24	1	1	21	2	1	1	1	24	1	1	42	2	/	1	2	4	2	1	1	2	1	2	24	1	1	1	1	1	2	/	1	1
EVMSU(L)1 26	1	1	23	2	1	1	1	26	1	1	46	2	/	1	2	4	2	1	1	2	1	2	26	1	1	1	1	1	2	/	1	1
EVMSU(L)1 27	1	1	24	2	1	1	1	27	1	1	48	2	/	1	2	4	2	1	1	2	1	2	27	1	1	1	1	1	2	/	1	1
EVMSU(L)1 29	1	1	26	2	1	1	1	29	1	1	52	2	/	1	2	4	2	1	1	2	1	2	29	1	1	1	1	1	2	/	1	1

Pump Type	N°																						
	120-1	120-3	120-6	120-11*	128-1	128-5	128-6	130-1	130-2	131-1	135-1	135-6	137-1	140	160	162	212	212-1	212-2	219*	245	273-1	615**
EVMSU(L)1 2	4	4	4	4	4	4	4	3	4	1	4	4	1	2	1	1	1	2	1	2	2	2	2
EVMSU(L)1 3	4	4	4	4	4	4	4	3	4	1	4	4	1	2	1	1	1	2	1	2	2	2	2
EVMSU(L)1 4	4	4	4	4	4	4	4	3	4	1	4	4	1	2	1	1	1	2	1	2	2	2	2
EVMSU(L)1 5	4	4	4	4	4	4	4	3	4	1	4	4	1	2	1	1	1	2	1	2	2	2	2
EVMSU(L)1 6	4	4	4	4	4	4	4	3	4	1	4	4	1	2	1	1	1	2	1	2	2	2	2
EVMSU(L)1 7	4	4	4	4	4	4	4	3	4	1	4	4	1	2	1	1	1	2	1	2	2	2	2
EVMSU(L)1 8	4	4	4	4	4	4	4	3	4	1	4	4	1	2	1	1	1	2	1	2	2	2	2
EVMSU(L)1 9	4	4	4	4	4	4	4	3	4	1	4	4	1	2	1	1	1	2	1	2	2	2	2
EVMSU(L)1 10	4	4	4	4	4	4	4	3	4	1	4	4	1	2	1	1	1	2	1	2	2	2	2
EVMSU(L)1 11	4	4	4	4	4	4	4	3	4	1	4	4	1	2	1	1	1	2	1	2	2	2	2
EVMSU(L)1 12	4	4	4	4	4	4	4	3	4	1	4	4	1	2	1	1	1	2	1	2	2	2	2
EVMSU(L)1 13	4	4	4	4	4	4	4	3	4	1	4	4	1	2	1	1	1	2	1	2	2	2	2
EVMSU(L)1 14	4	4	4	4	4	4	4	3	4	1	4	4	1	2	1	1	1	2	1	2	2	2	2
EVMSU(L)1 16	4	4	4	4	4	4	4	3	4	1	4	4	1	2	1	1	1	2	1	2	2	2	2
EVMSU(L)1 18	4	4	4	4	4	4	4	3	4	1	4	4	1	2	1	1	1	2	1	2	2	2	2
EVMSU(L)1 20	4	4	4	/	4	4	4	3	4	1	4	4	1	2	1	1	1	2	1	/	2	2	2
EVMSU(L)1 22	4	4	4	/	4	4	4	3	4	1	4	4	1	2	1	1	1	2	1	/	2	2	2
EVMSU(L)1 24	4	4	4	/	4	4	4	3	4	1	4	4	1	2	1	1	1	2	1	/	2	2	2
EVMSU(L)1 26	4	4	4	/	4	4	4	3	4	1	4	4	1	2	1	1	1	2	1	/	2	2	2
EVMSU(L)1 27	4	4	4	/	4	4	4	3	4	1	4	4	1	2	1	1	1	2	1	/	2	2	2
EVMSU(L)1 29	4	4	4	/	4	4	4	3	4	1	4	4	1	2	1	1	1	2	1	/	2	2	2

* only for Oval flange (N)
** only for Loose round flange (L)

SECTIONAL VIEW
EVMSU(L)3

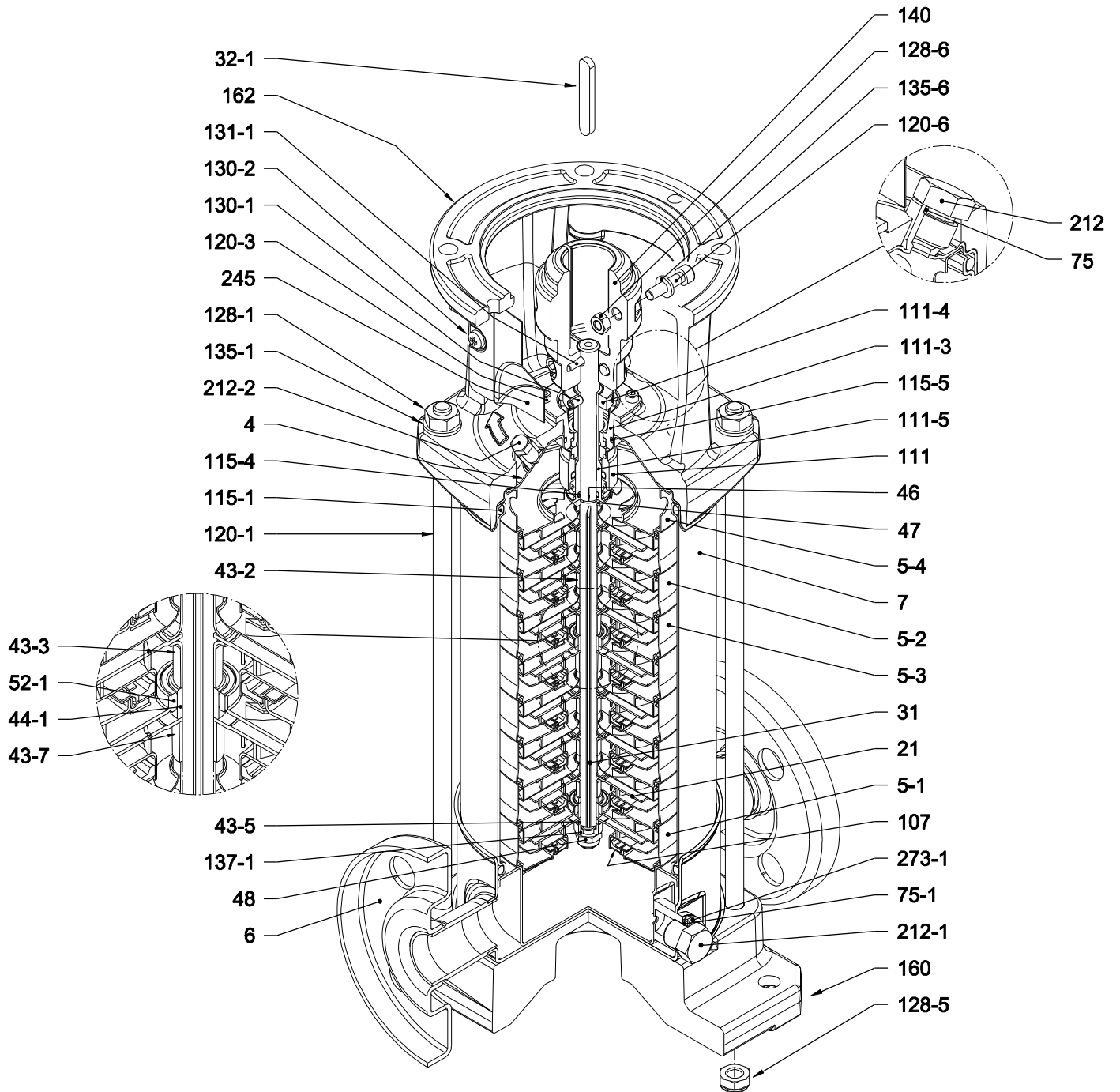

with Round (ANSI Compatible) flange (F)

PIPE CONNECTION
EVMSU(L)3

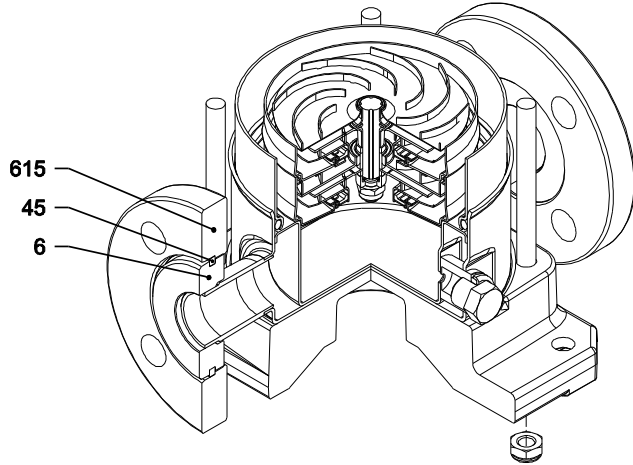

with Loose round ANSI compatible flange (L)

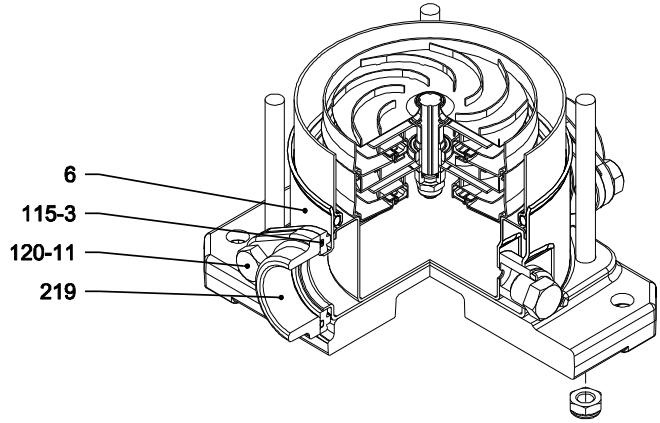

with Oval flange (N)

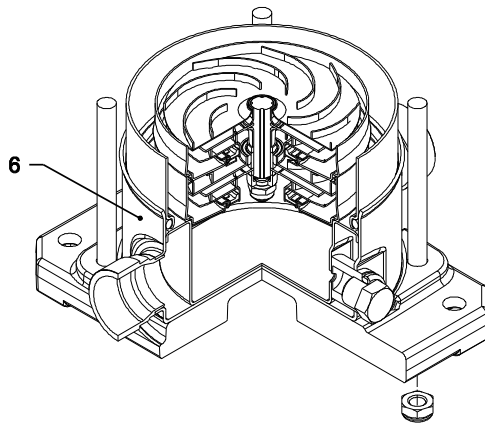

with victaulic connection (V)

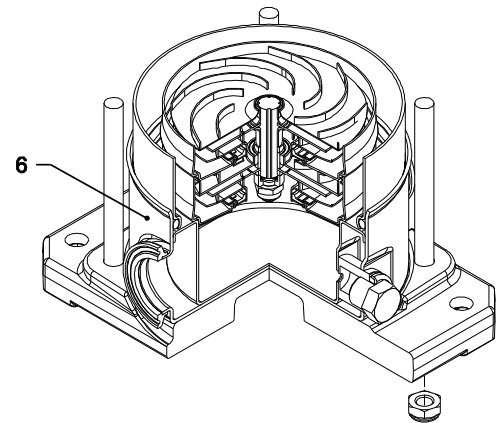

with Clamp connection (C)

SECTIONAL VIEW PART REFERENCE
EVMSU(L)3

N°	PART NAME	MATERIAL		DIMENSIONS [mm]	STANDARD
		EVMSU	EVMSUL		
4	Casing cover	AISI 304 (EN 1.4301)	AISI 316 (EN 1.4401)		
5-1	Suction casing	AISI 304 (EN 1.4301)	AISI 316 (EN 1.4401)		
5-2	Intermediate Casing	AISI 304 (EN 1.4301)	AISI 316 (EN 1.4401)		
5-3	Intermediate casing bearing	AISI 304 (EN 1.4301)	AISI 316 (EN 1.4401)		
5-4	Discharge casing	AISI 304 (EN 1.4301)	AISI 316 (EN 1.4401)		
6	Bottom casing	AISI 304 (EN 1.4301)	AISI 316 (EN 1.4401)		
7	Outer casing	AISI 304 (EN 1.4301)	AISI 316L (EN 1.4404)		
21	Impeller	AISI 304 (EN 1.4301)	AISI 316 (EN 1.4401)		
31	Shaft	AISI 304 (EN 1.4301)	AISI 316L (EN 1.4404)		
32-1	Adjuster Key	AISI 304 (EN 1.4301)			
43-2	Shaft sleeve (intermediate)	AISI 304 (EN 1.4301)	AISI 316L (EN 1.4404)		
43-3	Shaft sleeve (bearing)	AISI 304 (EN 1.4301)	AISI 316 (EN 1.4401)		
43-5	Shaft sleeve (last stage)	AISI 304 (EN 1.4301)	AISI 316 (EN 1.4401)		
43-7	Spacer	AISI 304 (EN 1.4301)		12x10	
44-1	Shaft sleeve bearing	Tungsten carbide			
45	Flange holder	AISI 304 (EN 1.4301)			
46	Ring (mechanical seal)	AISI 316L (EN 1.4404)			
47	Ring Holder	AISI 304 (EN 1.4301)	AISI 316 (EN 1.4401)		
48	Impeller nut	A2-70 UNI 7323 with inox insert	A4-70 UNI 7323 with inox insert	M8	
52-1	Bearing	Tungsten carbide			
75	O-Ring (plug)	FPM		D. 12.37x2.62	OR 3050
75-1	O-Ring (plug)	FPM			
107	Liner ring	AISI 304 (EN 1.4301) + PPS	AISI 316 (EN 1.4401) + PPS		
111	Mechanical Seal	SiC/Carbon/FPM			
111-3	Mechanical seal seat	AISI 304 (EN 1.4301)	AISI 316 (EN 1.4401)		
111-4	Seal holder	AISI 304 (EN 1.4301)			
111-5	Mechanical seal cartridge	AISI 304 (EN 1.4301)	AISI 316 (EN 1.4401)		
115-1	O-Ring (outer casing)	FPM		D. 129.54x5.34	OR 6510
115-3	O-Ring	FPM			
115-4	O-Ring (cartridge sleeve)	FPM		D. 11.91x2.62	OR 115
115-5	O-Ring (seal cover)	FPM		D. 32.99x2.62	OR 3131
120-1	Tie-rod	Galvanized steel 6.8 strength class ISO 898/1		M10	
120-3	Screw	A2-70 UNI 7323		M4x10	ISO 4762
120-6	Screw for coupling	Galvanized steel		M6x25	ISO 4762
120-11	Screw for counterflange	A2-70 UNI 7323			
128-1	Nut for tie rod	Galvanized steel		M10	UNI 5588
128-5	Nut for tie rod	A2-70 UNI 7323		M10	UNI 7474
128-6	Nut for coupling	Galvanized steel		M6	ISO 4032
130-1	Set screw	A2-70 UNI 7323		M5x8	UNI 5923
130-2	Screw for coupling guard	A2-70 UNI 7323		M5x6	UNI 7687
131-1	Pin for shaft	Carbon Steel		D. 4x32	UNI 4838
135-1	Washer	Galvanized steel		D. 10.5x21x2	UNI 6592
135-6	Washer	Carbon Steel		Ø6	
137-1	Impeller spacer	AISI 304 (EN 1.4301)	AISI 316 (EN 1.4401)		
140	Coupling	up to 5 HP Die cast Aluminium EN AB-AISI11Cu2 (Fe)			
160	Base	Die cast Aluminium EN AB-AISI11Cu2 (Fe)			
162	Motor bracket	Cast iron EN-GJL-200-EN 1561			
212	Plug	AISI 304 (EN 1.4301)	AISI 316 (EN 1.4401)	G 3/8 (BSPP)	
212-1	Plug	AISI 304 (EN 1.4301)	AISI 316 (EN 1.4401)	G 3/8 (BSPP)	
212-2	Venting plug	AISI 316L (EN 1.4404)			
219	Counter flange	AISI 304 (EN 1.4301)	AISI 316 (EN 1.4401)		
245	Coupling guard	AISI 304 (EN 1.4301)			
273-1	Plug Washer	AISI 304 (EN 1.4301)	AISI 316 (EN 1.4401)		
615	Flange	Nodular Cast Iron			

PART QUANTITY FOR MODEL
EVMSU(L)3

Pump Type	N°																														
	4	5-1	5-2	5-3	5-4	6	7	21	31	32-1	43-2	43-3	43-5	43-7	44-1	45**	46	47	48	52-1	75	75-1	107	111	111-3	111-4	111-5	115-1	115-3*	115-4	115-5
EVMSU(L)3 2	1	1	/	1	1	1	1	2	1	1	/	1	/	1	1	4	2	1	1	1	1	4	2	1	1	1	1	2	2	1	1
EVMSU(L)3 3	1	1	1	1	1	1	1	3	1	1	3	1	/	1	1	4	2	1	1	1	1	4	3	1	1	1	1	2	2	1	1
EVMSU(L)3 4	1	1	2	1	1	1	1	4	1	1	5	1	/	1	1	4	2	1	1	1	1	4	4	1	1	1	1	2	2	1	1
EVMSU(L)3 5	1	1	3	1	1	1	1	5	1	1	7	1	1	1	1	4	2	1	1	1	1	4	5	1	1	1	1	2	2	1	1
EVMSU(L)3 6	1	1	4	1	1	1	1	6	1	1	9	1	/	1	1	4	2	1	1	1	1	4	6	1	1	1	1	2	2	1	1
EVMSU(L)3 7	1	1	5	1	1	1	1	7	1	1	11	1	/	1	1	4	2	1	1	1	1	4	7	1	1	1	1	2	2	1	1
EVMSU(L)3 8	1	1	6	1	1	1	1	8	1	1	13	1	/	1	1	4	2	1	1	1	1	4	8	1	1	1	1	2	2	1	1
EVMSU(L)3 9	1	1	7	1	1	1	1	9	1	1	15	1	1	1	1	4	2	1	1	1	1	4	9	1	1	1	1	2	2	1	1
EVMSU(L)3 10	1	1	8	1	1	1	1	10	1	1	17	1	/	1	1	4	2	1	1	1	1	4	10	1	1	1	1	2	2	1	1
EVMSU(L)3 11	1	1	9	1	1	1	1	11	1	1	19	1	/	1	1	4	2	1	1	1	1	4	11	1	1	1	1	2	2	1	1
EVMSU(L)3 12	1	1	10	1	1	1	1	12	1	1	21	1	/	1	1	4	2	1	1	1	1	4	12	1	1	1	1	2	2	1	1
EVMSU(L)3 13	1	1	10	2	1	1	1	13	1	1	21	1	1	1	2	4	2	1	1	2	1	4	13	1	1	1	1	2	2	1	1
EVMSU(L)3 14	1	1	11	2	1	1	1	14	1	1	23	1	/	1	2	4	2	1	1	2	1	4	14	1	1	1	1	2	2	1	1
EVMSU(L)3 15	1	1	12	2	1	1	1	15	1	1	25	1	/	1	2	4	2	1	1	2	1	4	15	1	1	1	1	2	2	1	1
EVMSU(L)3 16	1	1	13	2	1	1	1	16	1	1	27	1	/	1	2	4	2	1	1	2	1	4	16	1	1	1	1	2	/	1	1
EVMSU(L)3 17	1	1	14	2	1	1	1	17	1	1	29	1	1	1	2	4	2	1	1	2	1	4	17	1	1	1	1	2	/	1	1
EVMSU(L)3 19	1	1	16	2	1	1	1	19	1	1	33	1	/	1	2	4	2	1	1	2	1	4	19	1	1	1	1	2	/	1	1
EVMSU(L)3 20	1	1	17	2	1	1	1	20	1	1	35	1	/	1	2	4	2	1	1	2	1	4	20	1	1	1	1	2	/	1	1
EVMSU(L)3 21	1	1	18	2	1	1	1	21	1	1	37	1	1	1	2	4	2	1	1	2	1	4	21	1	1	1	1	2	/	1	1
EVMSU(L)3 22	1	1	19	2	1	1	1	22	1	1	39	1	/	1	2	4	2	1	1	2	1	4	22	1	1	1	1	2	/	1	1
EVMSU(L)3 23	1	1	20	2	1	1	1	23	1	1	41	1	/	1	2	4	2	1	1	2	1	4	23	1	1	1	1	2	/	1	1

Pump Type	N°																						
	120-1	120-3	120-6	120-11*	128-1	128-5	128-6	130-1	130-2	131-1	135-1	135-6	137-1	140	160	162	212	212-1	212-2	219*	245	273-1	615**
EVMSU(L)3 2	4	4	4	4	4	4	4	3	4	1	4	4	1	2	1	1	1	2	1	2	2	2	2
EVMSU(L)3 3	4	4	4	4	4	4	4	3	4	1	4	4	1	2	1	1	1	2	1	2	2	2	2
EVMSU(L)3 4	4	4	4	4	4	4	4	3	4	1	4	4	1	2	1	1	1	2	1	2	2	2	2
EVMSU(L)3 5	4	4	4	4	4	4	4	3	4	1	4	4	1	2	1	1	1	2	1	2	2	2	2
EVMSU(L)3 6	4	4	4	4	4	4	4	3	4	1	4	4	1	2	1	1	1	2	1	2	2	2	2
EVMSU(L)3 7	4	4	4	4	4	4	4	3	4	1	4	4	1	2	1	1	1	2	1	2	2	2	2
EVMSU(L)3 8	4	4	4	4	4	4	4	3	4	1	4	4	1	2	1	1	1	2	1	2	2	2	2
EVMSU(L)3 9	4	4	4	4	4	4	4	3	4	1	4	4	1	2	1	1	1	2	1	2	2	2	2
EVMSU(L)3 10	4	4	4	4	4	4	4	3	4	1	4	4	1	2	1	1	1	2	1	2	2	2	2
EVMSU(L)3 11	4	4	4	4	4	4	4	3	4	1	4	4	1	2	1	1	1	2	1	2	2	2	2
EVMSU(L)3 12	4	4	4	4	4	4	4	3	4	1	4	4	1	2	1	1	1	2	1	2	2	2	2
EVMSU(L)3 13	4	4	4	4	4	4	4	3	4	1	4	4	1	2	1	1	1	2	1	2	2	2	2
EVMSU(L)3 14	4	4	4	4	4	4	4	3	4	1	4	4	1	2	1	1	1	2	1	2	2	2	2
EVMSU(L)3 15	4	4	4	4	4	4	4	3	4	1	4	4	1	2	1	1	1	2	1	2	2	2	2
EVMSU(L)3 16	4	4	4	/	4	4	4	3	4	1	4	4	1	2	1	1	1	2	1	/	2	2	2
EVMSU(L)3 17	4	4	4	/	4	4	4	3	4	1	4	4	1	2	1	1	1	2	1	/	2	2	2
EVMSU(L)3 19	4	4	4	/	4	4	4	3	4	1	4	4	1	2	1	1	1	2	1	/	2	2	2
EVMSU(L)3 20	4	4	4	/	4	4	4	3	4	1	4	4	1	2	1	1	1	2	1	/	2	2	2
EVMSU(L)3 21	4	4	4	/	4	4	4	3	4	1	4	4	1	2	1	1	1	2	1	/	2	2	2
EVMSU(L)3 22	4	4	4	/	4	4	4	3	4	1	4	4	1	2	1	1	1	2	1	/	2	2	2
EVMSU(L)3 23	4	4	4	/	4	4	4	3	4	1	4	4	1	2	1	1	1	2	1	/	2	2	2

* only for Oval flange (N)

** only for Loose round flange (L)

SECTIONAL VIEW
EVMSU(L)5

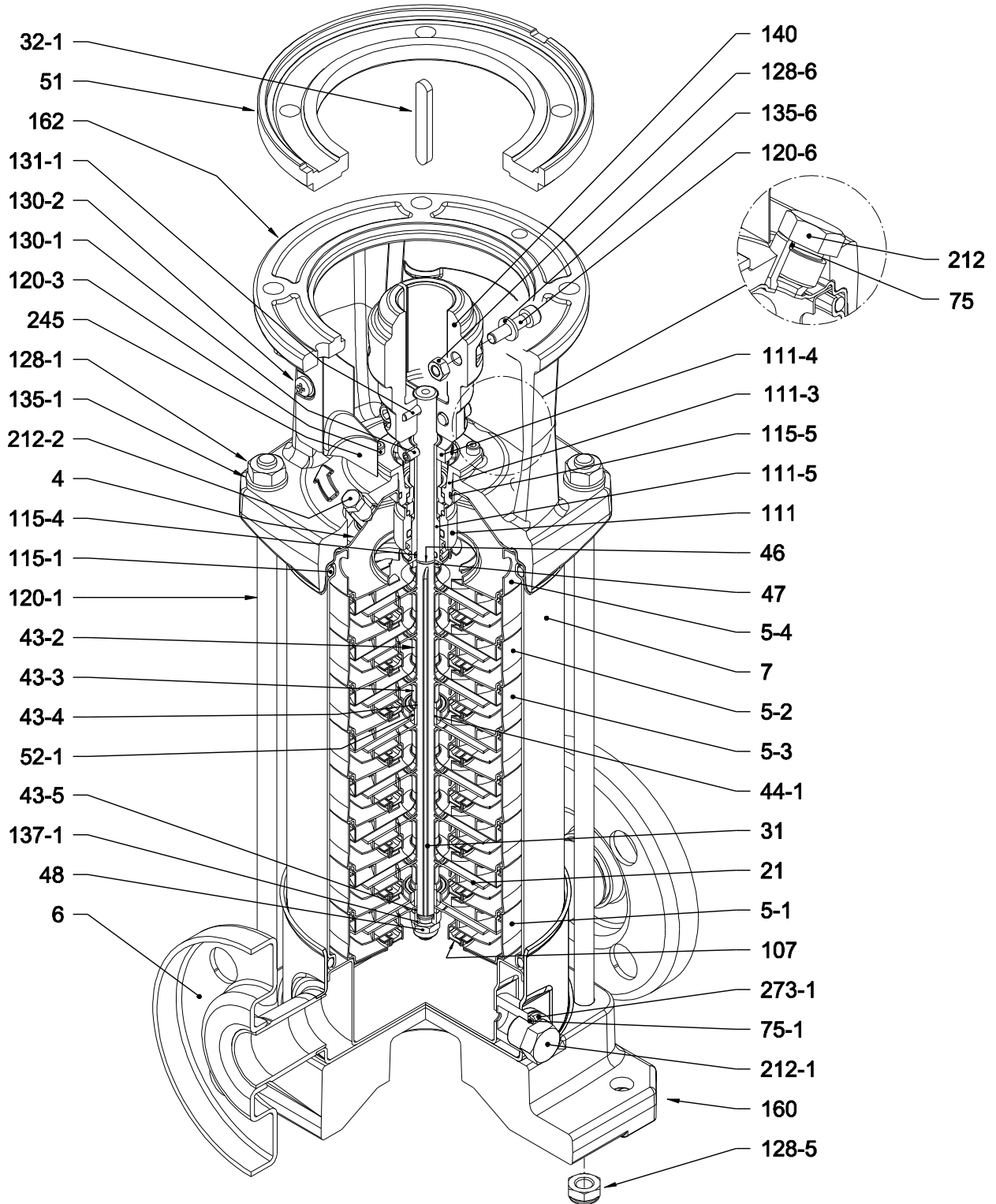

with Round (ANSI Compatible) flange (F)

PIPE CONNECTION

EVMSU(L)5

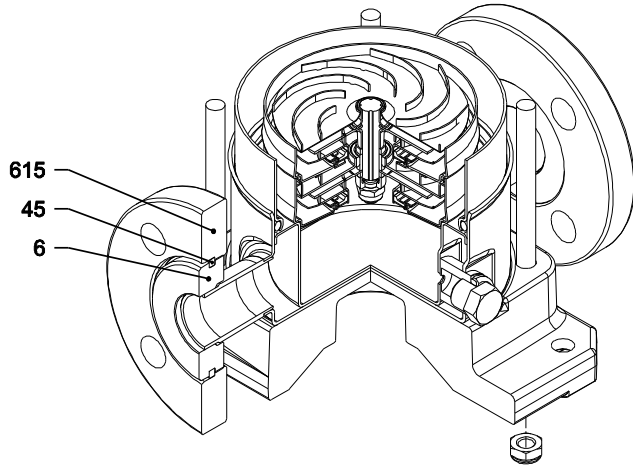

with Loose round ANSI compatible flange (L)

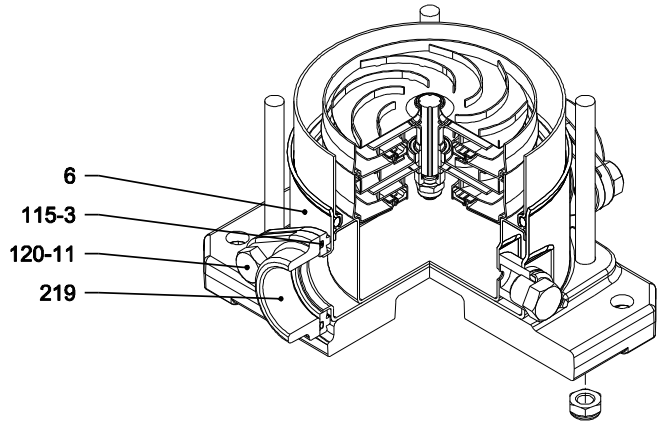

with Oval flange (N)

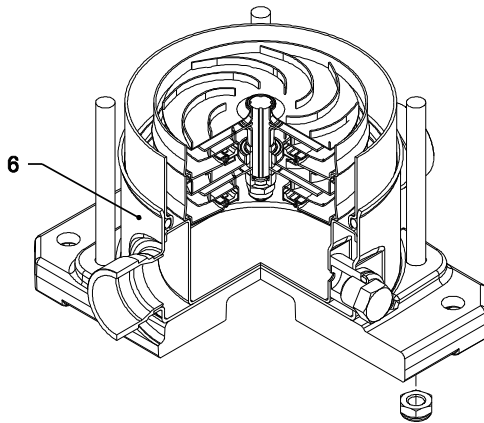

with victaulic connection (V)

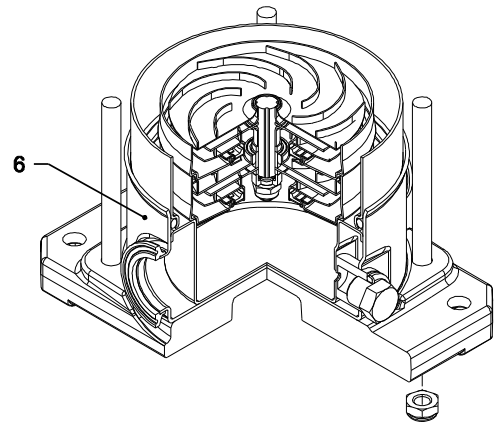

with Clamp connection (C)

SECTIONAL VIEW PART REFERENCE
EVMSU(L)5

N°	PART NAME	MATERIAL		DIMENSIONS [mm]	STANDARD
		EVMSU	EVMSUL		
4	Casing cover	AISI 304 (EN 1.4301)	AISI 316 (EN 1.4401)		
5-1	Suction casing	AISI 304 (EN 1.4301)	AISI 316 (EN 1.4401)		
5-2	Intermediate Casing	AISI 304 (EN 1.4301)	AISI 316 (EN 1.4401)		
5-3	Intermediate casing bearing	AISI 304 (EN 1.4301)	AISI 316 (EN 1.4401)		
5-4	Discharge casing	AISI 304 (EN 1.4301)	AISI 316 (EN 1.4401)		
6	Bottom casing	AISI 304 (EN 1.4301)	AISI 316 (EN 1.4401)		
7	Outer casing	AISI 304 (EN 1.4301)	AISI 316L (EN 1.4404)		
21	Impeller	AISI 304 (EN 1.4301)	AISI 316 (EN 1.4401)		
31	Shaft	AISI 304 (EN 1.4301) - AISI 329A (EN 1.4462)	AISI 316L (EN 1.4404) - AISI 329A (EN 1.4462)		
32-1	Adjuster Key	AISI 304 (EN 1.4301)			
43-2	Shaft sleeve (intermediate)	AISI 304 (EN 1.4301)	AISI 316L (EN 1.4404)		
43-3	Shaft sleeve (bearing)	AISI 304 (EN 1.4301)	AISI 316 (EN 1.4401)		
43-4	Shaft sleeve (adjustment)	AISI 316L (EN 1.4404)			
43-5	Shaft sleeve (last stage)	AISI 304 (EN 1.4301)	AISI 316 (EN 1.4401)		
44-1	Shaft sleeve bearing	Tungsten carbide			
45	Flange holder	AISI 304 (EN 1.4301)			
46	Ring (mechanical seal)	AISI 316L (EN 1.4404)			
47	Ring Holder	AISI 304 (EN 1.4301)	AISI 316 (EN 1.4401)		
48	Impeller nut	A2-70 UNI 7323 with inox insert	A4-70 UNI 7323 with inox insert	M8	
51	Motor adapter	Cast iron EN-GJL-200-EN 1561			
52-1	Bearing	Tungsten carbide			
75	O-Ring (plug)	FPM		D. 12.37x2.62	OR 3050
75-1	O-Ring (plug)	FPM			
107	Liner ring	AISI 304 (EN 1.4301) + PPS	AISI 316 (EN 1.4401) + PPS		
111	Mechanical Seal	SiC/Carbon/FPM			
111-3	Mechanical seal seat	AISI 304 (EN 1.4301)	AISI 316 (EN 1.4401)		
111-4	Seal holder	AISI 304 (EN 1.4301)			
111-5	Mechanical seal cartridge	AISI 304 (EN 1.4301)	AISI 316 (EN 1.4401)		
115-1	O-Ring (outer casing)	FPM		D. 129.54x5.34	OR 6510
115-3	O-Ring	FPM			
115-4	O-Ring (cartridge sleeve)	FPM		D. 11.91x2.62	OR 115
115-5	O-Ring (seal cover)	FPM		D. 32.99x2.62	OR 3131
120-1	Tie-rod	Galvanized steel 6.8 strength class ISO 898/1		M10	
120-3	Screw	A2-70 UNI 7323		M4x10	ISO 4762
120-6	Screw for coupling	Galvanized steel		M6x25	ISO 4762
				M8x20	ISO 4762
120-11	Screw for counterflange	A2-70 UNI 7323			
128-1	Nut for tie rod	Galvanized steel		M10	UNI 5588
128-5	Nut for tie rod	A2-70 UNI 7323		M10	UNI 7474
128-6	Nut for coupling	Galvanized steel		M6	ISO 4032
130-1	Set screw	A2-70 UNI 7323		M5x8	UNI 5923
130-2	Screw for coupling guard	A2-70 UNI 7323		M5x6	UNI 7687
131-1	Pin for shaft	Carbon Steel		D. 4x32	UNI 4838
135-1	Washer	Galvanized steel		D. 10.5x21x2	UNI 6592
135-6	Washer	Carbon Steel		Ø6	
137-1	Impeller spacer	AISI 304 (EN 1.4301)	AISI 316 (EN 1.4401)		
140	Coupling	Die cast Aluminium EN AB-AISI11Cu2 (Fe)			
		Cast Iron			
160	Base	Die cast Aluminium EN AB-AISI11Cu2 (Fe)			
162	Motor bracket	Cast iron EN-GJL-200-EN 1561			
212	Plug	AISI 304 (EN 1.4301)	AISI 316 (EN 1.4401)	G 3/8 (BSPP)	
212-1	Plug	AISI 304 (EN 1.4301)	AISI 316 (EN 1.4401)	G 3/8 (BSPP)	
212-2	Venting plug	AISI 316L (EN 1.4404)			
219	Counter flange	AISI 304 (EN 1.4301)	AISI 316 (EN 1.4401)		
245	Coupling guard	AISI 304 (EN 1.4301)			
273-1	Plug Washer	AISI 304 (EN 1.4301)	AISI 316 (EN 1.4401)		
615	Flange	Nodular Cast Iron			

**PART QUANTITY FOR MODEL
EVMSU(L)5**

Pump Type	N°																																	
	4	5-1	5-2	5-3	5-4	6	7	21	31***	32-1	43-2	43-3	43-4	43-5	44-1	45**	46	47	48	51	52-1	75	75-1	107	111	111-3	111-4	111-5	115-1	115-3*	115-4	115-5		
EVMSU(L)5 2	1	1	/	1	1	1	1	2	1	1	1	1	1	/	1	4	2	1	1	/	1	1	2	2	1	1	1	1	1	2	2	1	1	
EVMSU(L)5 3	1	1	1	1	1	1	1	3	1	1	3	1	1	1	1	4	2	1	1	/	1	1	2	3	1	1	1	1	1	2	2	1	1	
EVMSU(L)5 4	1	1	2	1	1	1	1	4	1	1	5	1	1	1	/	1	4	2	1	1	/	1	1	2	4	1	1	1	1	2	2	1	1	
EVMSU(L)5 5	1	1	3	1	1	1	1	5	1	1	7	1	1	1	/	1	4	2	1	1	/	1	1	2	5	1	1	1	1	2	2	1	1	
EVMSU(L)5 6	1	1	4	1	1	1	1	6	1	1	9	1	1	1	1	4	2	1	1	/	1	1	2	6	1	1	1	1	1	2	2	1	1	
EVMSU(L)5 7	1	1	5	1	1	1	1	7	1	1	11	1	1	1	/	1	4	2	1	1	/	1	1	2	7	1	1	1	1	2	2	1	1	
EVMSU(L)5 8	1	1	6	1	1	1	1	8	1	1	13	1	1	1	/	1	4	2	1	1	/	1	1	2	8	1	1	1	1	2	2	1	1	
EVMSU(L)5 9	1	1	7	1	1	1	1	9	1	1	15	1	1	1	1	4	2	1	1	/	1	1	2	9	1	1	1	1	1	2	2	1	1	
EVMSU(L)5 10	1	1	8	1	1	1	1	10	1	1	17	1	1	1	/	1	4	2	1	1	/	1	1	2	10	1	1	1	1	1	2	2	1	1
EVMSU(L)5 11	1	1	8	2	1	1	1	11	1	1	17	2	2	/	2	4	2	1	1	/	2	1	2	11	1	1	1	1	2	2	1	1		
EVMSU(L)5 12	1	1	9	2	1	1	1	12	1	1	19	2	2	1	2	4	2	1	1	1	2	1	2	12	1	1	1	1	2	2	1	1		
EVMSU(L)5 13	1	1	10	2	1	1	1	13	1	1	21	2	2	/	2	4	2	1	1	1	2	1	2	13	1	1	1	1	2	/	1	1		
EVMSU(L)5 14	1	1	11	2	1	1	1	14	1	1	23	2	2	/	2	4	2	1	1	1	2	1	2	14	1	1	1	1	2	/	1	1		
EVMSU(L)5 15	1	1	12	2	1	1	1	15	1	1	25	2	2	1	2	4	2	1	1	1	2	1	2	15	1	1	1	1	2	/	1	1		
EVMSU(L)5 16	1	1	13	2	1	1	1	16	1	1	27	2	2	/	2	4	2	1	1	1	2	1	2	16	1	1	1	1	2	/	1	1		
EVMSU(L)5 17	1	1	14	2	1	1	1	17	1	1	29	2	2	/	2	4	2	1	1	1	2	1	2	17	1	1	1	1	2	/	1	1		
EVMSU(L)5 19	1	1	16	2	1	1	1	19	1	1	33	2	2	/	2	4	2	1	1	1	2	1	2	19	1	1	1	1	2	/	1	1		

Pump Type	N°																						
	120-1	120-3	120-6	120-11*	128-1	128-5	128-6	130-1	130-2	131-1	135-1	135-6	137-1	140	160	162	212	212-1	212-2	219*	245	273-1	615**
EVMSU(L)5 2	4	4	4	4	4	4	4	3	4	1	4	4	1	2	1	1	1	2	1	2	2	2	2
EVMSU(L)5 3	4	4	4	4	4	4	4	3	4	1	4	4	1	2	1	1	1	2	1	2	2	2	2
EVMSU(L)5 4	4	4	4	4	4	4	4	3	4	1	4	4	1	2	1	1	1	2	1	2	2	2	2
EVMSU(L)5 5	4	4	4	4	4	4	4	3	4	1	4	4	1	2	1	1	1	2	1	2	2	2	2
EVMSU(L)5 6	4	4	4	4	4	4	4	3	4	1	4	4	1	2	1	1	1	2	1	2	2	2	2
EVMSU(L)5 7	4	4	4	4	4	4	4	3	4	1	4	4	1	2	1	1	1	2	1	2	2	2	2
EVMSU(L)5 8	4	4	4	4	4	4	4	3	4	1	4	4	1	2	1	1	1	2	1	2	2	2	2
EVMSU(L)5 9	4	4	4	4	4	4	4	3	4	1	4	4	1	2	1	1	1	2	1	2	2	2	2
EVMSU(L)5 10	4	4	4	4	4	4	4	3	4	1	4	4	1	2	1	1	1	2	1	2	2	2	2
EVMSU(L)5 11	4	4	4	4	4	4	4	3	4	1	4	4	1	2	1	1	1	2	1	2	2	2	2
EVMSU(L)5 12	4	4	4	4	4	4	4	3	4	1	4	4	1	2	1	1	1	2	1	2	2	2	2
EVMSU(L)5 13	4	4	4	/	4	4	4	3	4	1	4	4	1	2	1	1	1	2	1	/	2	2	2
EVMSU(L)5 14	4	4	4	/	4	4	4	3	4	1	4	4	1	2	1	1	1	2	1	/	2	2	2
EVMSU(L)5 15	4	4	4	/	4	4	4	3	4	1	4	4	1	2	1	1	1	2	1	/	2	2	2
EVMSU(L)5 16	4	4	4	/	4	4	4	3	4	1	4	4	1	2	1	1	1	2	1	/	2	2	2
EVMSU(L)5 17	4	4	4	/	4	4	4	3	4	1	4	4	1	2	1	1	1	2	1	/	2	2	2
EVMSU(L)5 19	4	4	4	/	4	4	4	3	4	1	4	4	1	2	1	1	1	2	1	/	2	2	2

* only for Oval flange (N)

** only for Loose round flange (L)

*** ■ shaft in AISI 329A (EN 1.4462)

SECTIONAL VIEW
EVMSU(L)10

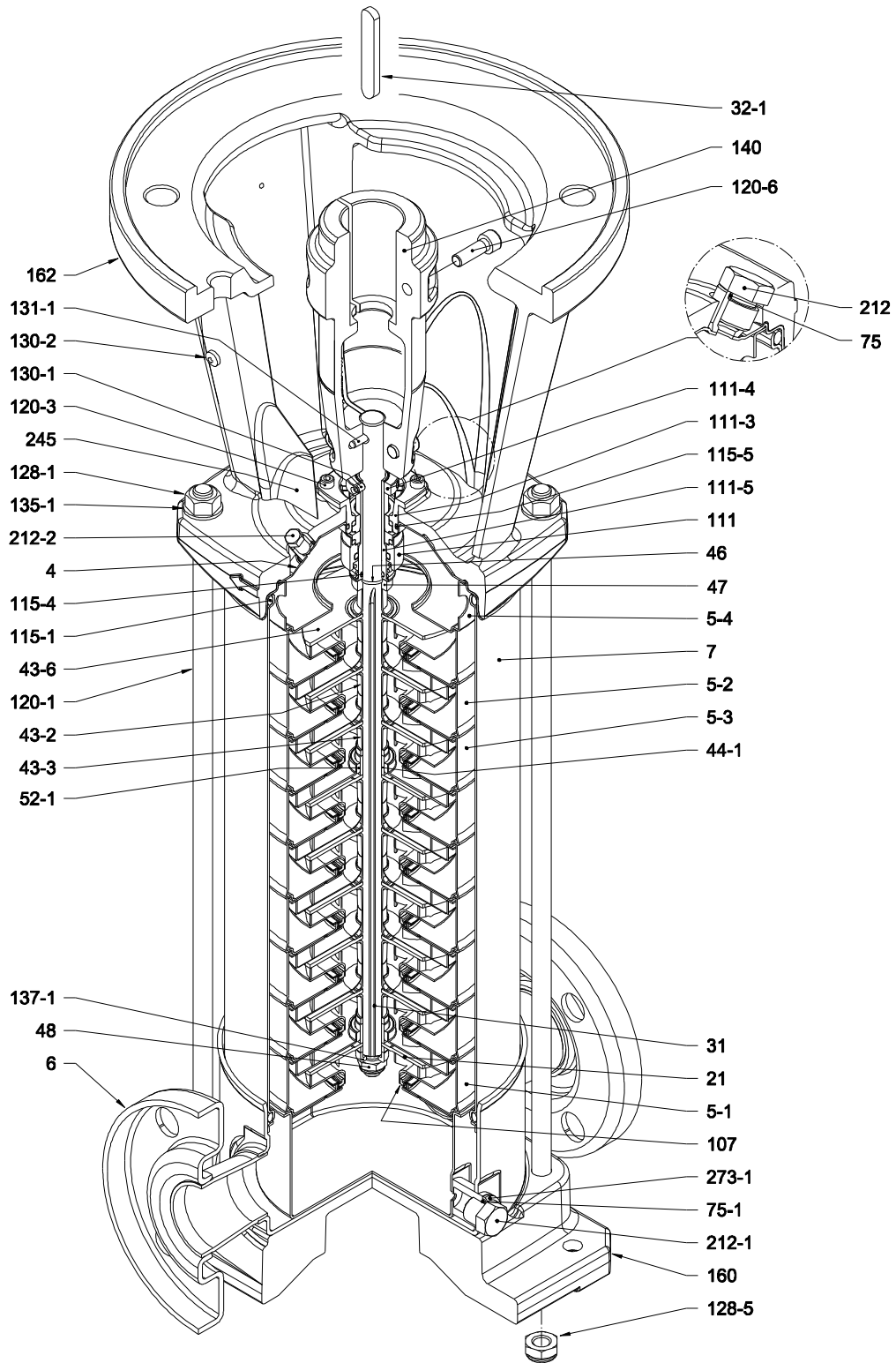

with Round (ANSI Compatible) flange (F)

PIPE CONNECTION

EVMSU(L)10

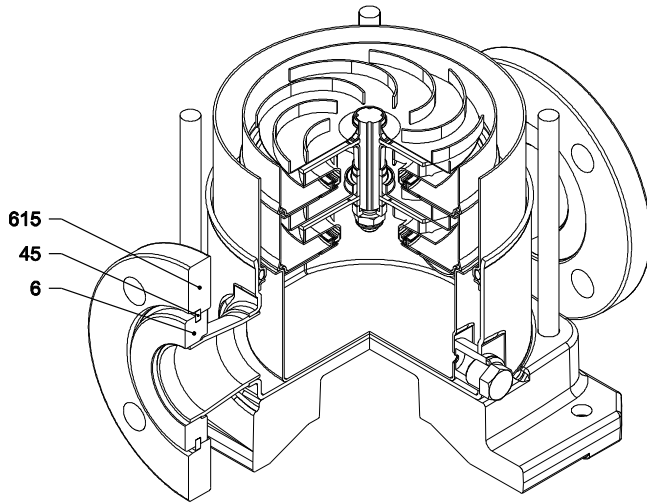

with Loose round ANSI compatible flange (L)

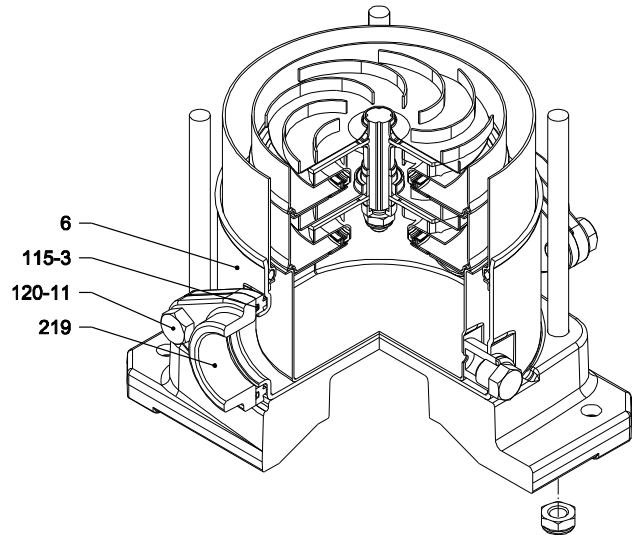

with Oval flange (N)

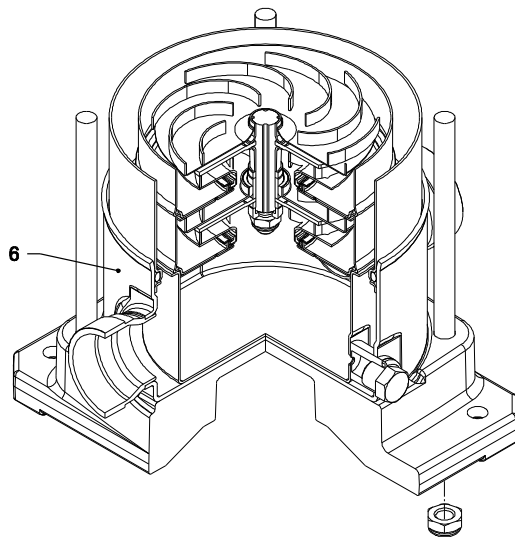

with victaulic connection (V)

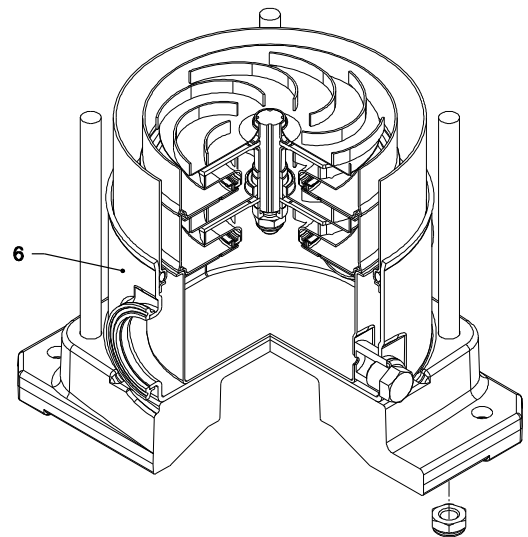

with Clamp connection (C)

SECTIONAL VIEW PART REFERENCE
EVMSU(L)10

N°	PART NAME	MATERIAL		DIMENSIONS [mm]	STANDARD
		EVMSU	EVMSUL		
4	Casing cover	AISI 304 (EN 1.4301)	AISI 316 (EN 1.4401)		
5-1	Suction casing	AISI 304 (EN 1.4301)	AISI 316 (EN 1.4401)		
5-2	Intermediate Casing	AISI 304 (EN 1.4301)	AISI 316 (EN 1.4401)		
5-3	Intermediate casing bearing	AISI 304 (EN 1.4301)	AISI 316 (EN 1.4401)		
5-4	Discharge casing	AISI 304 (EN 1.4301)	AISI 316 (EN 1.4401)		
6	Bottom casing	AISI 304 (EN 1.4301)	AISI 316 (EN 1.4401)		
7	Outer casing	AISI 304 (EN 1.4301)	AISI 316L (EN 1.4404)		
21	Impeller	AISI 304 (EN 1.4301)	AISI 316 (EN 1.4401)		
31	Shaft	AISI 304 (EN 1.4301)	AISI 316L (EN 1.4404)		
32-1	Adjuster Key	AISI 304 (EN 1.4301)			
43-2	Shaft sleeve (intermediate)	AISI 304 (EN 1.4301)	AISI 316L (EN 1.4404)		
43-3	Shaft sleeve (bearing)	AISI 304 (EN 1.4301)	AISI 316 (EN 1.4401)		
43-6	Washer	AISI 316L (EN 1.4404)		D. 26x1.2	
44-1	Shaft sleeve bearing	Tungsten carbide			
45	Flange holder	AISI 304 (EN 1.4301)			
46	Ring (mechanical seal)	AISI 316L (EN 1.4404)			
47	Ring Holder	AISI 304 (EN 1.4301)	AISI 316 (EN 1.4401)		
48	Impeller nut	A2-70 UNI 7323 with inox insert	A4-70 UNI 7323 with inox insert	M10	
52-1	Bearing	Tungsten carbide			
75	O-Ring (plug)	FPM		D. 12.37x2.62	OR 3050
75-1	O-Ring (plug)	FPM			
107	Liner ring	AISI 304 (EN 1.4301) + PPS	AISI 316 (EN 1.4401) + PPS		
111	Mechanical Seal	SiC/Carbon/FPM			
111-3	Mechanical seal seat	AISI 304 (EN 1.4301)	AISI 316 (EN 1.4401)		
111-4	Seal holder	AISI 304 (EN 1.4301)			
111-5	Mechanical seal cartridge	AISI 304 (EN 1.4301)	AISI 316 (EN 1.4401)		
115-1	O-Ring (outer casing)	FPM		D. 164,46x5,34	OR 6645
115-3	O-Ring	FPM			
115-4	O-Ring (cartridge sleeve)	FPM		D. 15,88x2,62	OR 121
115-5	O-Ring (seal cover)	FPM		D. 37.77x2.62	OR 3150
120-1	Tie-rod	Galvanized steel 6.8 strength class ISO 898/1		M12	
120-3	Screw	A2-70 UNI 7323		M5x12	ISO 4762
120-6	Screw for coupling	up to 5 HP from 7.5 HP to 11 HP above 15 HP	Galvanized steel	M6x25	ISO 4762
				M8x20	ISO 4762
				M10x30	ISO 4762
120-11	Screw for counterflange	A2-70 UNI 7323			
128-1	Nut for tie rod	Galvanized steel		M12	UNI 5588
128-5	Nut for tie rod	Galvanized steel		M12	UNI 7474
130-1	Set screw	A2-70 UNI 7323		M5x8	UNI 5923
130-2	Screw for coupling guard	A2-70 UNI 7323		M5x6	UNI 7687
131-1	Pin for shaft	Carbon Steel		D. 5x35	UNI 4838
135-1	Washer	Galvanized steel		D. 13x24x2,5	UNI 6592
137-1	Impeller spacer	AISI 304 (EN 1.4301)	AISI 316 (EN 1.4401)		
140	Coupling	up to 5 HP above 7.5 HP	Die cast Aluminium EN AB-AISI11Cu2 (Fe)		
			Cast iron		
160	Base	Die cast Aluminium EN AB-AISI11Cu2 (Fe)			
162	Motor bracket	Cast iron EN-GJL-200-EN 1561			
212	Plug	AISI 304 (EN 1.4301)	AISI 316 (EN 1.4401)	G 3/8 (BSPP)	
212-1	Plug	AISI 304 (EN 1.4301)	AISI 316 (EN 1.4401)	G 3/8 (BSPP)	
212-2	Venting plug	AISI 316L (EN 1.4404)			
219	Counter flange	AISI 304 (EN 1.4301)	AISI 316 (EN 1.4401)		
245	Coupling guard	AISI 304 (EN 1.4301)			
273-1	Plug Washer	AISI 304 (EN 1.4301)	AISI 316 (EN 1.4401)		
615	Flange	Nodular Cast Iron			

PART QUANTITY FOR MODEL
EVMSU(L)10

Pump Type	N°																														
	4	5-1	5-2	5-3	5-4	6	7	21	31	32-1	43-2	43-3	43-6	44-1	45**	46	47	48	52-1	75	75-1	107	111	111-3	111-4	111-5	115-1	115-3*	115-4	115-5	
EVMSU(L)10 1	1	1	/	1	1	1	1	1	1	1	/	1	1	1	4	2	1	1	1	1	2	1	1	1	1	1	1	2	2	1	1
EVMSU(L)10 2	1	1	/	1	1	1	1	2	1	1	1	1	/	1	4	2	1	1	1	1	2	2	1	1	1	1	1	2	2	1	1
EVMSU(L)10 3	1	1	1	1	1	1	1	3	1	1	3	1	/	1	4	2	1	1	1	1	2	3	1	1	1	1	1	2	2	1	1
EVMSU(L)10 4	1	1	2	1	1	1	1	4	1	1	5	1	/	1	4	2	1	1	1	1	2	4	1	1	1	1	1	2	2	1	1
EVMSU(L)10 5	1	1	3	1	1	1	1	5	1	1	7	1	/	1	4	2	1	1	1	1	2	5	1	1	1	1	1	2	2	1	1
EVMSU(L)10 6	1	1	4	1	1	1	1	6	1	1	9	1	/	1	4	2	1	1	1	1	2	6	1	1	1	1	1	2	2	1	1
EVMSU(L)10 7	1	1	5	1	1	1	1	7	1	1	11	1	/	1	4	2	1	1	1	1	2	7	1	1	1	1	1	2	2	1	1
EVMSU(L)10 8	1	1	5	2	1	1	1	8	1	1	11	2	/	2	4	2	1	1	2	1	2	8	1	1	1	1	1	2	2	1	1
EVMSU(L)10 9	1	1	6	2	1	1	1	9	1	1	13	2	/	2	4	2	1	1	2	1	2	9	1	1	1	1	1	2	2	1	1
EVMSU(L)10 10	1	1	7	2	1	1	1	10	1	1	15	2	/	2	4	2	1	1	2	1	2	10	1	1	1	1	1	2	2	1	1
EVMSU(L)10 11	1	1	8	2	1	1	1	11	1	1	17	2	/	2	4	2	1	1	2	1	2	11	1	1	1	1	1	2	/	1	1
EVMSU(L)10 12	1	1	9	2	1	1	1	12	1	1	19	2	/	2	4	2	1	1	2	1	2	12	1	1	1	1	1	2	/	1	1
EVMSU(L)10 14	1	1	11	2	1	1	1	14	1	1	23	2	/	2	4	2	1	1	2	1	2	14	1	1	1	1	1	2	/	1	1
EVMSU(L)10 15	1	1	12	2	1	1	1	15	1	1	25	2	/	2	4	2	1	1	2	1	2	15	1	1	1	1	1	2	/	1	1
EVMSU(L)10 16	1	1	13	2	1	1	1	16	1	1	27	2	/	2	4	2	1	1	2	1	2	16	1	1	1	1	1	2	/	1	1

Pump Type	N°																				
	120-1	120-3	120-6	120-11*	128-1	128-5	130-1	130-2	131-1	135-1	137-1	140	160	162	212	212-1	212-2	219*	245	273-1	615**
EVMSU(L)10 1	4	4	4	4	4	4	3	4	1	4	1	2	1	1	1	2	1	2	2	2	2
EVMSU(L)10 2	4	4	4	4	4	4	3	4	1	4	1	2	1	1	1	2	1	2	2	2	2
EVMSU(L)10 3	4	4	4	4	4	4	3	4	1	4	1	2	1	1	1	2	1	2	2	2	2
EVMSU(L)10 4	4	4	4	4	4	4	3	4	1	4	1	2	1	1	1	2	1	2	2	2	2
EVMSU(L)10 5	4	4	4	4	4	4	3	4	1	4	1	2	1	1	1	2	1	2	2	2	2
EVMSU(L)10 6	4	4	4	4	4	4	3	4	1	4	1	2	1	1	1	2	1	2	2	2	2
EVMSU(L)10 7	4	4	4	4	4	4	3	4	1	4	1	2	1	1	1	2	1	2	2	2	2
EVMSU(L)10 8	4	4	4	4	4	4	3	4	1	4	1	2	1	1	1	2	1	2	2	2	2
EVMSU(L)10 9	4	4	4	4	4	4	3	4	1	4	1	2	1	1	1	2	1	2	2	2	2
EVMSU(L)10 10	4	4	4	4	4	4	3	4	1	4	1	2	1	1	1	2	1	2	2	2	2
EVMSU(L)10 11	4	4	4	/	4	4	3	4	1	4	1	2	1	1	1	2	1	/	2	2	2
EVMSU(L)10 12	4	4	4	/	4	4	3	4	1	4	1	2	1	1	1	2	1	/	2	2	2
EVMSU(L)10 14	4	4	4	/	4	4	3	4	1	4	1	2	1	1	1	2	1	/	2	2	2
EVMSU(L)10 15	4	4	4	/	4	4	3	4	1	4	1	2	1	1	1	2	1	/	2	2	2
EVMSU(L)10 16	4	4	4	/	4	4	3	4	1	4	1	2	1	1	1	2	1	/	2	2	2

* only for Oval flange (N)

** only for Loose round flange (L)

128-6 / 135-6 : with Aluminium coupling

SECTIONAL VIEW
EVMSU(L)15

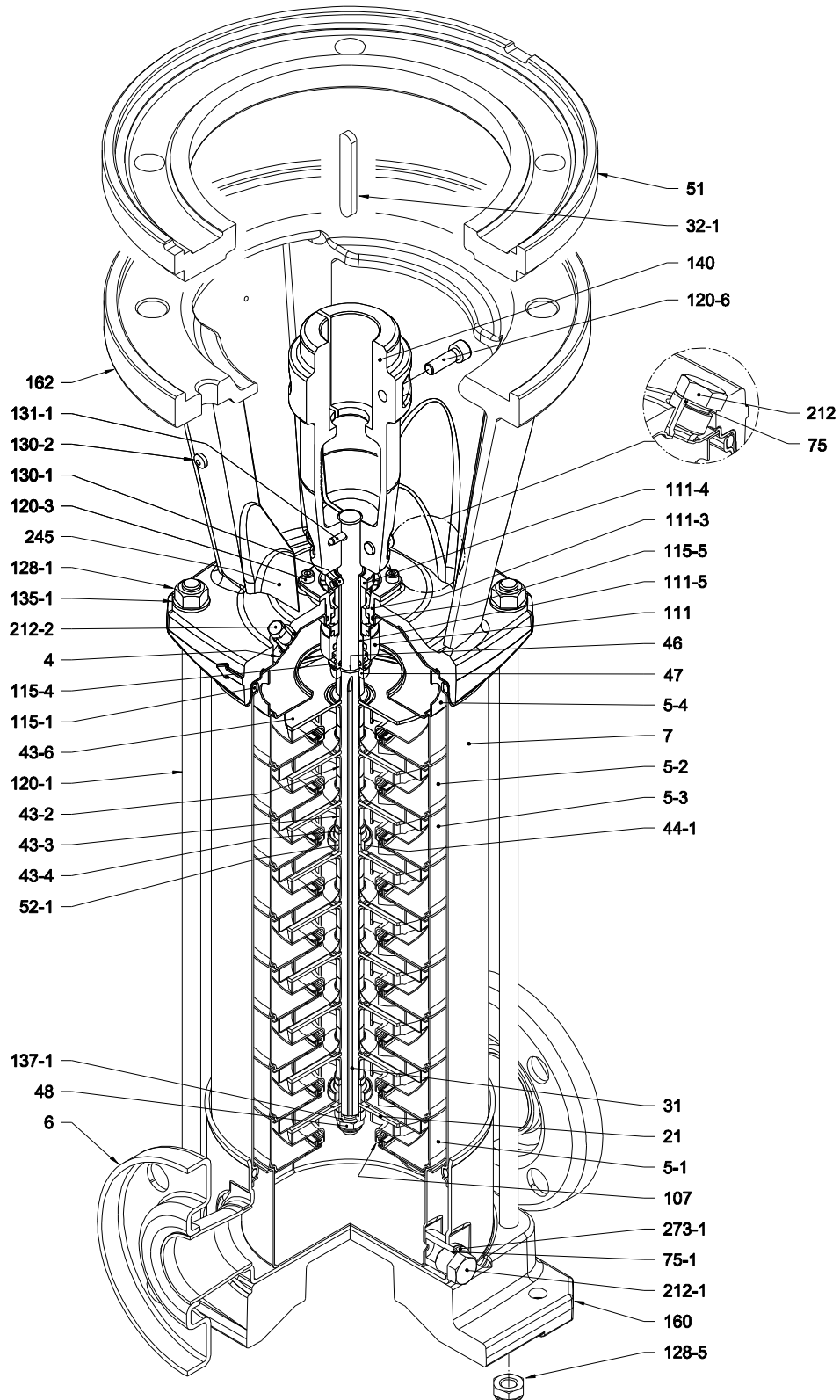

with Round (ANSI Compatible) flange (F)

PIPE CONNECTION

EVMSU(L)15

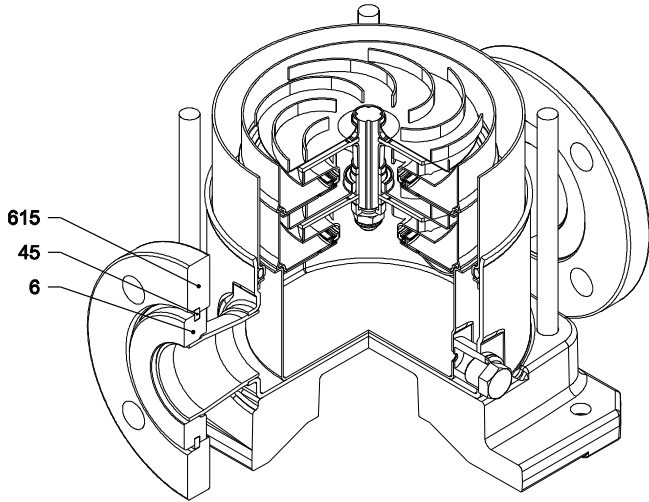

with Loose round ANSI compatible flange (L)

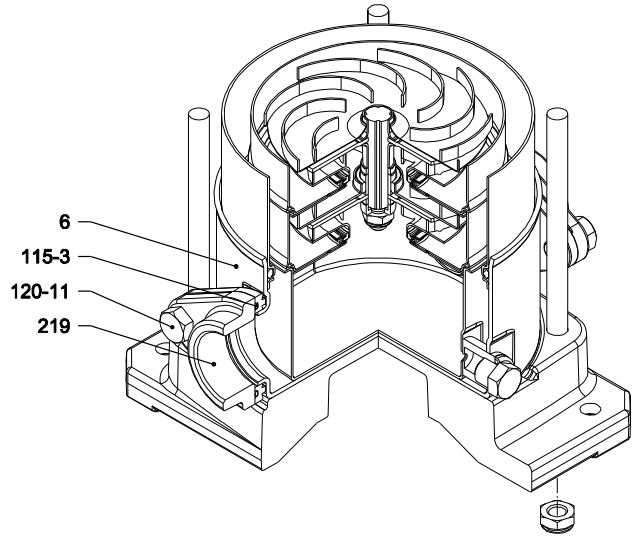

with Oval flange (N)

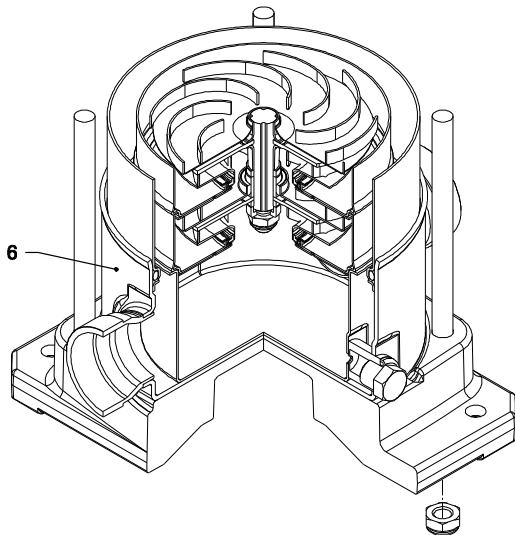

with victaulic connection (V)

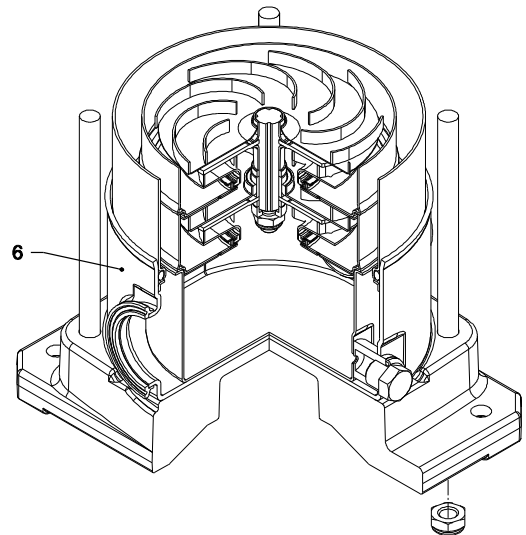

with Clamp connection (C)

SECTIONAL VIEW PART REFERENCE
EVMSU(L)15

N°	PART NAME	MATERIAL		DIMENSIONS [mm]	STANDARD
		EVMSU	EVMSUL		
4	Casing cover	AISI 304 (EN 1.4301)	AISI 316 (EN 1.4401)		
5-1	Suction casing	AISI 304 (EN 1.4301)	AISI 316 (EN 1.4401)		
5-2	Intermediate Casing	AISI 304 (EN 1.4301)	AISI 316 (EN 1.4401)		
5-3	Intermediate casing bearing	AISI 304 (EN 1.4301)	AISI 316 (EN 1.4401)		
5-4	Discharge casing	AISI 304 (EN 1.4301)	AISI 316 (EN 1.4401)		
6	Bottom casing	AISI 304 (EN 1.4301)	AISI 316 (EN 1.4401)		
7	Outer casing	AISI 304 (EN 1.4301)	AISI 316L (EN 1.4404)		
21	Impeller	AISI 304 (EN 1.4301)	AISI 316 (EN 1.4401)		
31	Shaft	AISI 304 (EN 1.4301) - AISI 329A (EN 1.4462)	AISI 316L (EN 1.4404) - AISI 329A (EN 1.4462)		
32-1	Adjuster Key	AISI 304 (EN 1.4301)			
43-2	Shaft sleeve (intermediate)	AISI 304 (EN 1.4301)	AISI 316L (EN 1.4404)		
43-3	Shaft sleeve (bearing)	AISI 304 (EN 1.4301)	AISI 316 (EN 1.4401)		
43-4	Shaft sleeve (adjustment)	AISI 304 (EN 1.4301)	AISI 316 (EN 1.4401)		
43-6	Washer	AISI 316L (EN 1.4404)		D. 26x1.2	
44-1	Shaft sleeve bearing	Tungsten carbide			
45	Flange holder	AISI 304 (EN 1.4301)			
46	Ring (mechanical seal)	AISI 316L (EN 1.4404)			
47	Ring Holder	AISI 304 (EN 1.4301)	AISI 316 (EN 1.4401)		
48	Impeller nut	A2-70 UNI 7323 with inox insert	A4-70 UNI 7323 with inox insert	M10	
51	Motor adapter	Cast iron EN-GJL-200-EN 1561			
52-1	Bearing	Tungsten carbide			
75	O-Ring (plug)	FPM		D. 12.37x2.62	OR 3050
75-1	O-Ring (plug)	FPM			
107	Liner ring	AISI 304 (EN 1.4301) + PPS	AISI 316 (EN 1.4401) + PPS		
111	Mechanical Seal	SiC/Carbon/FPM			
111-3	Mechanical seal seat	AISI 304 (EN 1.4301)	AISI 316 (EN 1.4401)		
111-4	Seal holder	AISI 304 (EN 1.4301)			
111-5	Mechanical seal cartridge	AISI 304 (EN 1.4301)	AISI 316 (EN 1.4401)		
115-1	O-Ring (outer casing)	FPM		D. 164.46x5.34	OR 6645
115-3	O-Ring	FPM			
115-4	O-Ring (cartridge sleeve)	FPM		D. 15.88x2.62	OR 121
115-5	O-Ring (seal cover)	FPM		D. 37.77x2.62	OR 3150
120-1	Tie-rod	Galvanized steel 6.8 strength class ISO 898/1		M12	
120-3	Screw	A2-70 UNI 7323		M5x12	ISO 4762
120-6	Screw for coupling	up to 5 HP from 7.5 HP to 11 HP above 15 HP	Galvanized steel	M6x25	ISO 4762
				M8x20	ISO 4762
				M10x30	ISO 4762
120-11	Screw for counterflange	A2-70 UNI 7323			
128-1	Nut for tie rod	Galvanized steel		M12	UNI 5588
128-5	Nut for tie rod	Galvanized steel		M12	UNI 7474
130-1	Set screw	A2-70 UNI 7323		M5x8	UNI 5923
130-2	Screw for coupling guard	A2-70 UNI 7323		M5x6	UNI 7687
131-1	Pin for shaft	Carbon Steel		D. 5x35	UNI 4838
135-1	Washer	Galvanized steel		D. 13x24x2.5	UNI 6592
137-1	Impeller spacer	AISI 304 (EN 1.4301)	AISI 316 (EN 1.4401)		
140	Coupling	Die cast Aluminium EN AB-AISI11Cu2 (Fe) Cast iron EN-GJL-200-EN 1561			
160	Base	Die cast Aluminium EN AB-AISI11Cu2 (Fe)			
162	Motor bracket	Cast iron EN-GJL-200-EN 1561			
212	Plug	AISI 304 (EN 1.4301)	AISI 316 (EN 1.4401)	G 3/8 (BSPP)	
212-1	Plug	AISI 304 (EN 1.4301)	AISI 316 (EN 1.4401)	G 3/8 (BSPP)	
212-2	Venting plug	AISI 316L (EN 1.4404)			
219	Counter flange	AISI 304 (EN 1.4301)	AISI 316 (EN 1.4401)		
245	Coupling guard	AISI 304 (EN 1.4301)			
273-1	Plug Washer	AISI 304 (EN 1.4301)	AISI 316 (EN 1.4401)		
615	Flange	Carbon steel			

**PART QUANTITY FOR MODEL
EVMSU(L)15**

Pump Type	N°																															
	4	5-1	5-2	5-3	5-4	6	7	21	31***	32-1	43-2	43-3	43-4	43-6	44-1	45**	46	47	48	51	52-1	75	75-1	107	111	111-3	111-4	111-5	115-1	115-3*	115-4	115-5
EVMSU(L)15 1	1	1	/	1	1	1	1	1	1	/	1	1	1	1	4	2	1	1	/	1	1	2	1	1	1	1	1	1	2	2	1	1
EVMSU(L)15 2	1	1	/	1	1	1	2	1	1	1	1	1	/	1	4	2	1	1	/	1	1	2	2	1	1	1	1	1	2	2	1	1
EVMSU(L)15 3	1	1	1	1	1	1	3	1	1	3	1	1	/	1	4	2	1	1	/	1	1	2	3	1	1	1	1	1	2	2	1	1
EVMSU(L)15 4	1	1	2	1	1	1	4	1	1	5	1	1	/	1	4	2	1	1	/	1	1	2	4	1	1	1	1	1	2	2	1	1
EVMSU(L)15 5	1	1	3	1	1	1	5	1	1	7	1	1	/	1	4	2	1	1	/	1	1	2	5	1	1	1	1	1	2	2	1	1
EVMSU(L)15 6	1	1	3	2	1	1	6	1	1	7	2	2	/	2	4	2	1	1	/	2	1	2	6	1	1	1	1	1	2	2	1	1
EVMSU(L)15 7	1	1	4	2	1	1	7	1	1	9	2	2	/	2	4	2	1	1	/	2	1	2	7	1	1	1	1	1	2	2	1	1
EVMSU(L)15 8	1	1	5	2	1	1	8	1	1	11	2	2	/	2	4	2	1	1	/	2	1	2	8	1	1	1	1	1	2	/	1	1
EVMSU(L)15 9	1	1	6	2	1	1	9	1	1	13	2	2	/	2	4	2	1	1	/	2	1	2	9	1	1	1	1	1	2	/	1	1
EVMSU(L)15 10	1	1	7	2	1	1	10	1	1	15	2	2	/	2	4	2	1	1	/	2	1	2	10	1	1	1	1	1	2	/	1	1
EVMSU(L)15 11	1	1	8	2	1	1	11	1	1	17	2	2	/	2	4	2	1	1	/	2	1	2	11	1	1	1	1	1	2	/	1	1
EVMSU(L)15 12	1	1	9	2	1	1	12	1	1	19	2	2	/	2	4	2	1	1	/	2	1	2	12	1	1	1	1	1	2	/	1	1

Pump Type	N°																				
	120-1	120-3	120-6	120-11*	128-1	128-5	130-1	130-2	131-1	135-1	137-1	140	160	162	212	212-1	212-2	219*	245	273-1	615**
EVMSU(L)15 1	4	4	4	4	4	4	3	4	1	4	1	2	1	1	1	2	1	2	2	2	2
EVMSU(L)15 2	4	4	4	4	4	4	3	4	1	4	1	2	1	1	1	2	1	2	2	2	2
EVMSU(L)15 3	4	4	4	4	4	4	3	4	1	4	1	2	1	1	1	2	1	2	2	2	2
EVMSU(L)15 4	4	4	4	4	4	4	3	4	1	4	1	2	1	1	1	2	1	2	2	2	2
EVMSU(L)15 5	4	4	4	4	4	4	3	4	1	4	1	2	1	1	1	2	1	2	2	2	2
EVMSU(L)15 6	4	4	4	4	4	4	3	4	1	4	1	2	1	1	1	2	1	2	2	2	2
EVMSU(L)15 7	4	4	4	4	4	4	3	4	1	4	1	2	1	1	1	2	1	2	2	2	2
EVMSU(L)15 8	4	4	4	/	4	4	3	4	1	4	1	2	1	1	1	2	1	/	2	2	2
EVMSU(L)15 9	4	4	4	/	4	4	3	4	1	4	1	2	1	1	1	2	1	/	2	2	2
EVMSU(L)15 10	4	4	4	/	4	4	3	4	1	4	1	2	1	1	1	2	1	/	2	2	2
EVMSU(L)15 11	4	4	4	/	4	4	3	4	1	4	1	2	1	1	1	2	1	/	2	2	2
EVMSU(L)15 12	4	4	4	/	4	4	3	4	1	4	1	2	1	1	1	2	1	/	2	2	2

- * only for Oval flange (N)
- ** only for Loose round flange (L)
- *** ■ shaft in AISI 329A (EN 1.4462)
- 128-6 / 135-6 : with Aluminium coupling

SECTIONAL VIEW
EVMSU(L)20

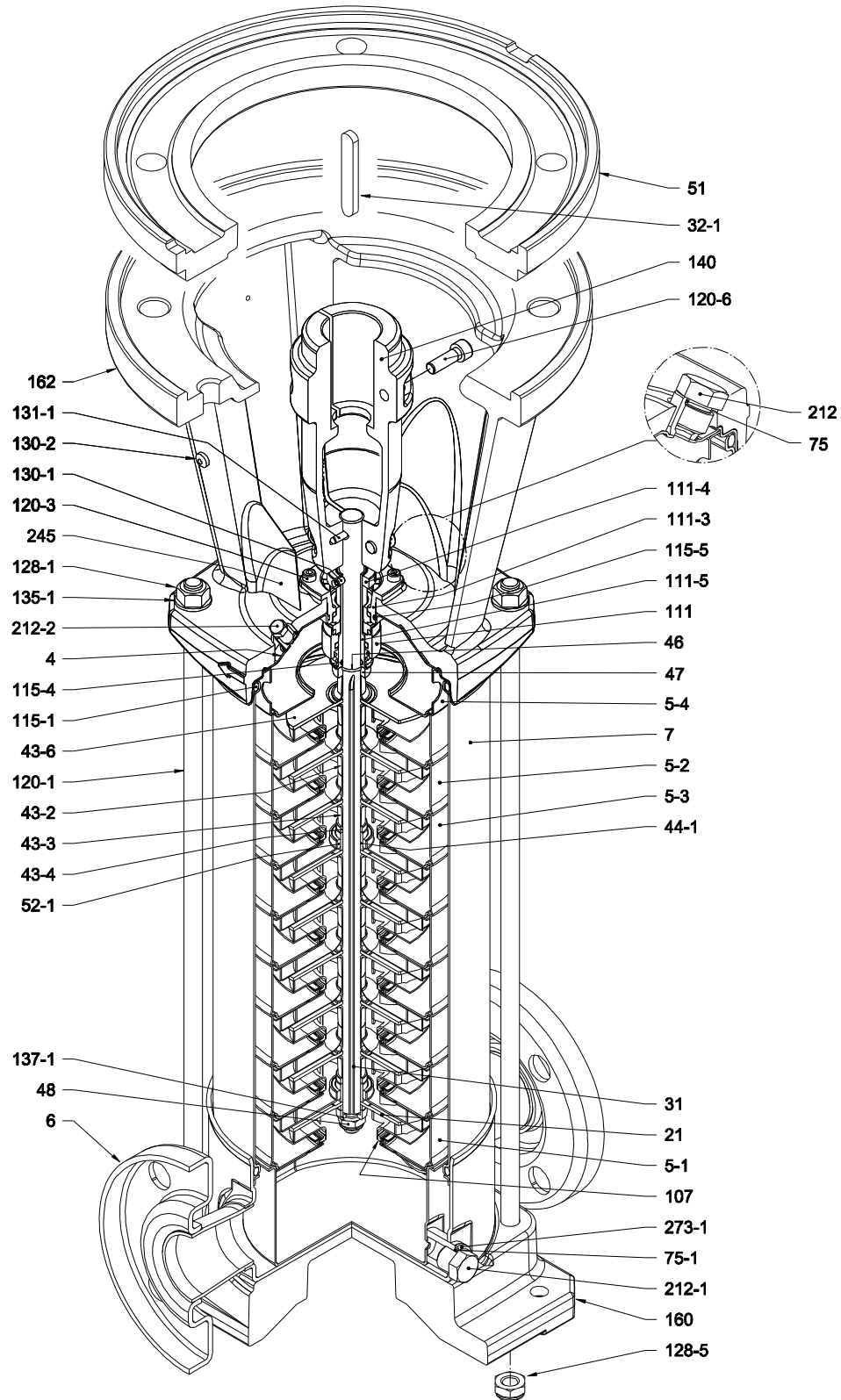

with Round (ANSI Compatible) flange (F)

PIPE CONNECTION

EVMSU(L)20

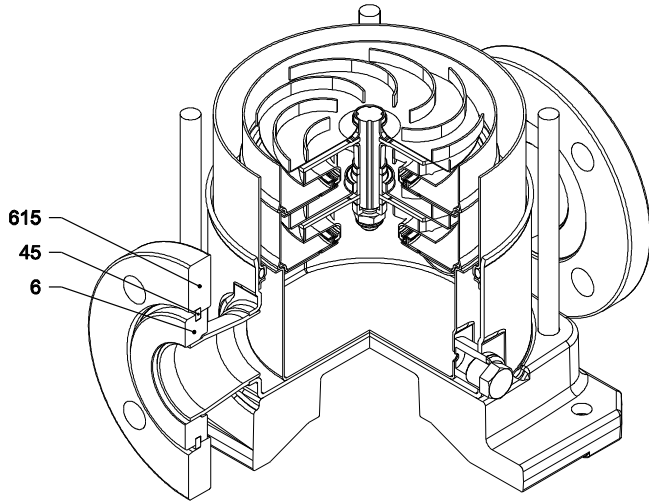

with Loose round ANSI compatible flange (L)

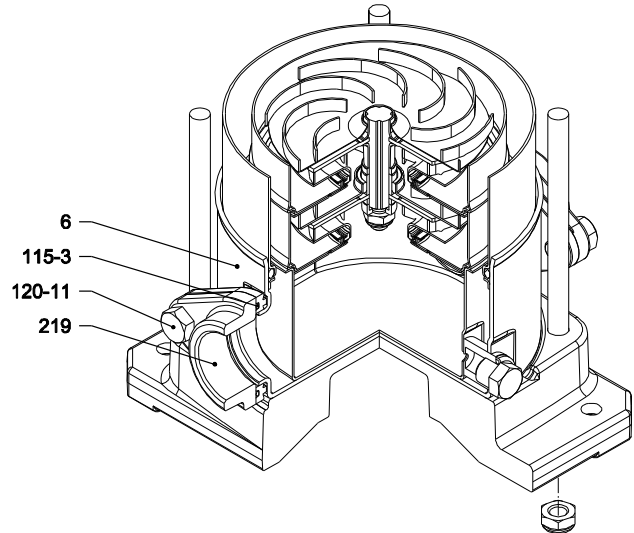

with Oval flange (N)

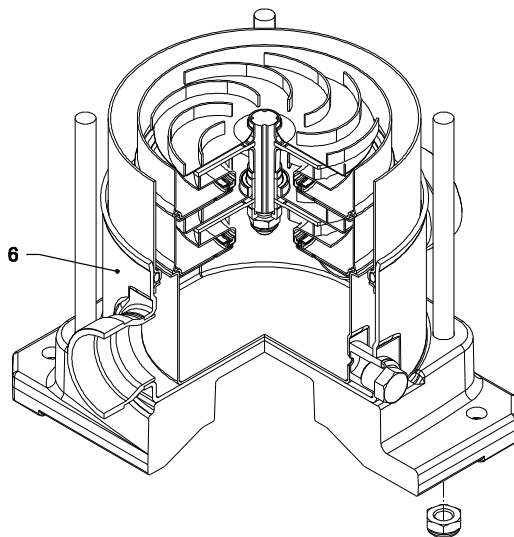

with victaulic connection (V)

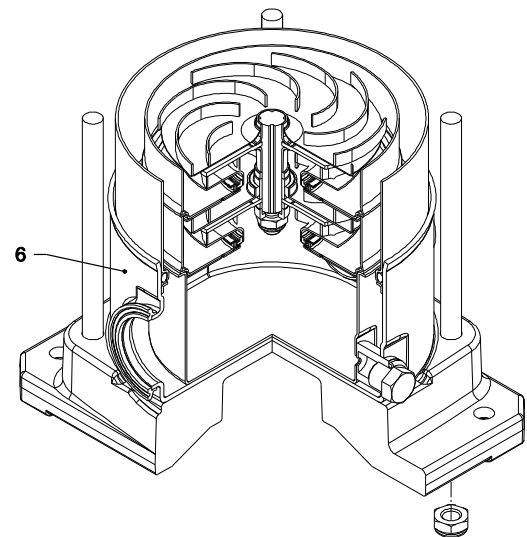

with Clamp connection (C)

SECTIONAL VIEW PART REFERENCE
EVMSU(L)20

N°	PART NAME	MATERIAL		DIMENSIONS [mm]	STANDARD
		EVMSU	EVMSUL		
4	Casing cover	AISI 304 (EN 1.4301)	AISI 316 (EN 1.4401)		
5-1	Suction casing	AISI 304 (EN 1.4301)	AISI 316 (EN 1.4401)		
5-2	Intermediate Casing	AISI 304 (EN 1.4301)	AISI 316 (EN 1.4401)		
5-3	Intermediate casing bearing	AISI 304 (EN 1.4301)	AISI 316 (EN 1.4401)		
5-4	Discharge casing	AISI 304 (EN 1.4301)	AISI 316 (EN 1.4401)		
6	Bottom casing	AISI 304 (EN 1.4301)	AISI 316 (EN 1.4401)		
7	Outer casing	AISI 304 (EN 1.4301)	AISI 316L (EN 1.4404)		
21	Impeller	AISI 304 (EN 1.4301)	AISI 316 (EN 1.4401)		
31	Shaft	AISI 304 (EN 1.4301) - AISI 329A (EN 1.4462)	AISI 316L (EN 1.4404) - AISI 329A (EN 1.4462)		
32-1	Adjuster Key	AISI 304 (EN 1.4301)			
43-2	Shaft sleeve (intermediate)	AISI 304 (EN 1.4301)	AISI 316L (EN 1.4404)		
43-3	Shaft sleeve (bearing)	AISI 304 (EN 1.4301)	AISI 316 (EN 1.4401)		
43-4	Shaft sleeve (adjustment)	AISI 304 (EN 1.4301)	AISI 316 (EN 1.4401)		
43-6	Washer	AISI 316L (EN 1.4404)		D. 26x1.2	
44-1	Shaft sleeve bearing	Tungsten carbide			
45	Flange holder	AISI 304 (EN 1.4301)			
46	Ring (mechanical seal)	AISI 316L (EN 1.4404)			
47	Ring Holder	AISI 304 (EN 1.4301)	AISI 316 (EN 1.4401)		
48	Impeller nut	A2-70 UNI 7323 with inox insert	A4-70 UNI 7323 with inox insert	M10	
51	Motor adapter	Cast iron EN-GJL-200-EN 1561			
52-1	Bearing	Tungsten carbide			
75	O-Ring (plug)	FPM		D. 12.37x2.62	OR 3050
75-1	O-Ring (plug)	FPM			
107	Liner ring	AISI 304 (EN 1.4301) + PPS	AISI 316 (EN 1.4401) + PPS		
111	Mechanical Seal	SiC/Carbon/FPM			
111-3	Mechanical seal seat	AISI 304 (EN 1.4301)	AISI 316 (EN 1.4401)		
111-4	Seal holder	AISI 304 (EN 1.4301)			
111-5	Mechanical seal cartridge	AISI 304 (EN 1.4301)	AISI 316 (EN 1.4401)		
115-1	O-Ring (outer casing)	FPM		D. 164.46x5.34	OR 6645
115-3	O-Ring	FPM			
115-4	O-Ring (cartridge sleeve)	FPM		D. 15.88x2.62	OR 121
115-5	O-Ring (seal cover)	FPM		D. 37.77x2.62	OR 3150
120-1	Tie-rod	Galvanized steel 6.8 strength class ISO 898/1		M12	
120-3	Screw	A2-70 UNI 7323		M5x12	ISO 4762
120-6	Screw for coupling	up to 5 HP from 7.5 HP to 11 HP above 15 HP	Galvanized steel	M6x25	ISO 4762
				M8x20	ISO 4762
				M10x30	ISO 4762
120-11	Screw for counterflange	A2-70 UNI 7323			
128-1	Nut for tie rod	Galvanized steel		M12	UNI 5588
128-5	Nut for tie rod	Galvanized steel		M12	UNI 7474
130-1	Set screw	A2-70 UNI 7323		M5x8	UNI 5923
130-2	Screw for coupling guard	A2-70 UNI 7323		M5x6	UNI 7687
131-1	Pin for shaft	Carbon Steel		D. 5x35	UNI 4838
135-1	Washer	Galvanized steel		D. 13x24x2.5	UNI 6592
137-1	Impeller spacer	AISI 304 (EN 1.4301)	AISI 316 (EN 1.4401)		
140	Coupling	up to 5 HP above 7.5 HP	Die cast Aluminium EN AB-AISI11Cu2 (Fe) Cast iron EN-GJL-200-EN 1561		
160	Base	Die cast Aluminium EN AB-AISI11Cu2 (Fe)			
162	Motor bracket	Cast iron EN-GJL-200-EN 1561			
212	Plug	AISI 304 (EN 1.4301)	AISI 316 (EN 1.4401)	G 3/8 (BSPP)	
212-1	Plug	AISI 304 (EN 1.4301)	AISI 316 (EN 1.4401)	G 3/8 (BSPP)	
212-2	Venting plug	AISI 316L (EN 1.4404)			
219	Counter flange	AISI 304 (EN 1.4301)	AISI 316 (EN 1.4401)		
245	Coupling guard	AISI 304 (EN 1.4301)			
273-1	Plug Washer	AISI 304 (EN 1.4301)	AISI 316 (EN 1.4401)		
615	Flange	Carbon steel			

PART QUANTITY FOR MODEL
EVMSU(L)20

Pump Type	N°																																
	4	5-1	5-2	5-3	5-4	6	7	21	31***	32-1	43-2	43-3	43-4	43-6	44-1	45**	46	47	48	51	52-1	75	75-1	107	111	111-3	111-4	111-5	115-1	115-3*	115-4	115-5	
EVMSU(L)20 1	1	1	/	1	1	1	1	1	1	1	/	1	1	1	1	4	2	1	1	/	1	1	2	1	1	1	1	1	1	2	2	1	1
EVMSU(L)20 2	1	1	/	1	1	1	1	2	1	1	1	1	1	/	1	4	2	1	1	/	1	1	2	2	1	1	1	1	1	2	2	1	1
EVMSU(L)20 3	1	1	1	1	1	1	1	3	1	1	3	1	1	/	1	4	2	1	1	/	1	1	2	3	1	1	1	1	1	2	2	1	1
EVMSU(L)20 4	1	1	2	1	1	1	1	4	1	1	5	1	1	/	1	4	2	1	1	/	1	1	2	4	1	1	1	1	1	2	2	1	1
EVMSU(L)20 5	1	1	2	2	1	1	1	5	1	1	5	2	2	/	2	4	2	1	1	/	2	1	2	5	1	1	1	1	2	2	1	1	
EVMSU(L)20 6	1	1	3	2	1	1	1	6	1	1	7	2	2	/	2	4	2	1	1	/	2	1	2	6	1	1	1	1	2	2	1	1	
EVMSU(L)20 7	1	1	4	2	1	1	1	7	1	1	9	2	2	/	2	4	2	1	1	1	2	1	2	7	1	1	1	1	2	/	1	1	
EVMSU(L)20 8	1	1	5	2	1	1	1	8	1	1	11	2	2	/	2	4	2	1	1	1	2	1	2	8	1	1	1	1	2	/	1	1	
EVMSU(L)20 9	1	1	6	2	1	1	1	9	1	1	13	2	2	/	2	4	2	1	1	1	2	1	2	9	1	1	1	1	2	/	1	1	
EVMSU(L)20 10	1	1	7	2	1	1	1	10	1	1	15	2	2	/	2	4	2	1	1	1	2	1	2	10	1	1	1	1	2	/	1	1	

Pump Type	N°																				
	120-1	120-3	120-6	120-11*	128-1	128-5	130-1	130-2	131-1	135-1	137-1	140	160	162	212	212-1	212-2	219*	245	273-1	615**
EVMSU(L)20 1	4	4	4	4	4	4	3	4	1	4	1	2	1	1	1	2	1	2	2	2	2
EVMSU(L)20 2	4	4	4	4	4	4	3	4	1	4	1	2	1	1	1	2	1	2	2	2	2
EVMSU(L)20 3	4	4	4	4	4	4	3	4	1	4	1	2	1	1	1	2	1	2	2	2	2
EVMSU(L)20 4	4	4	4	4	4	4	3	4	1	4	1	2	1	1	1	2	1	2	2	2	2
EVMSU(L)20 5	4	4	4	4	4	4	3	4	1	4	1	2	1	1	1	2	1	2	2	2	2
EVMSU(L)20 6	4	4	4	4	4	4	3	4	1	4	1	2	1	1	1	2	1	2	2	2	2
EVMSU(L)20 7	4	4	4	/	4	4	3	4	1	4	1	2	1	1	1	2	1	/	2	2	2
EVMSU(L)20 8	4	4	4	/	4	4	3	4	1	4	1	2	1	1	1	2	1	/	2	2	2
EVMSU(L)20 9	4	4	4	/	4	4	3	4	1	4	1	2	1	1	1	2	1	/	2	2	2
EVMSU(L)20 10	4	4	4	/	4	4	3	4	1	4	1	2	1	1	1	2	1	/	2	2	2

* only for Oval flange (N)
 ** only for Loose round flange (L)
 *** ■ shaft in AISI 329A (EN 1.4462)
 128-6 / 135-6 : with Aluminium coupling

SECTIONAL VIEW

**MODEL EVMUG32
EVMUL32**

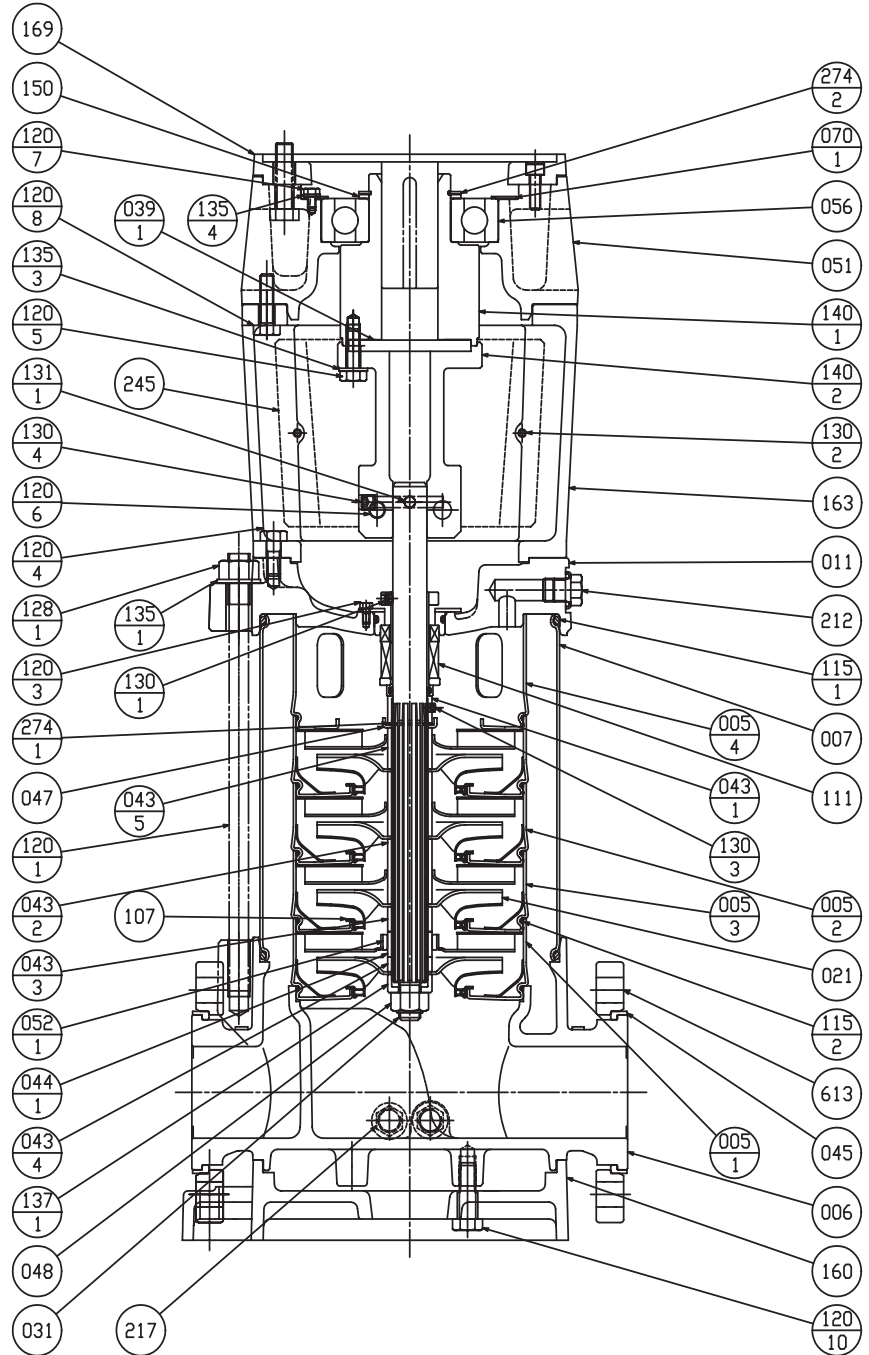
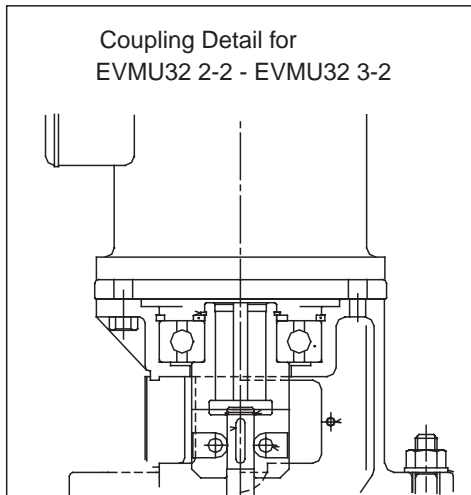
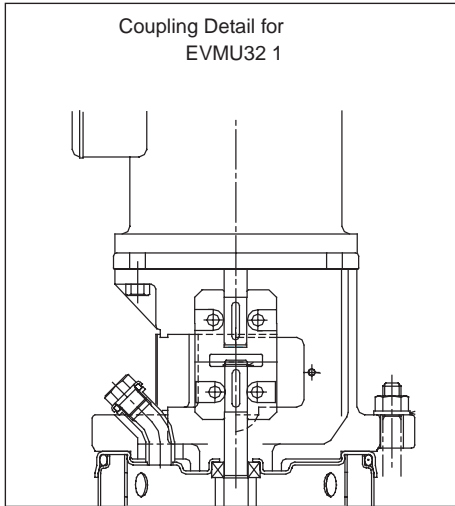

(For reference only. See pricing for part availability.)

SECTIONAL VIEW

**MODEL EVMUG32
EVMUL32**

NO.	PART NAME	MATERIAL	
		EVMUG	EVMUL
005-1	Stage casing (suction)	AISI304	AISI316
005-2	Stage casing	AISI304	AISI316
005-3	Stage casing (bearing)	AISI304	AISI316
005-4	Stage casing (Top)	AISI304	AISI316
006	Bottom casing	Cast iron EN-GJL-250	Cast AISI316 (G-X6CrNiMo18 0)
007	Outer sleeve	AISI304	AISI316
011	Casing cover	Cast iron EN-GJS-400-15	Cast iron EN-GJS-400-15+AISI304
021	Impeller	AISI304	AISI316
031	Shaft	AISI316	
039-1	Key (coupling)	C45	
043-1	Shaft sleeve (mechanical seal)	AISI304	AISI316
043-2	Shaft sleeve (stage)	AISI304	AISI316
043-3	Shaft sleeve (bearing/upper)	AISI304	AISI316
043-4	Shaft sleeve (bearing/lower)	AISI304	AISI316
043-5	Shaft sleeve (top)	AISI304	AISI316
044-1	Bearing sleeve (stage)	Tungsten carbide	
045	Adjusting ring	C40	
047	Split ring retainer	AISI304	AISI316
048	Friction nut	AISI304	AISI316
051	Bearing housing	Cast iron EN-GJL-200	
052-1	Bearing (stage)	Tungsten carbide	
056	Ball bearing	-	
070-1	Bearing holder	AISI304	
107	Wear ring	AISI316+PTFE	
111	Mechanical seal Cartridge ass'y	SiC/Carbon/FPM/316	
115-1	O-ring (outer)	FPM	
115-2	O-ring (stage)	FPM	
120-1	Tie-rod bolt	Zincate steel with 6.8 strength class ISO 898/1	
120-3	Bolt (mechanical seal)	Stainless steel A2-70 ISO3506	
120-4	Bolt (casing cover)	Stainless steel A2-70 ISO3506	
120-5	Bolt (coupling M-side)	Zincate steel with 8.8 strength class ISO 898/1	
120-6	Bolt (coupling P-side)	Zincate steel with 8.8 strength class ISO 898/1	
120-7	Bolt (bearing)	Zincate steel with 8.8 strength class ISO 898/1	
120-8	Bolt (bearing housing)	Zincate steel with 8.8 strength class ISO 898/1	
120-10	Bolt (base plate)	Zincate steel with 8.8 strength class ISO 898/1	
128-1	Nut (tie-rod bolt)	Zincate steel with 6S strength class ISO 898/2	
130-1	Screw (mechanical seal)	Stainless steel A2-70 ISO3506	
130-2	Screw (coupling guard)	Stainless steel A2-70 ISO3506	
130-3	Screw (mechanical seal)	Stainless steel A2-70 ISO3506	
130-4	Screw (coupling pin)	Strength class 45H ISO898/5	
131-1	Pin (shaft)	CF35SMnPb10	
135-1	Washer (tie-rod bolt)	Zincate steel	
135-3	Spring washer (coupling bolt M-side)	Zincate steel	
135-4	Spring washer (bearing)	Zincate steel	
137-1	Shaft end sleeve	AISI304	AISI316
140-1	Coupling upper half	Steel (36SMnPb14)	
140-2	Coupling lower half	Steel (36SMnPb14)	
150	Spacer (coupling)	C45	
160	Base plate	Cast iron EN-GJL-200	
163	Motor stool	Cast iron EN-GJL-200	
169	Motor liner	Cast iron EN-GJL-200	
212	Vent plug (with seal ring)	AISI304/FPM	AISI316/FPM
217	Plug (with seal ring)	AISI304/FPM	AISI316/FPM
245	Coupling guard	AISI304	
274-1	C-ring (top)	AISI304	AISI316
274-2	C-ring (coupling)	Carbon tool steel (TC80)	
613	Pump flange	C40	

(For reference only. See pricing for part availability.)

SECTIONAL VIEW

**MODEL EVMUG45
EVMUG64
EVMUL45
EVMUL64**

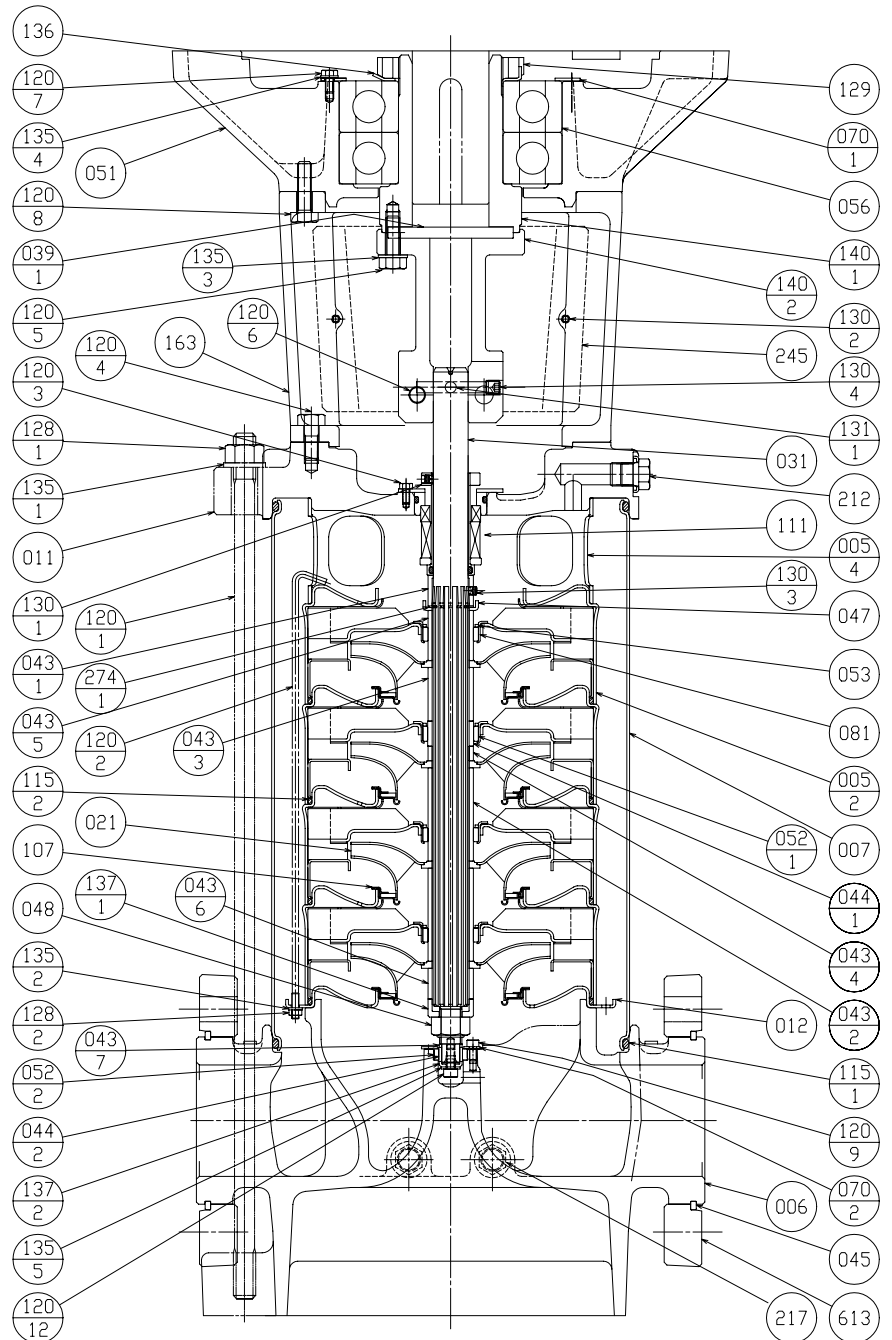
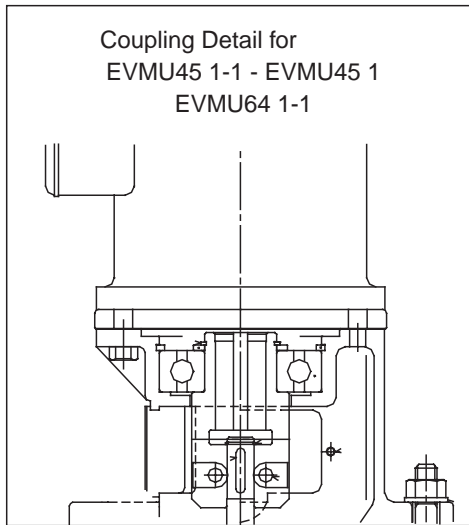

(For reference only. See pricing for part availability.)

SECTIONAL VIEW – PART REFERENCE

**Model EVMUG45 EVMUG64
EVMUL45 EVMUL64**

NO.	PART NAME	MATERIAL	
		EVMUG	EVMUL
005-2	Stage casing	AISI304	AISI316
005-4	Top casing	AISI304	AISI316
006	Bottom casing	16bar:Cast iron EN-GJL-250 25bar:Cast iron EN-GJS-400-15	Cast AISI316 (G-X6CrNiMo18 0)
007	Outer sleeve	AISI304	AISI316
011	Casing cover	Cast iron EN-GJS-400-15	Cast iron EN-GJS-400-15+AISI316
012	Suction cover	AISI304	AISI316
021	Impeller	AISI304	AISI316
031	Shaft	AISI316	
039-1	Key (coupling)	C45	
043-1	Shaft sleeve (mechanical seal)	AISI304	AISI316
043-2	Shaft sleeve (stage)	AISI304	AISI316
043-3	Shaft sleeve (bearing/upper)	AISI304	AISI316
043-4	Shaft sleeve (bearing/lower)	AISI304	AISI316
043-5	Shaft sleeve (top)	AISI304	AISI316
043-6	Shaft sleeve (suction)	AISI304	AISI316
043-7	Shaft sleeve (bottom bearing)	AISI304	AISI316
044-1	Bearing sleeve (stage)	Tungsten carbide	
044-2	Bearing sleeve (bottom bearing)	Tungsten carbide	
045	Adjusting ring	C40	
047	Split ring retainer	AISI304	AISI316
048	Friction nut	AISI304	AISI316
051	Bearing housing	Cast iron EN-GJL-200	
052-1	Bearing (stage)	Tungsten carbide	
052-2	Bearing (bottom)	Tungsten carbide	
053	Bush holder	AISI304	AISI316
056	Ball bearing	-	
070-1	Bearing holder	AISI304	
070-2	Bearing holder (bottom bearing)	AISI304	AISI316
081	Bush	PTFE(ally)	
107	Wear ring	AISI316+PTFE	
111	Mechanical seal Cartridge ass'y	SiC/Carbon/FPM316	
115-1	O-ring (outer)	FPM	
115-2	O-ring (stage)	FPM	
120-1	Tie-rod bolt	Zincate steel with 6.8 strength class ISO 898/1	
120-2	Stack bolt	AISI304	AISI316
120-3	Bolt (mechanical seal)	Stainless steel A2-70 ISO3506	
120-4	Bolt (casing cover)	Stainless steel A2-70 ISO3506	
120-5	Bolt (coupling M-side)	Zincate steel with 8.8 strength class ISO 898/1	
120-6	Bolt (coupling P-side)	Zincate steel with 8.8 strength class ISO 898/1	
120-7	Bolt (bearing)	Zincate steel with 8.8 strength class ISO 898/1	
120-8	Bolt (bearing housing)	Zincate steel with 8.8 strength class ISO 898/1	
120-9	Bolt (bottom bearing)	Stainless steel A2-70 ISO3506	
120-12	Bolt (shaft end)	Stainless steel A2-70 ISO3506	
128-1	Nut (tie-rod bolt)	Zincate steel with 6S strength class ISO 898/2	
128-2	Nut (Stack bolt)	AISI304	
129	Bearing nut (coupling)	Carbon steel	
130-1	Screw (mechanical seal)	Stainless steel A2-70 ISO3506	
130-2	Screw (coupling guard)	Stainless steel A2-70 ISO3506	
130-3	Screw (mechanical seal)	Stainless steel A2-70 ISO3506	
130-4	Screw (coupling pin)	Strength class 45H ISO898/5	
131-1	Pin (shaft)	CF35SMnPb10	
135-1	Washer (tie-rod bolt)	Zincate steel	
135-2	Spring washer (Stack bolt)	AISI304	AISI316
135-3	Spring washer (coupling bolt M-side)	Zincate steel	
135-4	Spring washer (bearing)	Zincate steel	
135-5	Spring washer (shaft end)	AISI304	AISI316
136	Bearing washer (coupling)	Carbon steel	
137-1	Shaft end sleeve	AISI304	AISI316
137-2	Shaft end sleeve	AISI304	AISI316
140-1	Coupling upper half	Steel (36SMnPb14)	
140-2	Coupling lower half	Steel (36SMnPb14)	
163	Motor stool	Cast iron EN-GJL-200	
212	Vent plug (with seal ring)	AISI304/FPM	AISI316/FPM
217	Plug (with seal ring)	AISI304/FPM	AISI316/FPM
245	Coupling guard	AISI304	
274-1	C-ring (top)	AISI304	AISI316
613	Pump flange	C40	

(For reference only. See pricing for part availability.)