Model EPD, Optima PRO Drainer™

Submersible Sump/Drainage Pump



Operating Instructions, Installation & Maintenance Manual



**Note: UL and CSA listed; Model Optima UL certified only.*



EBARA Fluid Handling

EBARA International Corporation



Thank you for purchasing this EBARA Stainless Steel Sump Pump. We hope you are pleased with your purchase and that our pumps will provide you with long service life and exceptional performance.

To ensure satisfactory service life, there are several considerations regarding proper installation, operation and power source. Please review the recommendations outlined within the installation and operation manual.

Please contact your supplier (supplying dealer or contractor) if service is necessary or if you have any questions or need further assistance.

Please retain the following information for your records and to help expedite service:

Purchase Date: _____

Purchased From: _____

Serial No: _____

(Located on the pump nameplate)

Note: For assistance locating the serial number and name plate, please refer to page 17 of your owner's manual.

Important Safeguards

To reduce risk of injury, **always** follow these instructions and safety precautions when using this pump and to maintain warranty.

Read All Instructions Prior to Installation (SAVE THESE INSTRUCTIONS)

Installation/Operation:

- Never lift or carry pump by the electrical cord. Use a chain or rope affixed on handle to install/remove pump. To reduce potential damage to the pump from inadvertent lifting by the electrical cord, please refer to “Proper Lifting” located on the following page.
- Pump(s) are able to operate whether fully or partially submerged (*please refer to Typical Installation Diagram, page 14*). Pump must be shutdown if sump, pit or pond level drops below the motor housing.
- Pump is designed to pump clean water (maximum temperature of 122°F) with suspended solids up to 3/8 of an inch. Larger solids will clog the suction strainer plate leading to dry running and subsequent failure (**Note: Pumping sand, gravel, and other hard debris will shorten the life of the pump**). Elevate the pump with bricks or other support above the sump, pit or pond bottom if debris is present. Consult dealer for other fluids.
- Clean filter basin when cleaning inlet filter media when pump is shutdown.
- If used with a float switch, the float must have a full range of motion to operate properly without obstruction. Consult dealer for minimum dimensions required for proper float operation.
- Pump should be mounted upright only (vertical). Never lay the pump on its side.

Electrical Requirements:

- Pump must be operated with a GFI breaker of at least 20 amps.
- High OR Low Voltage can damage the pump. Power from your utility or generator set cannot be more or less than $\pm 5\%$ of the rated voltage on the pump.
- Maximum distance from power source and pump must not exceed 100 feet using 16/3 electrical cables. This distance is from the breaker box and includes the pump cord. If the run is longer, consult a qualified electrician or your dealer.
- Lightning strikes can destroy the capacitor in your pump. Ensure proper protection is provided.
- Consult operator manual for other operation and application information.



Important Safeguards

Proper Lifting:

A separate chain or rope should be attached to the handle for normal lifting.

Please note that this will help prevent damage due to inadvertent lifting of the pump by the power cord.



Rope attached to automatic pump for lifting and installation.



Rope attached to manual pump for lifting and installation.

Contents

Section	Page
General Application Information	7
Safety Information and Introduction & Specifications	9
Materials/Tools & Installation Instructions	10
Pump Inspection & Installation Instructions	11
Fixed Application Diagram & Performance Table	13
Manual Operation Type Motor Wiring Diagram	15
Automatic Operation Type Motor Wiring Diagram	15
Three Phase Motor Wiring Diagram	16
Specifications	18
Nameplate Data & Model No./Item No. Explanation	20
Troubleshooting Checklist & Maintenance Info	21
Date Code Information	22
Sectional View & Parts Reference	23
Disassembly & Assembly Info	32
Warranty Information	33

General Application Information

The Sump and Installation

If your basement does not currently have a sump installed, it would be necessary to check local plumbing codes as to the acceptable type of sump that may be used. Materials commonly specified are: clay tile, fiberglass, steel, concrete and polyethylene. It may be necessary to cut a hole in the basement floor and excavate for the sump. Plumbing and electrical contractors could advise you on proper installations of drain tiles, sump, pump and electrical service. EBARA recommends that a solid sump base be provided. The sump is fed by drain tile placed around the outside and/or inside basement walls at the footings. In applications where a gravel base must be used to relieve hydraulic pressure under the basement floor, be sure to provide a permanent and solid base for the pump (bricks or a steel plate). A sump cover capable of supporting 200 pounds should be employed to contain odors and for obvious safety reasons.

Electrical Installation

Electrical service for any sump pump installation must be grounded and separately fused or breakered directly from the entrance box with a single grounding type receptacle at the pump. The receptacle should not be less than four feet above the basement floor for



General Application Information (cont.)

safety reasons. You should never touch a sump pump or discharge piping while the pump is connected to electrical power and water is present. The pump should be disconnected from the electrical source before handling in all cases.

Discharge Piping Installation

To assure the maximum performance from your sump pump, the discharge pipe size and piping fittings should not be smaller than the discharge port of the pump. Smaller pipe will add to friction losses and reduce the capacity of the pump. Normally accepted materials are galvanized pipe, rigid plastic pipe or acceptable flexible pipe or hose. A piece of flexible hose between the pump discharge and the discharge piping will provide for ease in alignment, reduce vibration and noise, and will act as a union when it is necessary to remove the pump. Where the discharge pipe is long, a check valve is often employed to prevent the water from flowing back into the sump when the pump turns off. If the discharge is directed into a sanitary sewer, a suitable anti-siphon device or a free flow check valve should be inserted in the line to prevent backflow into the pit. Sump pumps are not designed to handle raw sewage. Do not attempt to adapt one for this type of application. A sewage ejector pump especially designed to handle solids must be used.

Pump Installation

When the sump, electrical and discharge plumbing installation is complete and ready for the pump, clean all solid debris from the pit. Complete the plumbing connection to the pump and then plug the pump into the electrical outlet. A few extra minutes to test the sump pump installation are now in order. Fill the sump with water, note the turn on and turn off level of the pump, and the pumping cycle. This will allow you to calculate the approximate discharge flow of the pump system. If everything is operating properly, install the sump cover.

Pump Selection

The pump should be of sufficient capacity and head to satisfy anticipated use requirements. Capacity is determined by a fixture unit value if effluent is drained to sump basin. Your local Wholesaler can assist you in fixture unit values.

Basement perimeter water intrusion varies by area and region. Typically a 1/3 HP or 1/2 HP DRAINAGE PUMP WILL EVACUATE MOST HOME SUMP PITS.

Commercial and industrial drainage applications require that calculations of pumping volume and pumping head be performed to determine the proper size pump is applied.

NOTE: Pumping volume may vary seasonally due to rainfall and area run-off.



General Application Information (cont.)

Basin and Cover

The basin should not be less than 18 inches in diameter and 24 inches deep.

Larger diameters are advisable in instances of increased pump capacity requirements:

Required Pump Capacity	Minimum Basin Diameter
up to 35 GPM	18"
over 35 GPM	24"
over 60 GPM	30"
over 100 GPM	36"
over 150 GPM	48"

The basin should be located such that all water flows into the basin due to gravity.

Outdoor installations should be at a sufficient depth to ensure protection from freezing.

Note: Optima-3SS1 and EPD-3SS1 slimline automatic can operate in a 12" diameter basin or 8" x 8" square basin.

Maintenance Tips

- **Every three or four months:**

1) Clean the pump screen or inlet opening. If your sump collects the discharge from an automatic washing machine, cleaning will be required more often. (Before removing the pump be sure to disconnect the unit from electrical power; and reconnect after completion of cleaning);

2) Pour enough water into the sump to cycle the pump and assure its proper functioning.

- **Annually:**

Remove and clean the pump. Clean the sump pit also.

Safety Information and Introduction

WARNING



Before handling this pump, always disconnect the power first.

This pump should only be serviced by a qualified person or a factory trained person.

CAUTION

This instruction manual includes necessary items for installation, operation and maintenance. Read this manual carefully to ensure correct installation, operation and maintenance.

Be sure to keep this instruction manual on hand for future reference.

Specifications

CAUTION

Be careful not to exceed the given specifications in the use of your products.

Check the nameplate for your pump's head (HEAD), discharge volume (CAPACITY), speed (SPEED), motor voltage and current. Other specifications are noted in the chart below:

ITEM NO.	MODEL	DISCHARGE	MOTOR	MOTOR	WEIGHT	
		DIA.	OUTPUT	PHASE	VOLTAGE	
		INCH	(HP)			
MANUAL OPERATION						
Optima-3MS1	32Z707U6.3S/A	1¼	1/3	1	115	11
EPD-3MS1	32P707U6.3S/A	1¼	1/3	1	115	11
EPD-5MS1	40P707U6.6S	1½	1/2	1	115	27
EPD-5MT2	40P707U6.62	1½	1/2	3	230	27
EPD-5MT4	40P707U6.64	1½	1/2	3	460	27
EPD-7MS1	40P707U6.9S	1½	3/4	1	115	28
EPD-7MT2	40P707U6.92	1½	3/4	3	230	28
EPD-7MT4	40P707U6.94	1½	3/4	3	460	28
EPD-10MT2	40P707U61.12	1½	1	3	230	31
EPD-10MT4	40P707U61.14	1½	1	3	460	31
EPD-15MT2	40P707U61.32	1½	1½	3	230	31
EPD-15MT4	40P707U61.34	1½	1½	3	460	31

20 FT POWER CORDS – AVAILABLE ON MOST MODELS

ITEM NO.	MODEL	DISCHARGE	MOTOR	MOTOR	WEIGHT	
		DIA.	OUTPUT	PHASE	VOLTAGE	
		INCH	(HP)			
AUTOMATIC OPERATION						
Optima-3AS1	32Z707AU6.3S/A	1¼	1/3	1	115	11
EPD-3AS1	32P707AU6.3S/A	1¼	1/3	1	115	11
EPD-5AS1	40P707AU6.6S	1½	1/2	1	115	27
EPD-7AS1	40P707AU6.9S	1½	3/4	1	115	27

20 FT POWER CORDS – AVAILABLE ON MOST MODELS

ITEM NO.	MODEL	DISCHARGE	MOTOR	MOTOR	WEIGHT	
		DIA.	OUTPUT	PHASE	VOLTAGE	
		INCH	(HP)			
SLIMLINE AUTOMATIC OPERATION						
Optima-3SS1	32Z707SU6.35S/A	1¼	1/3	1	115	11
EPD-3SS1	32P707SU6.35S/A	1¼	1/3	1	115	11

20 FT POWER CORDS – AVAILABLE ON MOST MODELS

Tools Needed

- Screw driver
- Pipe wrench
- Adjustable wrench (medium-large)
- Hacksaw with 24-tooth blade for cutting plastic pipe
- Knife or round file for smoothing inside of all plastic pipe connections



EBARA Fluid Handling

www.pumpsebara.com

(t) 803 327-5005 • (f) 803 327-5097

Materials Needed

- PVC or ABS pipe cement (*read manufacturer's instructions carefully*)
- PVC or ABS pipe;
 - 1 $\frac{1}{4}$ " for Optima-3 & EPD-3
 - 1 $\frac{1}{2}$ " for EPD-5,7,10 & 15
- PVC adapter
 - 1 $\frac{1}{4}$ " for Optima-3 & EPD-3
 - 1 $\frac{1}{2}$ " for EPD-5, 7, 10 & 15
- In line check valve
- Sump basin 18" or larger diameter plastic, fiberglass or concrete.
(See page 2 for minimum diameter basin size by pump capacity.)
- Optional: gate valve
(see installation drawing on page 6)

Installation Instructions

Step 1 Inspection: Your pump has been carefully packaged to prevent damage during shipping. However, occasional damage does occur due to rough handling. Carefully inspect the pump for damage that could cause it to fail.

Step 2: Attach desired length of PVC or ABS discharge pipe to pump outlet, using PVC adapter (1 $\frac{1}{4}$ " pipe and adapter for Optima-3 & EPD-3 1 $\frac{1}{2}$ " for EPD-5, 7, 10 & 15). Make sure open end of pipe will be above top of basin.

Step 3: Clear sump basin of any water, debris or sediment.

Step 4: Lower pump into basin.

Step 5: Attach in line check valve to discharge pipe 12" to 18" above pump discharge with arrow pointing away from the pump (with the flow). Connect other end of check valve securely to drain pipe and tighten clamps.

Note: Do not put check valve directly into pump discharge opening.

Step 6: Drill a 1/8" relief hole in the discharge pipe 5" above pipe connection to pump.

Step 7: Plug in pump and fill sump basin with water to test unit. Pump should turn on at 13" to 14" water level. Allow pump to go through several ON-OFF cycles to assure satisfactory operation.

Note: If pump does not operate properly, see the troubleshooting checklist on page 12.

Septic Tank Installation

The PRO•DRAINER pumps can be used to pump septic tank effluent, but must be installed as follows:

- Install pump in separate compartment at the discharge side of the septic tank. Never install pump in main tank where sludge collects.
- Use with a junction box.

WARNING: Sump basin must be vented in accordance with local plumbing codes. These pumps are not designed for and CANNOT be installed in locations classified as hazardous in accordance with the National Electric Code, ANSI/NEPA 70-1984.



Electrical information – Single Phase *(Refer to page 16 for Three phase information)*

- Pumps are 115 V, 60 Hz and are grounded to prevent electrical shock.

WARNING: Risk of electric shock—this pump is supplied with a grounding conductor and grounding-type attachment plug. To reduce the risk of electric shock, be certain that it is connected only to a properly grounded, grounding-type receptacle.

- Use a separate 20 amp circuit breaker or 20 amp fuse block with the pump.
- **Do not** use an extension cord with the pump.
- **Do not** cut off the ground pin or use an adapter fitting.
- **Do not** work on the pump or switch until any or all power cords are unplugged.

IMPORTANT INSTRUCTIONS BEFORE INSTALLATION

Failure to follow these instructions may cause serious bodily injury and/or property damage.

1. Before installing or servicing your pump, BE CERTAIN pump power source is disconnected.
2. Installation and electrical wiring must adhere to state and local codes and must be complete before priming pump. Check appropriate community agencies, or contact local electrical and pump professionals.
3. **CALL AN ELECTRICIAN WHEN IN DOUBT.** Pump should be connected to a separate 20 amp circuit breaker or 20 amp fuse block. Plugging into existing outlets may cause low voltage at motor, causing blown fuses, tripping of motor overload, or burned out motor.
4. Do not connect pump to a power supply until permanently grounded. For maximum safety, ground pump to a circuit equipped with a fault interrupter device.
5. Voltage of power supply must match the voltage of the pump.
6. Before installing pump, clear sump basin of any water, debris, or sediment.
WARNING: Sump basin must be vented in accordance with local plumbing codes. EBARA PRO•DRAINERS are not designed for and CANNOT be installed in locations classified as hazardous in the National Electric Code, ANSI/NFPA 70.
7. The sump basin should be between 18" and 24" in diameter and made of plastic, fiberglass, or concrete.
8. The following may cause severe damage to pump and will void warranty:
 - Using an extension cord.
 - Cutting off the ground pin or using an adapted fitting.
 - Working on pump or switch while plugged in.
 - Removing motor housing, unscrewing impeller, or otherwise removing impeller seal.

PIPING

Plastic PVC pipe is shown in the illustrations, but galvanized steel or copper pipe may be used if desired. All piping must be clean and free of all foreign matter to prevent clogging. Use thread compound on all threaded joints unless specified otherwise.



Submersible Pump Installation

Refer to the installation illustration on the following page for the following instructions. Be certain sump basin is clean and all power to pump is shut off. If pump fails to operate properly after installation, refer to the troubleshooting checklist on page 12 or contact EBARA.

General Materials Needed

- One can PVC cement (read instructions carefully)
- One can thread compound (read instructions carefully)
- One male PVC adaptor: 1¹/₄" for 1/3 HP; 1¹/₂" for 1/2, 3/4, 1 & 1¹/₂ horsepower models.
- Enough rigid PVC pipe and couplings to reach from bottom of sump basin to discharge: 1¹/₄" for 1/3 HP; 1¹/₂" for 1/2, 3/4, 1 & 1¹/₂ horsepower models.
- One Check Valve.

Tools Needed for all pump installations:

Pipe wrench, slot screwdriver, 24-tooth hacksaw, knife or round file.

Step 1 – Thread male PVC adaptor into pump discharge opening.

Step 2 – Cement a 15" piece of PVC pipe to adaptor. Use appropriate diameter piping. Drill a 1/8" relief hole in the pipe 5" above pump connection. This hole prevents pump from air-locking.

Step 3 – Clamp Check Valve to top of 15" PVC pipe with water flow arrow pointing away from pump.

Step 4 – Lower pump into basin. Clamp needed PVC discharge pipe and fittings to open end of Check Valve.

Step 5 – Plug in pump and fill sump basin with water. Pump should turn on at 13" to 14" water level. Perform several ON-OFF cycles to assure satisfactory operation.

Performance Table (Capacity in Gallons per Minute)

TOTAL HEAD ITEM NO		5	10	15	20	25	30	35	40	45	50	55
Optima-3 1/3 HP	GPM	40	33	25	14							
EPD-3 1/3 HP	GPM	45	38	31	20	7						
EPD-5 1/2 HP	GPM		66	67	49	40	29	17				
EPD-7 3/4 HP	GPM				63	54	45	35	25	14		
EPD-10 1 HP	GPM				74	65	56	46	36	26	15	
EPD-15 1 1/2 HP	GPM				85	77	68	58	48	38	26	15



EBARA Fluid Handling

www.pumpsebara.com

(t) 803 327-5005 • (f) 803 327-5097

PRO Drainer Submersible (Typical) Installation Diagram

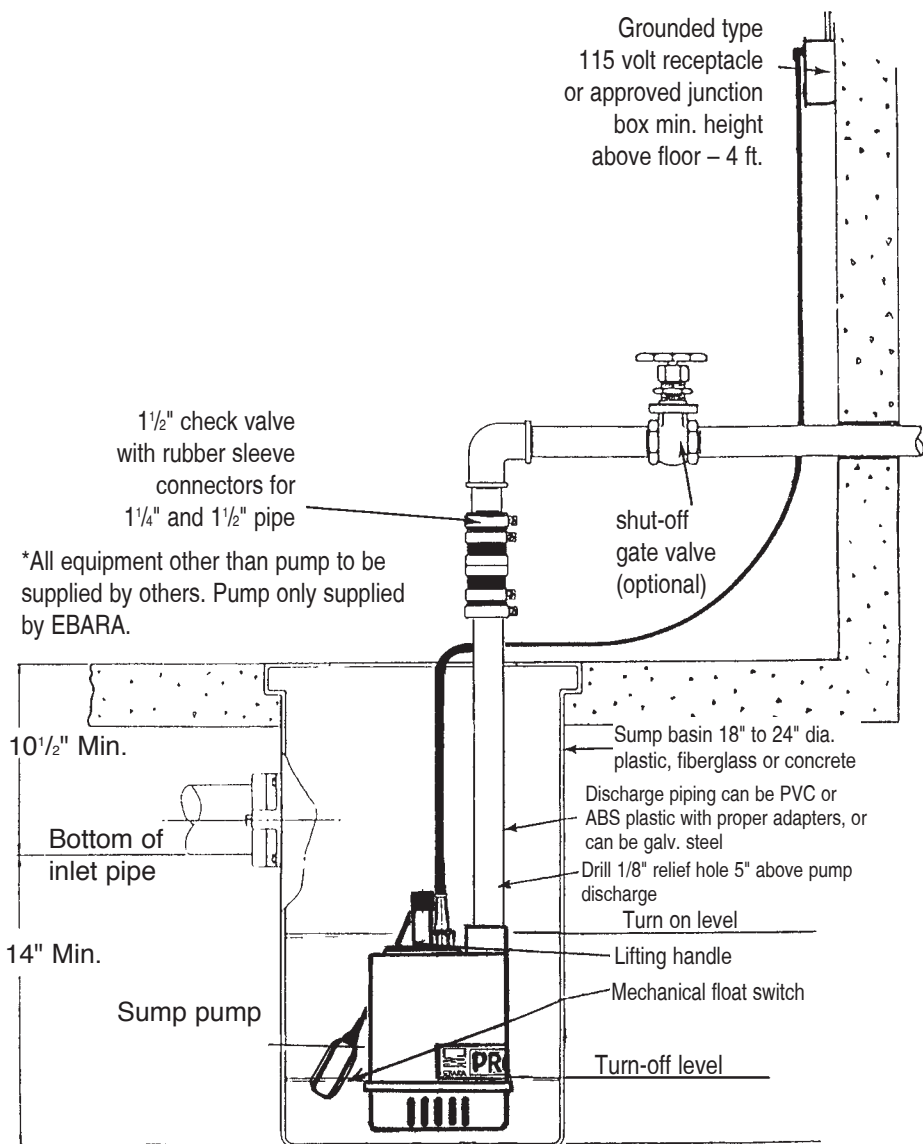

Note: Optima-3SS1 and EPD-3SS1 slimline automatic can operate in a 12" diameter basin or 8" x 8" square basin.

Motor Wiring Diagram

Manual Operation Type Output (Single Phase)

- Output $\frac{1}{3}$ to $\frac{3}{4}$ HP

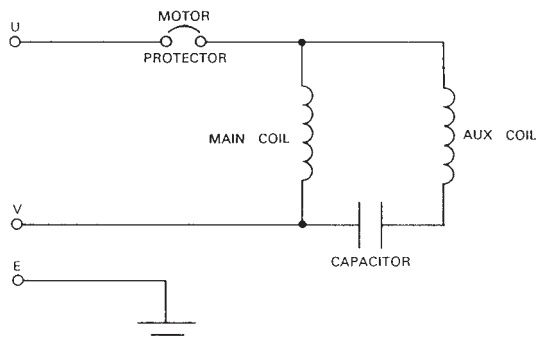

Manual Operation Type Output (Three Phase)

- Output $\frac{1}{2}$ to $1\frac{1}{2}$ HP

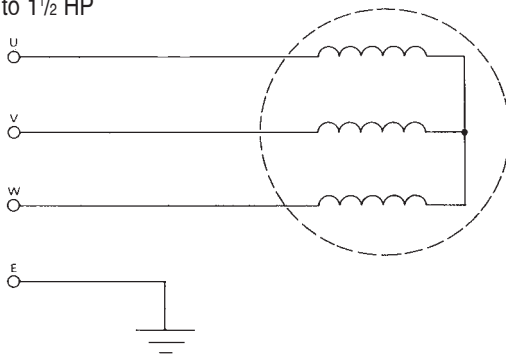

Automatic Operation Type Output (Single Phase)

- Output $\frac{1}{3}$ to $\frac{3}{4}$ HP

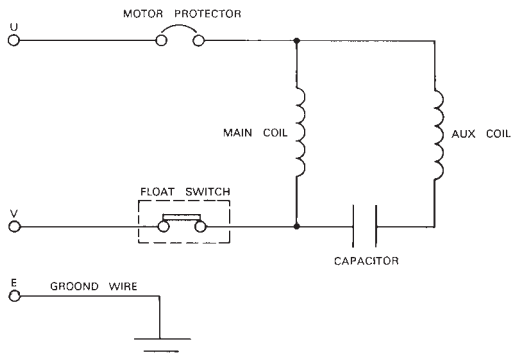

Electrical Wiring – Three Phase

WARNING



Check that the power is locked off and disconnected before working on pump. All electric work should be performed by a qualified electrician and all national and local electrical codes must be observed.

(1) Wiring

- a) Wire as indicated for the appropriate start system as shown in Fig. 4
- b) Loose connections will stop the pump. Make sure all electrical connections are secure.

MOTOR WIRING DIAGRAM

- Model P707U
- Output 1/2 to 1 1/2 HP

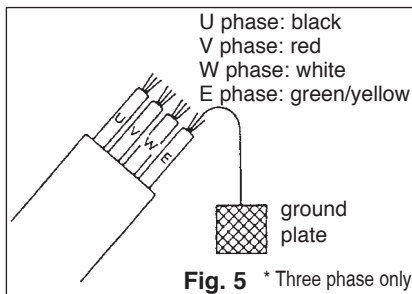
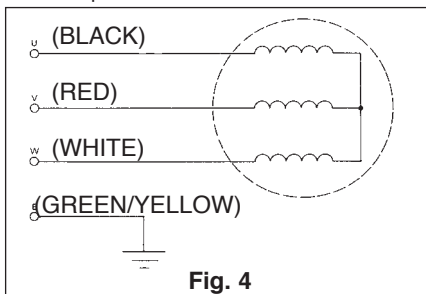

NOTE:

Use with approved motor control that matches motor input in full load amperes with overload element(s) selected or adjusted in accordance with control instructions.

Utiliser un démarreur approuvé convenant au courant à pleine charge du moteur et dont les éléments thermiques sont réglés ou choisis conformément aux instructions qui l'accompagnent.

(2) Cable

- a) Never let the end of the cable contact water.
- b) If the cable is extended, do not immerse the splice in water.
- c) Fasten the cable to the discharge piping with tape or vinyl strips.
- d) Install the cable so that it will not overheat. Overheating is caused by coiling the cable and exposing it to direct sunlight.

(3) Grounding

As shown in Fig. 5 ground the green/yellow wire (label E). Under no circumstances should the green/yellow wire be connected to the power supply.

(4) Use short circuit breakers to prevent danger of electrical shock.

OPERATION

1. Before starting the pump:

- (1) Check water level.

SPECIAL NOTICE

for Cord Connected Pumps

EBARA EPD / Optima PRO Drainer pumps are NOT designed for and **CANNOT be installed** in any location classified as **hazardous** by the National Electric Code ANSI/NFPA 70.

- Connection devices shall provide for a watertight connection to the power supply and provide adequate strain relief for the cord.
- Installation of the box shall be a Listed watertight connection box used with a Listed, liquid-tight fitting suitable for the cord.
- Connection boxes should be sized in accordance with National Electric Code specifications and installed as intended for the application.
- All connection devices are to be provided by the installer.
- Only qualified personnel shall service and install the pump.

Specifications

Model **Optima-3AS1**
 EPD-3AS1
 Optima-3SS1
 EPD-3SS1
 EPD-5AS1 and EPD-7AS1

Automatic Operation Pumps

Performance: ISO 2548

	Standard	Optional
Discharge Size	1/3 HP – 1 1/4 inch 1/2 HP and 3/4 HP – 1 1/2 inch	
Range of HP	1/3, 1/2, and 3/4 HP	
Range of Performance	Capacity 2.7 to 72 GPM Head 9.3 to 57 feet	
Limitation Maximum Water Temperature	122°F/50°C	
Solids	3/8" Spherical (2% by concentration)	
Speed	3600 RPM	
Materials Casing Impeller Shaft Motor Frame Fasteners	304L Stainless Steel 304L Stainless Steel* 303 Stainless Steel 304L Stainless Steel 304L Stainless Steel	
Shaft Seal (Double)** Material – Upper Side Material – Lower Side Impeller Type Bearing Motor Single Phase Motor Protection Power Cord Automatic Float Switch	NBR Fitted Carbon/Ceramic 1/2, 3/4, 1, and 1 1/2 HP NBR Fitted SiC/SiC 1/2, 3/4, 1, and 1 1/2 HP Semi-Open Sealed Ball Bearing Air-filled, Insulation Class F, 2 Pole, Rated Continuous Duty– Permanent Split Capacitor 115 Volt Built-in Motor Protection with Auto Reset UL/CSA SJTow-A with ECS No. 250 capplug with grounding pin – 20 Ft. Length Rated 15 Amp 125V – NEMA 5-15P Mechanical Float	

* ITEM NO. Optima-3AS1 – Impeller material is Thermo Plastic-Noryl GFN2

** Optima-3 & EPD-3 – 1/3 HP Shaft Seal is single mechanical seal (lower side) and 1 lip seal (upper side)
– Mechanical Seal material: Carbon/Ceramic/FPM



EBARA Fluid Handling

www.pumpsebara.com

(t) 803 327-5005 • (f) 803 327-5097

Specifications

**Model Optima-3MS1
EPD-3MS1
EPD-5 to 15**

Manual Operation Pumps

Performance: ISO 2548

	Standard	Optional
Discharge Size	1/8 HP – 1 1/4 inch	
Range of HP	1/2 HP through 1 1/2 HP – 1 1/2 inch	
Range of Performance	1/3, 1/2, 3/4, 1, and 1 1/2 HP Capacity 2.7 to 86 GPM Head 9.3 to 61 feet	
Limitation Maximum Water Temperature	122°F/50°C	
Solids	3/8" Spherical	
Speed	3600 RPM	
Materials Casing Impeller Shaft Motor Frame Fasteners	304L Stainless Steel 304L Stainless Steel* 303 Stainless Steel 304L Stainless Steel 304L Stainless Steel	
Shaft Seal (Double)** Material – Upper Side Material – Lower Side Impeller Type Bearing Motor Single Phase Three Phase Motor Protection† Power Cord Single Phase Three Phase	NBR Fitted Carbon/Ceramic 1/2, 3/4, 1, and 1 1/2 HP NBR Fitted SiC/SiC 1/2, 3/4, 1, and 1 1/2 HP Semi-Open Sealed Ball Bearing Air-filled, Insulation Class F, 2 Pole, Rated Continuous Duty–Permanent Split Capacitor 115 V 230V or 460V Built-in Motor Protection with Auto Reset (Single Phase Only) UL/CSA SJTOW-A with ECS No. 250 cap plug with grounding pin – 20 Ft. Length Rated 15 Amp 125V – NEMA 5-15P UL/CSA STOW-A water resistant, stripped end jacket removed 2" and conductor stripped 5/8" – 20 Ft. length	

* ITEM NO. Optima-3AS1 – Impeller material is Thermo Plastic-Noryl GFN2

** Optima-3 & EPD-3 – 1/2 HP Shaft Seal is single mechanical seal (lower side) and 1 lip seal (upper side)
– Mechanical Seal material: Carbon/Ceramic/FPM

† Three Phase models require user to provide motor protection

Nameplate & Model No./Item No. Explanation
NAME PLATE

EBARA PUMP			
No. (Serial Number) ①			
Model ②			
CAP.	USGPM	③	⑤
HEAD	FT	④	⑥
⑦ PHASE INDUCTION MOTOR			
⑧ kW	⑨ HP	60 Hz	
⑩ V	⑪ A		A
POLE 2	INS. CLASS F	MAX. AMB. 122° F	
MOTOR MODEL ⑫			
EBARA INTERNATIONAL CORPORATION ROCK HILL, SOUTH CAROLINA			

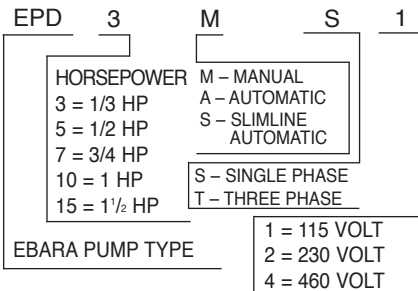
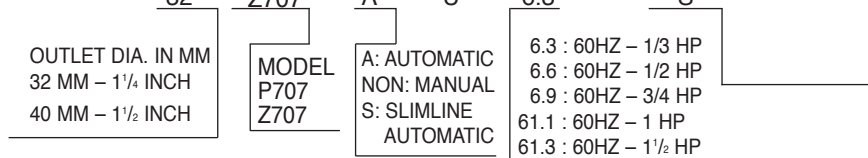
EPD SERIES PRO-DRAINER
ITEM No. DESIGNATION:
EXAMPLE:

MODEL No. DESIGNATION:
EXAMPLE:

①	②	③	④	⑤	⑥	⑦	⑧	⑨	⑩	⑪	⑫
Optima-3MS1	32Z707U6.3S/A	40	5	5	23	1	0.3	1/3	115	4	SM
Optima-3AS1	32Z707AU6.3S/A	↓	↓	↓	↓	↓	↓	↓	↓	↓	SA
Optima-3SS1	32Z707SU6.3S/A	↓	↓	↓	↓	↓	↓	↓	↓	↓	
EPD-3MS1	32P707U6.3S/A	45	5	5	25						SM
EPD-3AS1	32P707AU6.3S/A	↓	↓	↓	↓	↓	↓	↓	↓	↓	SA
EPD-3SS1	32P707SU6.3S/A	↓	↓	↓	↓	↓	↓	↓	↓	↓	
EPD-5MS1	40P707U6.6S	73	10	40	30		0.6	1/2		9	SM
EPD-5AS1	40P707AU6.6S	↓	↓	↓	↓	↓	↓	↓	↓	↓	SA
EPD-5MT2	40P707U6.62	↓	↓	↓	↓	3	↓	↓	230	3.1	SM
EPD-5MT4	40P707U6.64	↓	↓	↓	↓	↓	↓	↓	460	1.55	SM
EPD-7MS1	40P707U6.9S	58.5	30	16	50	1	0.9	3/4	115	12.0	SM
EPD-7AS1	40P707AU6.9S	↓	↓	↓	↓	↓	↓	↓	↓	↓	SA
EPD-7MT2	40P707U6.92	↓	↓	↓	↓	3	↓	↓	230	3.8	SM
EPD-7MT4	40P707U6.94	↓	↓	↓	↓	↓	↓	↓	460	2	SM
EPD-10MT2	40P707U61.12	83.5	20	27	50		1.1	1	230	4.8	SM
EPD-10MT4	40P707U61.14	↓	↓	↓	↓	↓	↓	↓	460	2.5	SM
EPD-15MT2	40P707U61.32	81.5	30	42	50		1.3	1 1/2	230	5.3	SM
EPD-15MT4	40P707U61.34	↓	↓	↓	↓	↓	↓	↓	460	2.7	SM



Troubleshooting Checklist

PROBLEM	POSSIBLE CAUSES
Pump does not run or hums.	<ul style="list-style-type: none"> • Line circuit breaker is off, or fuse is blown or loose. • Water level in sump has not reached turn-on level as indicated in installation drawing. • Pump cord is not making contact in receptacle. • Float is stuck. It should operate freely in basin. • If all of the above are OK, then the motor winding may be open.
Pump runs but does not deliver water.	<ul style="list-style-type: none"> • Check valve is installed backwards. Arrow on valve should point in direction of flow. • Discharge shut-off valve (if used) may be closed. • Pump is air-locked. Start and stop several times by plugging and unplugging cord. Check for clogged vent hole in pump case. • Impeller or volute openings are fully or partially clogged. Remove pump and clean. • Inlet holes in pump base are clogged. Remove pump and clean the openings. • Vertical pumping distance is too high. Reduce distance or resize pump.
Pump runs and pumps out sump, but does not stop.	<ul style="list-style-type: none"> • Float is stuck in up position. Be sure float operates freely in basin. • Defective float switch.
Pump runs but delivers only a small amount of water.	<ul style="list-style-type: none"> • Pump is air-locked. Start and stop several times by plugging and unplugging cord. Check for clogged vent hole in pump case. • Vertical pumping distance is too high. Reduce distance or resize pump. • Inlet holes in pump base are clogged. Remove pump and clean the openings. • Impeller or volute openings is fully or partially clogged. Remove pump and clean.
Fuse blows or circuit breaker trips when pump starts.	<ul style="list-style-type: none"> • Pump impeller is partially clogged with tar or paint, causing motor to run slow and overload. Remove pump and clean. • Pump impeller is partially clogged with tar or paint, causing motor to run slow and overload. Remove pump and clean. • Motor stator may be defective. • Fuse size or circuit breaker may be too small. • Impeller or volute openings are fully or partially clogged. Remove pump and clean.
Motor runs for a short time, then stops.	<ul style="list-style-type: none"> • Inlet holes in pump base are clogged. Remove pump and clean the openings. • Pump impeller is partially clogged with tar or paint, causing motor to run slow and overload. Remove pump and clean. • Motor stator may be defective. • Impeller or volute openings are fully or partially clogged. Remove pump and clean.

Maintenance and Service

WARNING: Pump warranty becomes void if you remove motor housing, unscrew impeller, or otherwise remove impeller seal.

If pump does not operate properly, follow the steps shown under Troubleshooting.

For any work on pump or switch, always unplug power cord(s). Do not just turn off circuit breaker or unscrew fuse.

Cleaning float

If pump becomes inoperative because of trash accumulation on the float, remove pump from sump and clean float switch.

Wipe all water and dirt from the pump and float switch.

Be sure float switch operates freely after cleaning.

Cleaning impeller and volute case

Remove screws that hold lower base to housing.

CAUTION: Do not remove motor housing or unscrew impeller. Use screwdriver to pry base from housing. Pry in several places.

Be sure impeller turns freely after cleaning. Clean out holes in the pump base and wash thoroughly before replacing.

Manufacturing Year and Month



YEAR	INDICATION
2002	C
2003	D
2004	E
2005	F
2006	G
2007	H
2008	J
2009	K
2010	L
2011	M
2012	N
2013	O
2014	P
2015	Q

MONTH	INDICATION
JAN.	1
FEB.	2
MAR.	3
APR.	4
MAY	5
JUN.	6
JUL.	7
AUG.	8
SEP.	9
OCT.	X
NOV.	Y
DEC.	Z

Sectional View – Optima-3MS1

Manual Type Output

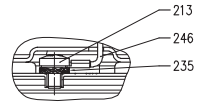
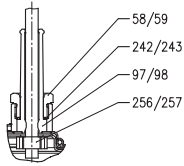

Ground Wire

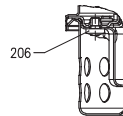
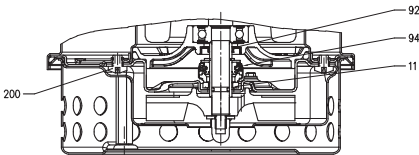
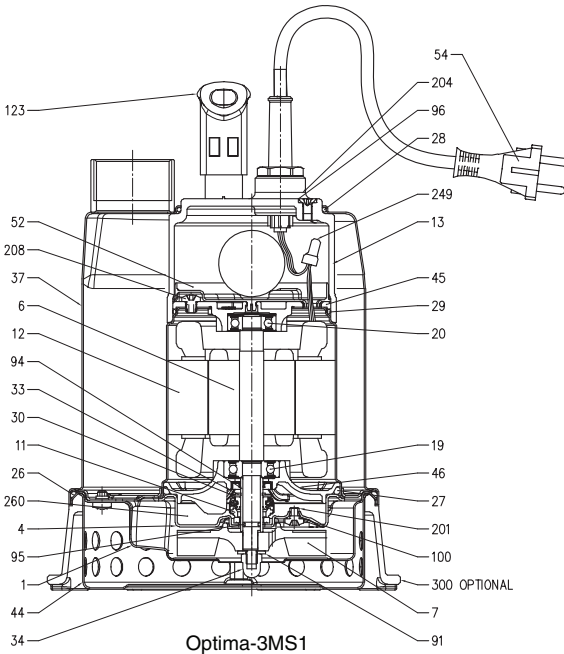

Suction Cover

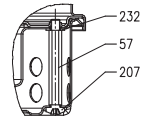

Strainer

Refer to page 29 for Material Details.

Sectional View – EPD-3MS1

Manual Type Output

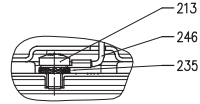
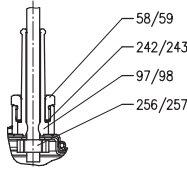

Ground Wire

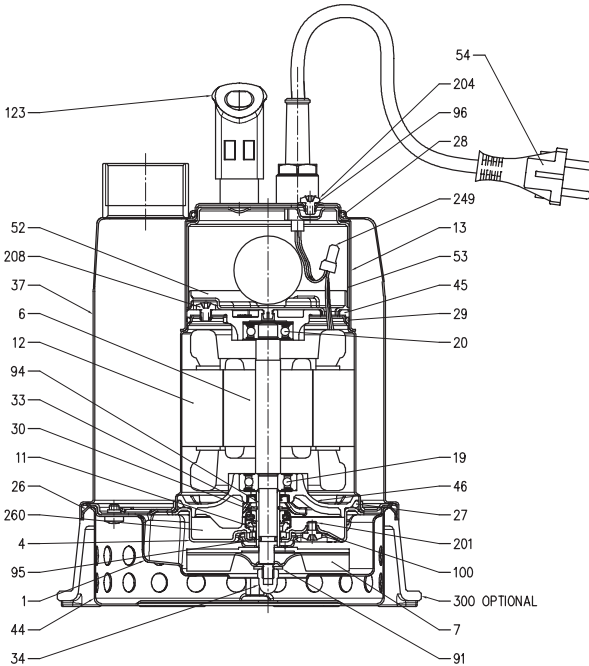

EPD-3MS1

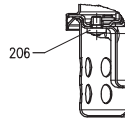
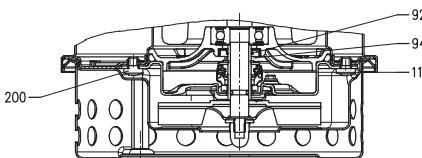

Suction Cover

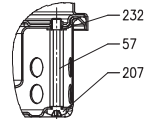

Strainer

Refer to page 31 for Material Details.

Sectional View – P707U / EPD-5MT2(4), 7MT2(4), 10MT2(4), 15MT2(4)

Manual Type Output 1/2 to 1 1/2 HP (Three Phase)

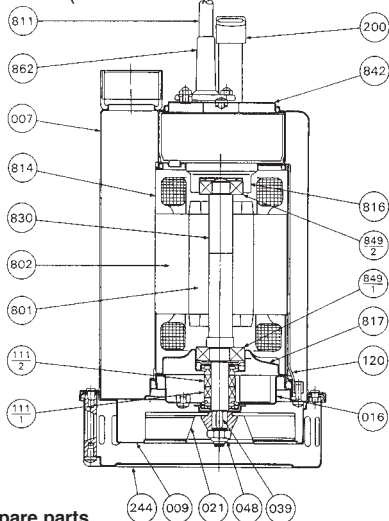
*** Recommended spare parts**

Part No. No.	Part Name	Material	ASTM, AISI Code	No. for 1 Unit
007	Outer Casing	304 Stainless	AISI 304	1
009	Inner Casing	304 Stainless	AISI 304	1
016	Seal Cover	304 Stainless	AISI 304	1
021	Impeller	304 Stainless	AISI 304	1
039	Key	304 Stainless	AISI 304	1
048	Impeller Nut	304 Stainless	AISI 304	1 set
*111-1	Mechanical Seal	—		1 set
*111-2	Mechanical Seal	—		1 set
120	Connection Band	304 Stainless	AISI 304	
200	Lifting Hanger	304 Stainless	AISI 304	1
244	Strainer	304 Stainless	AISI 304	1
801	Rotor	—		1
802	Stator	—		1
811	Submersible Cable	SOW-A/SO		1
814	Motor Frame	304 Stainless	AISI 304	1
816	Bracket	304 Stainless	AISI 304	1
817	Bracket	304 Stainless	AISI 304	1
830	Shaft	303 Stainless	AISI 303	1
842	Motor Cover			1
*849-1	Ball Bearing	—		1
*849-2	Ball Bearing	—		1
862	Cable Foot	NBR		1

Sectional View

Automatic Type Output 1/2 to 3/4 HP (Single Phase)

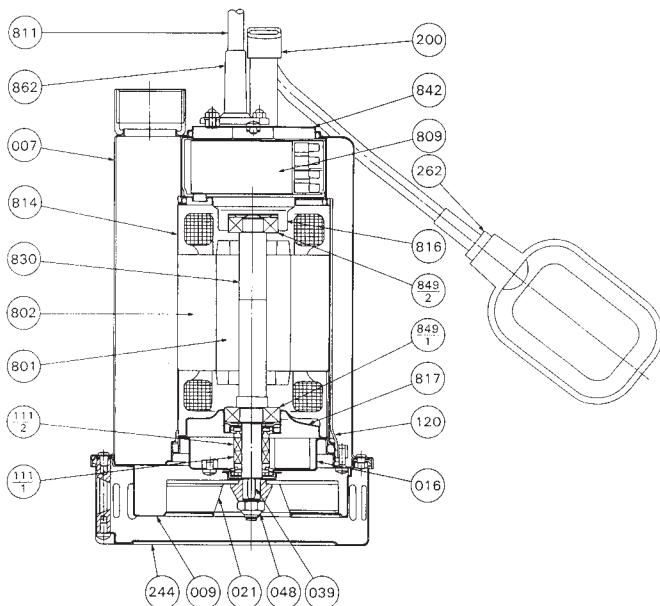

*** Recommended spare parts**

Part No.	Part Name	Material	ASTM, AISI Code	No. for 1 Unit
007	Outer Casing	304 Stainless	AISI 304	1
009	Suction Cover	304 Stainless	AISI 304	1
016	Seal Cover	304 Stainless	AISI 304	1
021	Impeller	304 Stainless	AISI 304	1
039	Key	304 Stainless	AISI 304	1
048	Impeller Nut	304 Stainless	AISI 304	1 set
*111-1	Mechanical Seal	—		1 set
*111-2	Mechanical Seal	—		1 set
120	Connection Band	304 Stainless	AISI 304	
200	Lifting Hanger	304 Stainless	AISI 304	1
244	Strainer	304 Stainless	AISI 304	1
262	Float Switch	—		1

Part No.	Part Name	Material	ASTM, AISI Code	No. for 1 Unit
801	Rotor	—		1
802	Stator	—		1
809	Capacitor	—		1
811	Submersible Cable	—		1
814	Motor Frame	304 Stainless	AISI 304	1
816	Bracket	304 Stainless	AISI 304	1
817	Bracket	304 Stainless	AISI 304	1
830	Shaft	303 Stainless	AISI 303	1
842	Motor Cover	—		1
*849-1	Ball Bearing	—		1
*849-2	Ball Bearing	—		1
862	Cable Boot	NBR		1

Sectional View

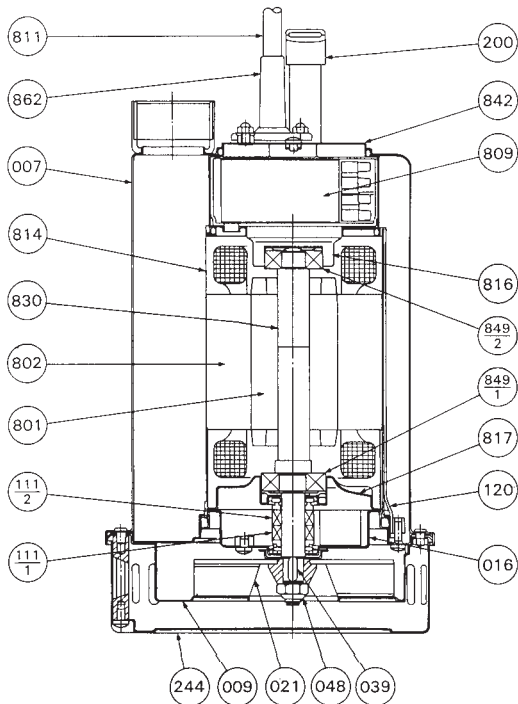
Manual Type Output 1/2 to 3/4 HP (Single Phase)



*** Recommended spare parts**

Part No.	Part Name	Material	ASTM, AISI Code	No. for 1 Unit
007	Outer Casing	304 Stainless	AISI 304	1
009	Inner Casing	304 Stainless	AISI 304	1
016	Seal Cover	304 Stainless	AISI 304	1
021	Impeller	304 Stainless	AISI 304	1
039	Key	304 Stainless	AISI 304	1
048	Impeller Nut	304 Stainless	AISI 304	1 set
*111-1	Mechanical Seal	—		1 set
*111-2	Mechanical Seal	—		1 set
120	Connection Band	304 Stainless	AISI 304	1
200	Lifting Hanger	304 Stainless	AISI 304	1
244	Strainer	304 Stainless	AISI 304	1
801	Rotor	—		1

Part No.	Part Name	Material	ASTM, AISI Code	No. for 1 Unit
802	Stator	—		1
809	Capacitor	—		1
811	Submersible Cable	—		1
814	Motor Frame	304 Stainless	AISI 304	1
816	Bracket	304 Stainless	AISI 304	1
817	Bracket	304 Stainless	AISI 304	1
830	Shaft	303 Stainless	AISI 303	1
842	Motor Cover	—		1
*849-1	Ball Bearing	—		1
*849-2	Ball Bearing	—		1
862	Cable Boot	NBR		1

Sectional View – Optima-3AS1, 3SS1

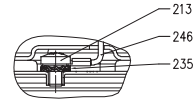
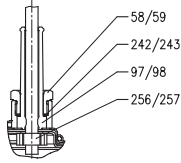
Automatic Type Output



Ground Wire

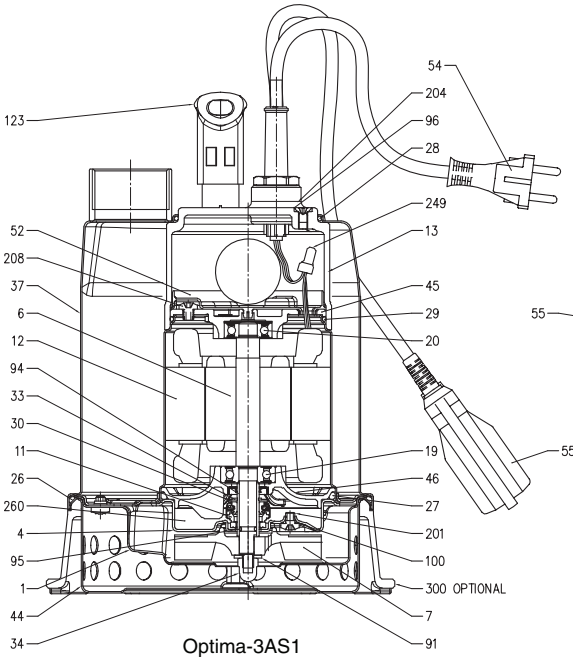

Optima-3AS1

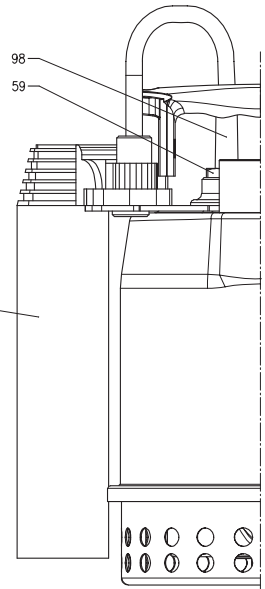

Optima-3SS1

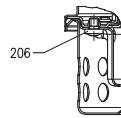
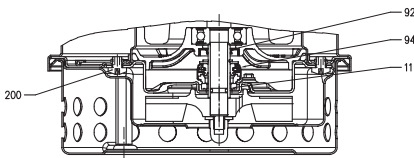

Suction Cover

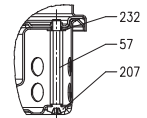

Strainer

Sectional View – Optima-3AS1, 3SS1, 3MS1

N°	PART NAME	MATERIAL	STANDARD	Qty.
1	Suction cover	EN 1.4301 (AISI 304)	-	1
4	Casing cover	EN 1.4301 (AISI 304)	-	1
6	Shaft with rotor	EN 1.4305 (AISI 303)	-	1
7	Impeller	PPE+PS-HI-GF20	-	1
11	Mechanical seal		-	1
12	Motor frame with stator	EN 1.4301 (AISI 304)	-	1
13	Motor cover	PP-GF30	-	1
19	Lower ball bearing	-	-	1
20	Upper ball bearing	-	-	1
21	Adjusting ring	-	-	1
23	Capacitor	-	-	1
26	O-ring	NBR	-	1
27	O-ring	NBR	-	1
28	O-ring	NBR	-	1
29	O-ring	NBR	-	1
30	Washer	EN 1.4301 (AISI 304)	-	1
33	Seeger ring	Carbon steel TC80	UNI 7435	1
34	Impeller nut	A2 - 70 UNI 7323	UNI 5721	1
37	Outer casing	EN 1.4301 (AISI 304)	-	1
44	Strainer	EN 1.4301 (AISI 304)	-	1
45	Upper bearing housing	EN 1706 AC-46000 D	-	1
46	Lower bearing housing	EN 1706 AC-46000 D	-	1
52	Terminal insulating base	PA6	-	1
54	Power cable	-	-	1
55	Switch	-	-	1
57	Spacer	EN 1.4301 (AISI 304)	-	2
58	Power cable connector	PA66-GF30	-	1
59	Switch cable connector	PA66-GF30	-	1
91	Washer	EN 1.4301 (AISI 304)	-	1
92	Lip seal	NBR	-	1
94	Shaft sleeve	EN 1.4305 (AISI 303) ceramic coated	-	1
95	O-ring	NBR	-	1
96	O-ring	NBR	-	1
97	Power cable boot	NBR	-	1
98	Switch cable boot	NBR	-	1
100	O-ring	NBR	-	1
123	Handle	PP	-	1
200	Screw	A2 - 70 UNI 7323	UNI 7687	4
201	Screw	A2 - 70 UNI 7323	UNI 7687	1
204	Screw	A2 - 70 UNI 7323	UNI 7687	1
206	Screw	A2 - 70 UNI 7323	UNI 7687	3
207	Screw	A2 - 70 UNI 7323	UNI 7687	2
208	Screw	A2 - 70 UNI 7323	UNI 7687	3
213	Screw	A2 - 70 UNI 7323	UNI 7687	1
232	Washer	PA6	-	2
235	Washer	Zinked Steel	UNI 8842	1
242	Washer	EN 1.4301 (AISI 304)	-	1
243	Washer	EN 1.4301 (AISI 304)	-	1
246	Ground wire	-	-	1
256	Cable holder	-	-	1
257	Cable holder	-	-	1
260	Oil	Esso Marcol 152	-	40 cc
300	Minimum suction system	Thermoplastic elastomer vulcanizate	-	-

Sectional View – EPD-3AS1, 3SS1

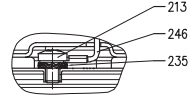
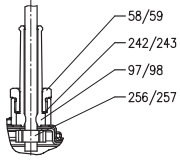

Ground Wire

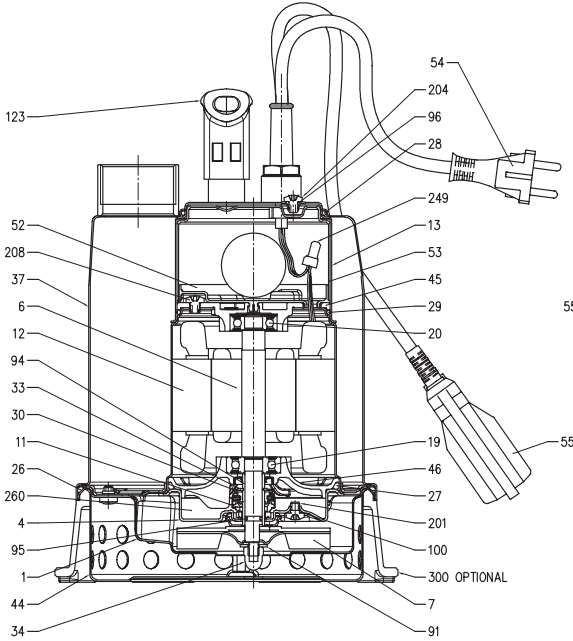

EPD-3AS1

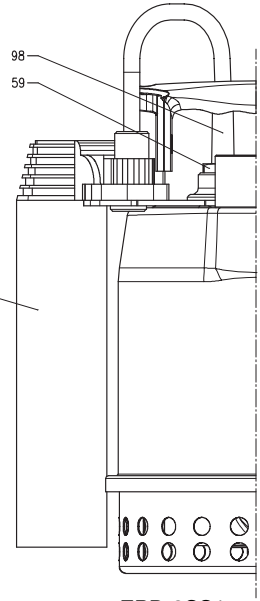

EPD-3SS1

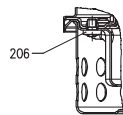
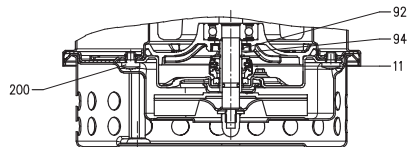

Suction Cover

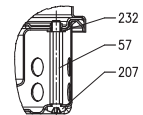

Strainer

Sectional View – EPD-3AS1, 3SS1, 3MS1

N°	PART NAME	MATERIAL	STANDARD	Qty.
1	Suction cover	EN 1.4301 (AISI 304)	-	1
4	Casing cover	EN 1.4301 (AISI 304)	-	1
6	Shaft with rotor	EN 1.4305 (AISI 303)	-	1
7	Impeller	EN 1.4301 (AISI 304)	-	1
11	Mechanical seal		-	1
12	Motor frame with stator	EN 1.4301 (AISI 304)	-	1
13	Motor cover	EN 1.4301 (AISI 304)	-	1
19	Lower ball bearing	-	-	1
20	Upper ball bearing	-	-	1
21	Adjusting ring	-	-	1
23	Capacitor	-	-	1
26	O-ring	NBR	-	1
27	O-ring	NBR	-	1
28	O-ring	NBR	-	1
29	O-ring	NBR	-	1
30	Washer	EN 1.4301 (AISI 304)	-	1
33	Seeger ring	Carbon steel TC80	UNI 7435	1
34	Impeller nut	A2 - 70 UNI 7323	UNI 5721	1
37	Pump casing	EN 1.4301 (AISI 304)	-	1
44	Strainer	EN 1.4301 (AISI 304)	-	1
45	Upper bearing housing	EN 1706 AC-46000 D	-	1
46	Lower bearing housing	EN 1706 AC-46000 D	-	1
52	Terminal insulating base	PA6	-	1
53	Terminal insulating box	PA6	-	1
54	Power cable	-	-	1
55	Switch	-	-	1
57	Spacer	EN 1.4301 (AISI 304)	-	2
58	Power cable connector	OT 58 UNI 5705-65 Nickel-plated Brass	-	1
59	Switch cable connector	OT 58 UNI 5705-65 Nickel-plated Brass	-	1
91	Washer	EN 1.4301 (AISI 304)	-	1
92	Lip seal	NBR	-	1
94	Shaft sleeve	EN 1.4305 (AISI 303) ceramic coated	-	1
95	O-ring	NBR	-	1
96	O-ring	NBR	-	1
97	Power cable connector	NBR	-	1
98	Switch cable connector	NBR	-	1
100	O-ring	NBR	-	1
123	Handle	PP	-	1
200	Screw	A2 - 70 UNI 7323	UNI 7687	4
201	Screw	A2 - 70 UNI 7323	UNI 7687	1
204	Screw	A2 - 70 UNI 7323	UNI 7687	1
206	Screw	A2 - 70 UNI 7323	UNI 7687	3
207	Screw	A2 - 70 UNI 7323	UNI 7687	2
208	Screw	A2 - 70 UNI 7323	UNI 7687	3
213	Screw	A2 - 70 UNI 7323	UNI 7687	1
232	Washer	PA6	-	1
235	Washer	Zinked Steel	UNI 8842	1
242	Washer	EN 1.4301 (AISI 304)	-	1
243	Washer	EN 1.4301 (AISI 304)	-	1
246	Ground wire	-	-	1
256	Strain relief	-	-	1
257	Strain relief	-	-	1
260	Oil	Esso Marcol 152	-	40 cc
300	Minimum suction system	Thermoplastic elastomer vulcanizate	-	-

Disassembly and Assembly

1. Disassembly

When disassembling pump, have a piece of cardboard or wooden board ready to place the different parts on as you work. Do not pile parts on top of each other. They should be laid out neatly in rows. The O-ring and gasket can not be used again once they are removed. Have replacement parts ready.

Disassemble in the following order, referring to the sectional view.

Be sure to cut off power source before beginning disassembly.

- (1) Loosen casing bolts and remove casing.
- (2) Loosen bolt at end of pump shaft and lift impeller off shaft.
- (3) Remove pump shaft key and mechanical seal. (No shaft key for 1/3 HP pumps.)
- (4) Loosen inner casing bolts and remove inner casing.

Note 1: Drain the lubricant oil into a container.

- (5) Remove the mechanical seal from the main shaft.

Note 2: Be careful not to cut your fingers on the shaft key groove when pulling out the mechanical seal.

Note 3: Be careful not to scratch or bend the pump shaft during disassembly.

2. Assembly

Re-assemble in reverse order of disassembly.

Be careful of the following points.

- (1) During re-assembly, rotate the impeller by hand and check for smooth rotation.
- (2) Replace the O-ring.
- (3) Replace all parts that are damaged.
- (4) Tighten bolts evenly.

Please obtain O-rings, and other parts from pump dealer.

* All specifications subject to change without notice.

In this catalog, the particulars in { } are in accordance with the International System of Units (SI) and given for reference only.

Warranty

**EBARA FLUID HANDLING
ROCK HILL, SOUTH CAROLINA
MODEL Optima NO FAULT LIMITED WARRANTY
(MODELS 3MS-1 AND 3AS-1 ONLY)**

EBARA FLUID HANDLING, Rock Hill, SC (EFH-RH) warrants to the original purchaser only ("Customer") that the EFH-RH Commercial Pump/Product ("Pump") Model 3MS-1 and/or 3AS-1 ONLY will be free of defects in workmanship and material for a period of twelve (12) months from the date of installation or eighteen (18) months from the date of shipment by EFH-RH, whichever comes first, provided that notification of any such defect is promptly given in writing to EFH-RH. Customer may be required at EFH-RH's request to verify that it is the Customer of the Pump and that the Pump was installed and operated in accordance with EFH-RH's instructions for sump pumps noted in the furnished instruction manual.

EFH-RH's sole obligation under this MODEL Optima NO FAULT LIMITED WARRANTY will be to replace the Pump or at EFH-RH's sole option, to refund the Customer an equitable part or the entire purchase price. In no event shall EFH-RH's cost responsibility exceed the initial purchase price paid by the Customer for the Pump. Freight charges for replacement Pumps under this MODEL Optima NO FAULT LIMITED WARRANTY are the responsibility of the Customer.

To obtain MODEL Optima NO FAULT LIMITED WARRANTY consideration, the original Pump label sticker affixed to the Pump must be removed, submitted and received by EFH-RH before replacement Pump or refund is provided at:

Ebara International Corporation
Attn: Optima Claims Processing
1651 Cedar Line Drive
Rock Hill, SC 29730
803-327-5005 Phone
803-327-5097 Fax

EFH-RH shall be liable only for the cost of the replacement Pump. Customer shall be responsible for labor, cost of removal and installation at Customer's premises, transportation and insurance costs to EFH-RH and any other incidental costs. This warranty is void and does not apply if damage is caused by improper installation, improper maintenance, accident, alteration, abuse, or misuse.

THE FOREGOING WARRANTY IS THE SOLE AND EXCLUSIVE WARRANTY ON THIS PUMP, AND ALL OTHER WARRANTIES, EXPRESSED OR IMPLIED, INCLUDING ANY WARRANTY OF MERCHANTABILITY OR FITNESS FOR A PARTICULAR PURPOSE, ARE DISCLAIMED AND EXCLUDED FROM THE TERMS OF THIS WARRANTY. EFH-RH'S SOLE OBLIGATION IN CASE OF ANY DEFECT WILL BE TO PROVIDE THE WARRANTY SERVICE SPECIFIED ABOVE. THE FOREGOING IS CUSTOMER'S SOLE AND EXCLUSIVE REMEDY, WHETHER IN CONTRACT, TORT OR OTHERWISE AND EFH-RH SHALL NOT BE LIABLE FOR ANY CONSEQUENTIAL OR INCIDENTAL DAMAGES OF ANY KIND WHATSOEVER.

**EBARA Fluid Handling**www.pumpsebara.com

(t) 803 327-5005 • (f) 803 327-5097

Warranty

COMMERCIAL PUMP/ PRODUCTS LIMITED WARRANTY

EbaraFluid Handling, Rock Hill, SC ("EFH-RH") warrants to the original purchaser only ("Customer") that the EFH-RH Commercial Pump/Product ("Pump") will be free of defects in workmanship and material for a period of twelve (12) months from the date of installation or eighteen (18) months from the date of shipment by EFH-RH, whichever comes first, provided that notification of any such defect is promptly given in writing to EFH-RH. Customer may be required at EFH-RH's request to verify that it is the Customer of the Pump and that the Pump was installed and operated in accordance with EFH-RH's instructions.

EFH-RH's sole obligation under this warranty will be to repair or replace with a new or reconditioned Pump, such Pump as has failed or has been found to be defective during the warranty period, or at EFH-RH's sole option, to refund to the customer an equitable part of the purchase price. In no event shall EFH-RH's cost responsibility exceed the initial purchase price paid by the Customer for the Pump.

EFH-RH shall be liable only for the cost of the Pump, or the cost of repair or replacement of any defective Pump. Customer shall be responsible for labor, cost of removal and installation at Customer's premises, transportation and insurance costs to EFH-RH and any other incidental costs.

This warranty is void and does not apply if damage is caused by improper installation, improper maintenance, accident, alteration, abuse, misuse or if the Pump has been disassembled prior to warranty evaluation without written authorization from EFH-RH.

Warranty service and information for return procedures will be provided by EFH-RH upon receipt of written notice describing the defect or problem to:

Ebara International Corporation
Warranty/Claims
1651 Cedar Line Drive
Rock Hill, SC 29730
803-327-5005 (Phone) • 803-327-5097 (Fax)

THE FOREGOING WARRANTY IS THE SOLE AND EXCLUSIVE WARRANTY ON THIS PUMP, AND ALL OTHER WARRANTIES, EXPRESSED OR IMPLIED, INCLUDING ANY WARRANTY OF MERCHANTABILITY OR FITNESS FOR A PARTICULAR PURPOSE, ARE DISCLAIMED AND EXCLUDED FROM THE TERMS OF THIS WARRANTY. EFH-RH'S SOLE OBLIGATION IN CASE OF ANY DEFECT WILL BE TO PROVIDE THE WARRANTY SERVICE SPECIFIED ABOVE. THE FOREGOING IS CUSTOMER'S SOLE AND EXCLUSIVE REMEDY, WHETHER IN CONTRACT, TORT OR OTHERWISE AND EFH-RH SHALL NOT BE LIABLE FOR ANY CONSEQUENTIAL OR INCIDENTAL DAMAGES OF ANY KIND WHATSOEVER.





*Contact your dealer or supplier
for more information about other EBARA products:*



EBARA Fluid Handling

1651 Cedar Line Drive • Rock Hill, SC 29730
(t) 803 327 5005 • (f) 803 327 5097

www.pumpsebara.com

© 2005 EBARA International Corporation

EFH EPD1001 0514
