

**Contents**

---

**Model**

A0553	C1125	V0494
A0713	C1285	V0554
A0843	C1455	V0754
A1003	C1605	V0854
	C1915	V0974
	C2185	V1154
	C2905	

Section	Page
Specifications	3-203
Model Designation	3-206
Impeller Data	3-208
Material Specifications	3-209
Selection Chart	3-210
Performance Curves	3-212
Outline Drawings	3-230
Sectional View	3-235
Technical Information	3-237.1
material specification	
impeller description	
motor protection	
cable entry	
paint specifications	
mechanical seal	
general	
Motor Data	3-267
motor electrical specifications	
cable data	
wiring diagrams	
motor electrical data	

**Features**

- **Watertight cable entry system** prevents capillary action and protects against moisture; reduces maintenance costs
- **Junction area** includes a terminal board for cable connections allowing for fast efficient replacement; area sealed from the stator housing; prevents leakage into the motor; reduces the possibility of failure
- **Heavy duty, high efficiency, air filled motor, Class F** insulated, rated for 311°F with a 1.10 service factor dissipates heat easily; thermal protection in each phase of windings; operates cooler with higher efficiencies; longer service life with lower operating costs
- **Double and triple row grease bearings** carries thrust loading with L-10 life of up to 100,000 hours; ensures long, dependable operation and lowers maintenance costs
- **Float type leakage detector** provides early warning of mechanical seal failure; avoids costly motor repairs
- **Cartridge type, duplex mechanical seals** assembled in tandem arrangement; easy maintenance and high reliability
- **High efficiency, axial flow impellers** accept large diameter solids; lowers operating costs
- **Replaceable case liner** maintains working clearances while lowering case replacement costs

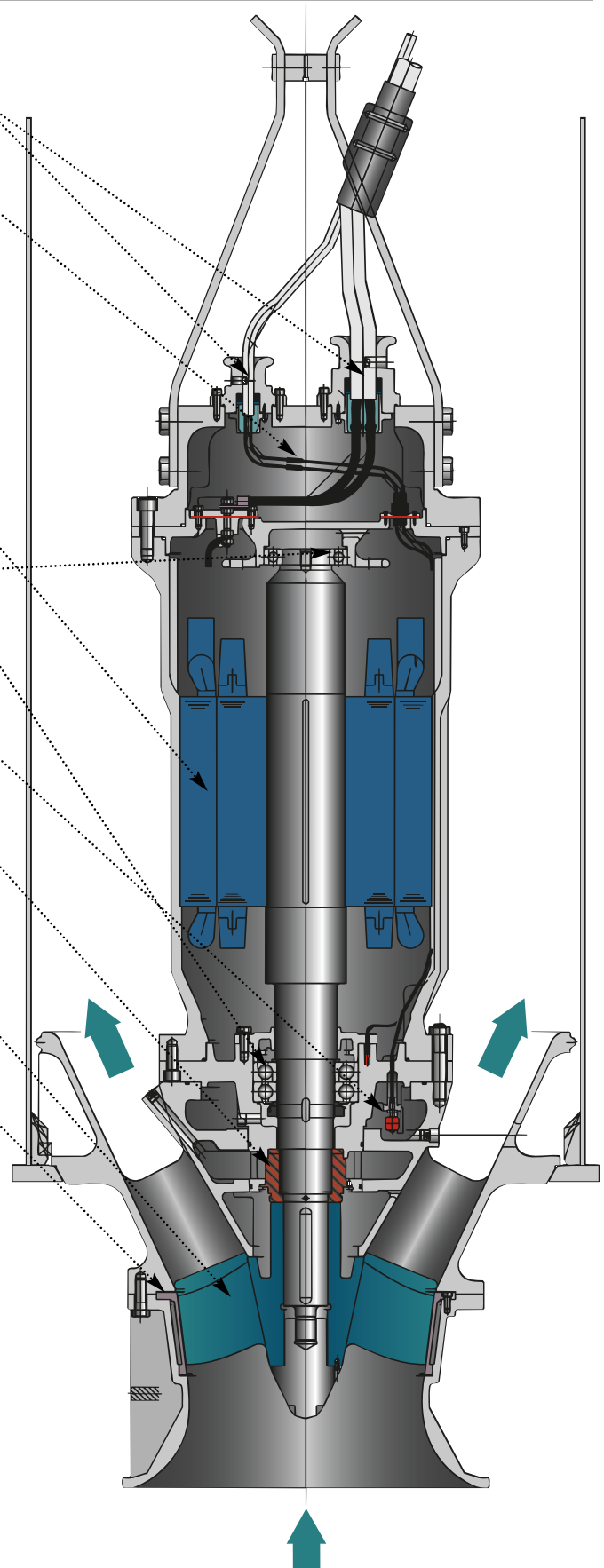

**Specifications**

	Standard	Optional
<b>Design</b> Discharge Size Range of input HP Range of Performance  Liquid Temperature Maximum (allowed) Submergence Speed	24 to 64 inch 10 to 422 HP Capacity 2500 to 55000 GPM Head 5 to 50 feet 32 to 104° F 114 feet (35 m) 1800, 1200, 900, 700, 600 RPM	
<b>Materials</b> Casing Impeller Shaft Motor Frame Fastener	Cast Iron Ductile Cast Iron 403 Stainless Steel Cast Iron 304 Stainless Steel	Bronze, Stainless Steel
<b>Construction</b> Impeller Type Shaft Seal  Material – Upper Side Material – Lower Side Bearing Mounting Method	Axial Flow or Mixed Flow Cartridge Type Duplex Mechanical Seal in Tandem Arrangement Carbon/Ceramic Silicon Carbide/Silicon Carbide Grease Lubricated Ball Bearing Sole Plate with Rotation Stopper	Impeller Wearing Ring  Carbon/Tungsten Carbide Tungsten Carbide/Tungsten Carbide
<b>Motor</b> Type Starting Method Hz, Voltage Protection	Air-filled Direct online 60Hz, 460V Built-in winding temperature detector Built-in float type leakage detector	FM Explosion Proof, Class 1, Division 1, Group C, D  Thrust bearing temperature detector
<b>Accessories</b>	Submersible cable 33 ft. Cable Glands for each cable Sole Plate with Rotation Stopper	Column Pipe
<b>Codes &amp; Standards</b>	ISO 9000 ISO 9001	

**Specifications**

---

**A. General:**

Provide FM explosion proof submersible axial flow pumps suitable for continuous duty operation underwater without loss of watertight integrity to a depth of 114 feet (35 m). Pump system design shall include a fabricated steel discharge tube in which the pump/motor unit is mounted, (see drawings for details). The pump shall be easily removable for inspection or service, requiring no bolts, nuts, or other fasteners to be disconnected, or the need for personnel to enter the wet well. Pumps shall be designed to allow for reverse rotation when the pump shuts off and the column drains. The motor and pump shall be designed, manufactured, and assembled by the same manufacturer.

**B. Manufacturer:**

EBARA International Corporation

**C. Pump Characteristics:**

Pumps shall conform to the following requirements:

Number of units

Design flow (gpm)

Design TDH (ft)

Minimum shut off head (ft)

RPM

Maximum HP

Minimum hydraulic efficiency at design (%)

Minimum power factor at design (%)

Voltage/HZ

460V / 60

Phase

3

**D. Pump Construction:**

All major parts of the pumping unit(s) including casing, suction bell, intermediate casing, discharge bowl, and motor frame shall be manufactured from gray cast iron, ASTM A-48 Class 35. Propeller shall be manufactured in ductile cast iron, ASTM A536 60-40 material. Castings shall have smooth surfaces devoid of blow holes or other casting irregularities. A replaceable casing wear liner shall be provided, manufactured of stainless steel, ASTM A743 CF8 material, to maintain working clearances and hydraulic efficiencies. All exposed bolts and nuts shall be 304 stainless steel. All mating surfaces of major components shall be machined and fitted with NBR O-rings where watertight sealing is required. Machining and fitting shall be such that sealing is accomplished by automatic compression of O-rings in two planes and O-ring contact is made on four surfaces without the requirement of specific torque limits. Surfaces in contact with the pumpage shall be surface prepared to SSPC-SP-10 and coated with three (3) coats of coal tar epoxy paint. The internal surface of the motor shall be surface prepared to SSPC-SP-3 and coated with one (1) coat of zinc rich primer paint. Surfaces in air shall be surface prepared to SSPC-SP-10 and coated with one (1) coat of zinc chromate primer and one (1) coat of alkyd resin enamel paint.

The propeller shall be an axial flow type available in 1 increments for efficient operation. The blades shall be fixed pitch, dynamically balanced and backward curved to reduce clogging. Impellers shall be direct connected to the motor shaft with a slip fit, key driven, and secured with an locking nut.

The pump/motor shall be mounted in a heavy duty fabricated A-36 steel discharge column with a minimum thickness of 1/2". The column diameter shall be sized so as to limit the velocity of the flow across the pump/motor unit to maximum 10.8 ft/sec. The design shall be such that the pump is lowered into the discharge column and comes to rest on the mounting plate. The suction bell extends below the mounting plate and a metal to metal contact seal is made between the discharge bowl and the mounting plate. No gaskets or O-rings shall be permitted. A rotation stopper welded to the interior of the column at the support plate shall come in contact with a cast extension of the discharge bowl to prevent rotation. The weight of the pump and the downward thrust when in operation shall hold the pump firmly in place. The column shall have a removable cover, easily removed or opened for inspection or service. The cover shall remain watertight during normal operation and shall include watertight cable entry provisions for both the power and control cables. It shall also include a cable support system to secure the cables within the column. The pump shall not require any nuts or bolts for fastening and shall be easily removable without the need for service personnel to enter the wetwell. Lifting chain, either galvanized or stainless steel, is suitable for removing and installing the pump unit.

---

**Contents**

---

The mechanical seal system shall be a cartridge mounted double mechanical seal in a tandem arrangement. Each seal shall be positively driven and act independently with its own spring system. The upper seal operates in an oil bath, while the lower seal is lubricated by the oil from between the shaft and the seal faces, and in contact with the pumpage. The oil filled seal chamber shall be designed to prevent over-filling and include an anti-vortexing vane to insure proper lubrication of both seal faces. Lower face materials shall be silicon carbide, upper faces carbon vs. Ceramic. NBR elastomers shall be provided in the oil chamber and viton elastomers where in contact with the pumpage. The mechanical seal hardware shall be 304SS. Seal system shall not rely on pumping medium for lubrication.

**E. Motor Construction:**

The pump motor shall be FM Explosion Proof, Class 1, Division 1, Groups C, D. The design shall be an air filled induction type with a squirrel cage rotor, shell type design, built to NEMA MG-1, Design B specifications. Stator windings shall be copper, insulated with moisture resistant Class F insulation, rated for 311 F. The stator shall be dipped and baked three times in Class F varnish and heat shrunk fitted into the stator housing. Rotor bars and short circuit rings shall be manufactured of cast aluminum. The motor junction area shall include a terminal strip for wire connections and shall be sealed with gaskets and O-rings from the motor stator housing. The motor shaft shall be one piece AISI403SS material, rotating on two permanently lubricated ball bearings designed for a minimum L-10 life of up to 100,000 hours. Motor service factor shall be 1.10 and capable of up to 10 starts per hour. The motor shall be designed for continuous duty pumping at a maximum sump temperature of 104 F. Voltage and frequency tolerances shall be a maximum 10 / 5% respectively. A thrust bearing RTD temperature monitor shall be provided. Motor over temperature protection shall be provided by miniature thermal protectors embedded in the windings. Mechanical seal failure protection shall be provided by a mechanical float switch located in a chamber above the seal. This switch shall be comprised of a magnetic float that actuates a dry reed switch encapsulated within the stem. Should the mechanical seal fail, liquid shall be directed into the float chamber, in which the rising liquid activates the switch opening the normally closed circuit. The float switch components shall be 304SS material. The motor shall be non overloading over the entire specified range of operation. The motor shall be cooled by the pumped water flowing along the stator housing during operation. A water jacket or any other external cooling systems are not acceptable.

The power and control cable jackets shall be manufactured of an oil resistant chloroprene rubber material, designed for submerged applications. Cable shall be watertight to a depth of at least 114 feet (35 m). The cable entry system shall comprise of primary, secondary, and tertiary sealing methods. The primary seal shall be achieved by an cylindrical elastomeric grommet compressed between the cable housing and cable gland. Secondary sealing is accomplished with a compressed O-rings made of NBR material. Compression and subsequent sealing shall preclude specific torque requirements. The system shall also include tertiary sealing to prevent leakage into the motor housing due to capillary action through the insulation if the cable is damaged or cut. The cable wires shall be cut, stripped, re-connected with a copper butt end connector, and embedded in epoxy within the cable gland. This provides a dead end for leakage through the cable insulation into the motor junction area. The cable entry system shall be the same for both the power and control cables.

Pump Model Name

Pump Description

**450 DSZ3**

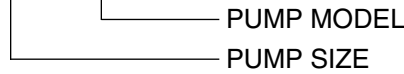

**\*PUMP SIZE**

Pump size of DSZ3 pump is defined by minimum pipe bore size in which flow velocity at pump rated capacity does not exceed 10.8 ft./sec. (3.3 m/sec).

**Example:**

Rated Capacity 8000 GPM

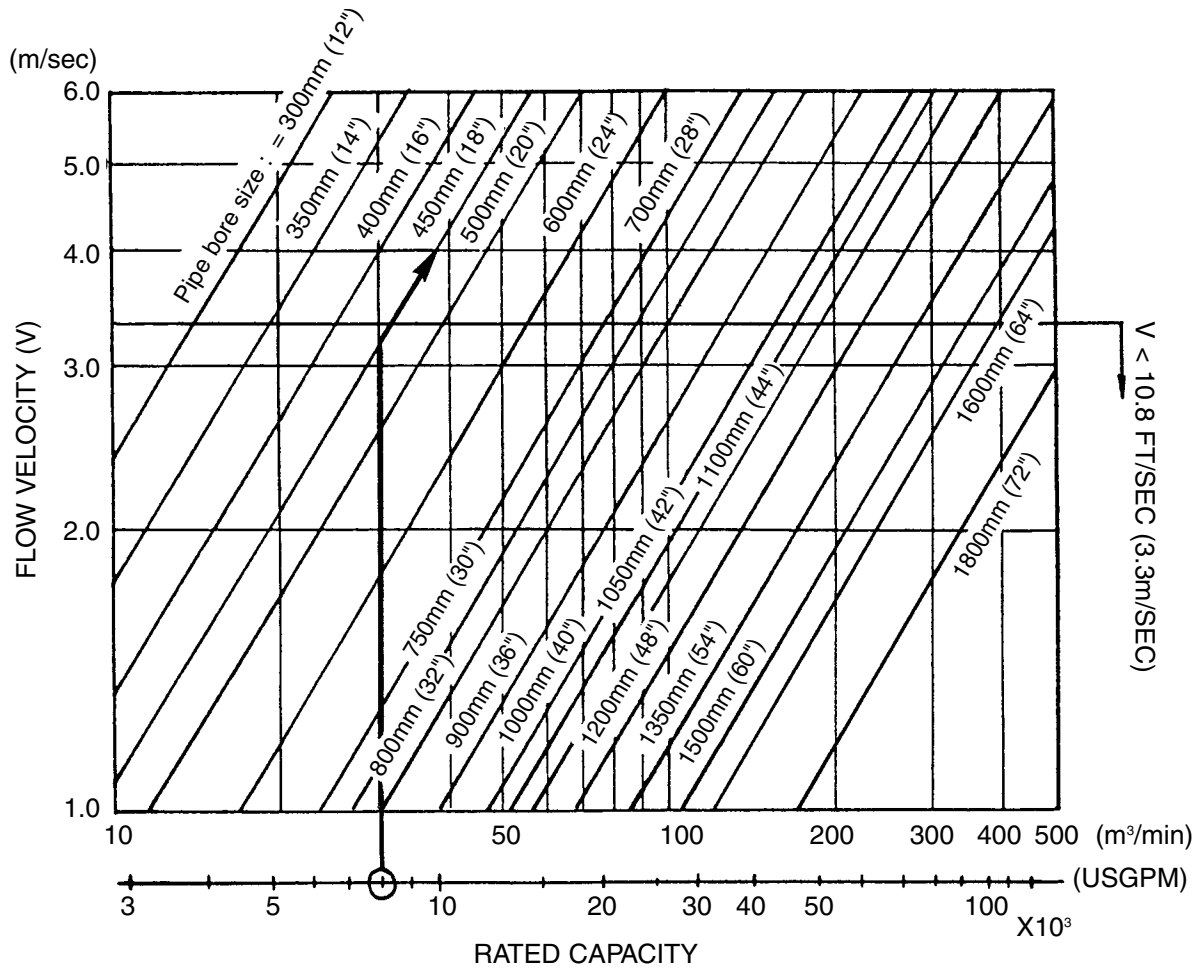

Installation

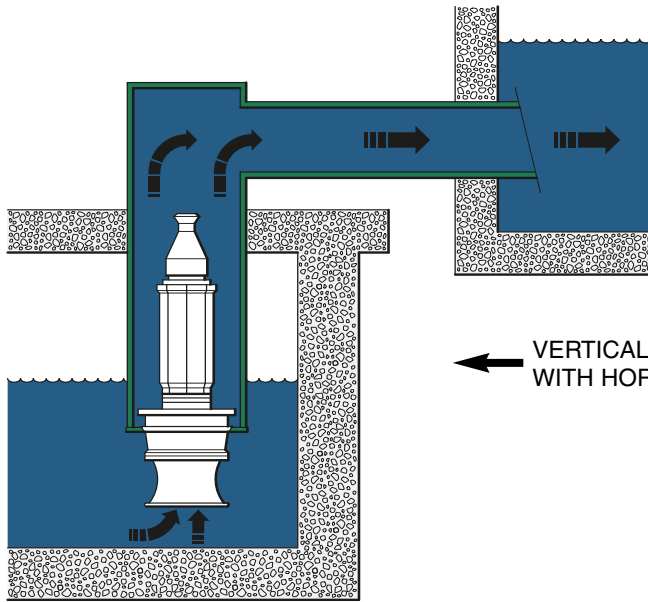

← VERTICAL SUSPENDED COLUMN WITH HORIZONTAL DISCHARGE

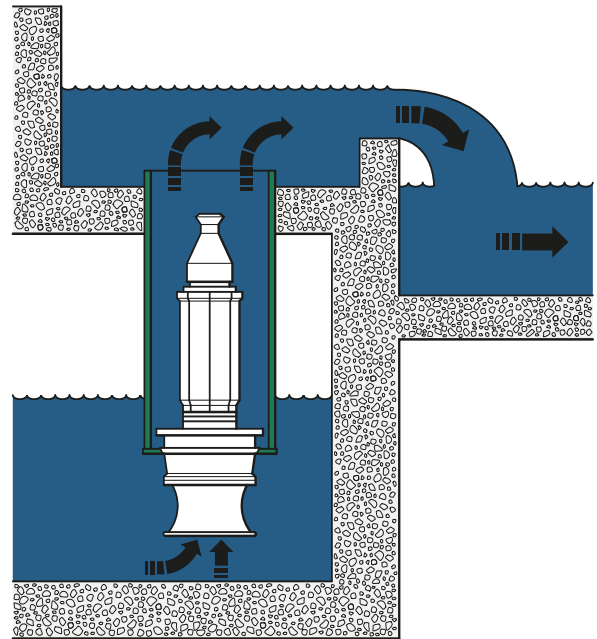

VERTICAL SUSPENDED COLUMN WITH VERTICAL DISCHARGE →

**Specifications**

---

**Impeller Design**

Curve No.	Type of Impeller	Nos. of Blades	Max. Solid Dia.
A0553	Axial Flow	3	3 <sup>9</sup> / <sub>16</sub> inch (90 mm)
A0713			4 <sup>9</sup> / <sub>16</sub> inch (116 mm)
A0843			5 <sup>7</sup> / <sub>16</sub> inch (138 mm)
A1003			6 <sup>7</sup> / <sub>16</sub> inch (164 mm)
C1125	Axial Flow	5	1 <sup>3</sup> / <sub>8</sub> inch (35 mm)
C1285			1 <sup>9</sup> / <sub>16</sub> inch (40 mm)
C1455			1 <sup>3</sup> / <sub>4</sub> inch (45 mm)
C1605			2 inch (50 mm)
C1915			2 <sup>3</sup> / <sub>8</sub> inch (60 mm)
C2185			2 <sup>11</sup> / <sub>16</sub> inch (68 mm)
C2905			3 <sup>9</sup> / <sub>16</sub> inch (91 mm)
V0494			Axial Flow
V0554	2 <sup>1</sup> / <sub>2</sub> inch (63 mm)		
V0754	3 <sup>7</sup> / <sub>16</sub> inch (87 mm)		
V0854	3 <sup>7</sup> / <sub>8</sub> inch (98 mm)		
V0974	4 <sup>7</sup> / <sub>16</sub> inch (112 mm)		
V1154	5 <sup>1</sup> / <sub>4</sub> inch (133 mm)		



**Material Specifications**

Parts	Standard		
	Type I	Type II	Type III
Discharge Bowl	Cast Iron ASTM A48 CL35	→	→
Suction Bell Mouth	Cast Iron ASTM A48 CL35	→	→
Casing Liner	Stainless Steel ASTM A743 CF8	→	→
Impeller	Ductile Cast Iron ASTM A536 60-40-18	Bronze ASTM B584 C90300	Stainless Steel ASTM A743 CF8
Shaft	Stainless Steel AISI 403	→	→
Motor Frame	Cast Iron ASTM A48 CL35	→	→
Mechanical Seal	Upper: Carbon/Ceramic Lower: Silicon Carbide/Silicon Carbide		

Option	
Mechanical Seal	Upper: Carbon/Tungsten Carbide Lower: Tungsten Carbide/Tungsten Carbide

Note:

1. Other materials may be used if requested.

**Selection Chart**

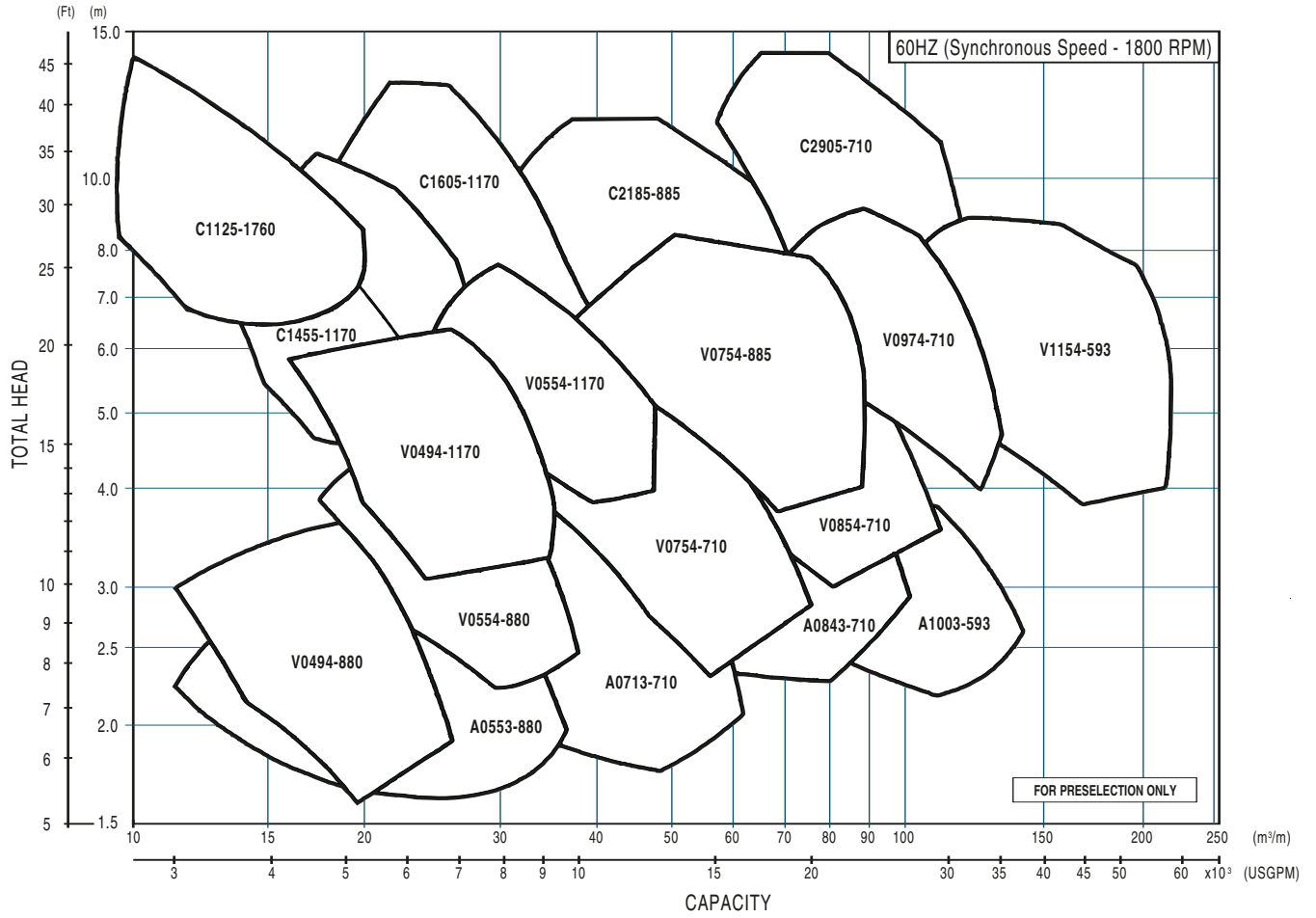

**Performance Curves**

**How to use Performance Curves**

Pump Size	Pump Model	Rated Capacity	Total Head	Pump Speed	Motor HP	Specific gravity of pumping liquid
<b>EBARA Submersible Propeller Pumps</b>						<b>DSZ3</b>
<b>Performance Curves</b>						
Curve No.	Project:	Chk'd:	Date:			
	Curve No. 40553-80U Rev.0					
<b>Model 400DSZ3</b>	GPM	FT	RPM	HP		
	6000	X 18.4	X 880	x40	r=1.0	

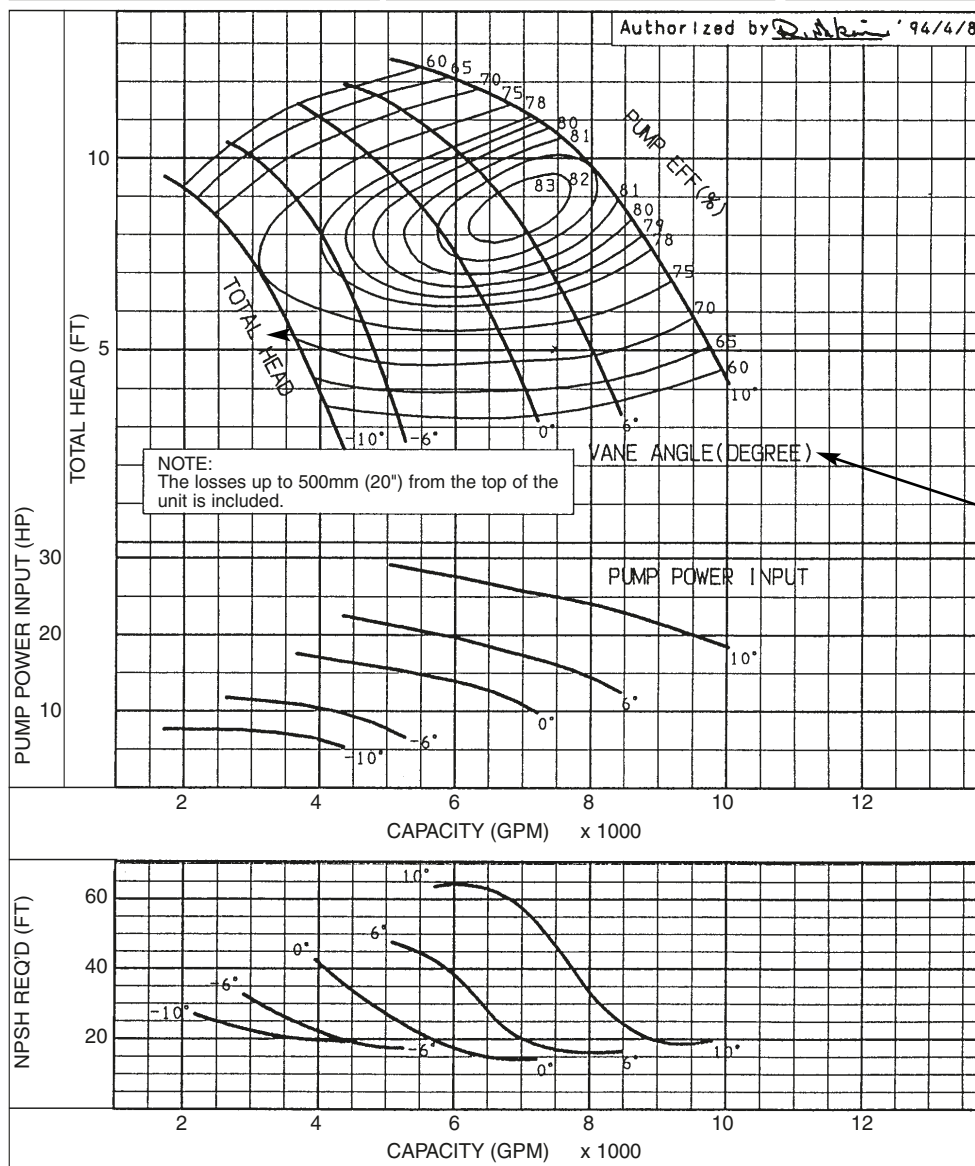

EBARA International Corporation  
3-212  
rev. 08/01



**Performance Curves**

Project:

Chk'd:

Date:

Curve No: A0553-880U Rev.0

**Model**

GPM

FT

RPM

HP

X

X

880

X

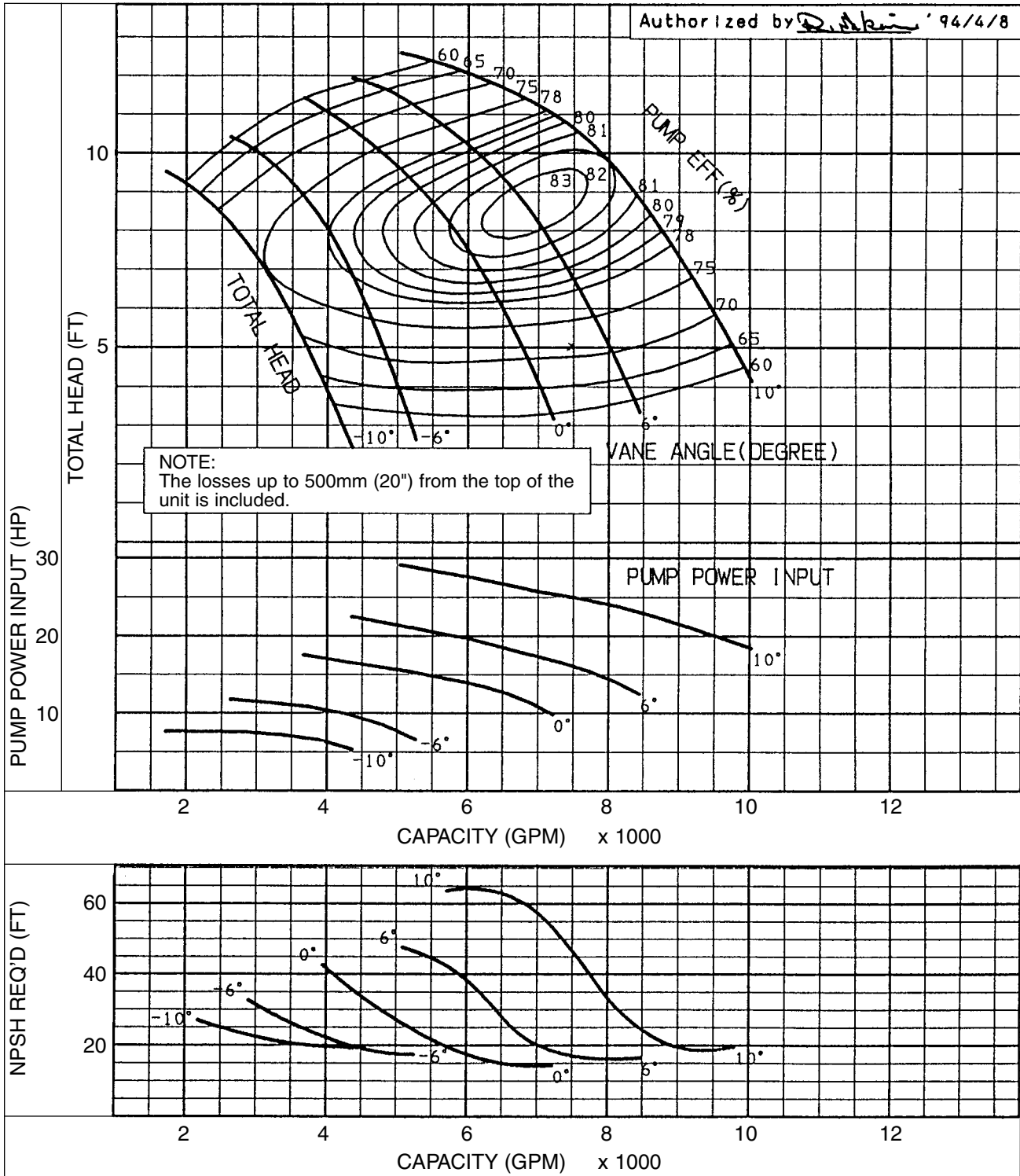

**Performance Curves**

Project:

Chk'd:

Date:

Curve No: A0713-710U Rev.0

**Model**

GPM

FT

RPM

HP

X

X

710

X

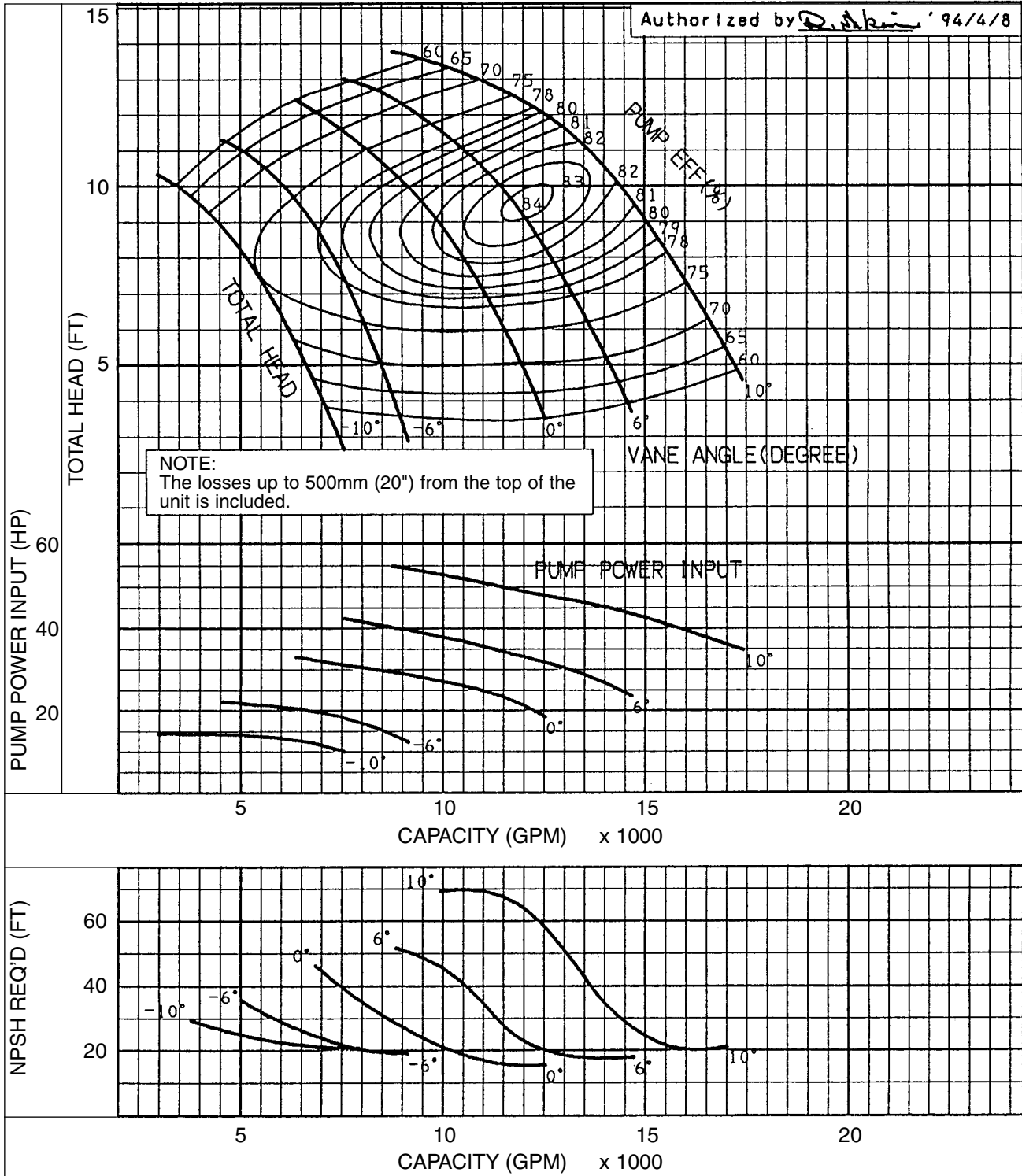

**Performance Curves**

Project:

Chk'd:

Date:

Curve No: A0843-710U Rev.0

Model	GPM	FT	RPM	HP
	X	X	710	X

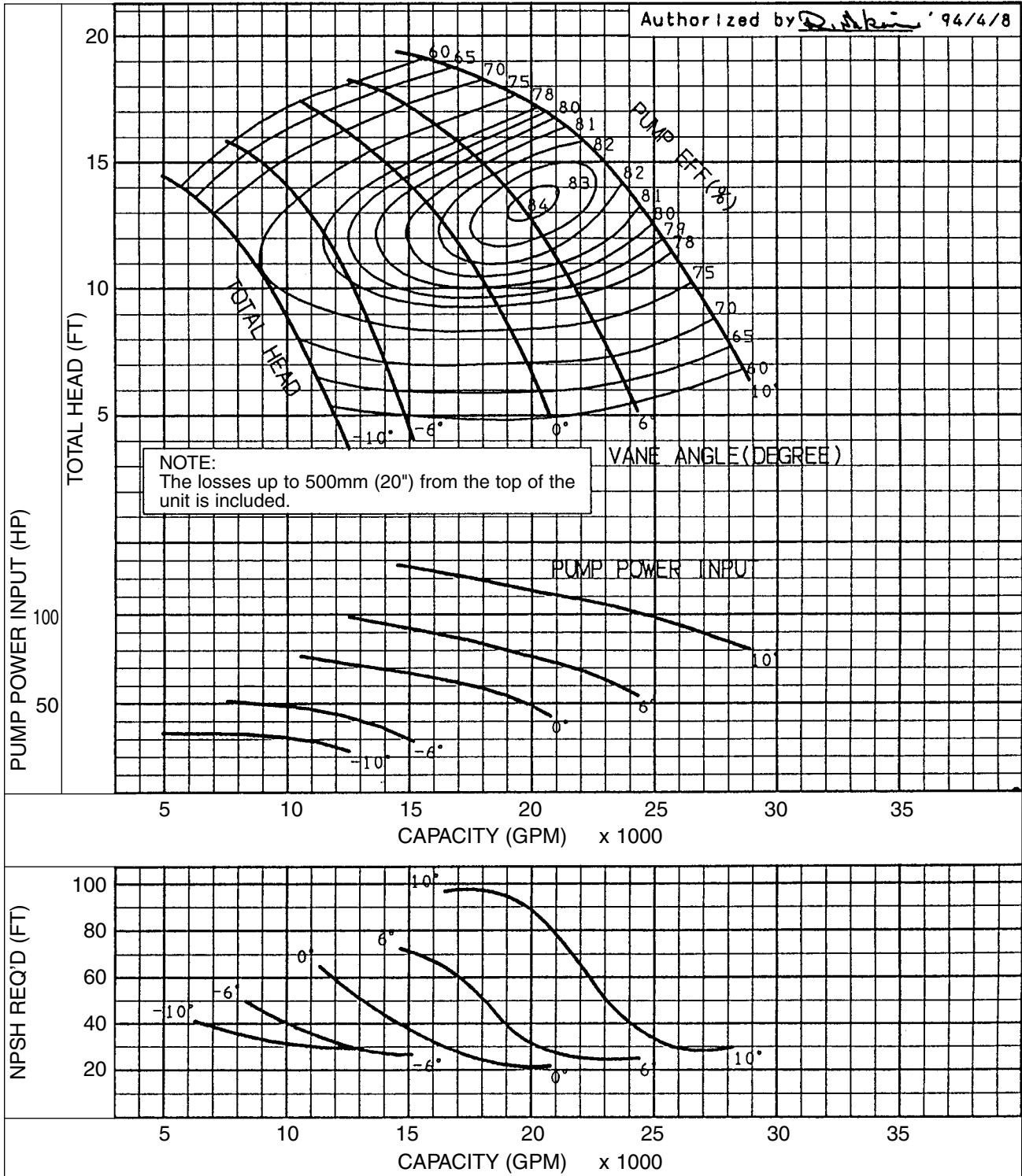

**Performance Curves**

Project:

Chk'd:

Date:

Curve No: A1003-593U Rev.0

Model	GPM	FT	RPM	HP
	X	X	593	X

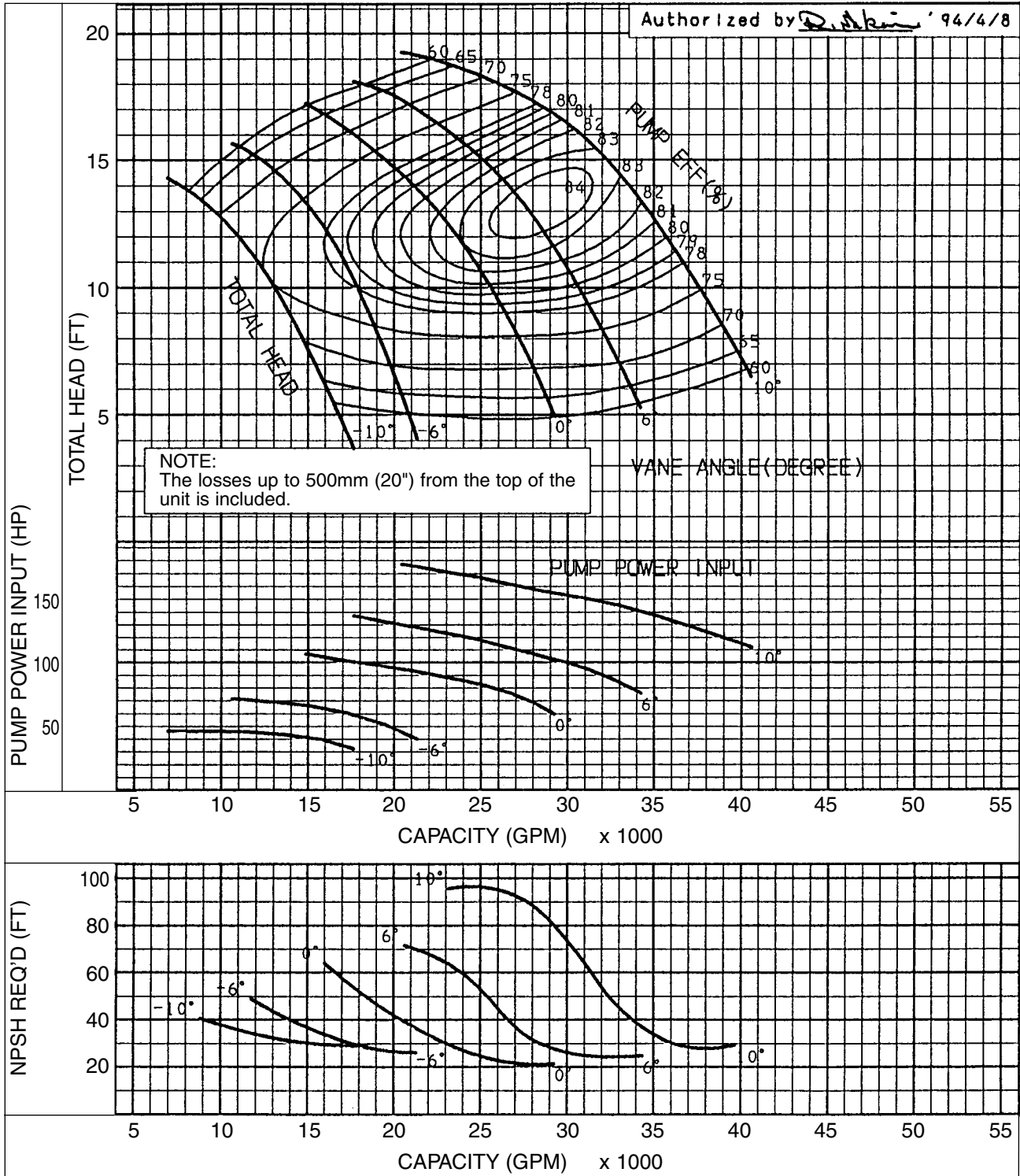



**Performance Curves**

Project:

Chk'd:

Date:

Curve No: C1125-1760U Rev.0

Model	GPM	FT	RPM	HP
	X	X	1760	X

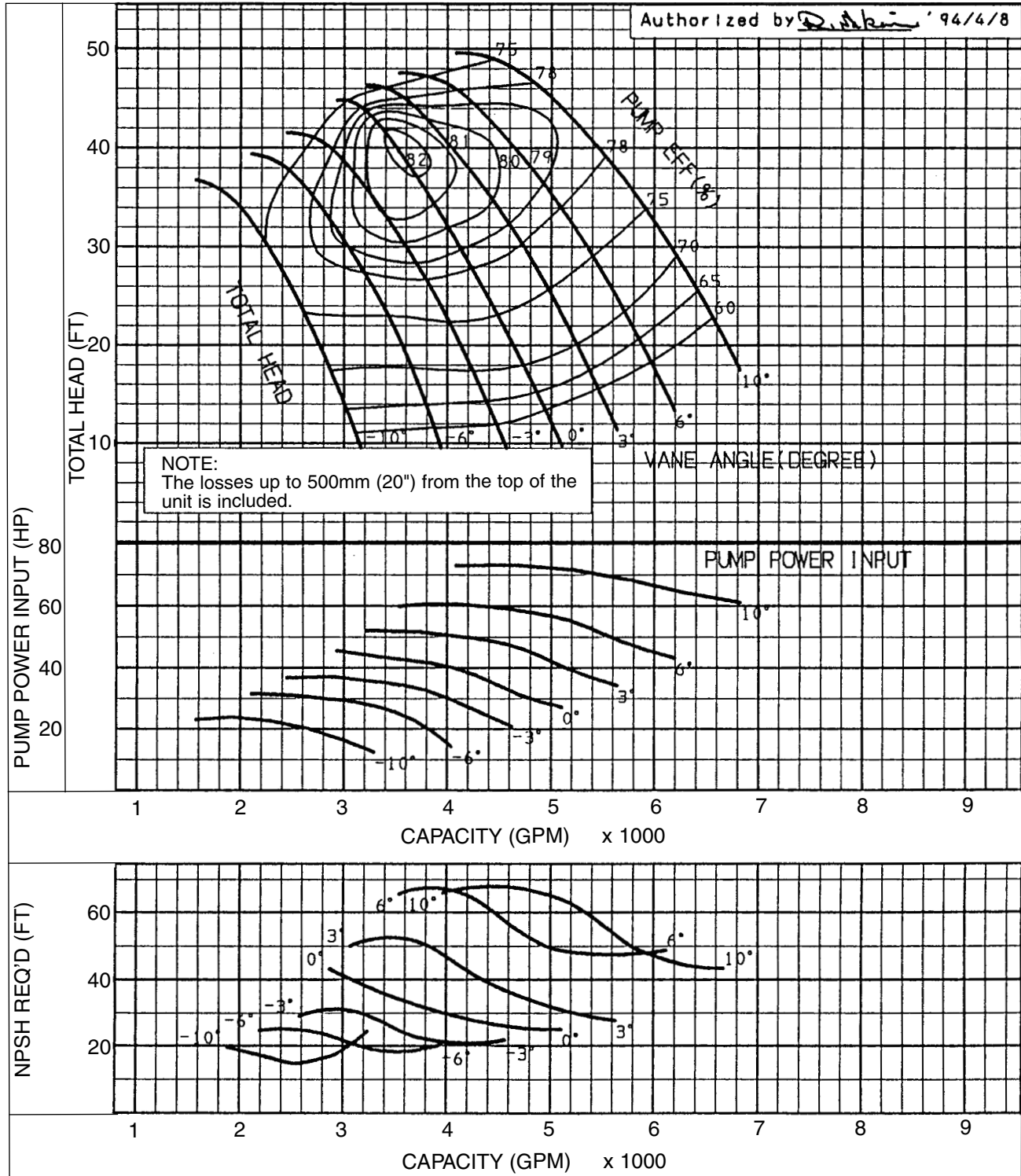



**Performance Curves**

Project:

Chk'd:

Date:

Curve No: C1455-1170U Rev.0

Model	GPM	FT	RPM	HP
	X	X	1170	X

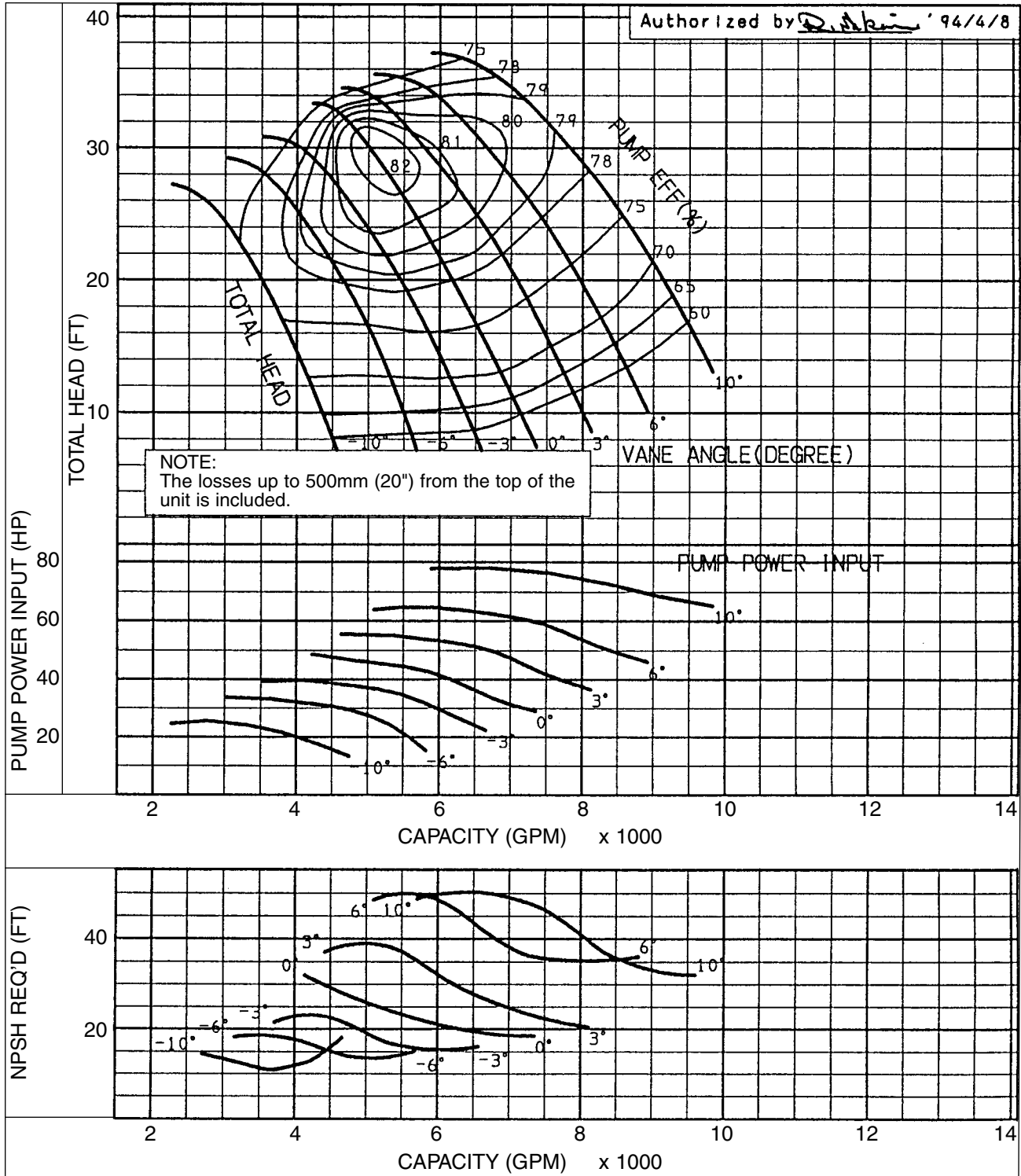

**Performance Curves**

Project:

Chk'd:

Date:

Curve No: C1605-1170U Rev.0

Model	GPM	FT	RPM	HP
	X	X	1170	X

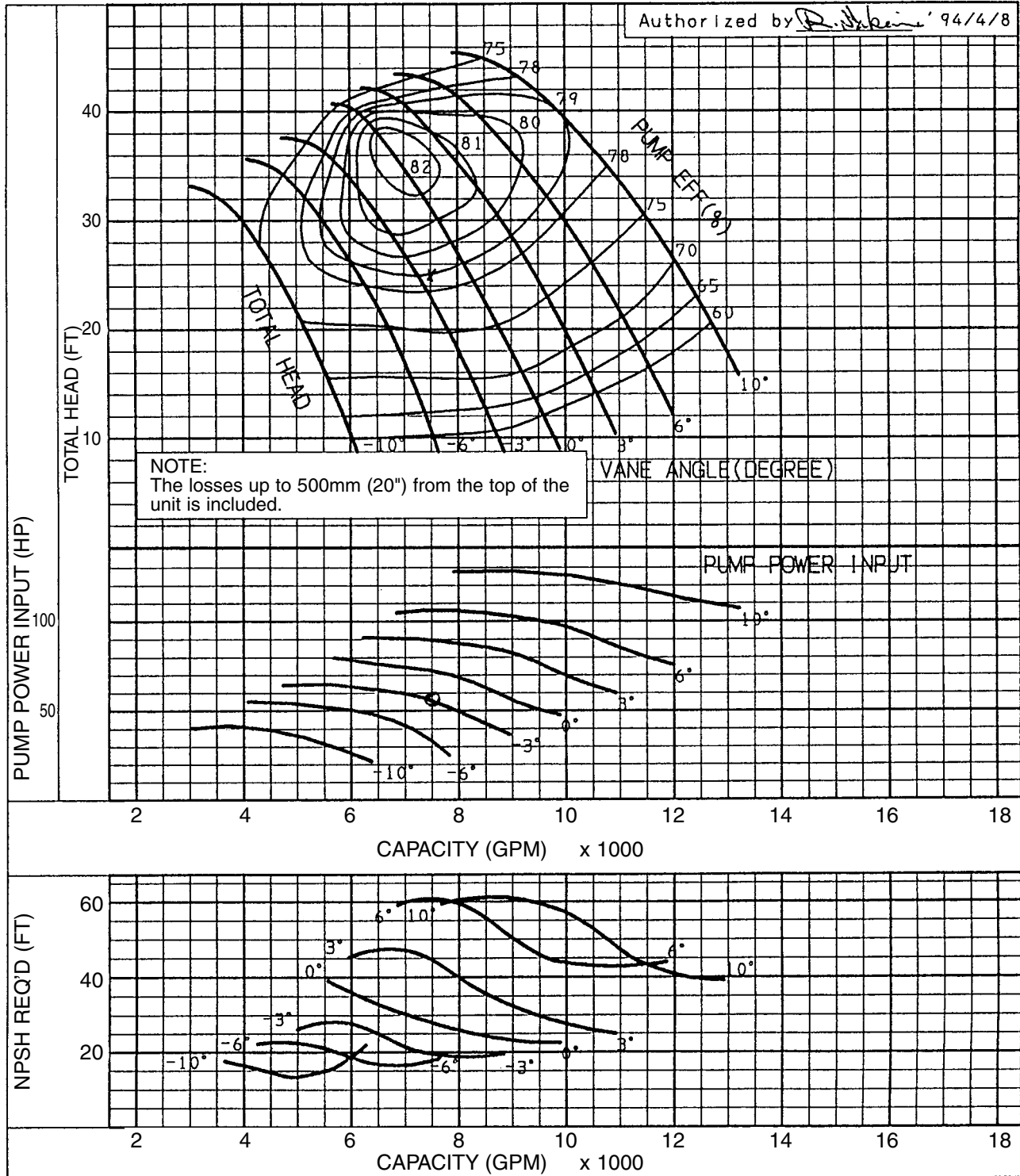

**Performance Curves**

Project:

Chk'd:

Date:

Curve No: C2185-885U Rev.0

Model	GPM	FT	RPM	HP
	X	X	885	X

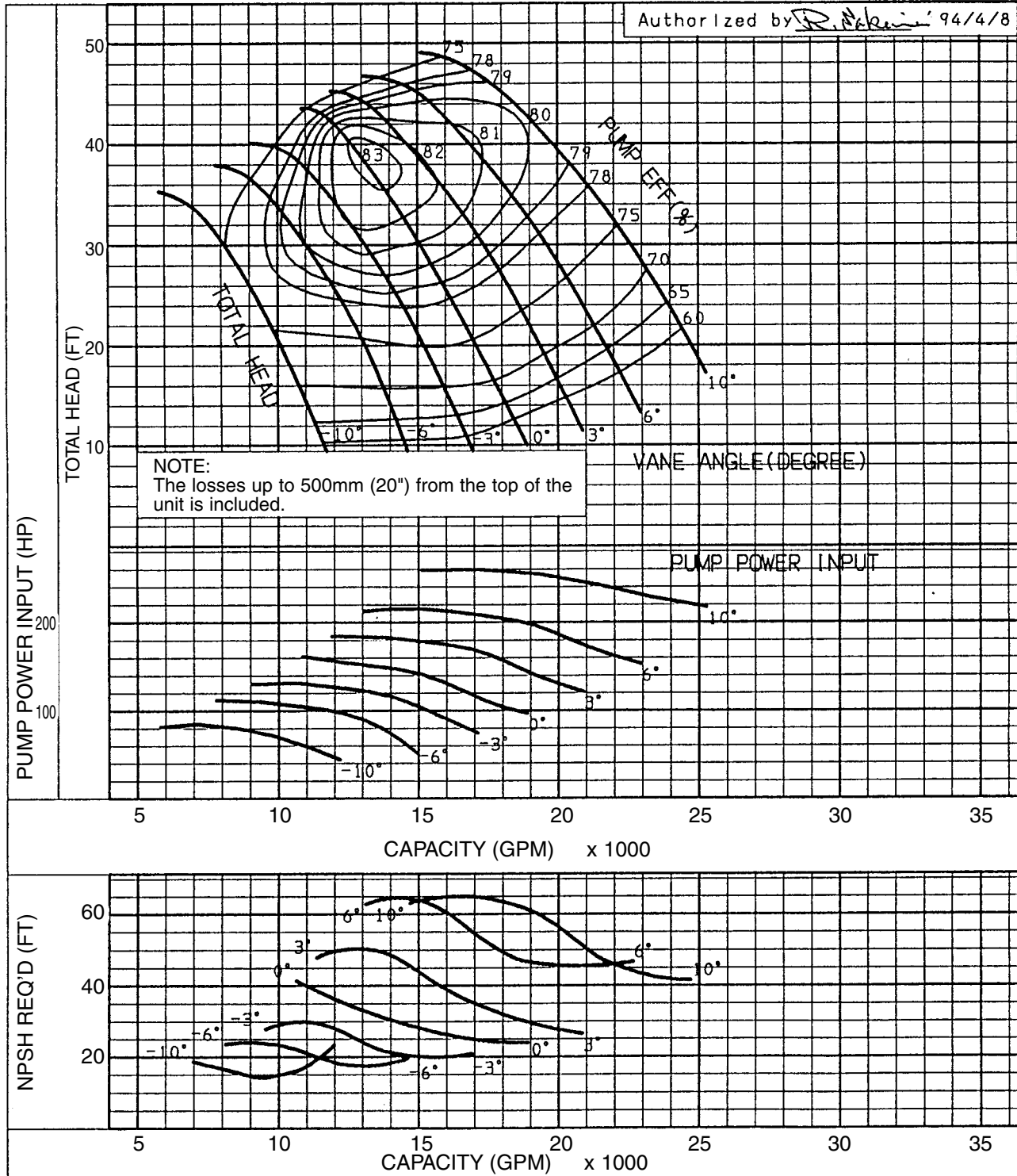

**Performance Curves**

Project:

Chk'd:

Date:

Curve No: C2905-710U Rev.0

Model	GPM	FT	RPM	HP
	X	X	710	X

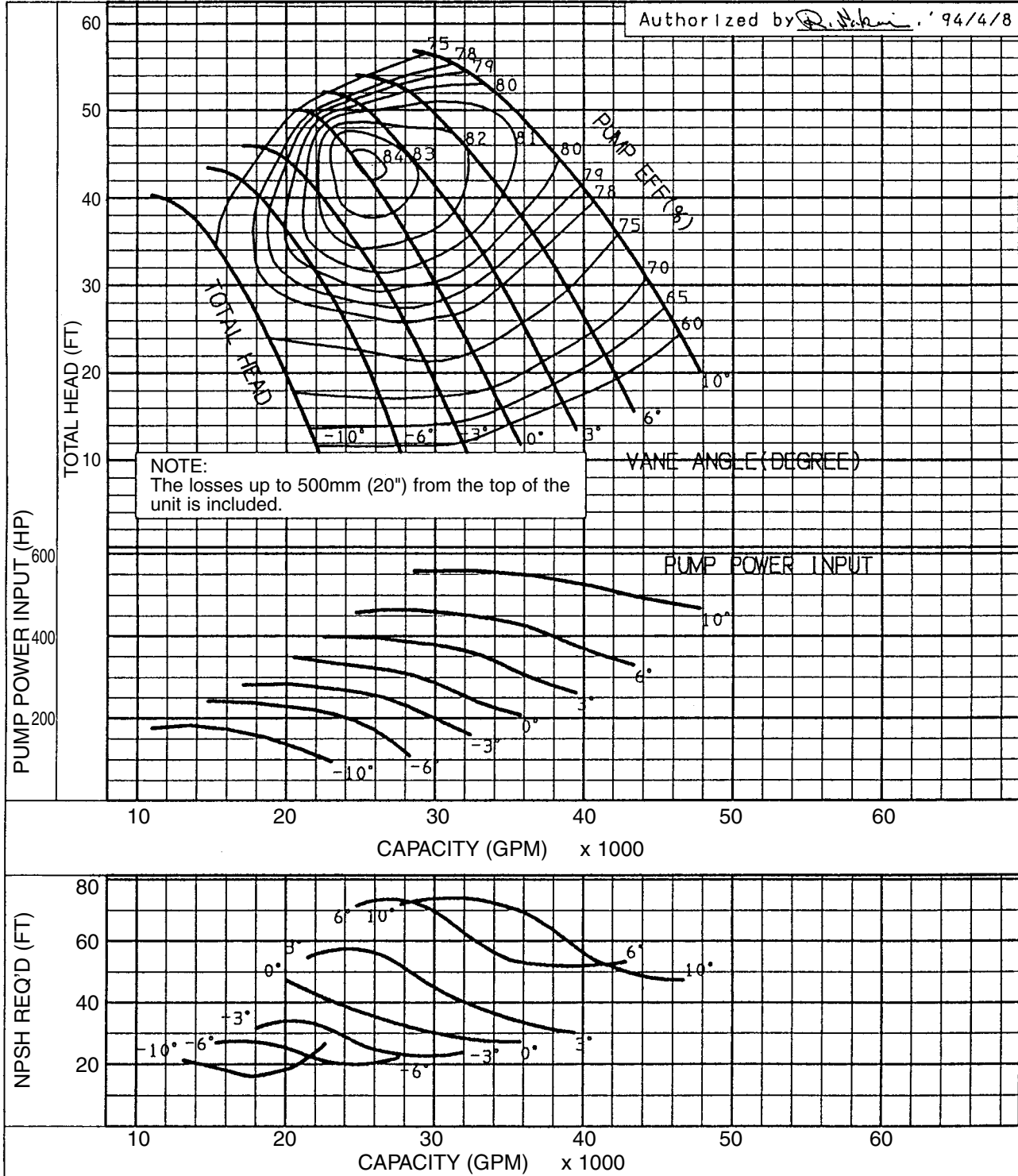

**Performance Curves**

Project:

Chk'd:

Date:

Curve No: V0494-880U Rev.0

**Model**

GPM

FT

RPM

HP

X

X

880

X

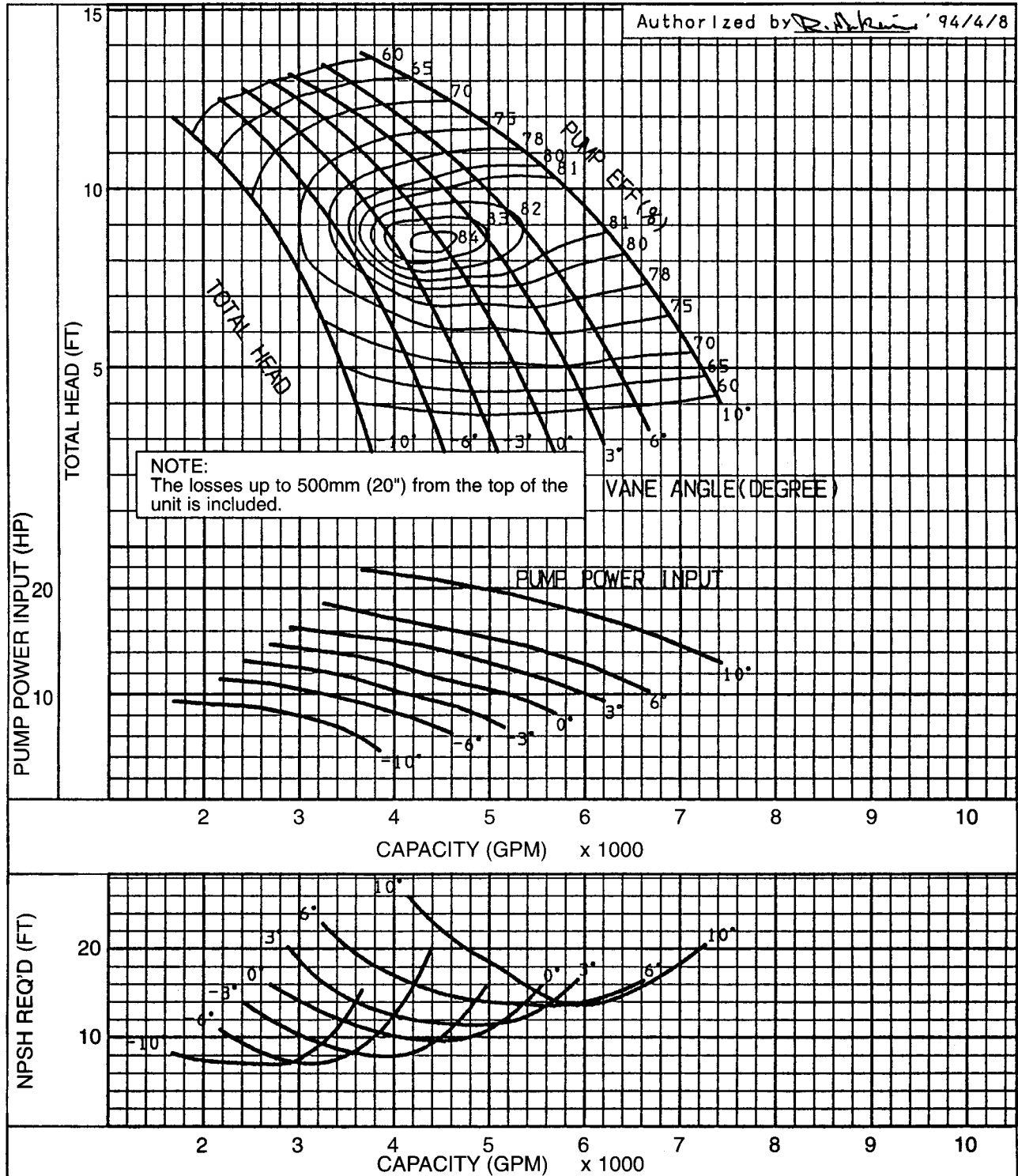



**Performance Curves**

Project:

Chk'd:

Date:

Curve No: V0494-1170U Rev.0

Model	GPM	FT	RPM	HP
	X	X	1170	X

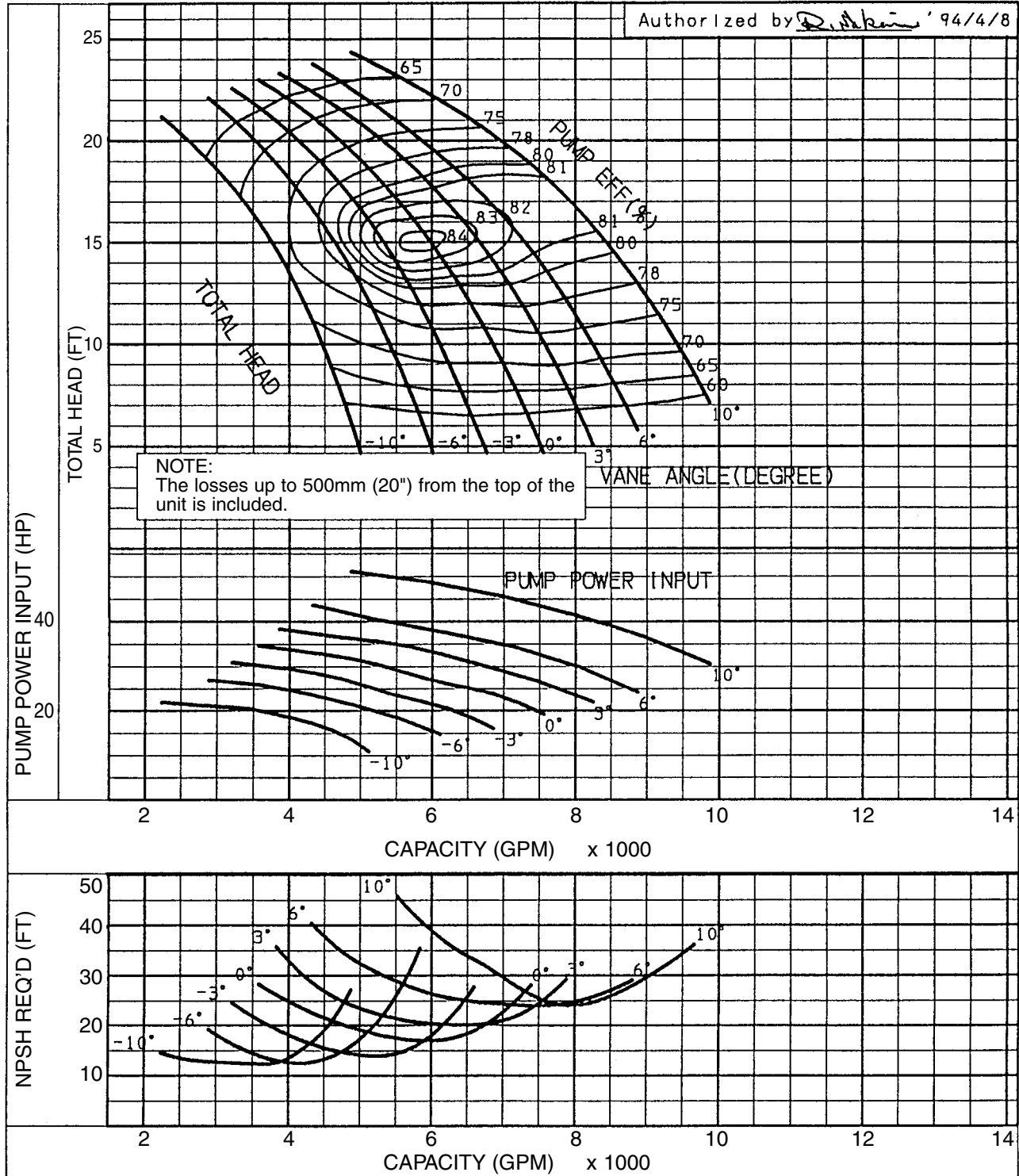

**Performance Curves**

Project:

Chk'd:

Date:

Curve No: V0554-880U Rev.0

Model	GPM	FT	RPM	HP
	X	X	880	X

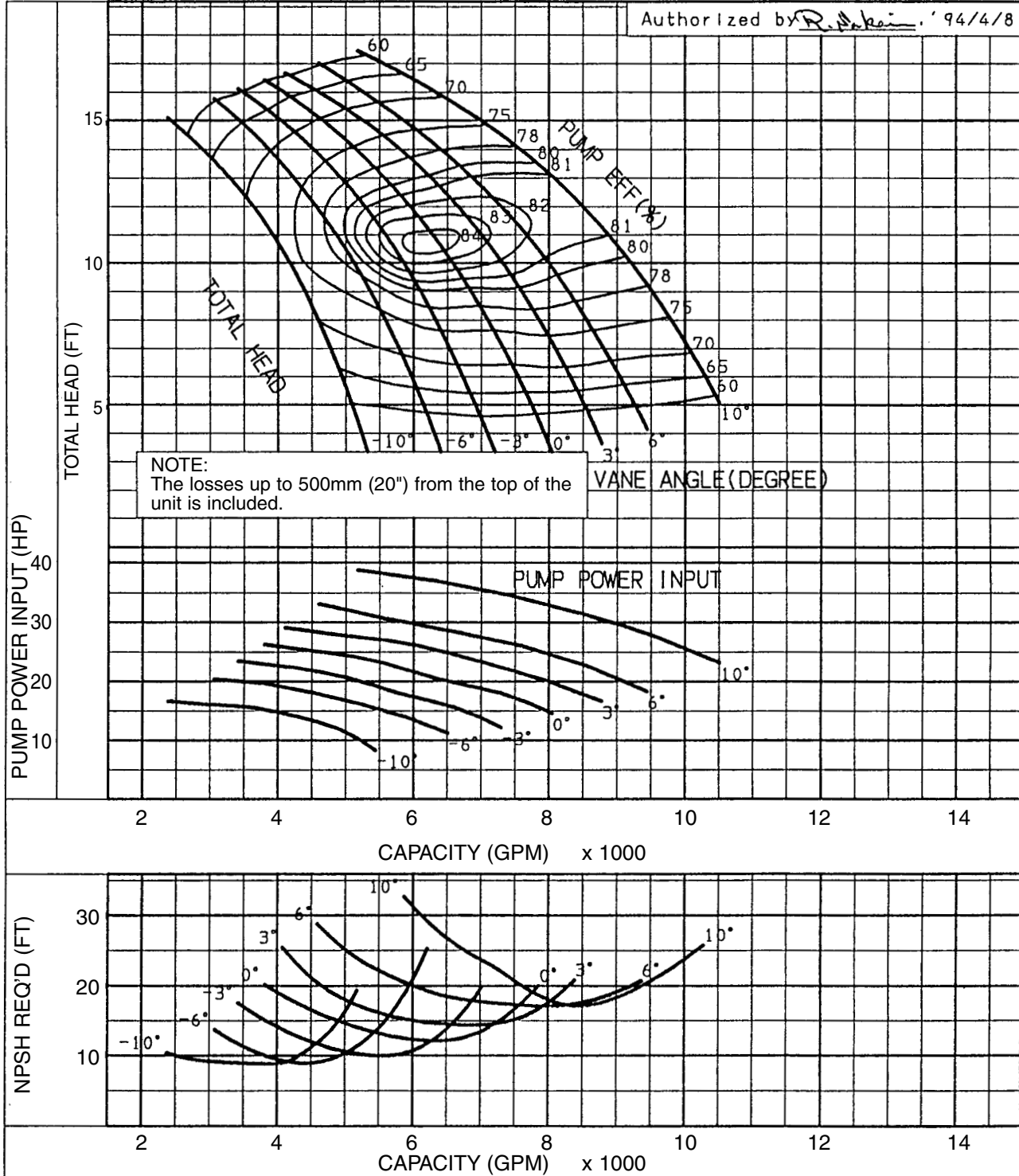

**Performance Curves**

Project:

Chk'd:

Date:

Curve No: V0554-1170U Rev.0

Model	GPM	FT	RPM	HP
	X	X	1170	X

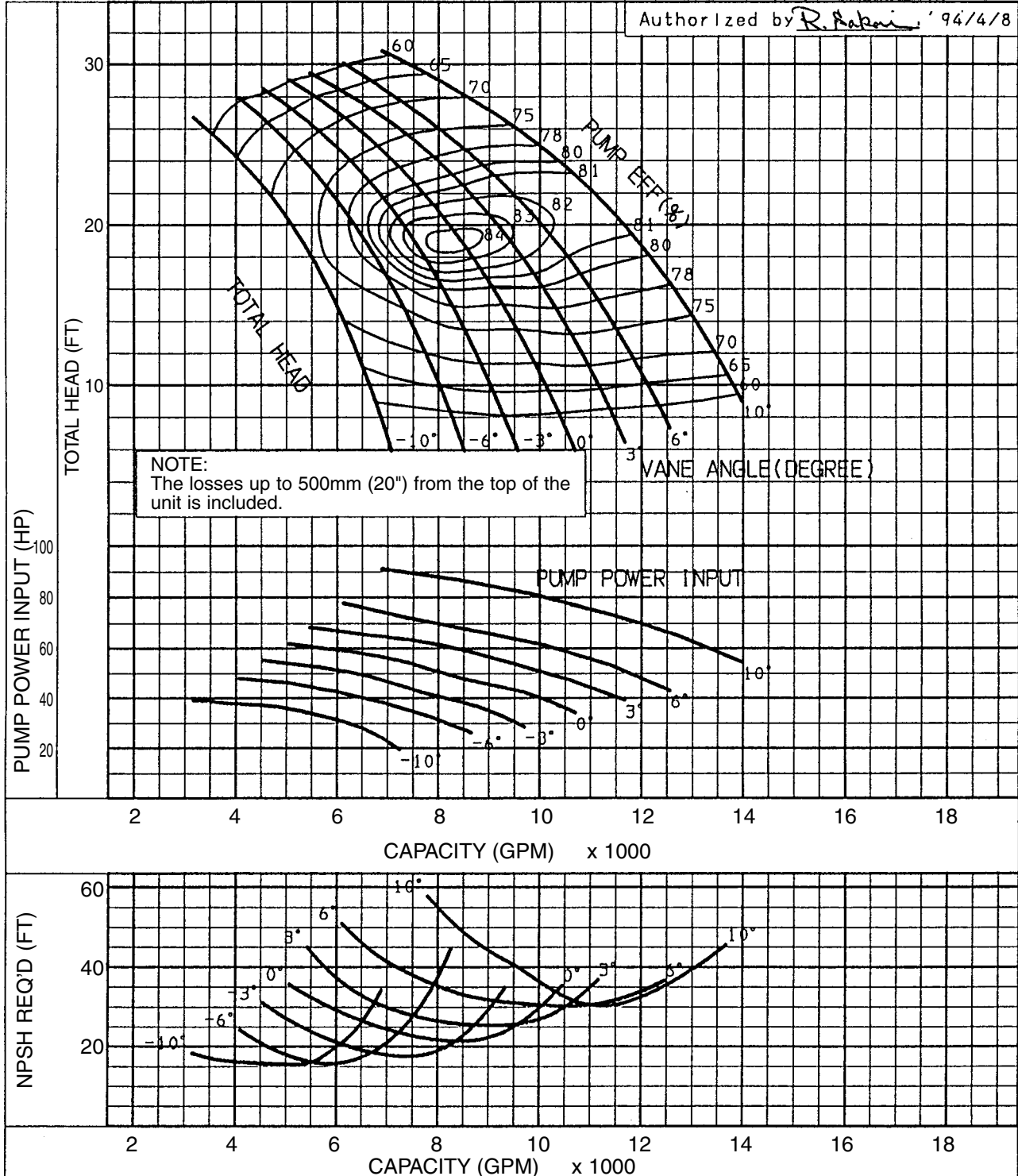



**Performance Curves**

Project:

Chk'd:

Date:

Curve No: V0754-710U Rev.0

Model	GPM	FT	RPM	HP
	X	X	710	X

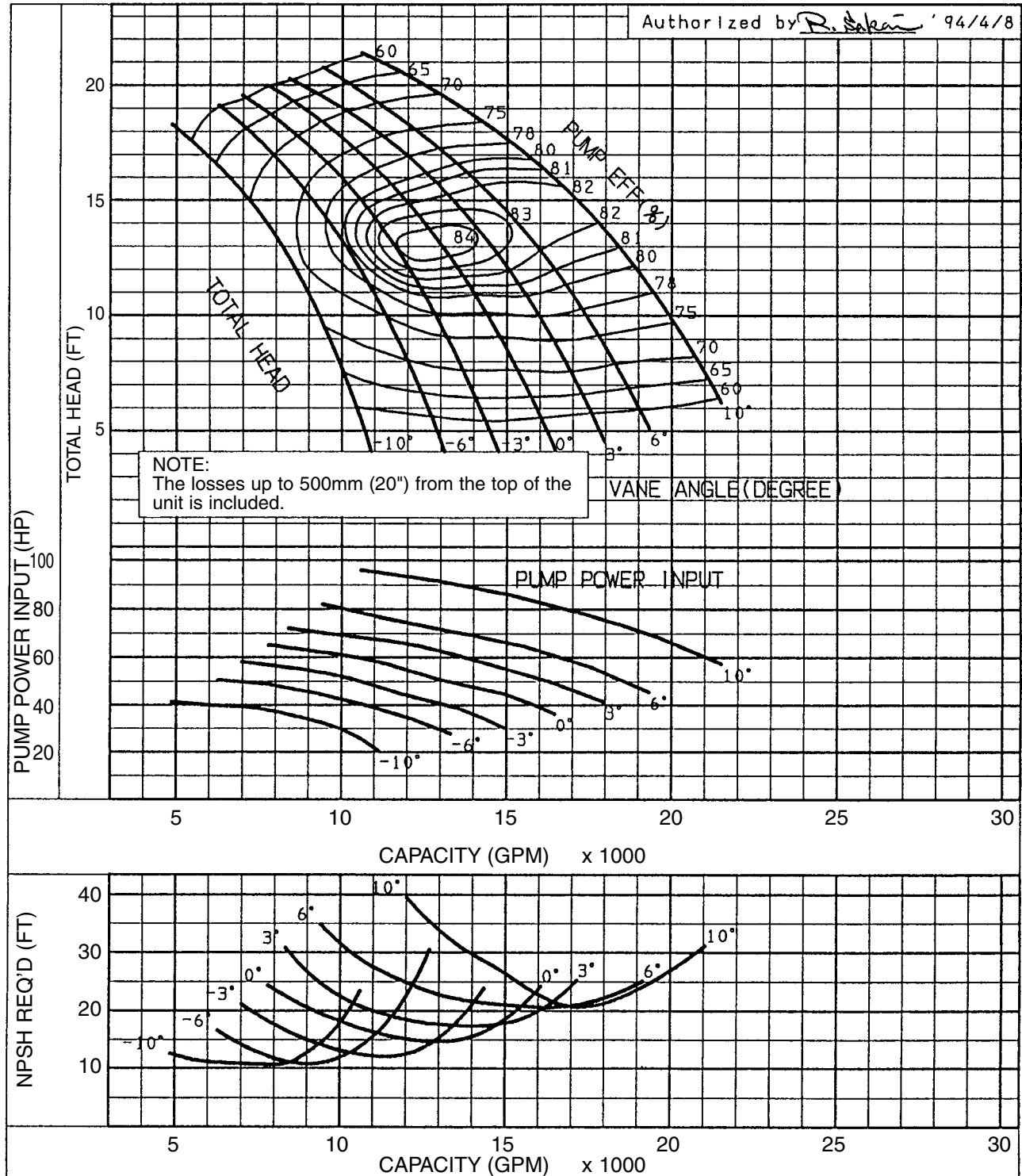

**Performance Curves**

Project:

Chk'd:

Date:

Curve No: V0754-885U Rev.0

Model	GPM	FT	RPM	HP
	X	X	885	X

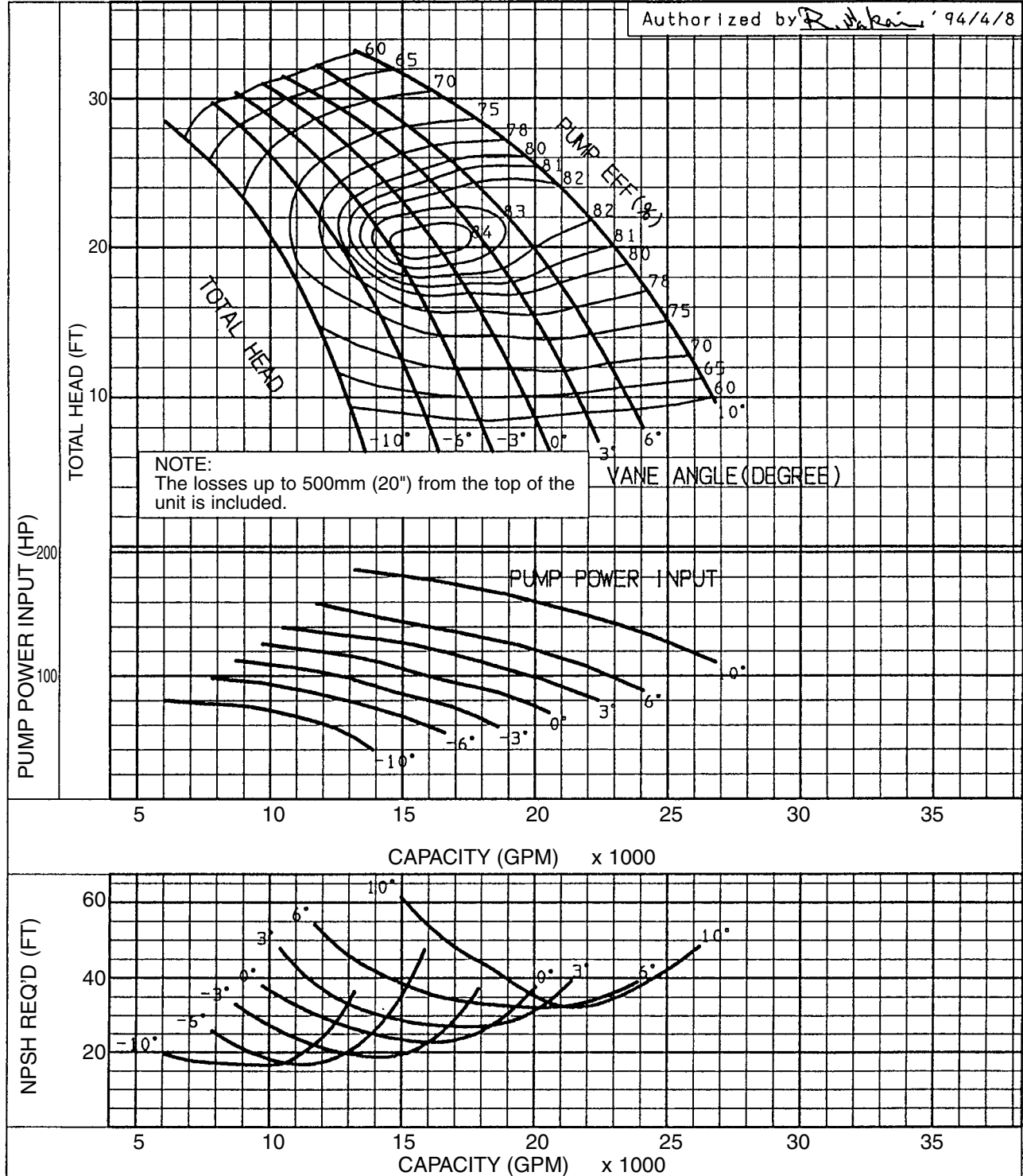

**Performance Curves**

Project:

Chk'd:

Date:

Curve No: V0854-710U Rev.0

Model	GPM	FT	RPM	HP
	X	X	710	X

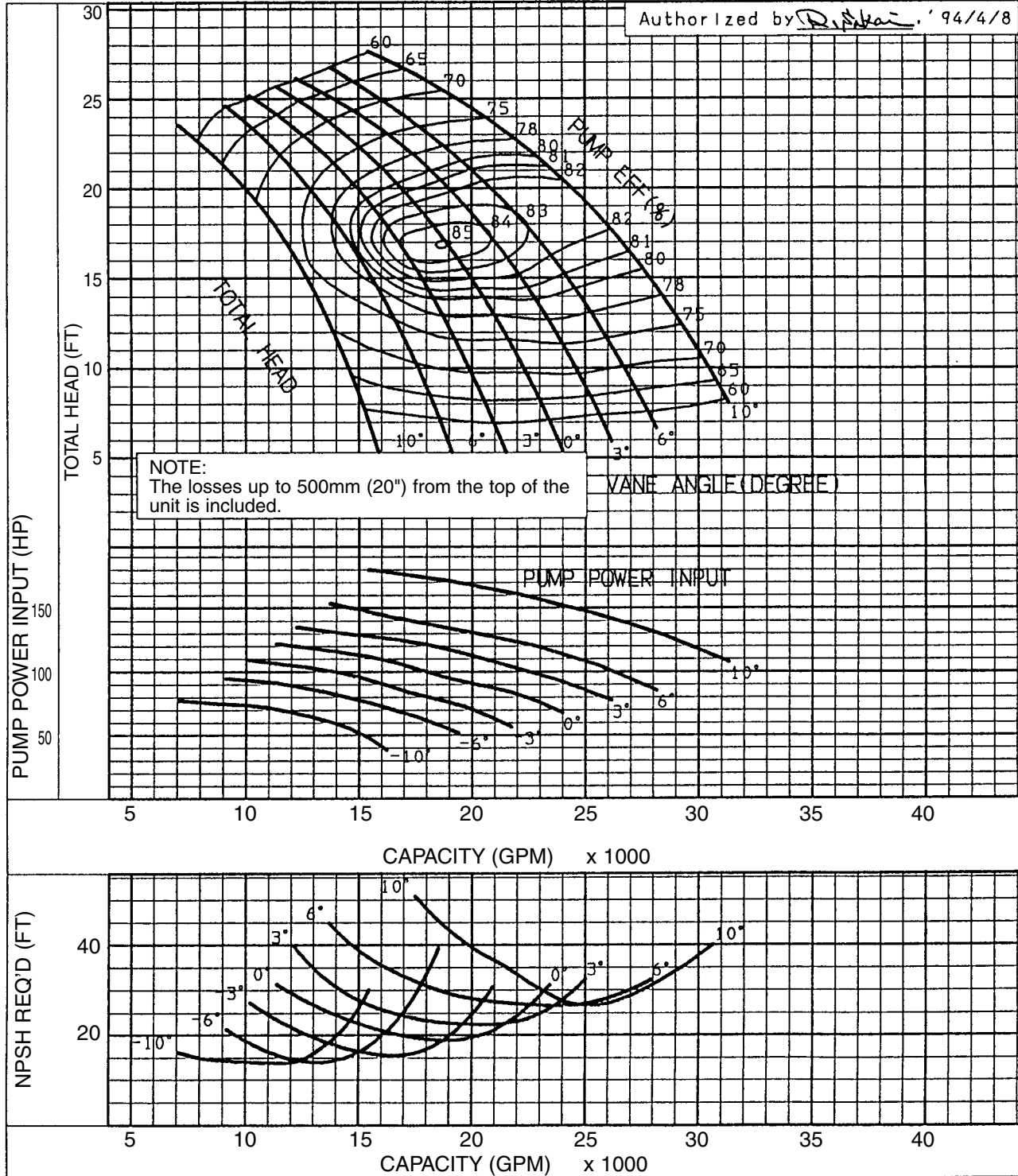

**Performance Curves**

Project:

Chk'd:

Date:

Curve No: V0974-710U Rev.0

**Model**

GPM

FT

RPM

HP

X

X

710

X

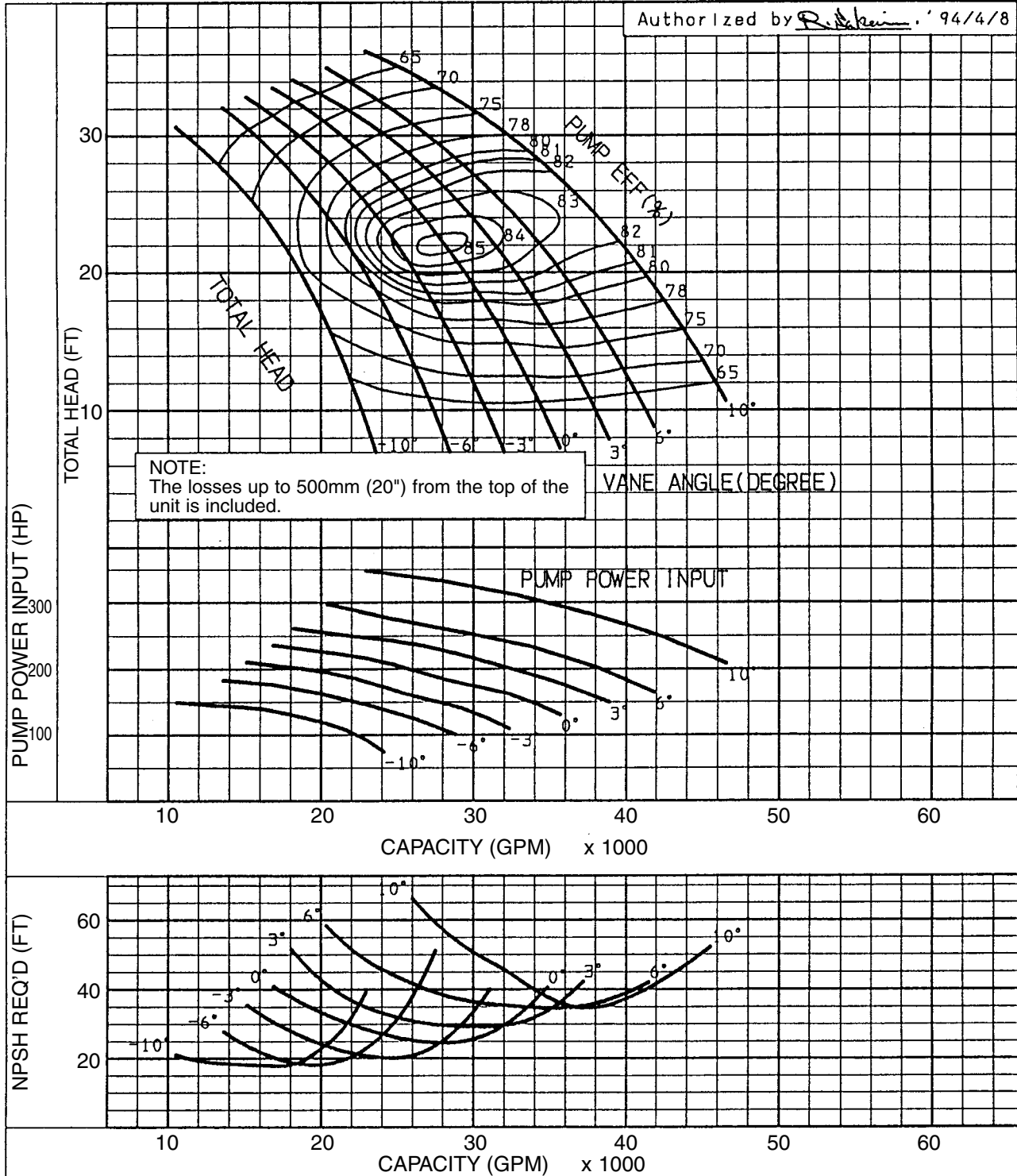

**Performance Curves**

Project:

Chk'd:

Date:

Curve No: V1154-593U Rev.0

Model	GPM	FT	RPM	HP
	X	X	593	X

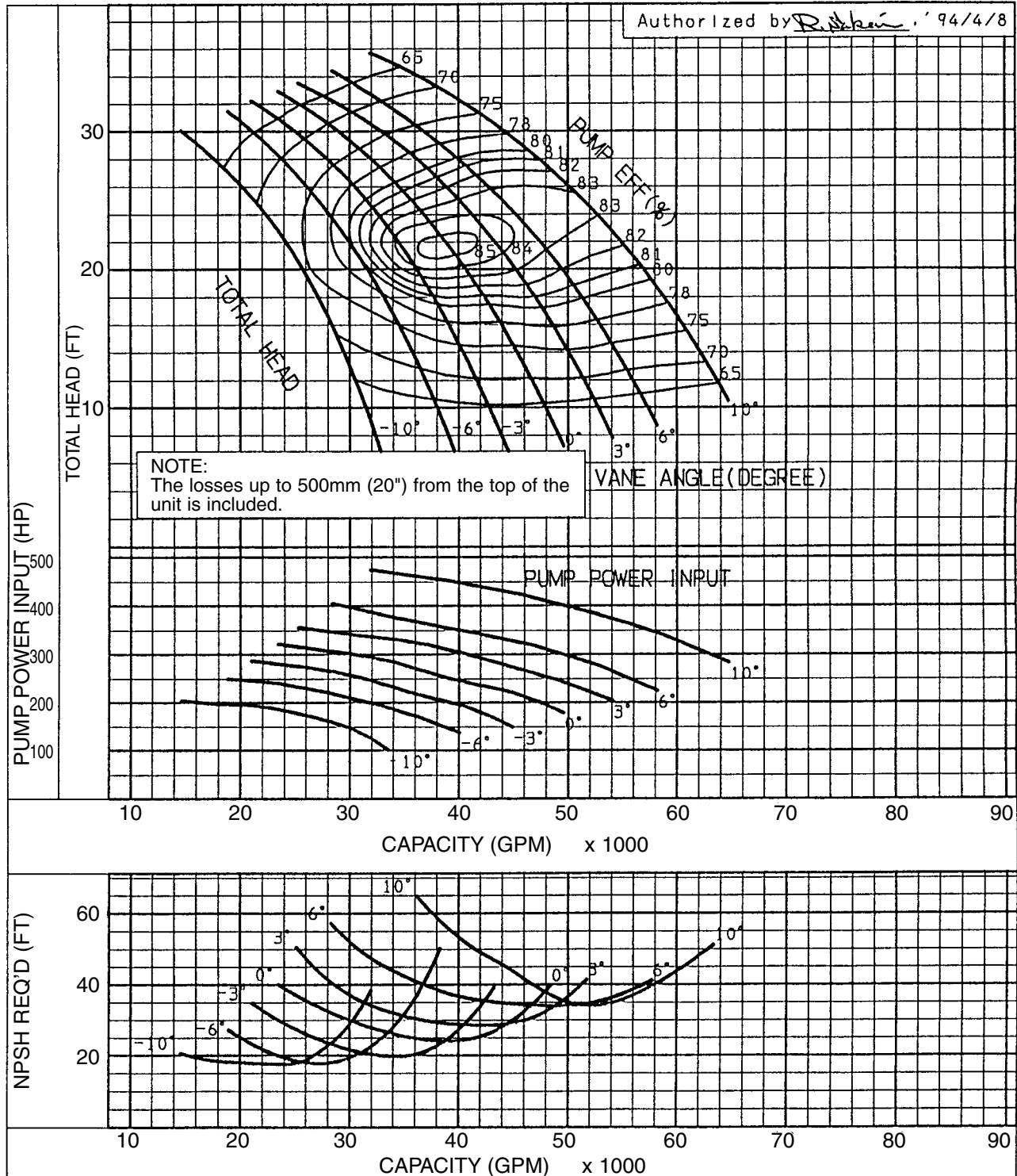



**Dimensions**

Project: \_\_\_\_\_ Model: \_\_\_\_\_ Chk'd: \_\_\_\_\_ Date: \_\_\_\_\_

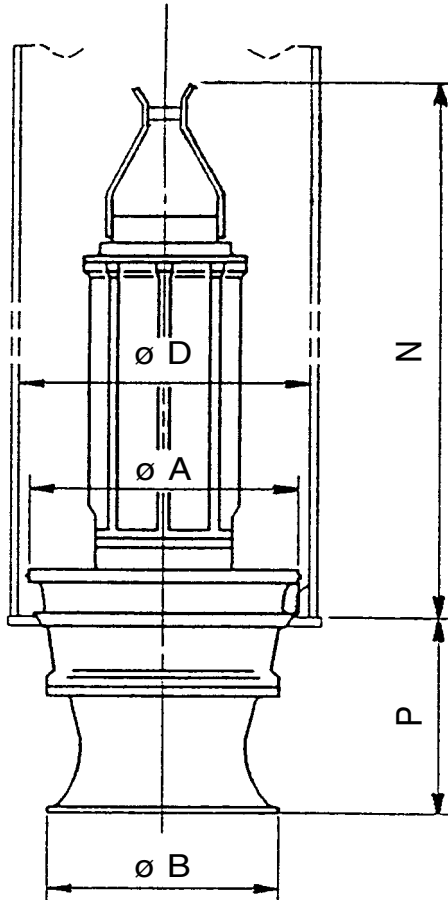
**Apply to Model A0553, A0713, A0843, A1003**

**Dimensions: inch**

Model (Pole)	HP	Pump & Motor					Column Pipe Dia. D (†2)	Weight Lbs (†1)
		A (†2)	B	P	N			
A0553-880 (8 POLES)	10	Contact EBARA						
	15							
	20							
	25	26 <sup>3</sup> / <sub>4</sub>	21 <sup>1</sup> / <sub>4</sub>	16 <sup>1</sup> / <sub>8</sub>	58 <sup>1</sup> / <sub>4</sub>	28	1631	
A0713-710 (10 POLES)	25	34 <sup>5</sup> / <sub>8</sub>	24 <sup>13</sup> / <sub>16</sub>	19 <sup>11</sup> / <sub>16</sub>	70 <sup>1</sup> / <sub>2</sub>	36	2778	
	30	34 <sup>5</sup> / <sub>8</sub>	24 <sup>13</sup> / <sub>16</sub>	19 <sup>11</sup> / <sub>16</sub>	70 <sup>1</sup> / <sub>2</sub>	36	2778	
	40	34 <sup>5</sup> / <sub>8</sub>	24 <sup>13</sup> / <sub>16</sub>	19 <sup>11</sup> / <sub>16</sub>	70 <sup>1</sup> / <sub>2</sub>	36	2866	
	50	34 <sup>5</sup> / <sub>8</sub>	24 <sup>13</sup> / <sub>16</sub>	19 <sup>11</sup> / <sub>16</sub>	70 <sup>1</sup> / <sub>2</sub>	36	2932	
A0843-710 (10 POLES)	50	34 <sup>5</sup> / <sub>8</sub>	28 <sup>3</sup> / <sub>4</sub>	20 <sup>11</sup> / <sub>16</sub>	72 <sup>13</sup> / <sub>16</sub>	36	3175	
	60	34 <sup>5</sup> / <sub>8</sub>	28 <sup>3</sup> / <sub>4</sub>	20 <sup>11</sup> / <sub>16</sub>	78 <sup>3</sup> / <sub>4</sub>	36	3395	
	75	40 <sup>9</sup> / <sub>16</sub>	28 <sup>3</sup> / <sub>4</sub>	25 <sup>9</sup> / <sub>16</sub>	74	42	3770	
A1003-593 (12 POLES)	100	40 <sup>9</sup> / <sub>16</sub>	28 <sup>3</sup> / <sub>4</sub>	25 <sup>9</sup> / <sub>16</sub>	87 <sup>3</sup> / <sub>8</sub>	42	4696	
	75	40 <sup>9</sup> / <sub>16</sub>	34 <sup>1</sup> / <sub>4</sub>	23 <sup>5</sup> / <sub>8</sub>	90 <sup>15</sup> / <sub>16</sub>	42	5137	
	100	46 <sup>7</sup> / <sub>16</sub>	34 <sup>1</sup> / <sub>4</sub>	24 <sup>13</sup> / <sub>16</sub>	89 <sup>3</sup> / <sub>4</sub>	48	5622	
	120	46 <sup>7</sup> / <sub>16</sub>	34 <sup>1</sup> / <sub>4</sub>	24 <sup>13</sup> / <sub>16</sub>	93 <sup>11</sup> / <sub>16</sub>	48	5930	

**Dimensions: mm**

Model (Pole)	KW	Pump & Motor					Column Pipe Dia. D (†2)	Weight kgf (†1)
		A (†2)	B	P	N			
A0553-880 (8 POLES)	7.5	Contact EBARA						
	11							
	15							
	18.5	680	540	410	1480	700	740	
A0713-710 (10 POLES)	18.5	880	630	500	1790	900	1260	
	22	880	630	500	1790	900	1260	
	30	880	630	500	1790	900	1300	
	37	880	630	500	1790	900	1330	
A0843-710 (10 POLES)	37	880	730	525	1850	900	1440	
	45	880	730	525	2000	900	1540	
	55	1030	730	650	1880	1050	1710	
A1003-593 (12 POLES)	75	1030	730	650	2220	1050	2130	
	55	1030	870	600	2310	1050	2330	
	75	1180	870	630	2280	1200	2550	
	90	1180	870	630	2380	1200	2690	

**Dimensions are Approximate**

Note:

†1 Includes weight of 33 ft. standard length cables.

†2 Consult EBARA if smaller diameter is required.

**Dimensions**

Project: \_\_\_\_\_ Model: \_\_\_\_\_ Chk'd: \_\_\_\_\_ Date: \_\_\_\_\_

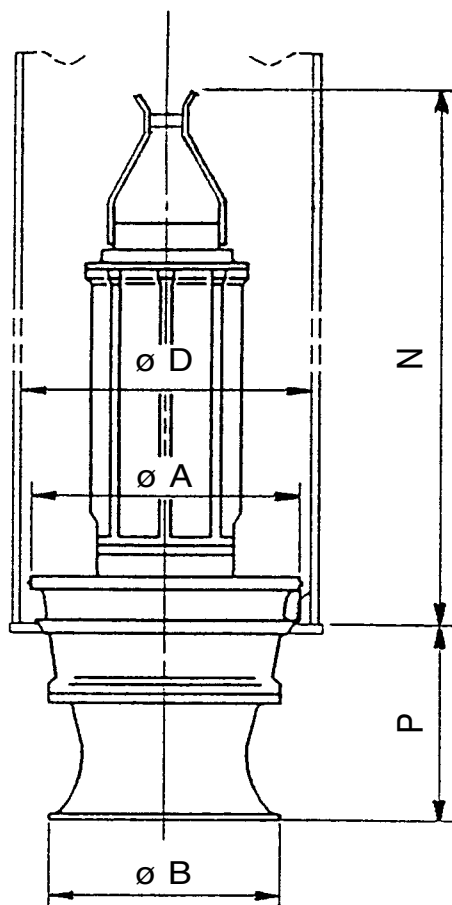
**Apply to Model C1125, C1455, C1605 C2185, C2905**

**Dimensions: inch**

Model (Pole)	HP	Pump & Motor					Column Pipe Dia. D	Weight Lbs (*1)
		A	B	P	N			
C1125-1760 (4 POLES)	30	Contact EBARA						
	40	Contact EBARA						
	50	22 <sup>13</sup> / <sub>16</sub>	15 <sup>3</sup> / <sub>4</sub>	14 <sup>9</sup> / <sub>16</sub>	57 <sup>1</sup> / <sub>2</sub>	24	1433	
C1455-1170 (6 POLES)	30	Contact EBARA						
	40	22 <sup>13</sup> / <sub>16</sub>	18 <sup>1</sup> / <sub>8</sub>	15 <sup>3</sup> / <sub>16</sub>	59 <sup>1</sup> / <sub>16</sub>	24	1543	
	50	22 <sup>13</sup> / <sub>16</sub>	18 <sup>1</sup> / <sub>8</sub>	15 <sup>3</sup> / <sub>16</sub>	59 <sup>1</sup> / <sub>16</sub>	24	1587	
C1605-1170 (6 POLES)	60	22 <sup>13</sup> / <sub>16</sub>	18 <sup>1</sup> / <sub>8</sub>	15 <sup>3</sup> / <sub>16</sub>	62 <sup>3</sup> / <sub>16</sub>	24	1653	
	75	26 <sup>3</sup> / <sub>4</sub>	21 <sup>1</sup> / <sub>4</sub>	17 <sup>1</sup> / <sub>2</sub>	62 <sup>5</sup> / <sub>8</sub>	28	1896	
	100	26 <sup>3</sup> / <sub>4</sub>	21 <sup>1</sup> / <sub>4</sub>	17 <sup>1</sup> / <sub>2</sub>	70 <sup>1</sup> / <sub>2</sub>	28	2646	
C2185-885 (8 POLES)	100	34 <sup>5</sup> / <sub>8</sub>	28 <sup>3</sup> / <sub>4</sub>	23 <sup>5</sup> / <sub>8</sub>	76	36	3660	
	120	34 <sup>5</sup> / <sub>8</sub>	28 <sup>3</sup> / <sub>4</sub>	23 <sup>5</sup> / <sub>8</sub>	89	36	4475	
	145	34 <sup>5</sup> / <sub>8</sub>	28 <sup>3</sup> / <sub>4</sub>	23 <sup>5</sup> / <sub>8</sub>	89	36	4630	
C2905-710 (10 POLES)	175	38 <sup>9</sup> / <sub>16</sub>	28 <sup>3</sup> / <sub>4</sub>	23 <sup>5</sup> / <sub>8</sub>	89	40	4982	
	200	46 <sup>7</sup> / <sub>16</sub>	39 <sup>3</sup> / <sub>8</sub>	31 <sup>11</sup> / <sub>16</sub>	89 <sup>3</sup> / <sub>4</sub>	48	8400	
	215	46 <sup>7</sup> / <sub>16</sub>	39 <sup>3</sup> / <sub>8</sub>	31 <sup>11</sup> / <sub>16</sub>	89 <sup>3</sup> / <sub>4</sub>	48	8422	
	245	46 <sup>7</sup> / <sub>16</sub>	39 <sup>3</sup> / <sub>8</sub>	31 <sup>11</sup> / <sub>16</sub>	97 <sup>5</sup> / <sub>8</sub>	48	8730	
	265	46 <sup>7</sup> / <sub>16</sub>	39 <sup>3</sup> / <sub>8</sub>	31 <sup>11</sup> / <sub>16</sub>	97 <sup>5</sup> / <sub>8</sub>	48	8907	
	295	46 <sup>7</sup> / <sub>16</sub>	39 <sup>3</sup> / <sub>8</sub>	31 <sup>11</sup> / <sub>16</sub>	97 <sup>5</sup> / <sub>8</sub>	48	8929	
	335	46 <sup>7</sup> / <sub>16</sub>	39 <sup>3</sup> / <sub>8</sub>	31 <sup>11</sup> / <sub>16</sub>	97 <sup>5</sup> / <sub>8</sub>	48	9348	

**Dimensions: mm**

Model (Pole)	KW	Pump & Motor					Column Pipe Dia. D	Weight kgf (*1)
		A	B	P	N			
C1125-1760 (4 POLES)	22	Contact EBARA						
	30	Contact EBARA						
	37	580	400	370	1460	600	650	
C1455-1170 (6 POLES)	22	Contact EBARA						
	30	580	460	385	1500	600	700	
	37	580	460	385	1500	600	720	
C1605-1170 (6 POLES)	45	580	460	385	1580	600	750	
	45	680	540	445	1590	700	860	
	55	680	540	445	1590	700	860	
C2185-885 (8 POLES)	75	680	540	445	1790	700	1200	
	75	880	730	600	1930	900	1660	
	90	880	730	600	2260	900	2030	
C2905-710 (10 POLES)	110	880	730	600	2260	900	2100	
	132	980	730	600	2260	1000	2260	
	150	1180	1000	805	2280	1200	3810	
C2905-710 (10 POLES)	160	1180	1000	805	2280	1200	3820	
	185	1180	1000	805	2480	1200	3960	
	200	1180	1000	805	2480	1200	4040	
	220	1180	1000	805	2480	1200	4050	
	250	1180	1000	805	2480	1200	4240	

**Dimensions are Approximate**

Note:

\*1 Includes weight of 33 ft. standard length cables.

**Dimensions**

Project: \_\_\_\_\_ Model: \_\_\_\_\_ Chk'd: \_\_\_\_\_ Date: \_\_\_\_\_

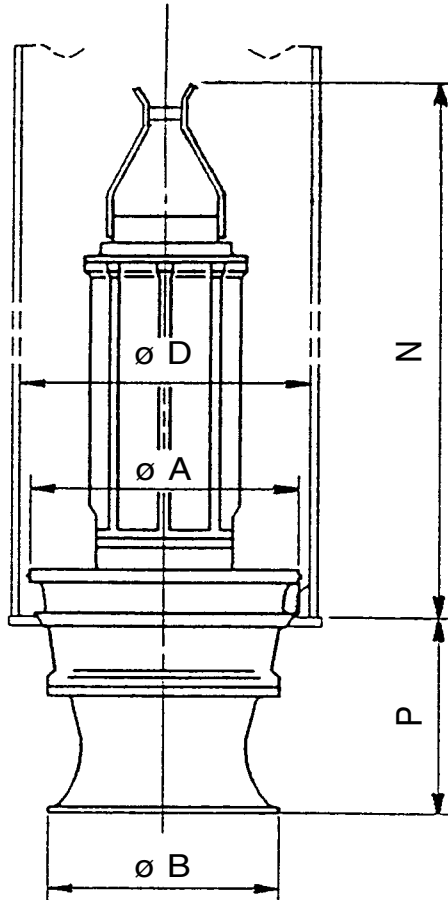
**Apply to Model V0494, V0554, V0754**

**Dimensions: inch**

Model (Pole)	HP	Pump & Motor					Column Pipe Dia. D (†2)	Weight Lbs (†1)
		A (†2)	B	P	N			
V0494-1170 (6 POLES)	25	Contact EBARA						
	30	Contact EBARA						
	40	26 <sup>3</sup> / <sub>4</sub>	18 <sup>1</sup> / <sub>8</sub>	17 <sup>11</sup> / <sub>16</sub>	55 <sup>1</sup> / <sub>8</sub>	28	1675	
	50	26 <sup>3</sup> / <sub>4</sub>	18 <sup>1</sup> / <sub>8</sub>	17 <sup>11</sup> / <sub>16</sub>	55 <sup>1</sup> / <sub>8</sub>	28	1720	
V0494-880 (8 POLES)	10	Contact EBARA						
	15	Contact EBARA						
	20	Contact EBARA						
V0554-1170 (6 POLES)	50	26 <sup>3</sup> / <sub>4</sub>	21 <sup>1</sup> / <sub>4</sub>	15 <sup>3</sup> / <sub>8</sub>	58 <sup>1</sup> / <sub>4</sub>	28	1808	
	60	26 <sup>3</sup> / <sub>4</sub>	21 <sup>1</sup> / <sub>4</sub>	15 <sup>3</sup> / <sub>8</sub>	62 <sup>3</sup> / <sub>16</sub>	28	1874	
	75	26 <sup>3</sup> / <sub>4</sub>	21 <sup>1</sup> / <sub>4</sub>	15 <sup>3</sup> / <sub>8</sub>	62 <sup>3</sup> / <sub>16</sub>	28	1874	
V0554-880 (8 POLES)	20	Contact EBARA						
	25	26 <sup>3</sup> / <sub>4</sub>	21 <sup>1</sup> / <sub>4</sub>	15 <sup>3</sup> / <sub>8</sub>	58 <sup>1</sup> / <sub>4</sub>	28	1764	
	30	26 <sup>3</sup> / <sub>4</sub>	21 <sup>1</sup> / <sub>4</sub>	15 <sup>3</sup> / <sub>8</sub>	58 <sup>1</sup> / <sub>4</sub>	28	1808	
	40	26 <sup>3</sup> / <sub>4</sub>	21 <sup>1</sup> / <sub>4</sub>	15 <sup>3</sup> / <sub>8</sub>	62 <sup>3</sup> / <sub>16</sub>	28	1874	
V0754-885 (8 POLES)	100	34 <sup>5</sup> / <sub>8</sub>	27 <sup>9</sup> / <sub>16</sub>	20 <sup>1</sup> / <sub>4</sub>	77 <sup>9</sup> / <sub>16</sub>	36	3307	
	120	40 <sup>9</sup> / <sub>16</sub>	27 <sup>9</sup> / <sub>16</sub>	24 <sup>3</sup> / <sub>16</sub>	86 <sup>5</sup> / <sub>8</sub>	42	4497	
	145	40 <sup>9</sup> / <sub>16</sub>	27 <sup>9</sup> / <sub>16</sub>	24 <sup>3</sup> / <sub>16</sub>	86 <sup>5</sup> / <sub>8</sub>	42	4630	
	175	40 <sup>9</sup> / <sub>16</sub>	27 <sup>9</sup> / <sub>16</sub>	24 <sup>3</sup> / <sub>16</sub>	86 <sup>5</sup> / <sub>8</sub>	42	4784	

**Dimensions: mm**

Model (Pole)	KW	Pump & Motor					Column Pipe Dia. D (†2)	Weight kgf (†1)
		A (†2)	B	P	N			
V0494-1170 (6 POLES)	18.5	Contact EBARA						
	22	Contact EBARA						
	30	680	460	450	1400	700	760	
	37	680	460	450	1400	700	780	
V0494-880 (8 POLES)	7.5	Contact EBARA						
	11	Contact EBARA						
	15	Contact EBARA						
V0554-1170 (6 POLES)	37	680	540	390	1480	700	820	
	45	680	540	390	1580	700	850	
	55	680	540	390	1580	700	850	
V0554-880 (8 POLES)	15	Contact EBARA						
	18.5	680	540	390	1480	700	800	
	22	680	540	390	1480	700	820	
	30	680	540	390	1580	700	850	
V0754-885 (8 POLES)	75	880	700	515	1970	900	1500	
	90	1030	700	615	2200	1050	2040	
	110	1030	700	615	2200	1050	2100	
	132	1030	700	615	2200	1050	2170	

**Dimensions are Approximate**

Note:

†1 Includes weight of 33 ft. standard length cables.

†2 Consult EBARA if smaller diameter is required.





**Dimensions**

Project: \_\_\_\_\_ Model: \_\_\_\_\_ Chk'd: \_\_\_\_\_ Date: \_\_\_\_\_

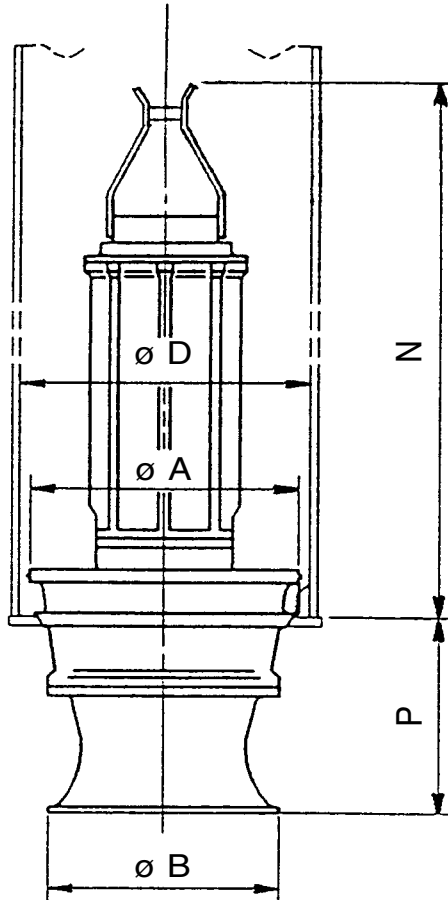
**Apply to Model V0754, V0854, V0974**

**Dimensions: inch**

Model (Pole)	HP	Pump & Motor					Column Pipe Dia. D (†2)	Weight Lbs (†1)
		A (†2)	B	P	N			
V0754-710 (10 POLES)	50	34 <sup>5</sup> / <sub>8</sub>	27 <sup>9</sup> / <sub>16</sub>	20 <sup>1</sup> / <sub>4</sub>	71 <sup>5</sup> / <sub>8</sub>	36	3020	
	60	34 <sup>5</sup> / <sub>8</sub>	27 <sup>9</sup> / <sub>16</sub>	20 <sup>1</sup> / <sub>4</sub>	77 <sup>9</sup> / <sub>16</sub>	36	3219	
	75	34 <sup>5</sup> / <sub>8</sub>	27 <sup>9</sup> / <sub>16</sub>	20 <sup>1</sup> / <sub>4</sub>	77 <sup>9</sup> / <sub>16</sub>	36	3307	
	100	40 <sup>9</sup> / <sub>16</sub>	27 <sup>9</sup> / <sub>16</sub>	24 <sup>3</sup> / <sub>16</sub>	86 <sup>5</sup> / <sub>8</sub>	42	4608	
V0854-710 (10 POLES)	100	40 <sup>3</sup> / <sub>4</sub>	28 <sup>3</sup> / <sub>4</sub>	25 <sup>9</sup> / <sub>16</sub>	86 <sup>1</sup> / <sub>4</sub>	42	4784	
	120	46 <sup>7</sup> / <sub>16</sub>	28 <sup>3</sup> / <sub>4</sub>	25 <sup>9</sup> / <sub>16</sub>	86 <sup>1</sup> / <sub>4</sub>	48	5247	
	145	46 <sup>7</sup> / <sub>16</sub>	28 <sup>3</sup> / <sub>4</sub>	25 <sup>9</sup> / <sub>16</sub>	90 <sup>3</sup> / <sub>16</sub>	48	5556	
V0974-710 (10 POLES)	175	52 <sup>3</sup> / <sub>16</sub>	39 <sup>3</sup> / <sub>8</sub>	28 <sup>15</sup> / <sub>16</sub>	94 <sup>1</sup> / <sub>8</sub>	54	7716	
	200	52 <sup>3</sup> / <sub>16</sub>	39 <sup>3</sup> / <sub>8</sub>	28 <sup>15</sup> / <sub>16</sub>	94 <sup>1</sup> / <sub>8</sub>	54	7937	
	215	52 <sup>3</sup> / <sub>16</sub>	39 <sup>3</sup> / <sub>8</sub>	28 <sup>15</sup> / <sub>16</sub>	94 <sup>1</sup> / <sub>8</sub>	54	7937	
	245	52 <sup>3</sup> / <sub>16</sub>	39 <sup>3</sup> / <sub>8</sub>	28 <sup>15</sup> / <sub>16</sub>	101 <sup>15</sup> / <sub>16</sub>	54	8245	
	265	52 <sup>3</sup> / <sub>16</sub>	39 <sup>3</sup> / <sub>8</sub>	28 <sup>15</sup> / <sub>16</sub>	101 <sup>15</sup> / <sub>16</sub>	54	8422	

**Dimensions: mm**

Model (Pole)	KW	PUMP & MOTOR					Column Pipe Dia. D (†2)	Weight kgf (†1)
		A (†2)	B	P	N			
V0754-710 (10 POLES)	37	880	700	515	1820	900	1370	
	45	880	700	515	1970	900	1460	
	55	880	700	515	1970	900	1500	
	75	1030	700	615	2200	1050	2090	
V0854-710 (10 POLES)	75	1030	730	650	2190	1050	2170	
	90	1180	730	650	2190	1200	2380	
	110	1180	730	650	2290	1200	2520	
V0974-710 (10 POLES)	132	1325	1000	735	2390	1350	3500	
	150	1325	1000	735	2390	1350	3600	
	160	1325	1000	735	2390	1350	3600	
	185	1325	1000	735	2590	1350	3740	
	200	1325	1000	735	2590	1350	3820	

**Dimensions are Approximate**

Note:

†1 Includes weight of 33 ft. standard length cables.

†2 Consult EBARA if smaller diameter is required.



**Dimensions**

Project: \_\_\_\_\_ Model: \_\_\_\_\_ Chk'd: \_\_\_\_\_ Date: \_\_\_\_\_

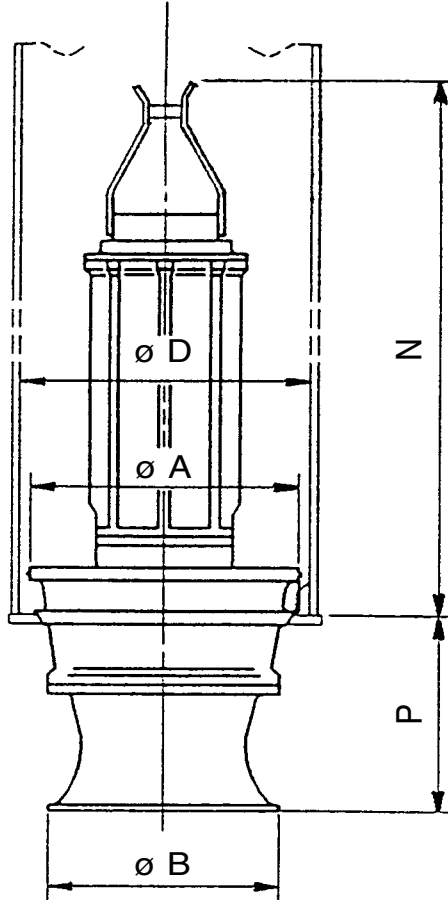
**Apply to Model V1154**

**Dimensions: inch**

Model (Pole)	HP	Pump & Motor					Column Pipe Dia. D	Weight Lbs (†1)
		A	B	P	N			
V1154-593 (12 POLES)	200	52 <sup>3/16</sup>	44 <sup>1/2</sup>	31 <sup>11/16</sup>	101 <sup>15/16</sup>	54	8730	
	215	52 <sup>3/16</sup>	44 <sup>1/2</sup>	31 <sup>11/16</sup>	101 <sup>15/16</sup>	54	8951	
	245	52 <sup>3/16</sup>	44 <sup>1/2</sup>	31 <sup>11/16</sup>	101 <sup>15/16</sup>	54	9149	
	265	58 <sup>7/16</sup>	44 <sup>1/2</sup>	31 <sup>11/16</sup>	101 <sup>15/16</sup>	60	9568	
	295	58 <sup>7/16</sup>	44 <sup>1/2</sup>	31 <sup>11/16</sup>	101 <sup>15/16</sup>	60	9568	
	335	Contact EBARA						
	375	Contact EBARA						
422	58 <sup>1/16</sup>	44 <sup>1/2</sup>	31 <sup>11/16</sup>	118	60	14300		

**Dimensions: mm**

Model (Pole)	KW	Pump & Motor					Column Pipe Dia. D	Weight kgf (†1)
		A	B	P	N			
V1154-593 (12 POLES)	150	1325	1130	805	2590	1350	3960	
	160	1325	1130	805	2590	1350	4060	
	185	1325	1130	805	2590	1350	4150	
	200	1475	1130	805	2590	1500	4340	
	220	1475	1130	805	2590	1500	4340	
	250	Contact EBARA						
	280	Contact EBARA						
315	1475	1130	805	3000	1500	6500		

**Dimensions are Approximate**

Note:

†1 Includes weight of 33 ft. standard length cables.

**Sectional View**

Project: \_\_\_\_\_

Model: \_\_\_\_\_

Chk'd: \_\_\_\_\_

Date: \_\_\_\_\_

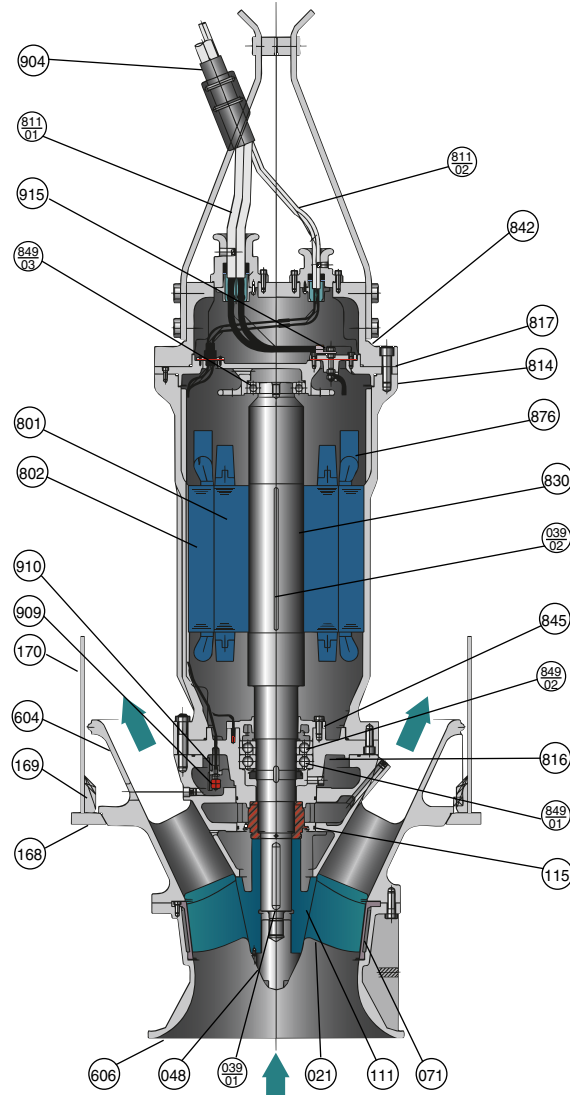

No.	Qty	Part Name	Material	ATM/AISI Code	No.	Qty	Part Name	Material	ATM/AISI Code
915	1	Terminal Board			811-01	1	Power Cable		
910	1	Leakage Detector Support	Cast Iron	ASTM A48 CL. 30	802	1	Stator	Copper	
909	1	Leakage Detector			801	1	Rotor	Aluminum	
904	1	Lifting Hanger	Steel	ASTM A283 GR.D	606	1	Suction Bell	Cast Iron	ASTM A48 CL. 35
876	1	Thermal Protector			604	1	Discharge Bowl	Cast Iron	ASTM A48 CL. 35
849-03	1	Ball Bearing	Steel		170	1	Column Pipe	Steel	ASTM A283 GR. D
849-02	1	Ball Bearing	Steel		169	1	Rotation Stopper	Steel	ASTM A283 GR. D
849-01	1	Ball Bearing	Steel		168	1	Sole Plate	Steel	ASTM A283 GR. D
845	1	Bearing Cover	Cast Iron	ASTM A48 CL. 30	115	1	O Ring	NBR	
842	1	Motor Cover	Cast Iron	ASTM A48 CL. 35	111	1	Mechanical Seal	See Detail	
830	1	Shaft	Stainless	AISI 403	071	1	Casing Liner	Stainless	ASTM A743-CF8
817	1	Opposite Side Bracket	Cast Iron	ASTM A48 CL. 35	048	1	Impeller Nut	Stainless	AISI 403
816	1	Power Side Bracket	Cast Iron	ASTM A48 CL. 35	039-02	1	Key	Steel	AISI 1050
814	1	Motor Frame	Cast Iron	ASTM A48 CL. 35	039-01	1	Key	Stainless	AISI 420
811-02	1	Control Cable			021	1	Impeller	Ductile Iron	ASTM A536-60-40

**Optional Materials**

021	1	Impeller	Stainless	ASTM A743 CF8
021	1	Impeller	Bronze	ASTM B584 C90300



**Accessories**

Project: \_\_\_\_\_ Model: \_\_\_\_\_ Chk'd: \_\_\_\_\_ Date: \_\_\_\_\_

**Sole Plate – (Standard Supply)**

Ebara DSZ3 pump is installed on the sole plate with a rotation stopper.

The sole plate is designed and manufactured by Ebara and is to be welded to the column pipe in accordance with the welding procedure prepared by Ebara.

Material: Rolled Steel, ASTM A283 Gr.D

Note:

Concentricity of D to B or C shall be as follows:

Max. concentricity

2.0mm for D=450–800mm

3.0mm for D=900–1350mm

4.0mm for D=1400–2000mm

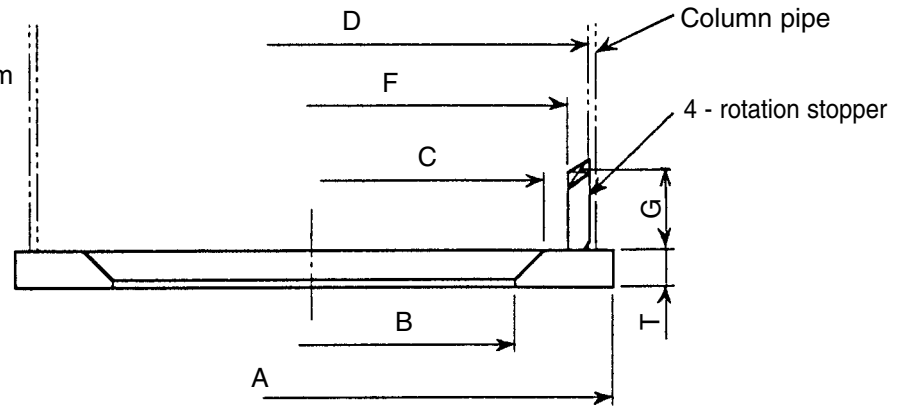

**UNIT : INCH (mm)**

Pipe Dia.	Min. Inside Dia. D	A	B	C	F	G	T	Lbs (kgf)
18 (450)	17 <sup>5</sup> / <sub>16</sub> (440)	20 <sup>1</sup> / <sub>16</sub> (510)	14 <sup>5</sup> / <sub>16</sub> (364)	15 <sup>3</sup> / <sub>16</sub> (385)	15 <sup>15</sup> / <sub>16</sub> (405)	2 <sup>3</sup> / <sub>16</sub> (55)	7/8 (22)	37 (17)
20 (500)	19 <sup>5</sup> / <sub>16</sub> (490)	22 <sup>1</sup> / <sub>16</sub> (560)	16 <sup>5</sup> / <sub>16</sub> (414)	17 <sup>7</sup> / <sub>8</sub> (435)	17 <sup>15</sup> / <sub>16</sub> (455)	2 <sup>3</sup> / <sub>16</sub> (55)	7/8 (22)	42 (19)
24 (600)	23 <sup>1</sup> / <sub>4</sub> (590)	26 (660)	20 <sup>1</sup> / <sub>4</sub> (514)	21 <sup>1</sup> / <sub>16</sub> (535)	21 <sup>7</sup> / <sub>8</sub> (555)	2 <sup>3</sup> / <sub>8</sub> (60)	7/8 (22)	51 (23)
28 (700)	27 <sup>3</sup> / <sub>16</sub> (690)	29 <sup>15</sup> / <sub>16</sub> (760)	23 <sup>1</sup> / <sub>2</sub> (597)	24 <sup>5</sup> / <sub>8</sub> (625)	25 <sup>7</sup> / <sub>16</sub> (646)	2 <sup>3</sup> / <sub>8</sub> (60)	1 <sup>1</sup> / <sub>8</sub> (28)	84 (38)
30 (750)	29 <sup>1</sup> / <sub>8</sub> (740)	31 <sup>7</sup> / <sub>8</sub> (810)	25 <sup>1</sup> / <sub>2</sub> (647)	26 <sup>9</sup> / <sub>16</sub> (675)	27 <sup>1</sup> / <sub>2</sub> (698)	2 <sup>9</sup> / <sub>16</sub> (65)	1 <sup>1</sup> / <sub>8</sub> (28)	90 (41)
32 (800)	31 <sup>1</sup> / <sub>8</sub> (790)	33 <sup>7</sup> / <sub>8</sub> (860)	27 <sup>1</sup> / <sub>16</sub> (687)	28 <sup>1</sup> / <sub>8</sub> (715)	29 <sup>1</sup> / <sub>16</sub> (738)	2 <sup>9</sup> / <sub>16</sub> (65)	1 <sup>1</sup> / <sub>8</sub> (28)	101 (46)
36 (900)	35 <sup>1</sup> / <sub>16</sub> (890)	37 <sup>13</sup> / <sub>16</sub> (960)	31 (787)	32 <sup>1</sup> / <sub>16</sub> (815)	33 <sup>3</sup> / <sub>16</sub> (840)	2 <sup>3</sup> / <sub>4</sub> (70)	1 <sup>1</sup> / <sub>8</sub> (28)	115 (52)
40 (1000)	39 (990)	42 <sup>1</sup> / <sub>8</sub> (1070)	34 <sup>9</sup> / <sub>16</sub> (878)	35 <sup>13</sup> / <sub>16</sub> (910)	36 <sup>13</sup> / <sub>16</sub> (935)	2 <sup>3</sup> / <sub>4</sub> (70)	1 <sup>1</sup> / <sub>4</sub> (32)	163 (74)
42 (1050)	40 <sup>15</sup> / <sub>16</sub> (1040)	44 <sup>1</sup> / <sub>8</sub> (1120)	36 <sup>9</sup> / <sub>16</sub> (928)	37 <sup>13</sup> / <sub>16</sub> (960)	38 <sup>3</sup> / <sub>4</sub> (985)	2 <sup>3</sup> / <sub>4</sub> (70)	1 <sup>1</sup> / <sub>4</sub> (32)	172 (78)
48 (1200)	46 <sup>7</sup> / <sub>8</sub> (1190)	50 (1270)	42 <sup>1</sup> / <sub>16</sub> (1068)	43 <sup>5</sup> / <sub>16</sub> (1100)	44 <sup>1</sup> / <sub>2</sub> (1130)	3 <sup>1</sup> / <sub>8</sub> (80)	1 <sup>1</sup> / <sub>4</sub> (32)	207 (94)
54 (1350)	52 <sup>3</sup> / <sub>4</sub> (1340)	56 <sup>5</sup> / <sub>16</sub> (1430)	47 <sup>7</sup> / <sub>8</sub> (1203)	48 <sup>5</sup> / <sub>8</sub> (1235)	50 <sup>3</sup> / <sub>16</sub> (1275)	3 <sup>1</sup> / <sub>8</sub> (80)	1 <sup>1</sup> / <sub>4</sub> (32)	262 (119)
56 (1400)	54 <sup>3</sup> / <sub>4</sub> (1390)	58 <sup>1</sup> / <sub>4</sub> (1480)	49 <sup>5</sup> / <sub>16</sub> (1253)	50 <sup>9</sup> / <sub>16</sub> (1285)	52 <sup>3</sup> / <sub>16</sub> (1325)	3 <sup>1</sup> / <sub>8</sub> (80)	1 <sup>1</sup> / <sub>4</sub> (32)	271 (123)
60 (1500)	58 <sup>11</sup> / <sub>16</sub> (1490)	62 <sup>3</sup> / <sub>16</sub> (1580)	53 <sup>1</sup> / <sub>4</sub> (1353)	54 <sup>1</sup> / <sub>2</sub> (1385)	56 <sup>1</sup> / <sub>8</sub> (1425)	3 <sup>1</sup> / <sub>8</sub> (80)	1 <sup>1</sup> / <sub>4</sub> (32)	291 (132)
64 (1600)	62 <sup>5</sup> / <sub>8</sub> (1590)	65 <sup>3</sup> / <sub>4</sub> (1670)	57 <sup>1</sup> / <sub>16</sub> (1449)	58 <sup>7</sup> / <sub>16</sub> (1485)	60 <sup>1</sup> / <sub>16</sub> (1525)	3 <sup>1</sup> / <sub>8</sub> (80)	1 <sup>7</sup> / <sub>16</sub> (36)	373 (169)
72 (1800)	70 <sup>1</sup> / <sub>2</sub> (1790)	74 <sup>7</sup> / <sub>16</sub> (1890)	64 <sup>15</sup> / <sub>16</sub> (1649)	66 <sup>5</sup> / <sub>16</sub> (1685)	67 <sup>15</sup> / <sub>16</sub> (1725)	3 <sup>1</sup> / <sub>8</sub> (80)	1 <sup>7</sup> / <sub>16</sub> (36)	419 (190)
80 (2000)	78 <sup>3</sup> / <sub>8</sub> (1990)	82 <sup>5</sup> / <sub>8</sub> (2100)	72 <sup>5</sup> / <sub>8</sub> (1844)	74 (1880)	75 <sup>9</sup> / <sub>16</sub> (1920)	3 <sup>1</sup> / <sub>8</sub> (80)	1 <sup>7</sup> / <sub>16</sub> (36)	496 (225)

**Accessories**

Project: \_\_\_\_\_ Model: \_\_\_\_\_ Chk'd: \_\_\_\_\_ Date: \_\_\_\_\_

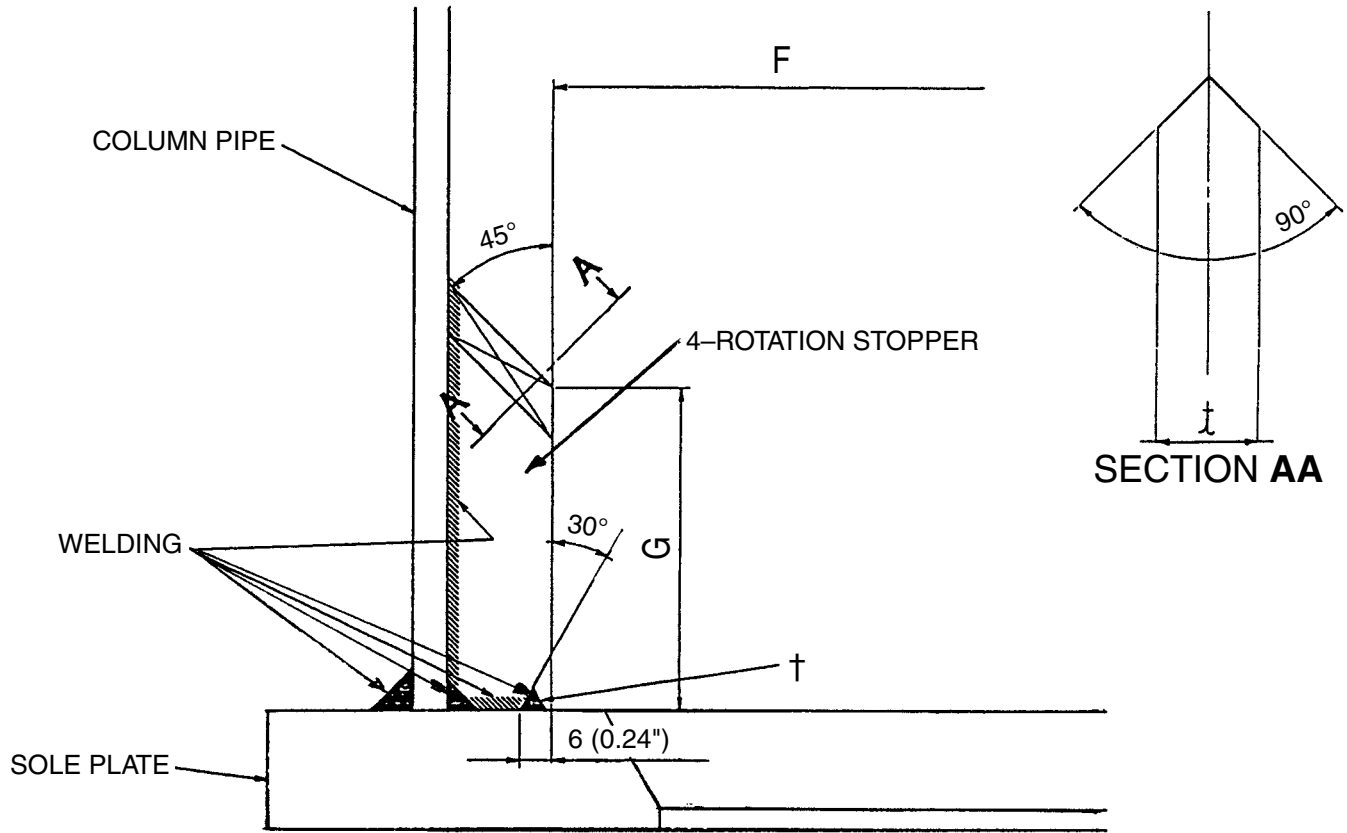
**Sole Plate Welding Procedures**



†: The welding bead is not to be projected from the inner surface of the rotation stopper.