

Contents

Model

50CSHU6.4
50CSHU6.75
50CSHU61.5
50CSU62.2
50CSHU62.2
50CSU63.7
50CSHU63.7
80CSU62.2
80CSHU62.2
80CSU63.7
80CSHU63.7
100CSU65.5
100CSU67.5

Section	Page
Specifications	1002
Selection Chart	1003
Performance Curves	1006
Dimensions	1011
Sectional View	1014
QDC Information	1400
Motor Data	1500
motor electrical specifications	
cable data	
wiring diagrams	
motor electrical data	

Model CSU

EBARA PRO Cast Sump Pumps

Model Designation

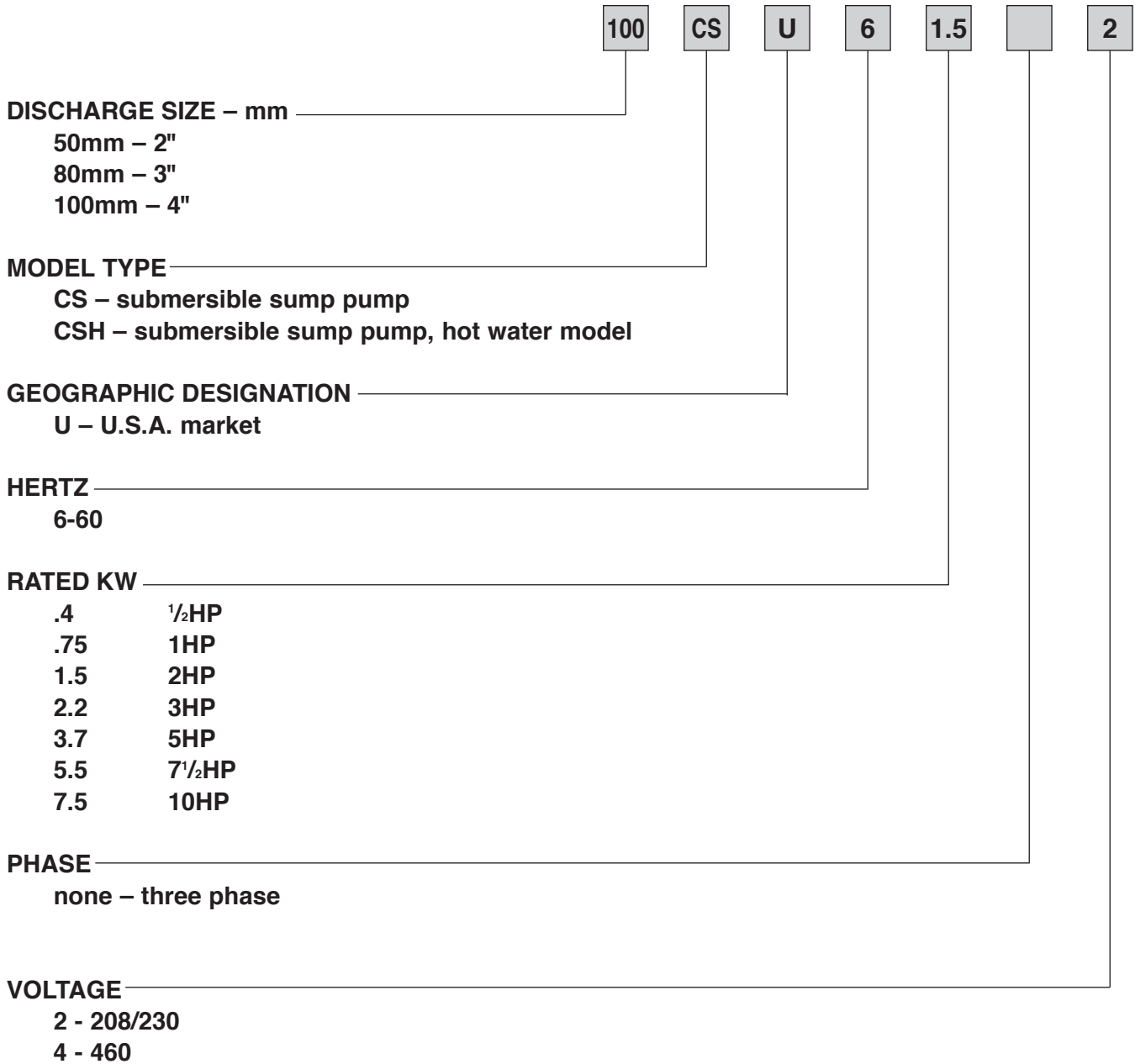

Specifications

	Standard	Optional
Size	2, 3, 4 inch	
Range of HP	3 HP to 10 HP	
Range of Performance	Capacity 8 to 390 GPM Head 10 to 126 feet	
Limitation Maximum Water Temperature	122°F (50°C)	
Synchronous Speed	3600 RPM	
Materials Casing Impeller Shaft Motor Frame Fastener	Cast Iron Ductile Iron 403 Stainless Steel Cast Iron 304 Stainless Steel	
Mechanical Seal Material – Upper Side Material – Lower Side Impeller Type Bearing Motor Three Phase Service Factor Motor Protection Submersible Cable Accessories	Double Mechanical Seal Carbon/Ceramic Silicon Carbide/Silicon Carbide Semi-open Prelubricated Ball Bearing Air-filled, Insulation Class F 208/230/460V 1.15 Built-in Auto Cut - overload, out of phase, single phasing protection 33 ft. standard cable length Cast iron discharge elbow (3 to 5 HP)	66 ft. QDC System

Selection Chart

Three Phase

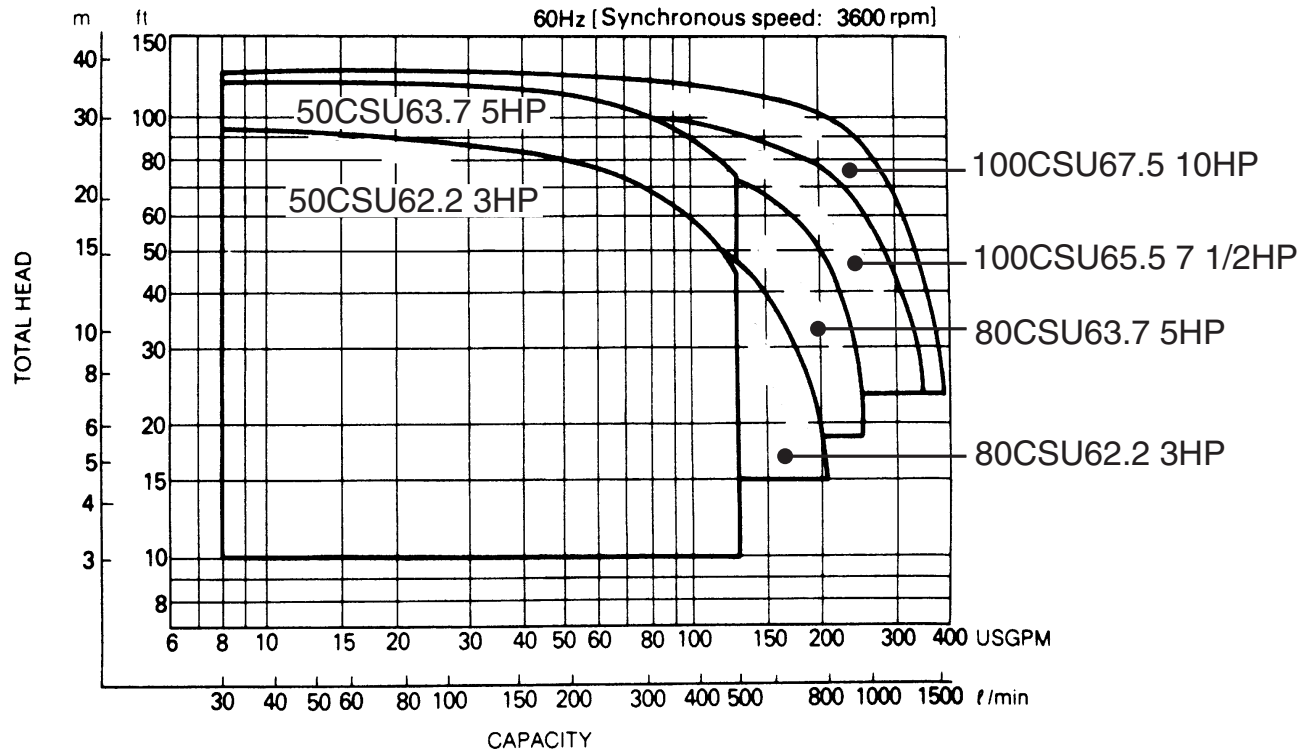

Specifications

	Standard	Optional
Size	2, 3 inch	
Range of HP Range of Performance	1/2 HP to 5 HP Capacity 8 to 250 GPM Head 8 to 126 feet	
Limitation Maximum Water Temperature	158°F (70°C) 1/2 HP, 1 HP 176°F (80°C) 2 HP to 5 HP 200°F (93°C) Operation is limited to 10 minutes	
Synchronous Speed	3600 RPM	
Materials Casing Impeller Shaft Motor Frame Fastener	Cast Iron Cast Iron (1/2 to 2 HP), Ductile Iron (3, 5 HP) 403 Stainless Steel Cast Iron 304 Stainless Steel	
Mechanical Seal Material – Upper Side Material – Lower Side Impeller Type Bearing Motor Three Phase Service Factor Motor Protection Submersible Cable Accessories	Double Mechanical Seal Silicon Carbide/Silicon Carbide Silicon Carbide/Silicon Carbide Semi-open Prelubricated Ball Bearing Air-filled, Insulation Class H (1/2, 1HP) Class F (2, 3, 5 HP) 208/230V, 460V - Single voltage 1.15 Built-in Overload Protection 20 ft. up to 2 HP 33 ft. - 3, 5 HP Cast Iron companion flange with NPT thread (1/2 to 2HP) Cast iron discharge elbow (3 to 5 HP)	66 ft. QDC System

Selection Chart

Three Phase

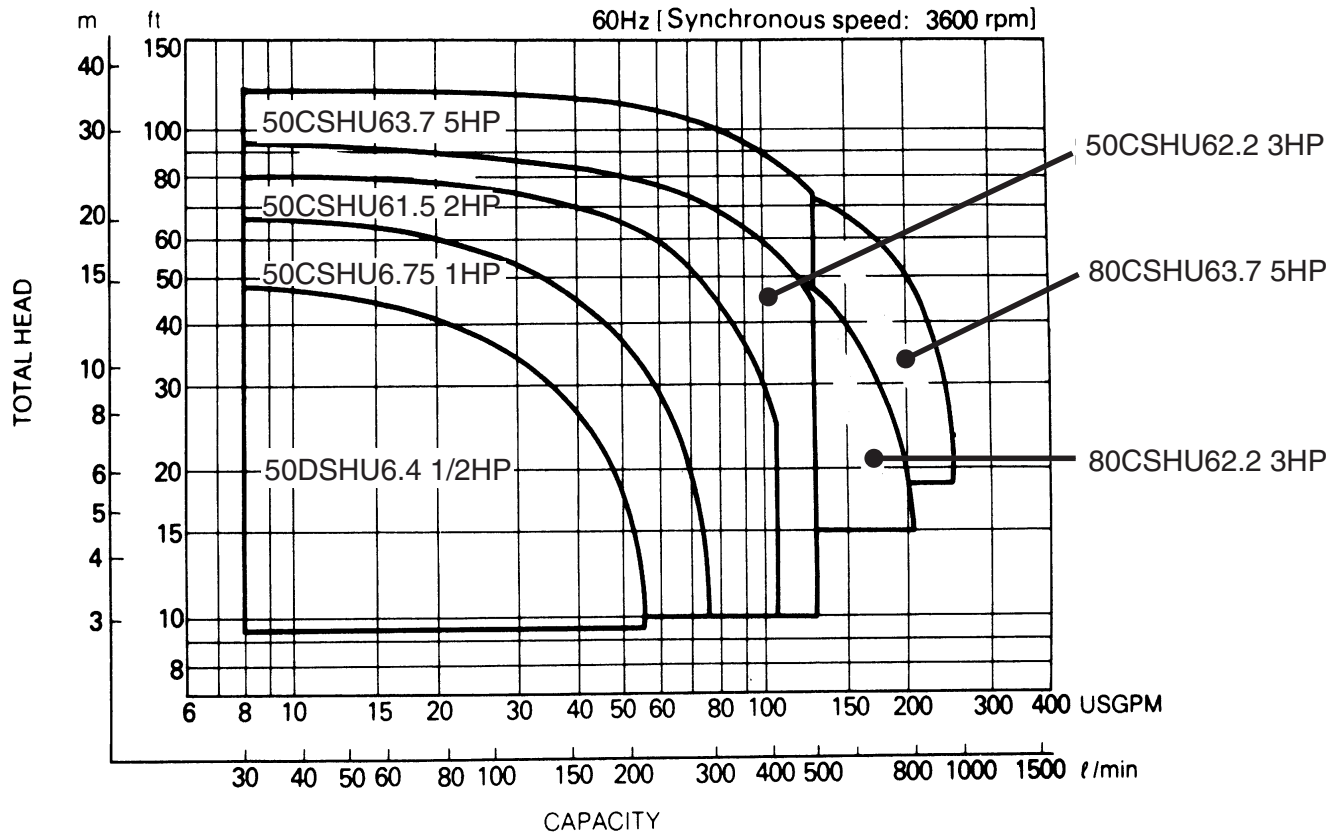

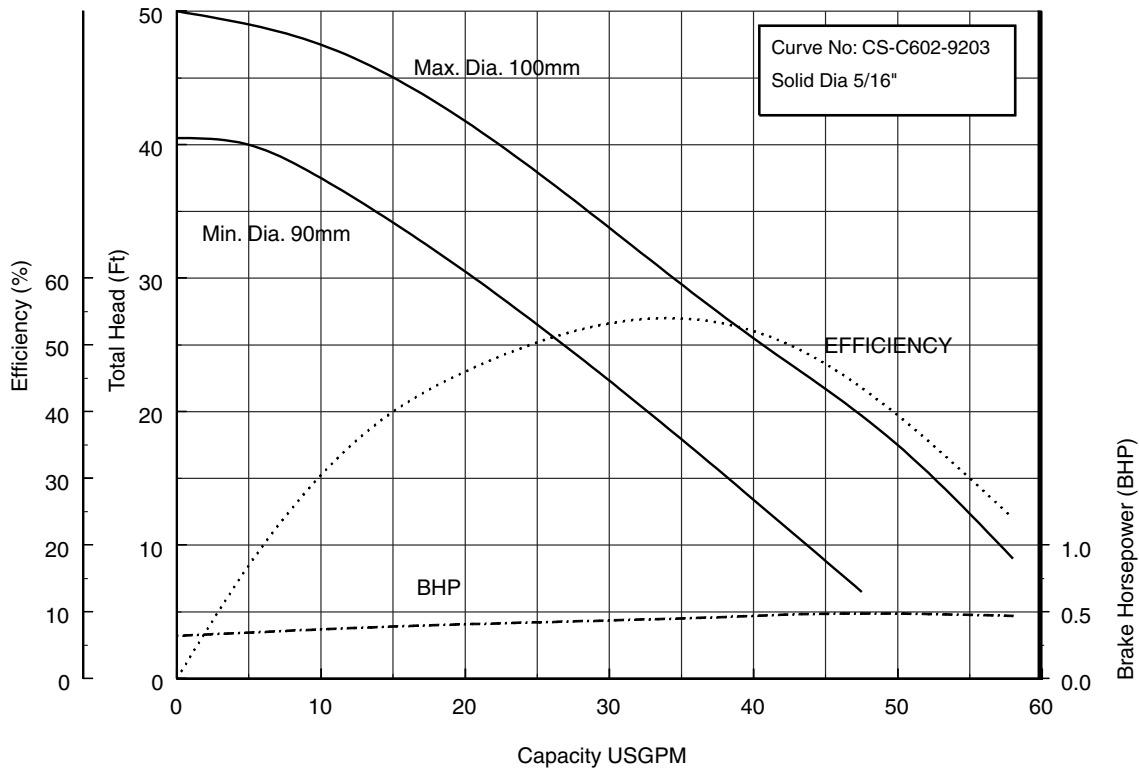
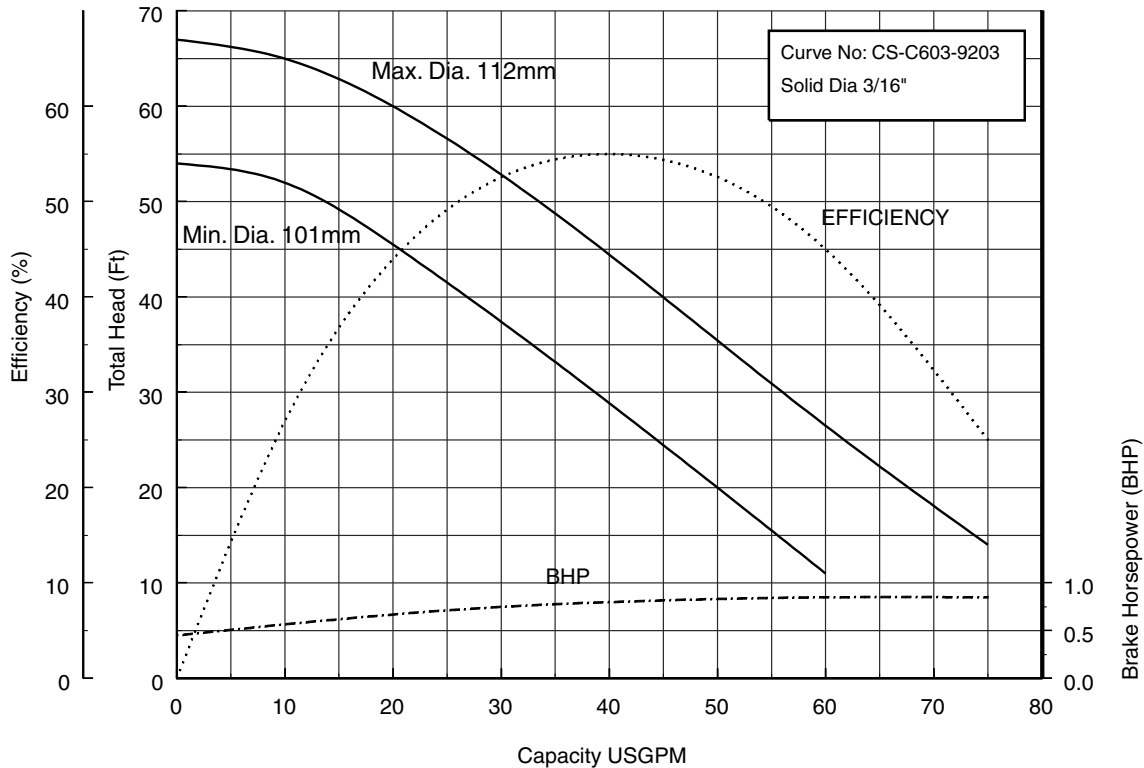
50CSH6.4 (1/2HP)
Synchronous Speed: 3600 RPM
2 inch Discharge

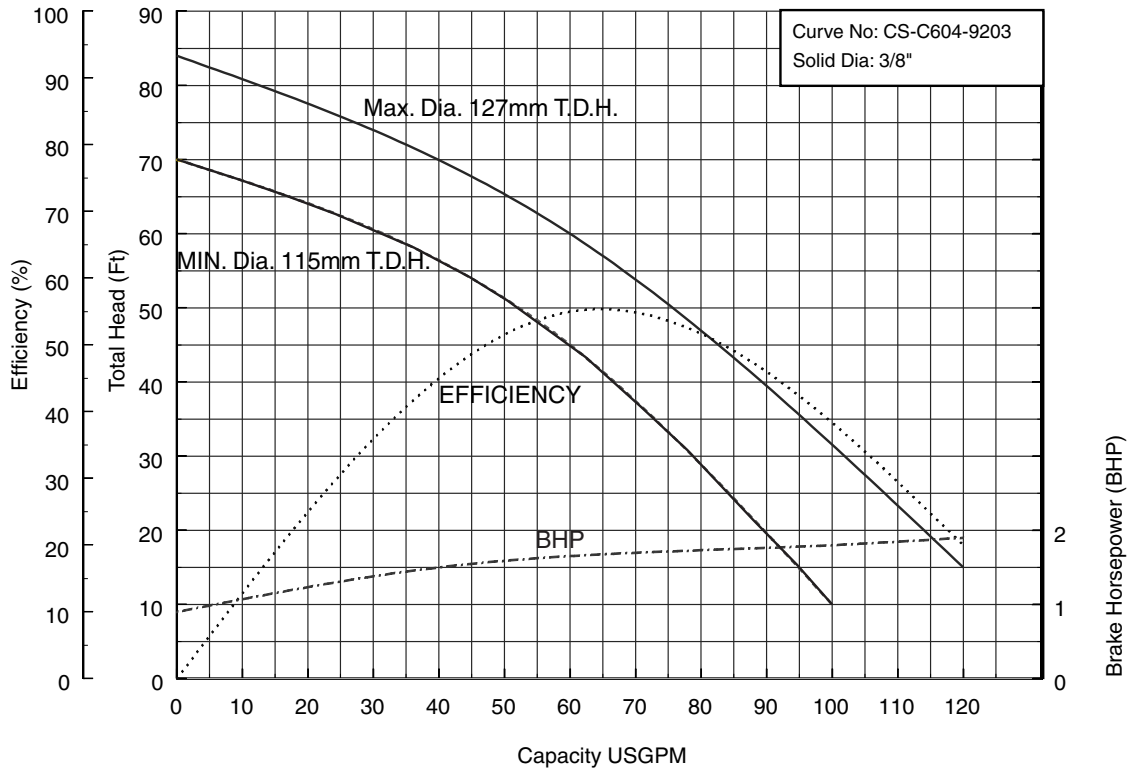
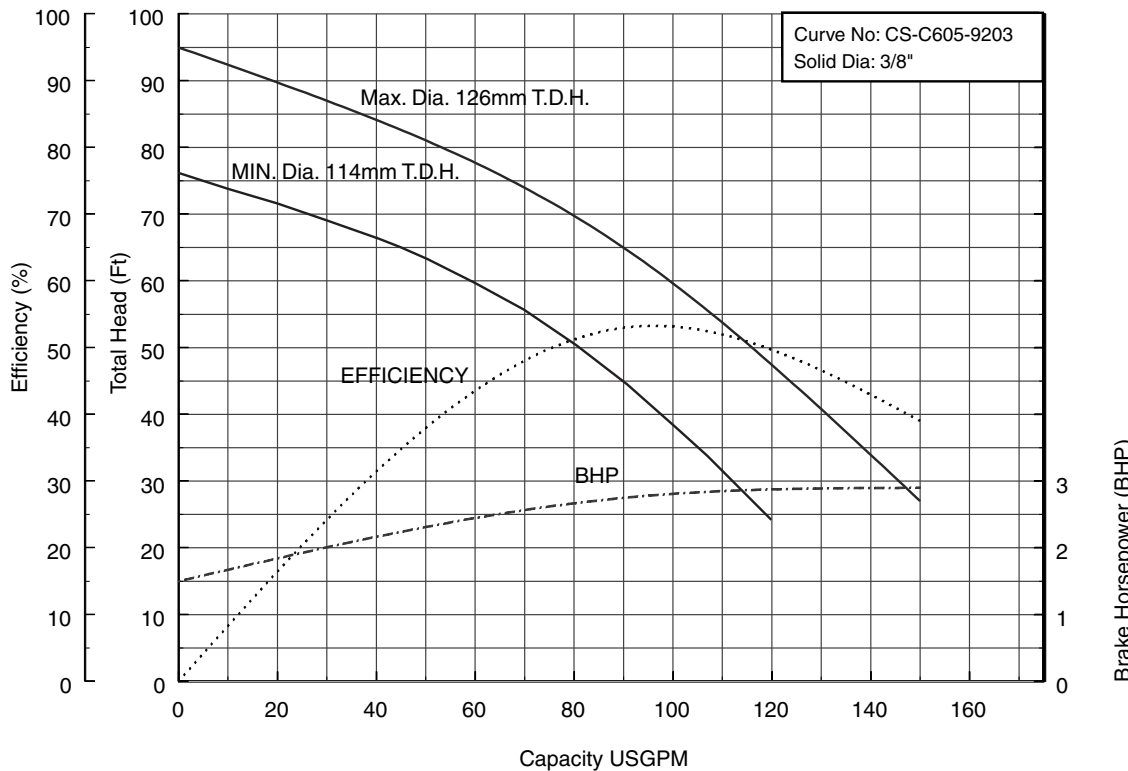
50CSH6.75 (1HP)
Synchronous Speed: 3600 RPM
2 inch Discharge

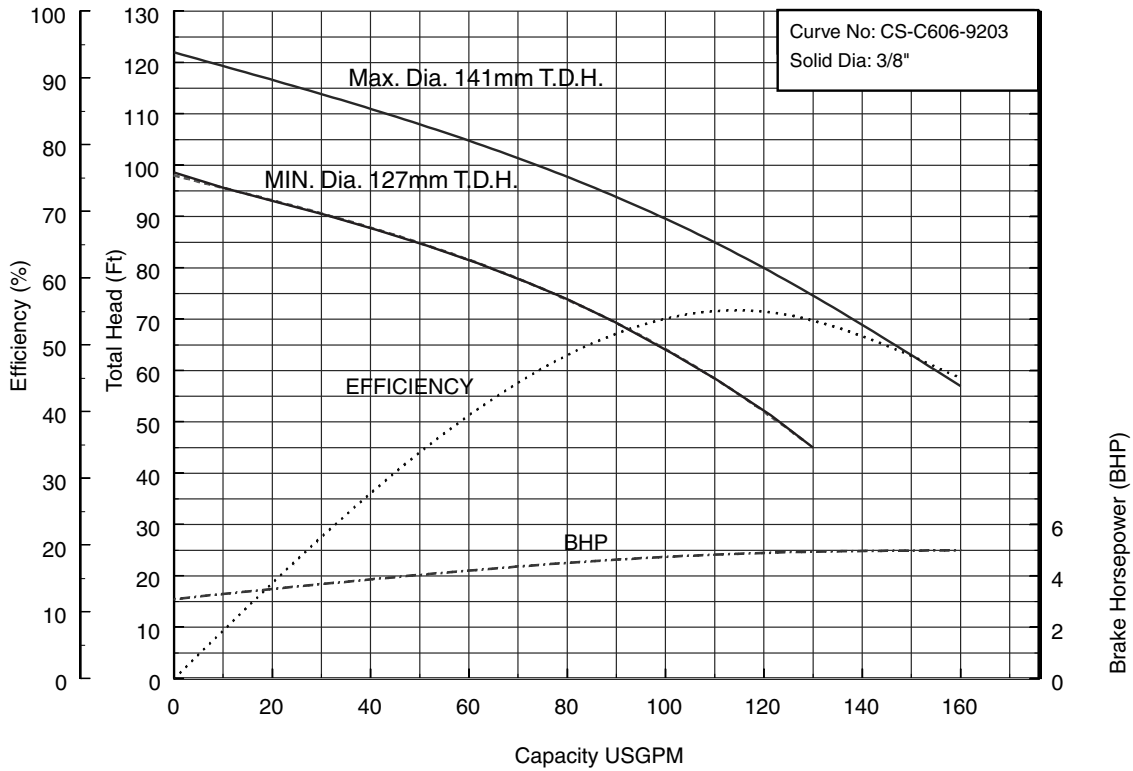
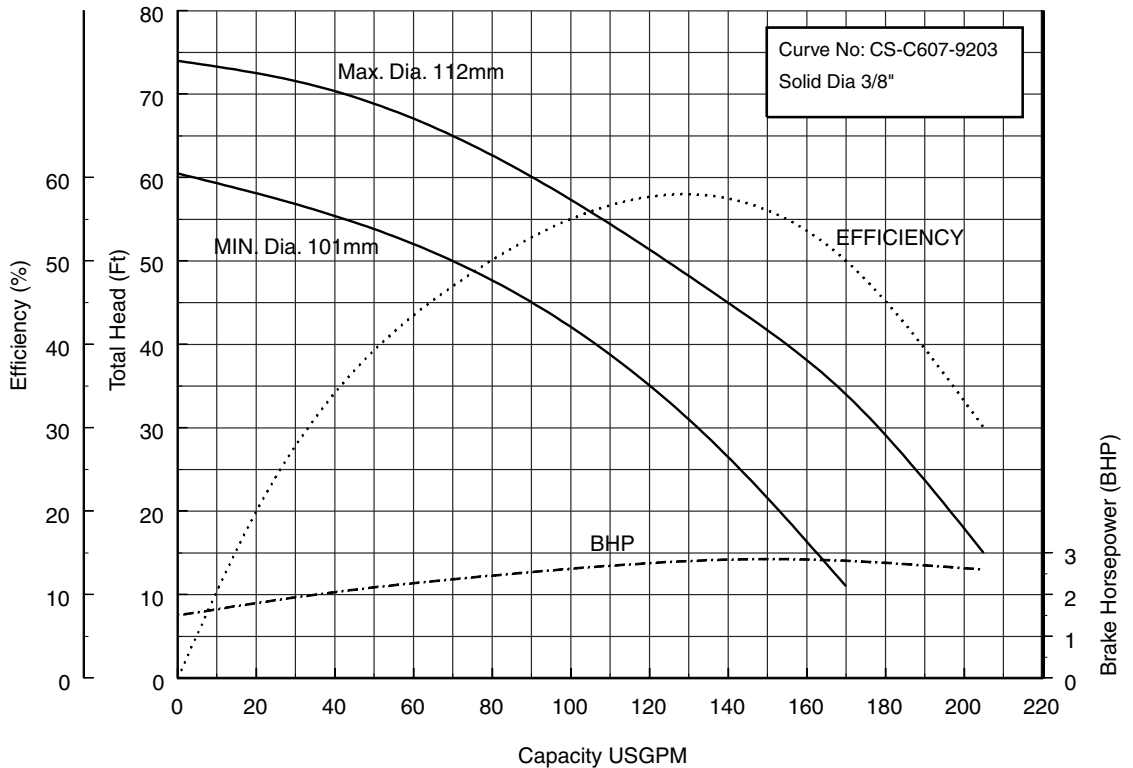
50CSH61.5 (2HP)
Synchronous Speed: 3600 RPM
2 inch Discharge

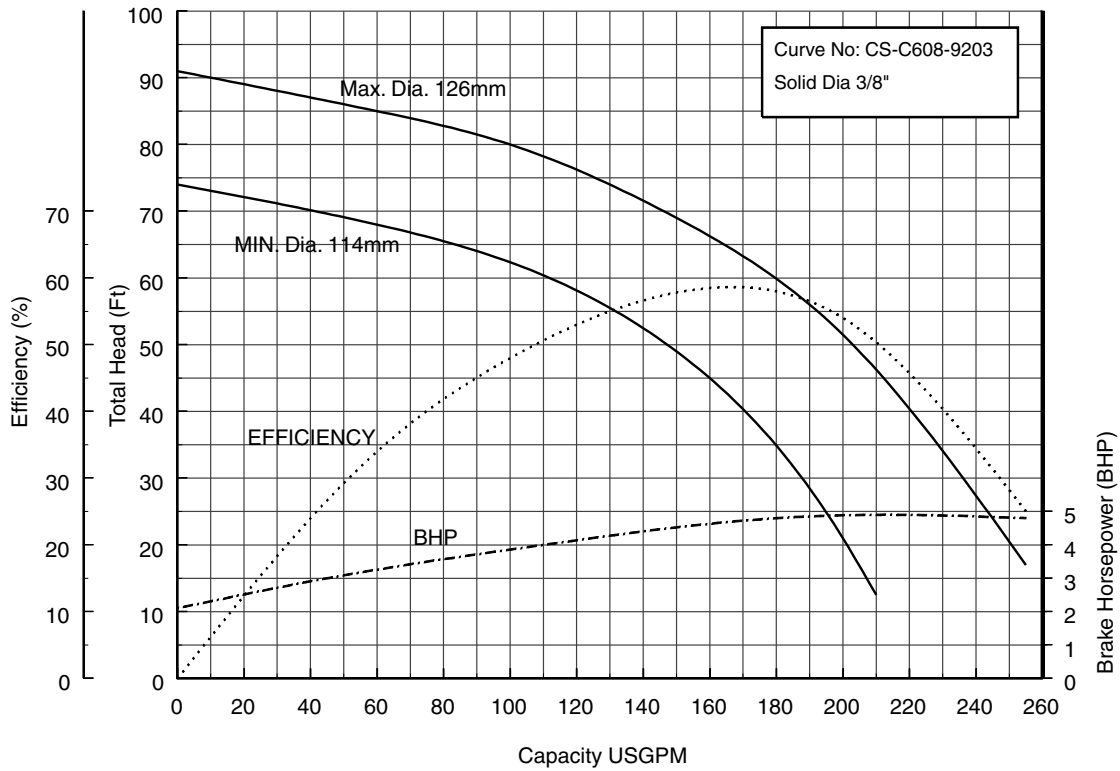
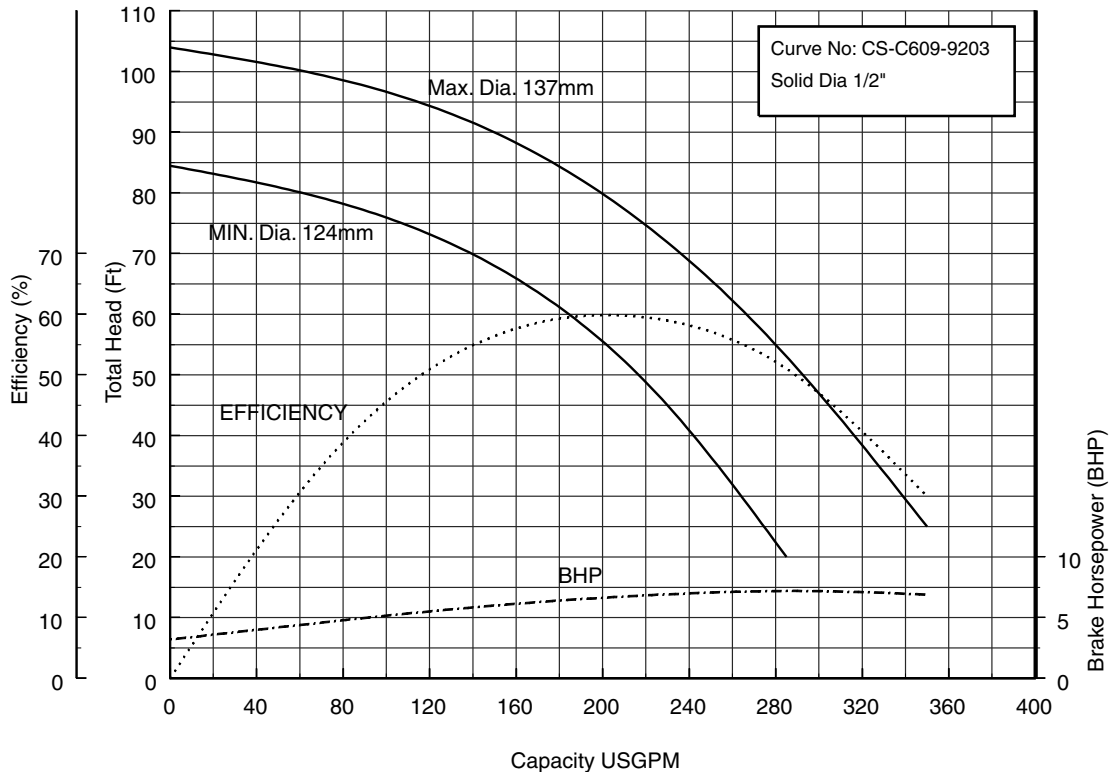
50CS62.2 50CSH62.2 (3HP) Synchronous Speed: 3600 RPM
2 inch Discharge

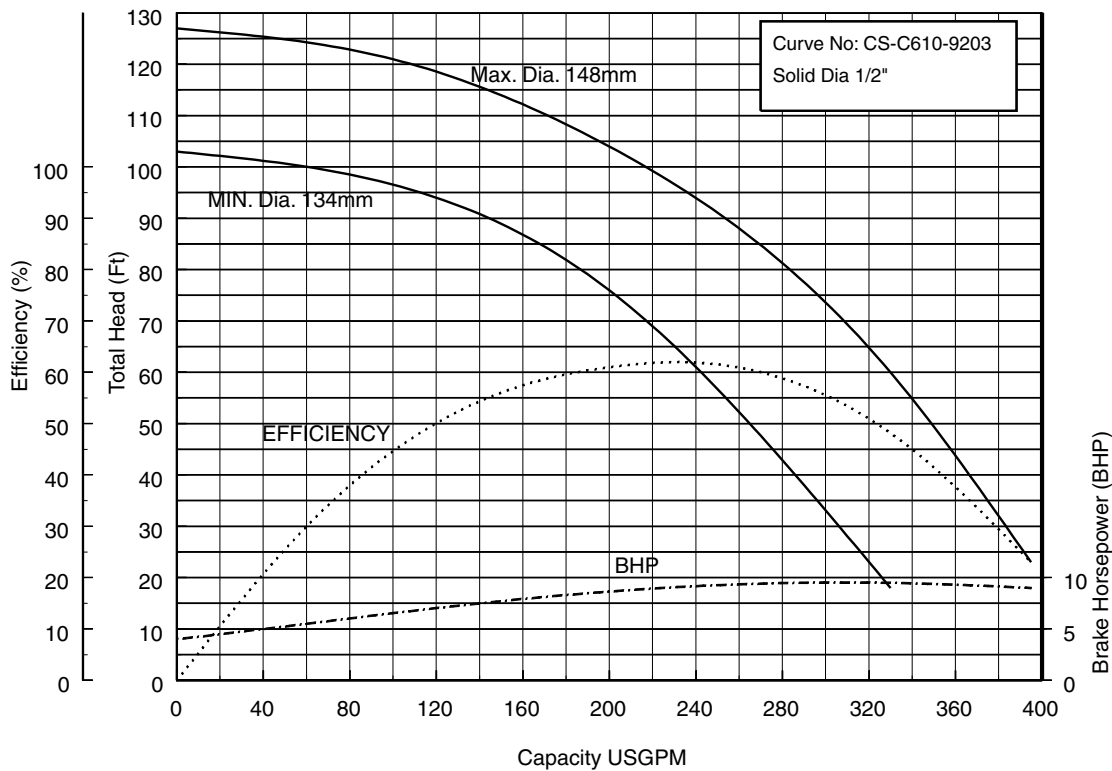
50CS63.7 50CSH63.7 (5HP) Synchronous Speed: 3600 RPM
2 inch Discharge

80CS62.2 80CSH62.2 (3HP) Synchronous Speed: 3600 RPM
3 inch Discharge

80CS63.7 80CSH63.7 (5 HP) Synchronous Speed: 3600 RPM
3 inch Discharge

100CS65.5 (7½ HP)
Synchronous Speed: 3600 RPM
4 inch Discharge

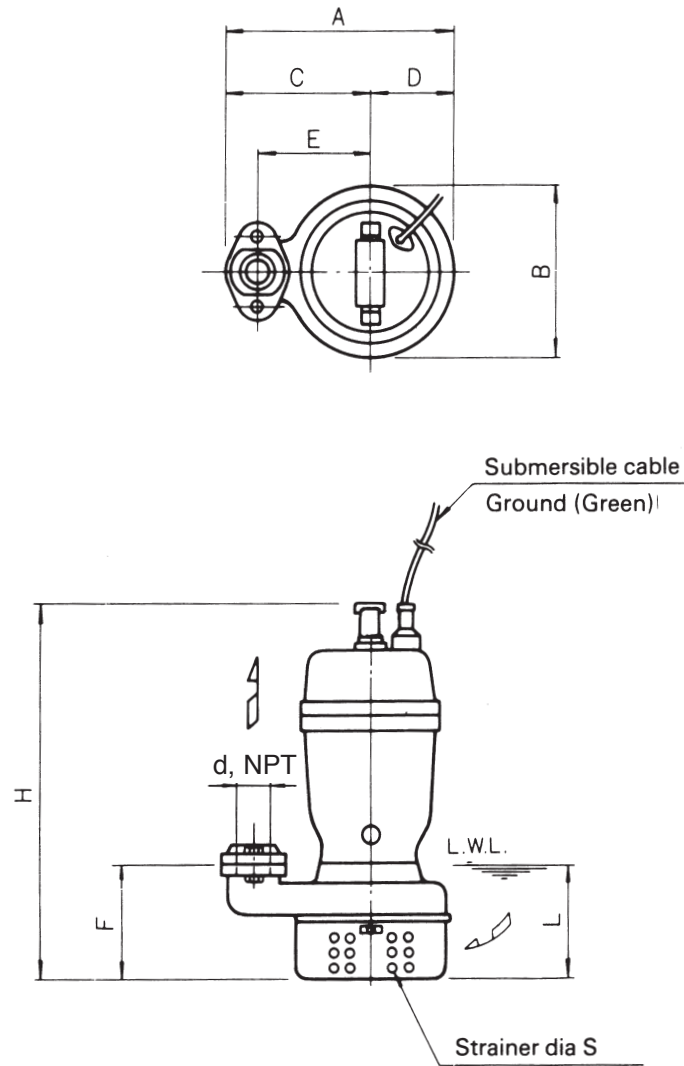

Dimensions

Hot Water Pumps
50CSHU, 1/2 to 2HP

Dimensions: inch

PHASE	SIZE _d	MODEL	OUTPUT		PUMP & MOTOR										WEIGHT Lb
			kW	HP	A	B	C	D	E	F	H	L	S		
THREE	2	50CSHU6.4	0.4	1/2	10 ¹ / ₄	7 ³ / ₁₆	6 ⁵ / ₈	3 ³ / ₈	5 ¹ / ₈	3 ⁷ / ₈	15 ⁹ / ₁₆	4 ³ / ₁₆	5 ¹ / ₁₆	35	
		50CSHU6.75	0.75	1	10 ¹ / ₄	7 ⁵ / ₁₆	6 ⁵ / ₈	3 ⁵ / ₈	5 ¹ / ₈	3 ⁷ / ₈	15 ⁹ / ₁₆	4 ⁵ / ₁₆	5 ¹ / ₁₆	37	
		50CSHU61.5	1.5	2	10 ¹ / ₂	7 ¹ / ₈	6 ⁵ / ₈	3 ⁷ / ₈	5 ¹ / ₈	4 ¹ / ₂	17 ¹¹ / ₁₆	4 ³ / ₄	3 ³ / ₈	57	

Dimensions: mm

PHASE	SIZE _d	MODEL	OUTPUT		PUMP & MOTOR										WEIGHT kg
			kW	HP	A	B	C	D	E	F	H	L	S		
THREE	50	50CSHU6.4	0.4	1/2	260	186	168	92	130	99	396	110	8	16	
		50CSHU6.75	0.75	1	260	186	168	92	130	99	396	110	8	17	
		50CSHU61.5	1.5	2	266	200	168	98	130	115	450	120	10	26	

Model CShU
EBARA PRO Cast Sump Pumps
Dimensions

Hot Water Pumps
 50CSHU, 3 to 5 HP
 80CSHU, 3 to 5 HP

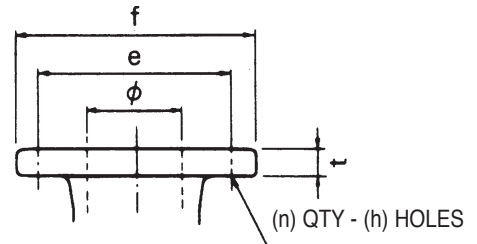
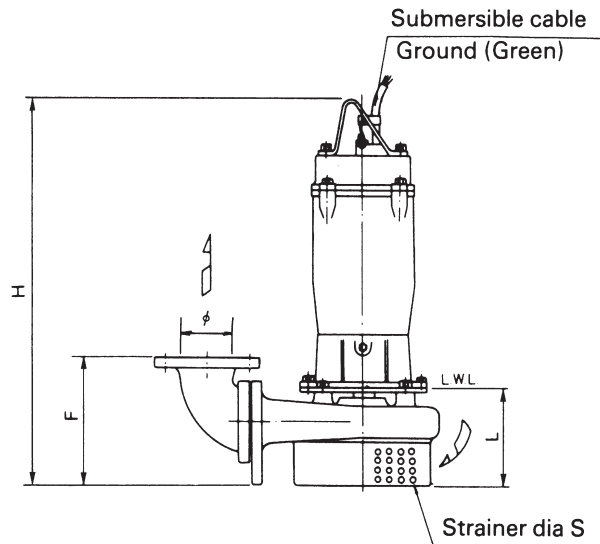
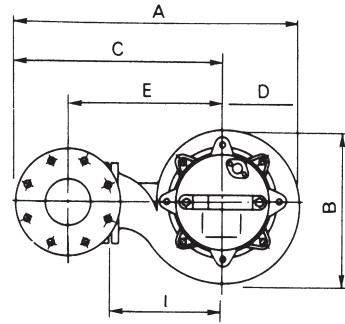
Flange (ANSI 125 PSI F.F)

inch					
ϕ	e	f	t	n	h
2	4 ³ / ₄	6	5 ⁵ / ₈	4	3 ³ / ₄
3	6	7 ¹ / ₂	3 ³ / ₄	4	3 ³ / ₄

mm					
ϕ	e	f	t	n	h
50	121	152	16	4	19
80	152	191	19	4	19

Dimensions: inch

PHASE	SIZE ϕ	MODEL	OUTPUT		PUMP & MOTOR										WEIGHT Lb
			kW	HP	A	B	C	D	E	F	H	I	L	S	
THREE	2	50CSHU62.2	2.2	3	17 ¹ / ₁₆	9 ⁵ / ₈	12 ⁵ / ₁₆	4 ³ / ₄	9 ¹ / ₄	7 ¹³ / ₁₆	24 ¹⁵ / ₁₆	7 ¹ / ₁₆	6 ⁵ / ₁₆	3 ³ / ₈	119
		50CSHU63.7	3.7	5	17 ¹ / ₁₆	9 ⁵ / ₈	12 ⁵ / ₁₆	4 ³ / ₄	9 ¹ / ₄	7 ¹³ / ₁₆	26 ¹ / ₄	7 ¹ / ₁₆	6 ⁵ / ₁₆	3 ³ / ₈	134
	3	80CSHU62.2	2.2	3	19 ¹³ / ₁₆	10 ⁹ / ₁₆	14 ¹ / ₂	5 ⁵ / ₁₆	10 ¹³ / ₁₆	8 ⁷ / ₁₆	25 ⁹ / ₁₆	7 ⁷ / ₈	6 ⁵ / ₁₆	3 ³ / ₈	128
		80CSHU63.7	3.7	5	19 ¹³ / ₁₆	10 ⁹ / ₁₆	14 ¹ / ₂	5 ⁵ / ₁₆	10 ¹³ / ₁₆	8 ⁷ / ₁₆	26 ¹ / ₂	7 ⁷ / ₈	6 ⁵ / ₁₆	3 ³ / ₈	141

Dimensions: mm

PHASE	SIZE ϕ	MODEL	OUTPUT		PUMP & MOTOR										WEIGHT kg
			kW	HP	A	B	C	D	E	F	H	I	L	S	
THREE	50	50CSHU62.2	2.2	3	433	245	313	120	235	198	634	180	160	10	54
		50CSHU63.7	3.7	5	433	245	313	120	235	198	667	180	160	10	61
	80	80CSHU62.2	2.2	3	503	268	368	135	275	215	640	200	160	10	58
		80CSHU63.7	3.7	5	503	268	368	135	275	215	673	200	160	10	64



Model CSU
EBARA PRO Cast Sump Pumps
Dimensions

50CSU, 3 to 5 HP
 80CSHU, 3 to 5 HP
 100CSU, 7½ to 10 HP

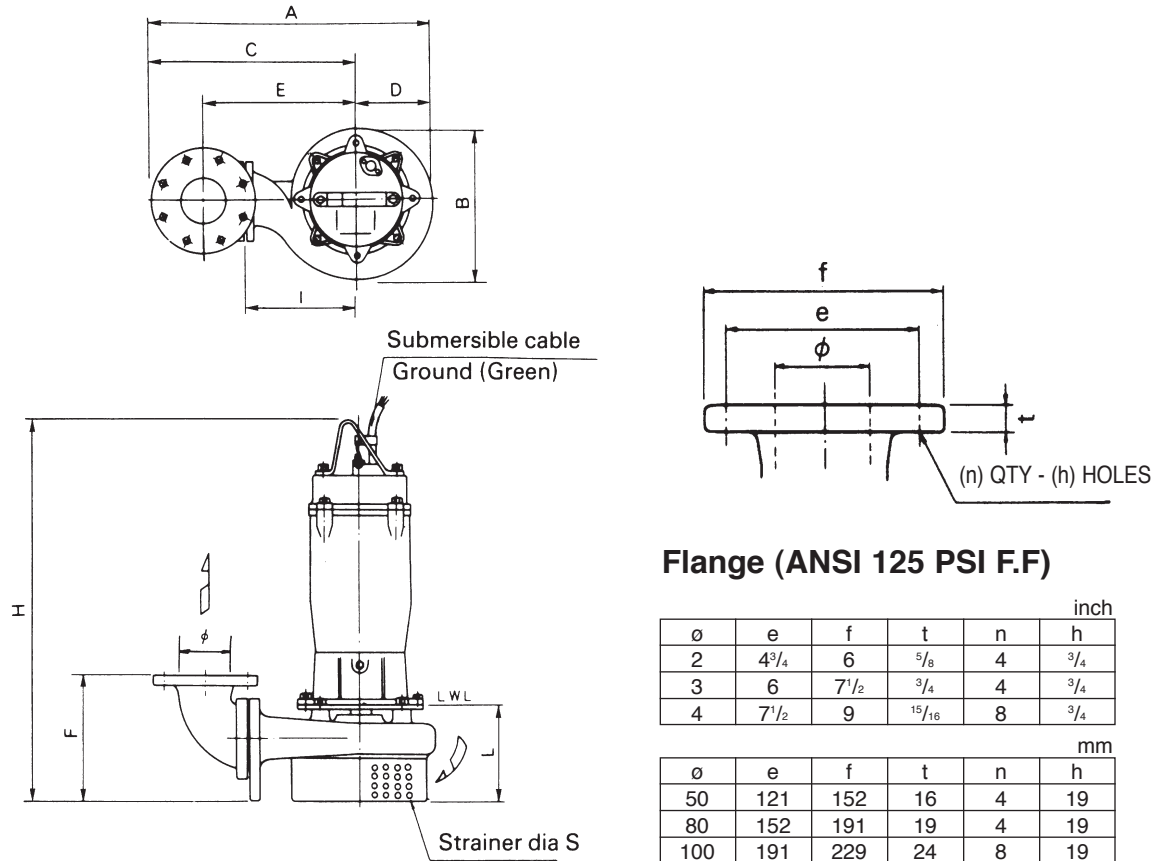
Dimensions: inch

PHASE	SIZE ø	MODEL	OUTPUT		PUMP & MOTOR										WEIGHT Lb
			kW	HP	A	B	C	D	E	F	H	I	L	S	
THREE	2	50CSU62.2	2.2	3	17 ¹ / ₁₆	9 ⁵ / ₈	12 ⁵ / ₁₆	4 ³ / ₄	9 ¹ / ₄	7 ¹³ / ₁₆	27 ¹¹ / ₁₆	7 ¹ / ₁₆	6 ⁵ / ₁₆	3 ³ / ₈	119
		50CSU63.7	3.7	5	17 ¹ / ₁₆	9 ⁵ / ₈	12 ⁵ / ₁₆	4 ³ / ₄	9 ¹ / ₄	7 ¹³ / ₁₆	27 ¹¹ / ₁₆	7 ¹ / ₁₆	6 ⁵ / ₁₆	3 ³ / ₈	130
	3	80CSU62.2	2.2	3	19 ¹³ / ₁₆	10 ⁹ / ₁₆	14 ¹ / ₂	5 ⁵ / ₁₆	10 ¹³ / ₁₆	8 ⁷ / ₁₆	27 ¹⁵ / ₁₆	7 ⁷ / ₈	6 ⁵ / ₁₆	3 ³ / ₈	128
		80CSU63.7	3.7	5	19 ¹³ / ₁₆	10 ⁹ / ₁₆	14 ¹ / ₂	5 ⁵ / ₁₆	10 ¹³ / ₁₆	8 ⁷ / ₁₆	27 ¹⁵ / ₁₆	7 ⁷ / ₈	6 ⁵ / ₁₆	3 ³ / ₈	137
	4	100CSU65.5	5.5	7½	24 ³ / ₁₆	12 ² / ₁₆	18 ¹ / ₈	6 ¹ / ₈	14	10 ¹ / ₈	30 ⁵ / ₈	9 ¹³ / ₁₆	7 ⁷ / ₈	1½	194
		100CSU67.5	7.5	10	24 ³ / ₁₆	12 ² / ₁₆	18 ¹ / ₈	6 ¹ / ₈	14	10 ¹ / ₈	30 ⁵ / ₈	9 ¹³ / ₁₆	7 ⁷ / ₈	1½	203

Dimensions: mm

PHASE	SIZE ø	MODEL	OUTPUT		PUMP & MOTOR										WEIGHT kg
			kW	HP	A	B	C	D	E	F	H	I	L	S	
THREE	50	50CSU62.2	2.2	3	433	245	313	120	235	198	703	180	160	10	54
		50CSU63.7	3.7	5	433	245	313	120	235	198	703	180	160	10	59
	80	80CSU62.2	2.2	3	503	268	368	135	275	215	709	200	160	10	58
		80CSU63.7	3.7	5	503	268	368	135	275	215	709	200	160	10	62
	100	100CSU65.5	5.5	7½	615	309	460	155	355	257	778	250	200	13	88
		100CSU67.5	7.5	10	615	309	460	155	355	257	778	250	200	13	92

Model CSHU
EBARA PRO Cast Sump Pumps
Sectional View

Hot Water Pumps

1/2 to 2 HP

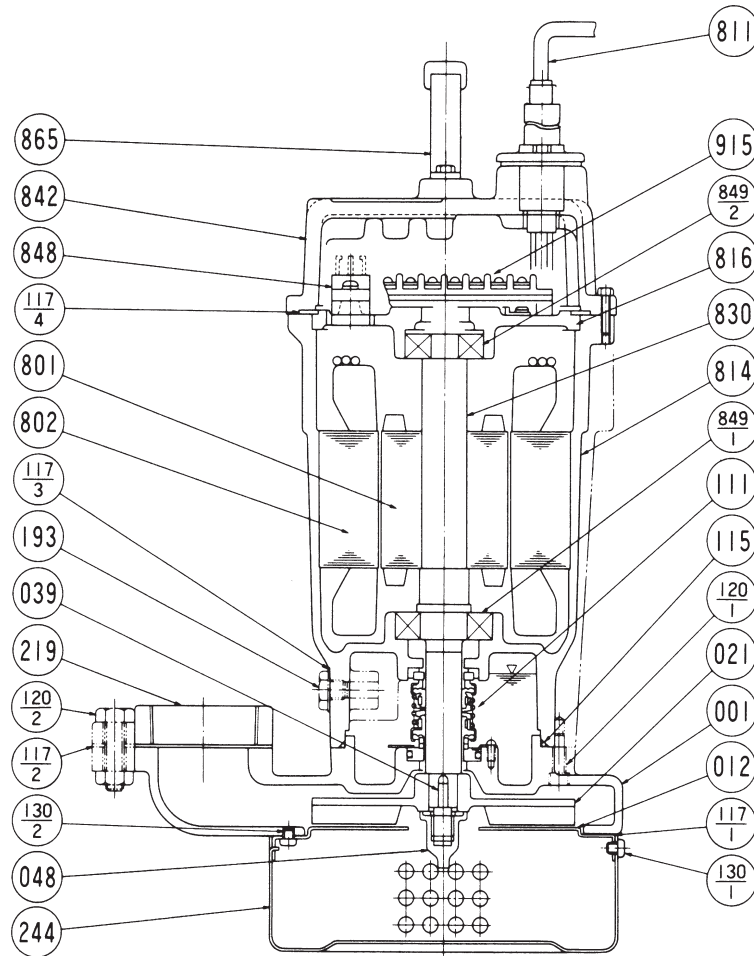

Motors purchased as a complete unit.

PART NO.	PART NAME	MATERIAL	ASTM, AISI CODE	NO. FOR 1 UNIT	PART NO.	PART NAME	MATERIAL	ASTM, AISI CODE	NO. FOR 1 UNIT
001	CASING	CAST IRON	A48 Class 30	1	193	OIL PLUG	BRASS	B36 No. 272	1
012	SUCTION COVER	304 STAINLESS	AISI304	1	219	COMPANION FLANGE	CAST IRON	A48 Class 30	1
†021	IMPELLER	CAST IRON	A48 Class 30	1	244	STRAINER	STEEL	A283 Grade D	1
039	KEY	420 STAINLESS	AISI420	1	801	ROTOR	—		1
048	IMPELLER NUT	BRASS	B36 No. 272	1	802	STATOR	—		1
†111	MECHANICAL SEAL	—		1 SET	†811	SUBMERSIBLE CABLE	—		1
†115	O-RING	RUBBER (NBR)		1	814	MOTOR FRAME	CAST IRON	A48 Class 30	1
†117-1	GASKET	PRESS BOARD		1	816	BRACKET	CAST IRON	A48 Class 30	1
†117-2	GASKET	RUBBER (CR or NBR)		1	830	SHAFT	403 STAINLESS	AISI403	1
†117-3	GASKET			1	842	MOTOR COVER	CAST IRON	A48 Class 30	1
†117-4	GASKET (MODEL CSU)	RUBBER (NBR)		1	848	MOTOR PROTECTOR	—		1
	O-RING (MODEL CSHU)	RUBBER (NBR)		1	†849-1	BALL BEARING	—		1
120-1	BOLT	304 STAINLESS	AISI304	3 or 4	† 849-2	BALL BEARING	—		1
120-2	BOLTS	304 STAINLESS	AISI304	2	865	HANDLE	304 STAINLESS	AISI304	1
130-1	SCREW	304 STAINLESS	AISI304	1	915	EXTERNAL TERMINAL	—		1~2
130-2	SCREW	304 STAINLESS	AISI304	3 or 4					

†: Recommended spare parts.

EBARA Fluid Handling
www.pumpsebara.com

(t) 803 327-5005 • (f) 803 327-5097

Model CSU, CSHU
EBARA PRO Cast Sump Pumps
Sectional View
Model CSU

3 to 10 HP

Model CSHU

Hot Water Pumps

3 to 5 HP

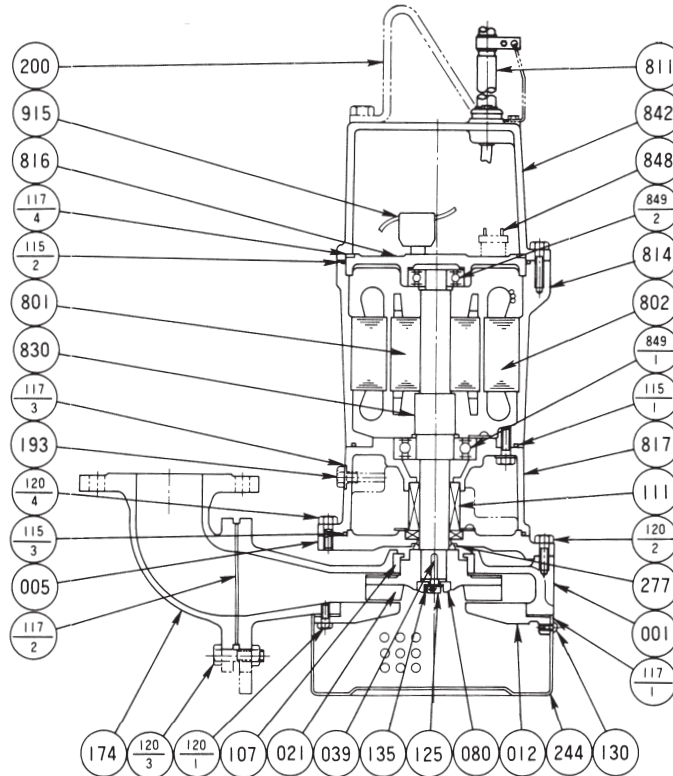
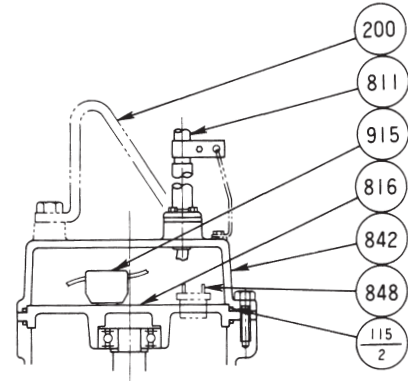
3-5HP

7½, 10HP

Motors purchased as a complete unit.
 Parts No. 915 is not installed for Model CSHU.
 Parts No. 117-4 is not installed, No. 115-2 is installed 2 pcs. for 7½-10HP.

PART NO.	PART NAME	MATERIAL	ASTM, AISI CODE	NO. FOR 1 UNIT
001	CASING	CAST IRON	A48 Class 30	1
005	INTERMEDIATE CASING	CAST IRON	A48 Class 30	1
012	SUCTION COVER	CAST IRON	A48 Class 30	1
†021	IMPELLER	DUCTILE IRON	A536 GR60-40-18	1
039	KEY	420 STAINLESS	AISI420	1
080	BUSHING	STEEL	A283 Grade D	1
†107	WEARING RING	304 STAINLESS	AISI 304	1
†111	MECHANICAL SEAL	—		1 SET
†115-1	O-RING	RUBBER (NBR)		1
†115-2	O-RING	RUBBER (NBR)		1 or 2
†115-3	O-RING	RUBBER (NBR)		1
†117-1	GASKET	PRESS BOARD		1
†117-2	GASKET			1
†117-3	GASKET			1
†117-4	GASKET	RUBBER (NBR)		1
120-1	BOLT	304 STAINLESS	AISI304	4
120-2	BOLT	304 STAINLESS	AISI304	4
120-3	BOLT	304 STAINLESS	AISI304	4
120-4	BOLT	304 STAINLESS	AISI304	2
125	BOLT	304 STAINLESS	AISI304	1

PART NO.	PART NAME	MATERIAL	ASTM, AISI CODE	NO. FOR 1 UNIT
130	SCREW	304 STAINLESS	AISI304	2
135	WASHER	304 STAINLESS	AISI304	1
174	DISCHARGE ELBOW	CAST IRON	A48 Class 30	1
193	OIL PLUG	BRASS	B36 No. 272	1
200	LIFTING HANGER	STEEL	A283 Grade D	1
244	STRAINER	STEEL	A283 Grade D	1
277	"V" RING	RUBBER (NBR)		1
801	ROTOR	—		1
802	STATOR	—		1
†811	SUBMERSIBLE CABLE	—		1
814	MOTOR FRAME	CAST IRON	A48 Class 30	1
816	BRACKET	CAST IRON	A48 Class 30	1
817	BRACKET	CAST IRON	A48 Class 30	1
830	SHAFT	403 STAINLESS	AISI403	1
842	MOTOR COVER	CAST IRON	A48 Class 30	1
848	MOTOR PROTECTOR	—		1
†849-1	BALL BEARING	—		1
†849-2	BALL BEARING	—		1
915	EXTERNAL TERMINAL			1

†: Recommended spare parts.