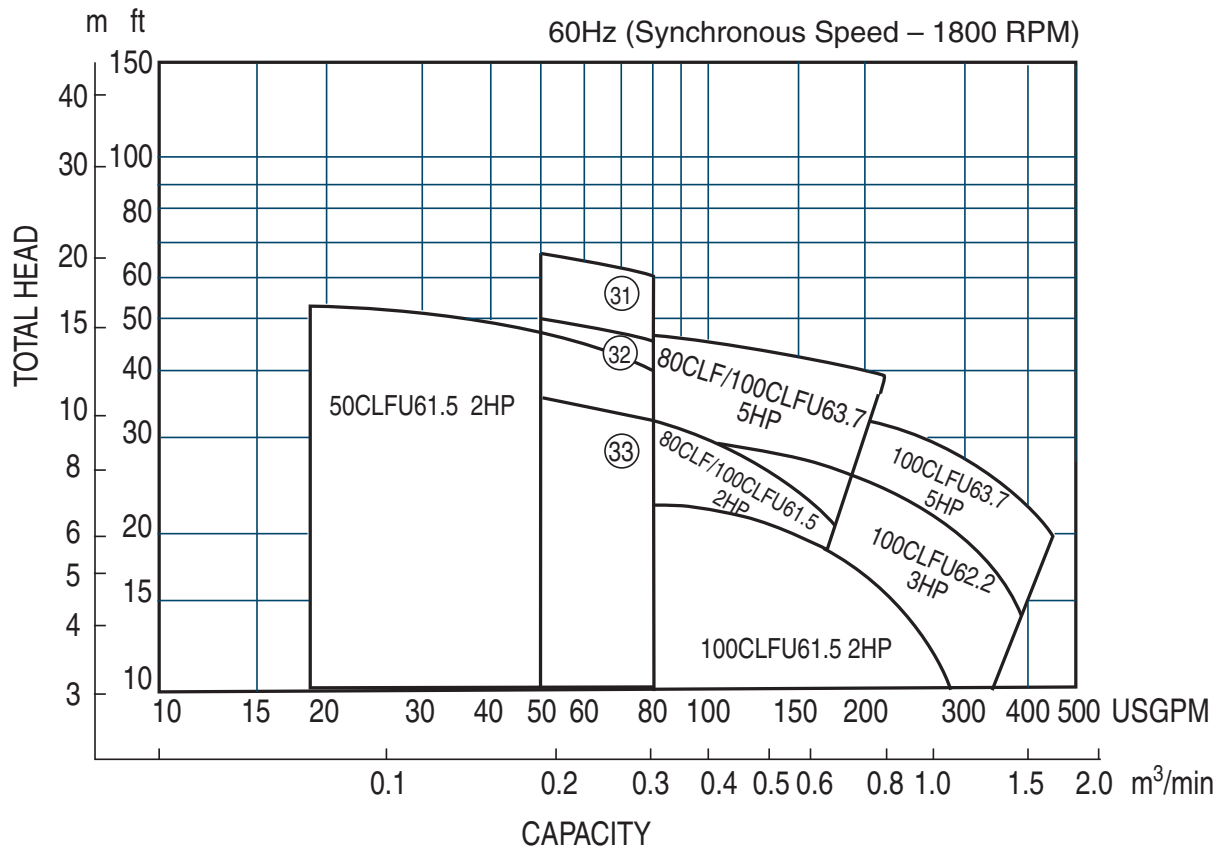
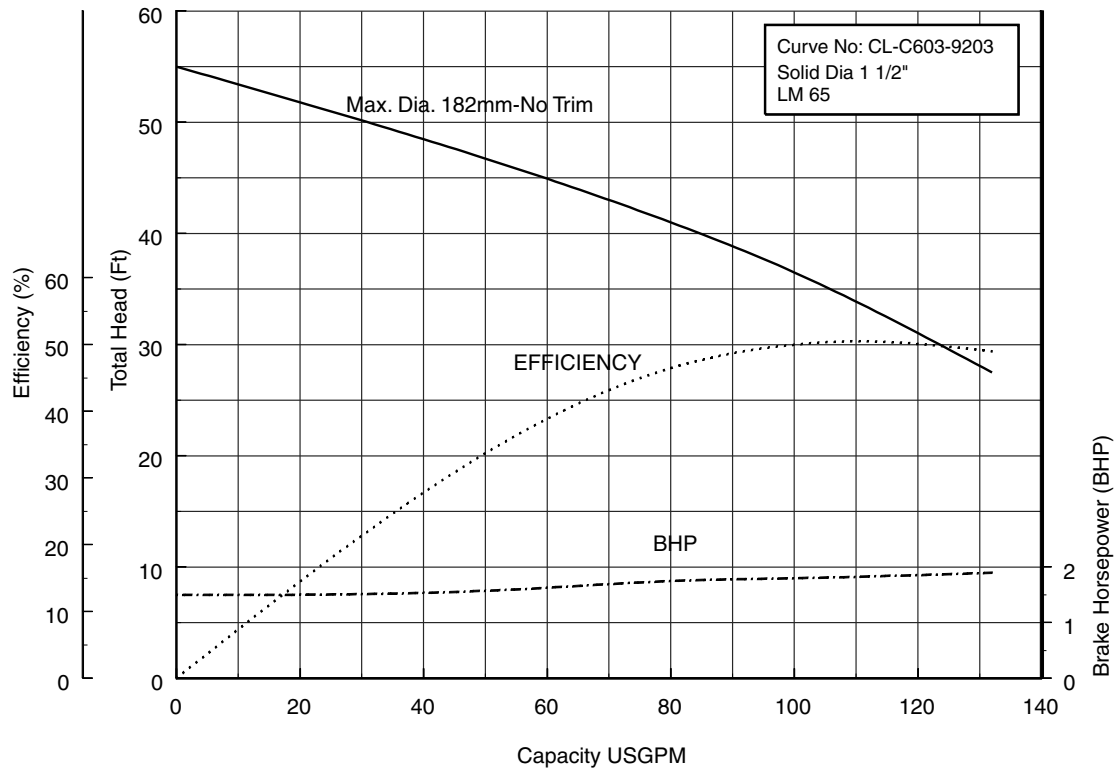
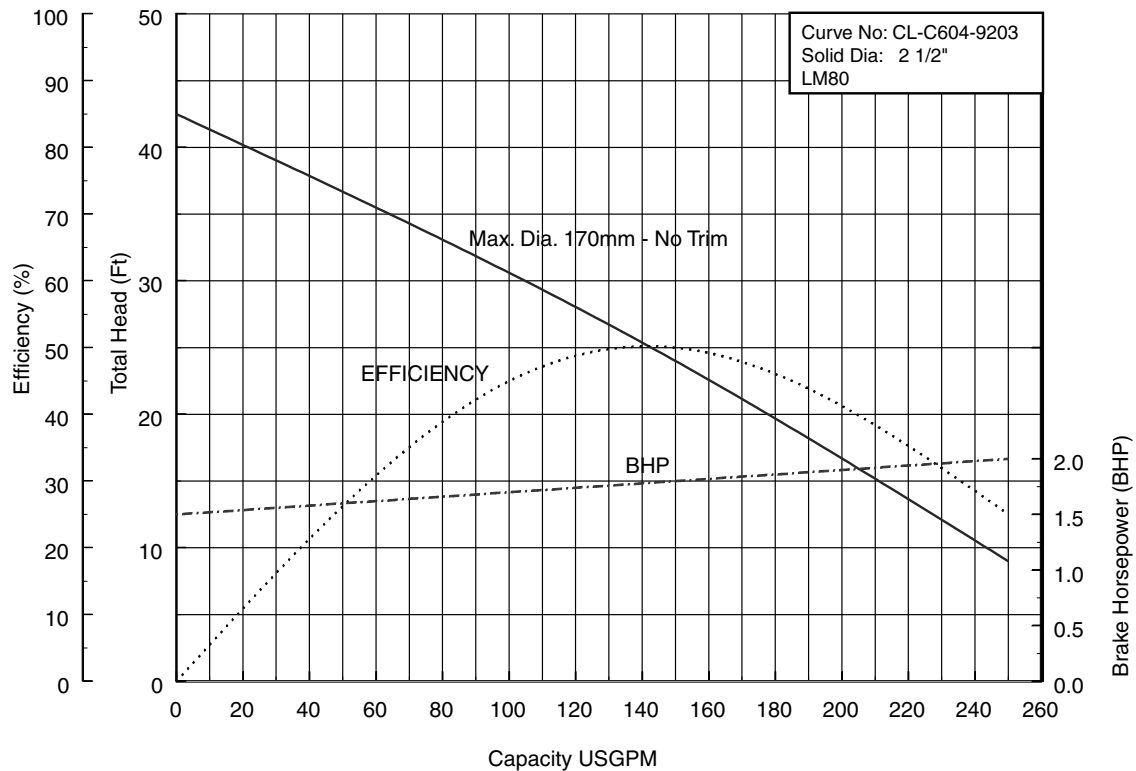
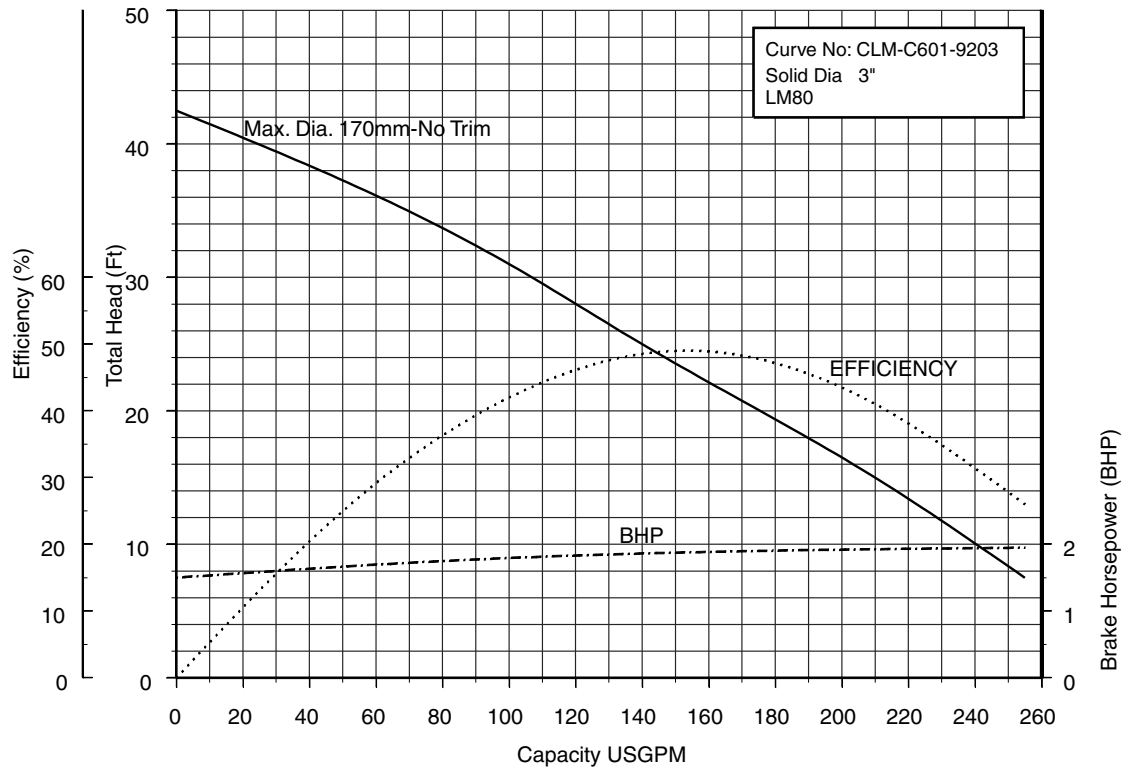
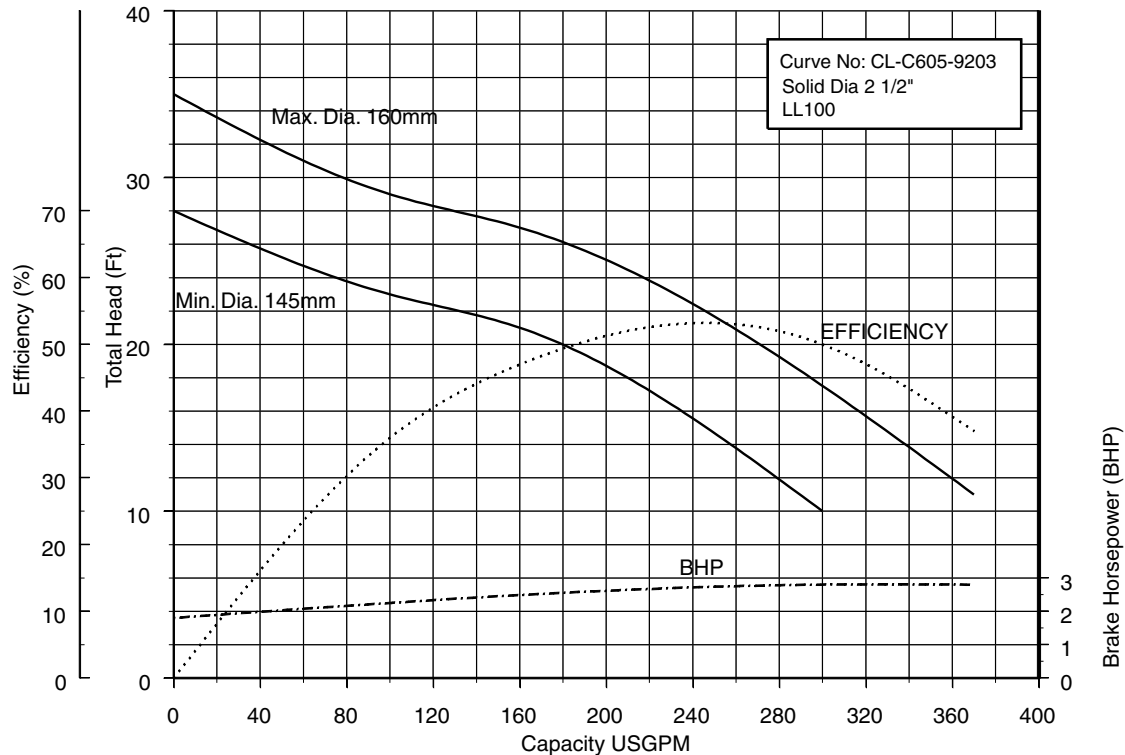
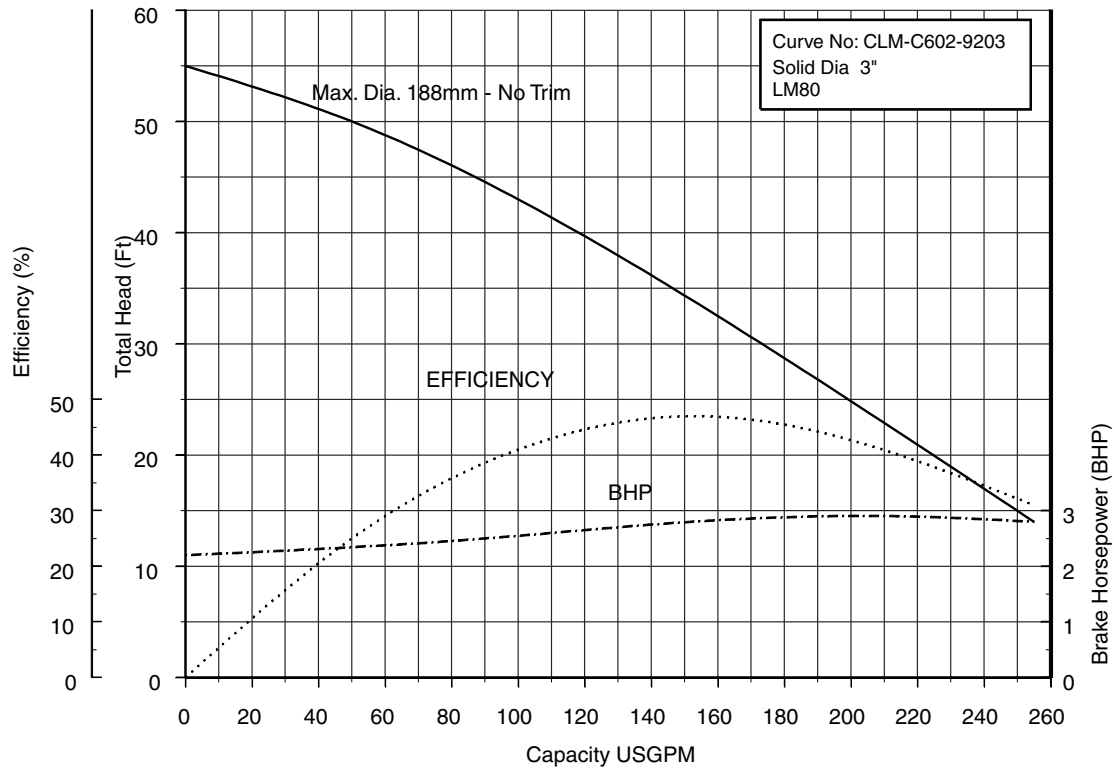
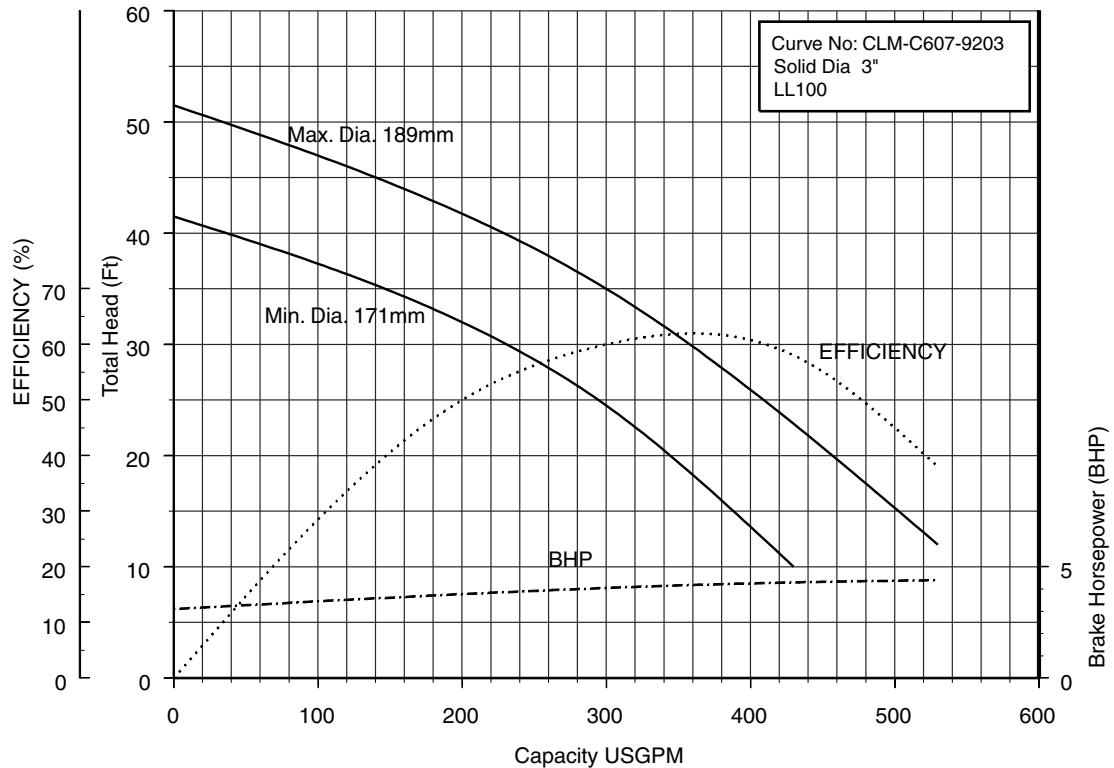

Three Phase 60Hz

31	80CLMFU63.7	5HP
32	80CLMFU62.2	3HP
33	80CLMFU61.5	2HP

50CLF61.5 (2HP) Synchronous Speed: 1800 RPM
2, 3 inch Discharge

80CLF61.5 (2HP) Synchronous Speed: 1800 RPM
3, 4 inch Discharge

80CLMF61.5 (2HP) Synchronous Speed: 1800 RPM
3, 4 inch Discharge

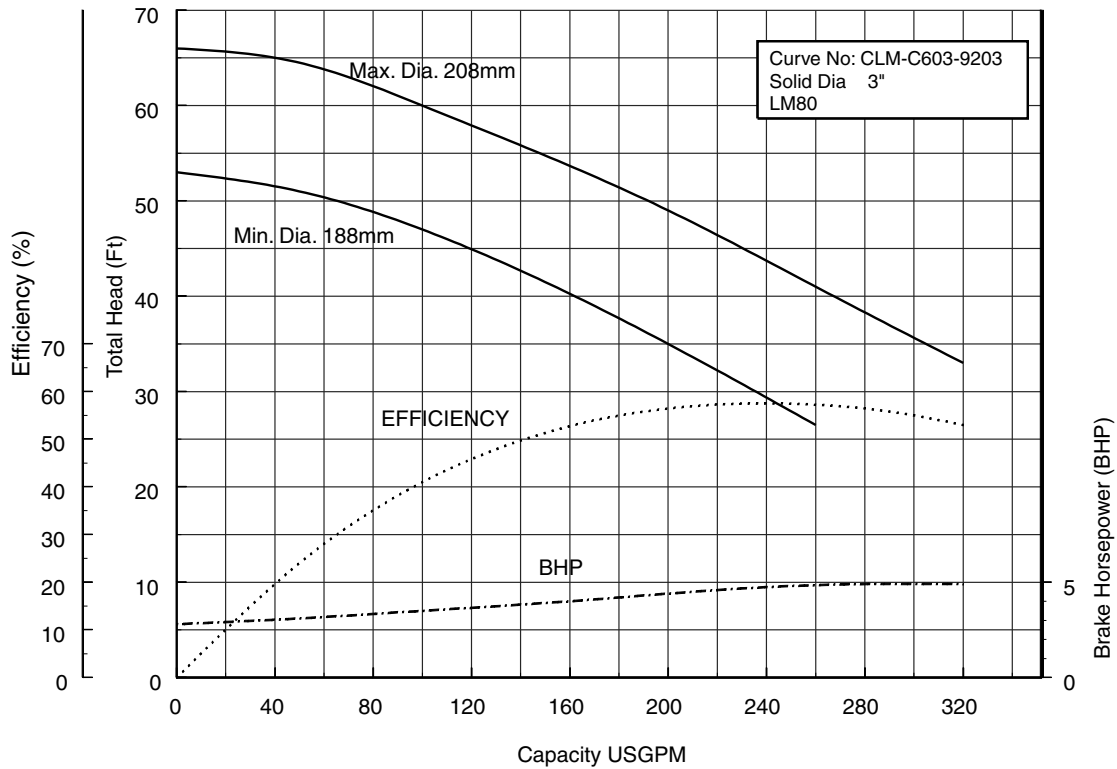
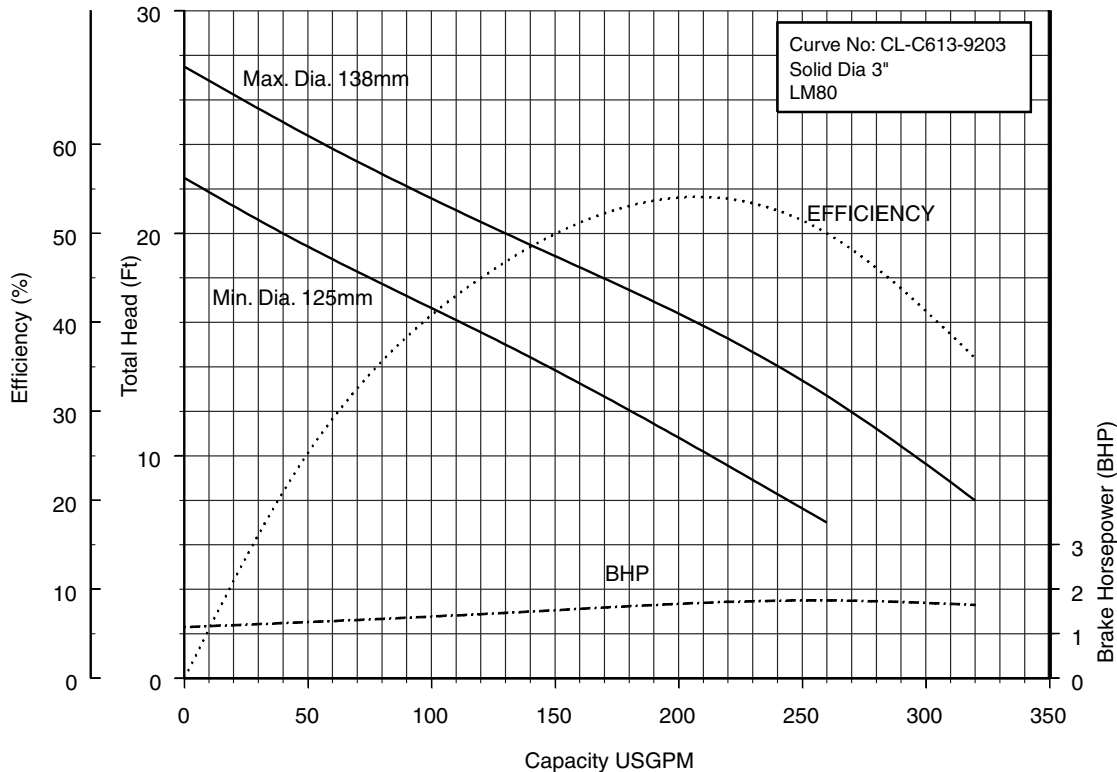
80CLF62.2 (3HP) Synchronous Speed: 1800 RPM
3, 4 inch Discharge

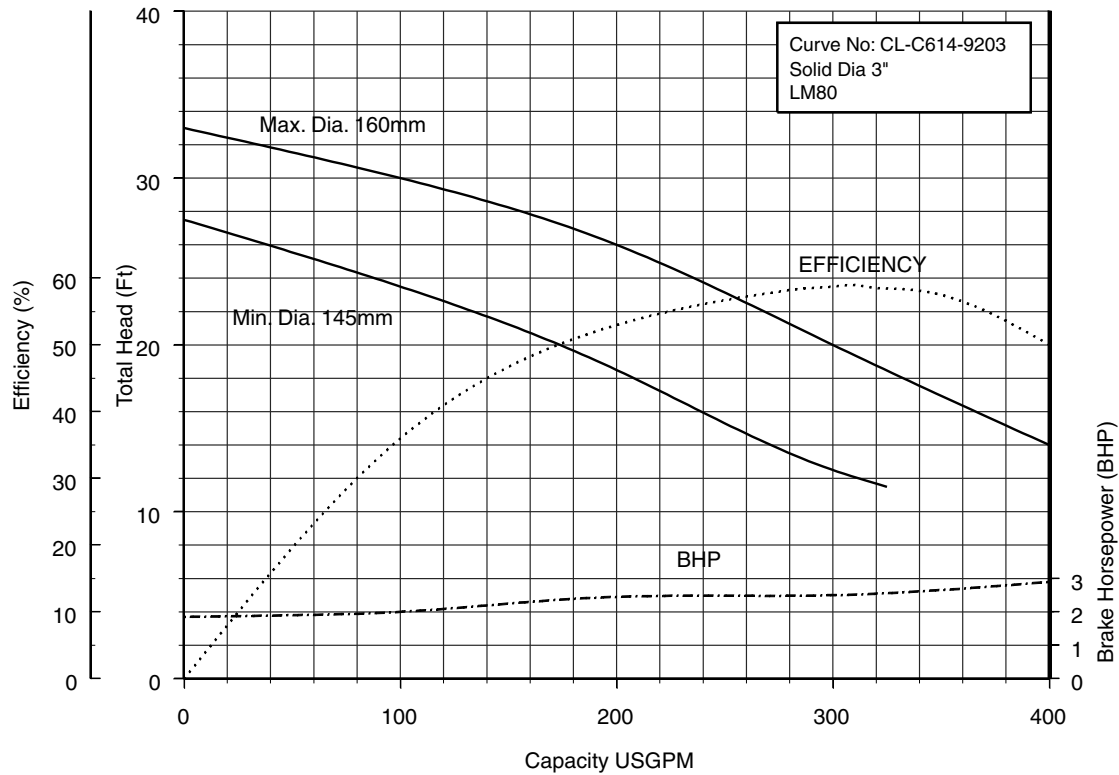
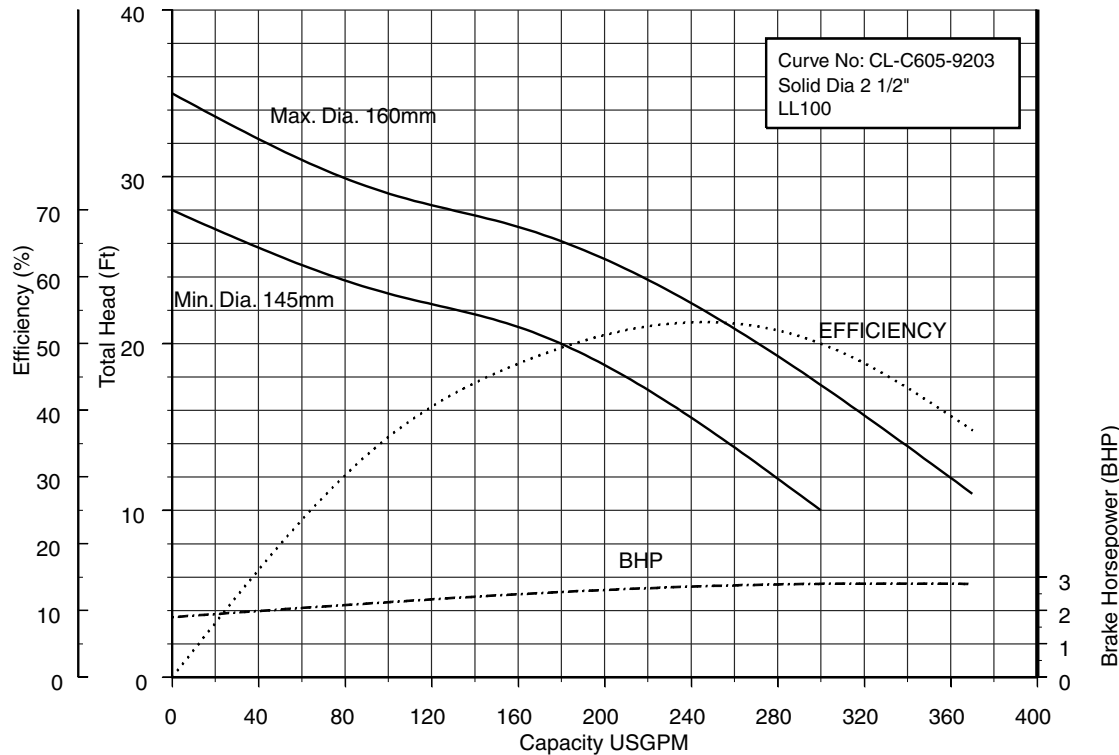
80CLMF62.2 (3HP) Synchronous Speed: 1800 RPM
3, 4 inch Discharge

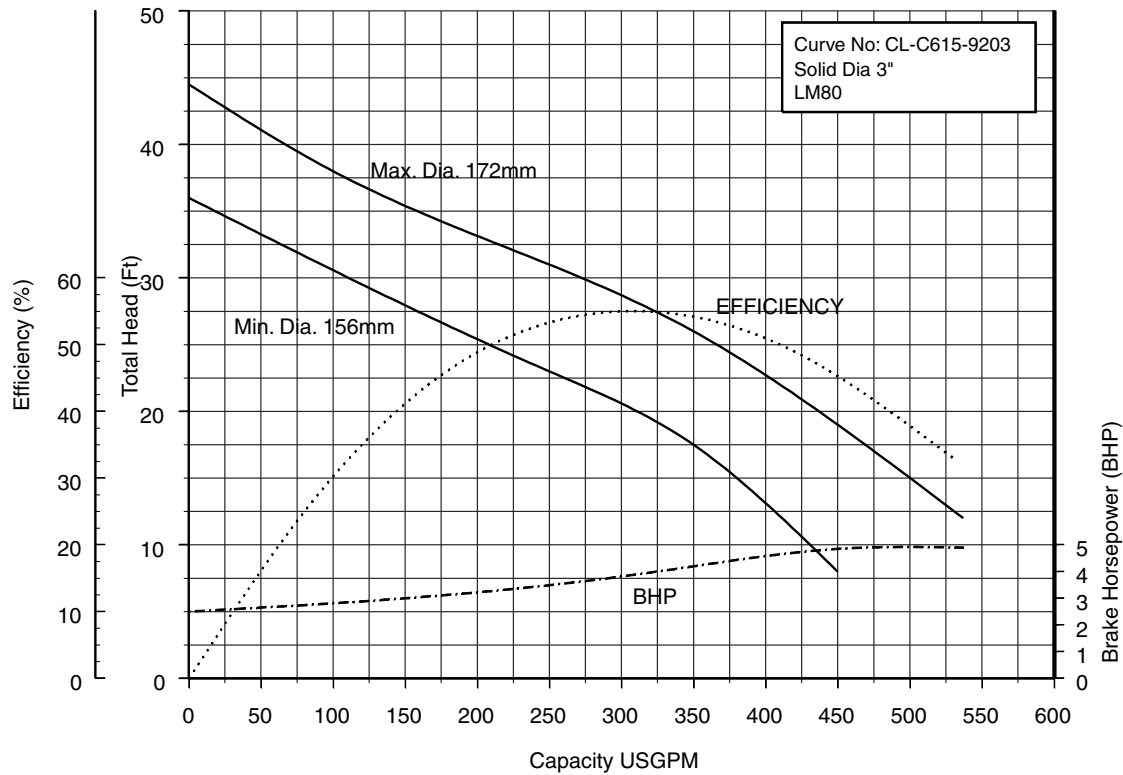
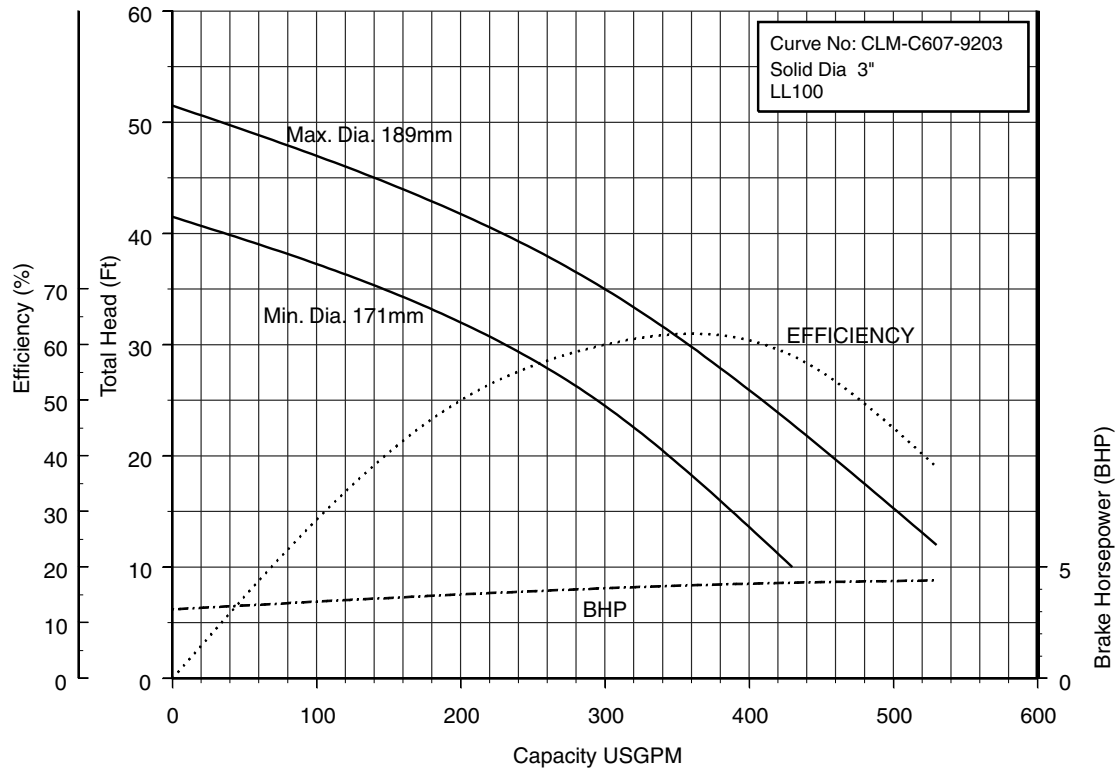
80CLF63.7 (5HP) Synchronous Speed: 1800 RPM
3, 4 inch Discharge

80CLMF63.7 (5HP) Synchronous Speed: 1800 RPM
3, 4 inch Discharge

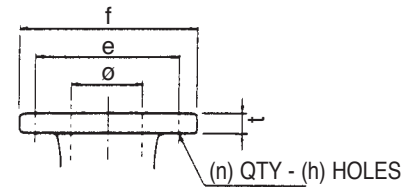
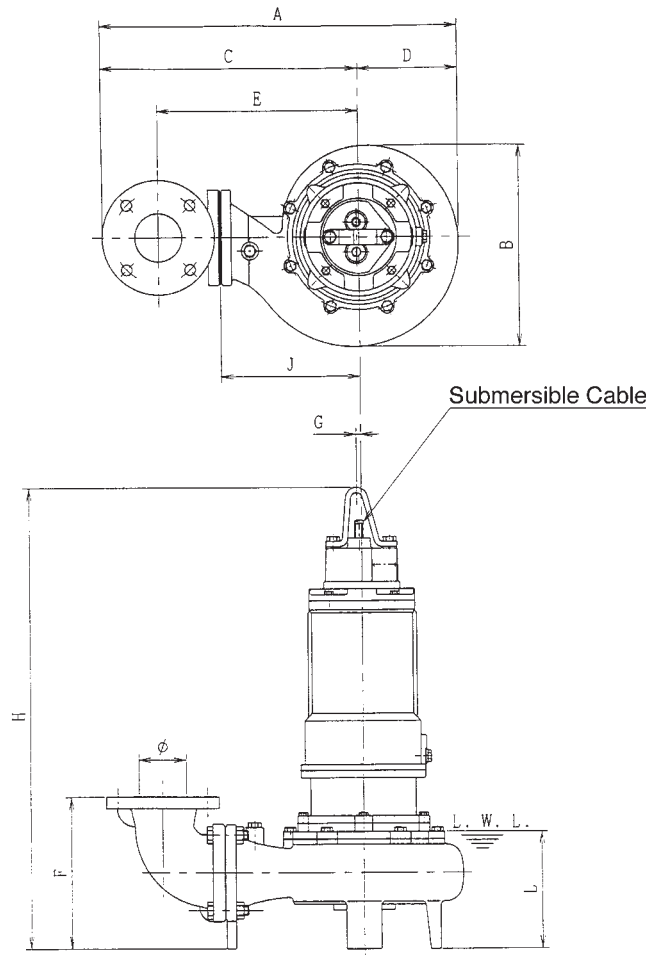
100CLF61.5 (2HP) Synchronous Speed: 1800 RPM
3, 4 inch Discharge

100CLF62.2 (3HP) Synchronous Speed: 1800 RPM
3, 4 inch Discharge

100CLMF62.2 (3HP) Synchronous Speed: 1800 RPM
3, 4 inch Discharge

100CLF63.7 (5HP) Synchronous Speed: 1800 RPM
3, 4 inch Discharge

100CLMF63.7 (5HP) Synchronous Speed: 1800 RPM
3, 4 inch Discharge

Model CLFU
EBARA PRO Cast Sewage Pumps
Dimensions
Model CLFU
50CLFU, 2HP
80CLFU, 2 to 5HP

Flange (ANSI 125 PSI F.F)

inch					
ø	e	f	t	n	h
2	4 ³ / ₄	6	⁵ / ₈	4	³ / ₄
3	6	7 ¹ / ₂	³ / ₄	4	³ / ₄

mm					
ø	e	f	t	n	h
50	121	152	16	4	19
80	152	191	19	4	19

Dimensions: inch

PHASE	SIZE ø	MODEL	OUTPUT		PUMP & MOTOR										WEIGHT Lb
			kW	HP	A	B	C	D	E	F	G	H	J	L	
THREE	2/3	50DLFU61.5	1.5	2	17 ¹¹ / ₁₆	10 ¹ / ₈	12 ⁵ / ₈	5 ¹ / ₁₆	9 ⁵ / ₈	7 ⁷ / ₈	⁵ / ₁₆	27 ¹¹ / ₁₆	7 ¹ / ₁₆	6 ⁵ / ₁₆	132
		80DLFU61.5	1.5	2	20 ³ / ₄	11 ¹ / ₂	15	5 ³ / ₄	11 ¹ / ₄	8 ¹¹ / ₁₆	⁵ / ₁₆	28 ¹ / ₂	8 ¹ / ₄	7 ¹ / ₁₆	148
	3/4	80DLFU62.2	2.2	3	23 ¹³ / ₁₆	13 ³ / ₁₆	17 ³ / ₁₆	6 ⁵ / ₈	13 ³ / ₈	9 ¹³ / ₁₆	⁵ / ₁₆	30 ¹ / ₄	9 ¹ / ₄	8 ¹ / ₁₆	209
		80DLFU63.7	3.7	5	23 ¹³ / ₁₆	13 ³ / ₁₆	17 ³ / ₁₆	6 ⁵ / ₈	13 ³ / ₈	9 ¹³ / ₁₆	⁵ / ₁₆	31 ¹³ / ₁₆	9 ¹ / ₄	8 ¹ / ₁₆	209

Dimensions: mm

PHASE	SIZE ø	MODEL	OUTPUT		PUMP & MOTOR										WEIGHT kg
			kW	HP	A	B	C	D	E	F	G	H	J	L	
THREE	50/80	50DLFU61.5	1.5	2	450	257	321	129	245	200	8	703	180	160	60
		80DLFU61.5	1.5	2	527	292	381	146	285	220	8	724	210	180	67
	80/100	80DLFU62.2	2.2	3	605	335	436	169	340	250	8	768	235	205	95
		80DLFU63.7	3.7	5	605	335	436	169	340	250	8	808	235	205	95

***Note:** All 80DLFU dimensions are based on 3" discharge.

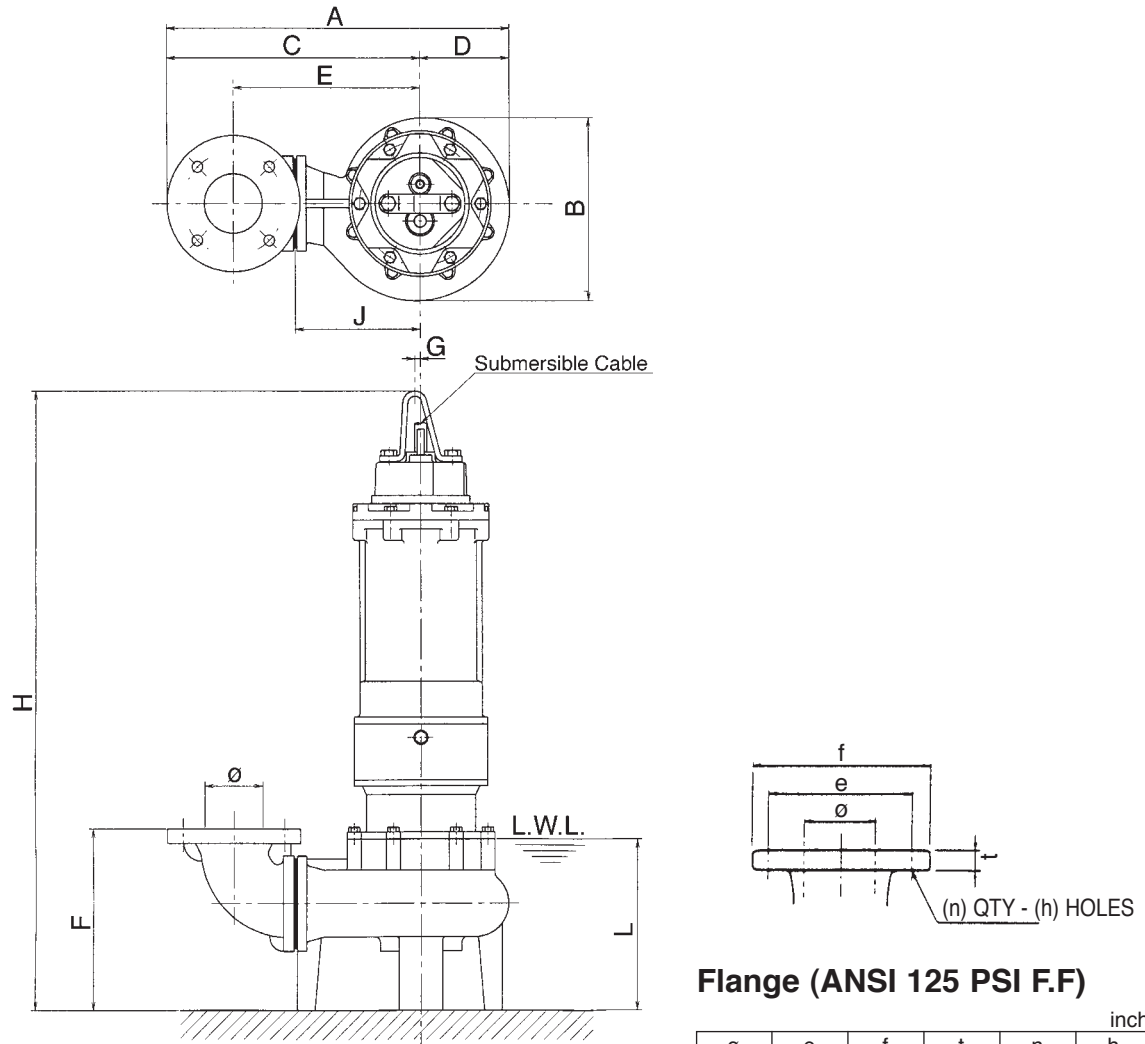
Flange (ANSI 125 PSI F.F)

inch					
Ø	e	f	t	n	h
3	6	7½	¾	4	¾
mm					
Ø	e	f	t	n	h
80	152	191	19	4	19

Dimensions: inch

PHASE	SIZE Ø	MODEL	OUTPUT		PUMP & MOTOR										WEIGHT Lb
			kW	HP	A	B	C	D	E	F	G	H	J	L	
THREE	2/3	80CLMFU61.5	1.5	2	20¾	11½	15	5¾	11¼	8 ¹¹ / ₁₆	⁵ / ₁₆	28½	8¼	7 ¹ / ₁₆	157
		80CLMFU62.2	2.2	3	20¾	11½	15	5¾	11¼	8 ¹¹ / ₁₆	⁵ / ₁₆	29½	8¼	7½	188
		80CLMFU63.7	3.7	5	21 ⁷ / ₁₆	12 ⁷ / ₈	15 ³ / ₈	6 ¹ / ₁₆	11 ⁵ / ₈	8 ¹¹ / ₁₆	⁵ / ₁₆	31 ¹ / ₁₆	8 ¹¹ / ₁₆	7½	206

Dimensions: mm

PHASE	SIZE Ø	MODEL	OUTPUT		PUMP & MOTOR										WEIGHT kg
			kW	HP	A	B	C	D	E	F	G	H	J	L	
THREE	80/100	80CLMFU61.5	1.5	2	527	292	381	146	285	220	8	724	210	180	71
		80CLMFU62.2	2.2	3	527	292	381	146	285	220	8	750	210	190	85
		80CLMFU63.7	3.7	5	545	308	391	154	295	220	8	789	220	190	93

***Note:** All 80DLFU dimensions are based on 3" discharge.

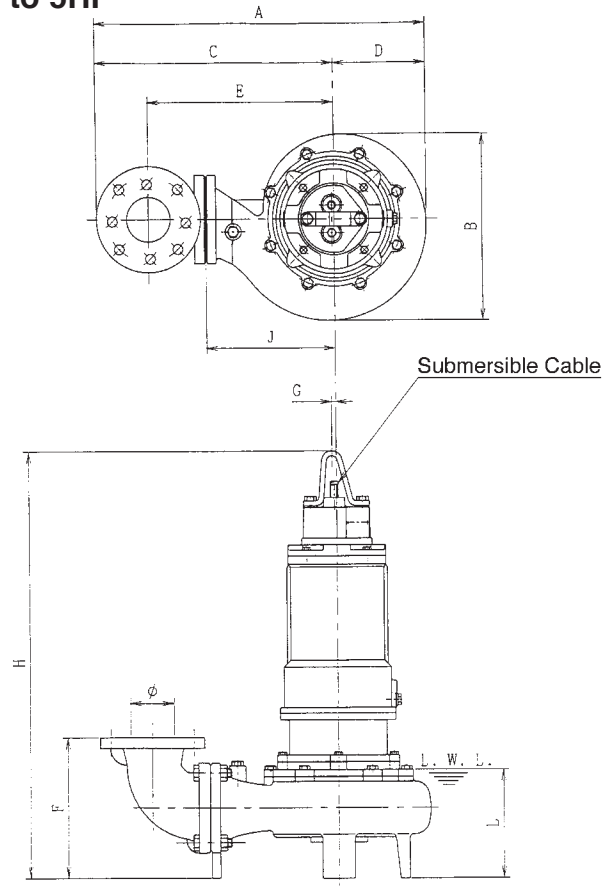
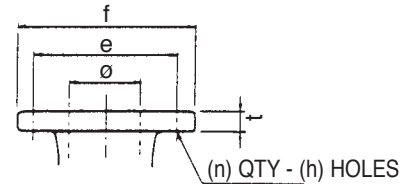
Model CLFU
EBARA PRO Cast Sewage Pumps
Dimensions
100CLFU, 2 to 5HP

Flange (ANSI 125 PSI F.F)

inch					
ø	e	f	t	n	h
4	7 ¹ / ₂	9	¹⁵ / ₁₆	8	³ / ₄

mm					
ø	e	f	t	n	h
100	191	229	24	8	19

Dimensions: inch

PHASE	SIZE ø	MODEL	OUTPUT		PUMP & MOTOR								WEIGHT Lb		
			KW	HP	A	B	C	D	E	F	G	H		J	L
THREE	3/4	100CLFU61.5	1.5	2	21 ³ / ₄	10 ¹ / ₂	16 ⁹ / ₁₆	5 ¹ / ₄	12	10 ¹³ / ₁₆	⁵ / ₁₆	29 ¹⁵ / ₁₆	7 ⁷ / ₈	8 ¹¹ / ₁₆	170
		100CLFU62.2	2.2	3	22 ⁷ / ₈	11 ¹ / ₈	17 ⁹ / ₁₆	5 ⁹ / ₁₆	12 ¹³ / ₁₆	10 ¹³ / ₁₆	⁵ / ₁₆	30 ¹³ / ₁₆	8 ¹¹ / ₁₆	8 ¹¹ / ₁₆	198
		100CLFU63.7	3.7	5	22 ⁷ / ₈	11 ¹ / ₈	17 ⁹ / ₁₆	5 ⁹ / ₁₆	12 ¹³ / ₁₆	10 ¹³ / ₁₆	⁵ / ₁₆	32 ³ / ₈	8 ¹¹ / ₁₆	8 ¹¹ / ₁₆	216
	4/6	100CLFU67.5	7.5	10	28 ⁹ / ₁₆	15 ¹¹ / ₁₆	20 ¹¹ / ₁₆	7 ⁷ / ₈	16 ¹ / ₈	15	³ / ₈	37 ⁷ / ₁₆	11	11 ⁷ / ₁₆	395
		100CLFU611	11	15	28 ⁹ / ₁₆	15 ¹¹ / ₁₆	20 ¹¹ / ₁₆	7 ⁷ / ₈	16 ¹ / ₈	15	⁵ / ₁₆	41 ¹ / ₈	11	11 ⁷ / ₁₆	476
		100CLFU615	15	20	29 ³ / ₄	16 ⁷ / ₁₆	21 ⁷ / ₁₆	8 ¹ / ₄	16 ¹⁵ / ₁₆	14 ¹³ / ₁₆	⁵ / ₁₆	43 ¹ / ₄	11 ¹³ / ₁₆	11 ¹³ / ₁₆	602
		100CLFU618	18.5	25	30 ⁷ / ₈	17 ¹ / ₄	22 ¹ / ₄	8 ¹¹ / ₁₆	17 ¹¹ / ₁₆	14 ¹³ / ₁₆	⁵ / ₁₆	44 ¹³ / ₁₆	12 ⁵ / ₈	11 ¹³ / ₁₆	677
	3/4	100CLFU622	22	30	30 ⁷ / ₈	17 ¹ / ₄	22 ¹ / ₄	8 ¹¹ / ₁₆	17 ¹¹ / ₁₆	14 ¹³ / ₁₆	⁵ / ₁₆	44 ¹³ / ₁₆	12 ⁵ / ₈	11 ¹³ / ₁₆	736
		100CLFU630	30	40	33 ¹ / ₄	19 ⁹ / ₁₆	23 ⁵ / ₈	9 ⁵ / ₈	19 ⁷ / ₈	19 ⁷ / ₁₆	⁵ / ₁₆	55 ³ / ₄	14 ³ / ₁₆	19 ¹ / ₄	1001
		100CLFU637	37	50	33 ¹ / ₄	19 ⁹ / ₁₆	23 ⁵ / ₈	9 ⁵ / ₈	19 ⁷ / ₈	19 ⁷ / ₁₆	⁵ / ₁₆	59 ⁹ / ₁₆	14 ³ / ₁₆	20 ⁵ / ₁₆	1171

Dimensions: mm

PHASE	SIZE ø	MODEL	OUTPUT		PUMP & MOTOR								WEIGHT kg		
			KW	HP	A	B	C	D	E	F	G	H		J	L
THREE	80/100	100CLFU61.5	1.5	2	553	267	420	134	305	275	8	760	200	220	77
		100CLFU62.2	2.2	3	581	282	440	141	325	275	8	782	220	220	90
		100CLFU63.7	3.7	5	581	282	440	141	325	275	8	822	220	220	98
	100/150	100CLFU67.5	7.5	10	725	398	525	200	410	381	10	951	280	290	179
		100CLFU611	11	15	725	398	525	200	410	381	8	1044	280	290	216
		100CLFU615	15	20	755	417	545	210	430	377	8	1099	300	300	273
		100CLFU618	18.5	25	784	438	565	220	450	377	8	1139	320	300	307
	80/100	100CLFU622	22	30	784	438	565	220	450	377	8	1139	320	300	334
		100CLFU630	30	40	845	497	600	245	485.5	493	8	1416	360	490	454
		100CLFU637	37	50	845	497	600	245	485.5	493	8	1506	360	516	531

***Note:** All dimensions are based on 4" discharge.

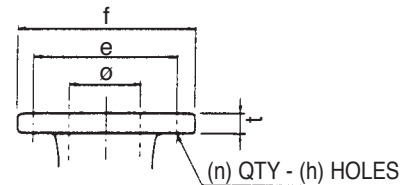
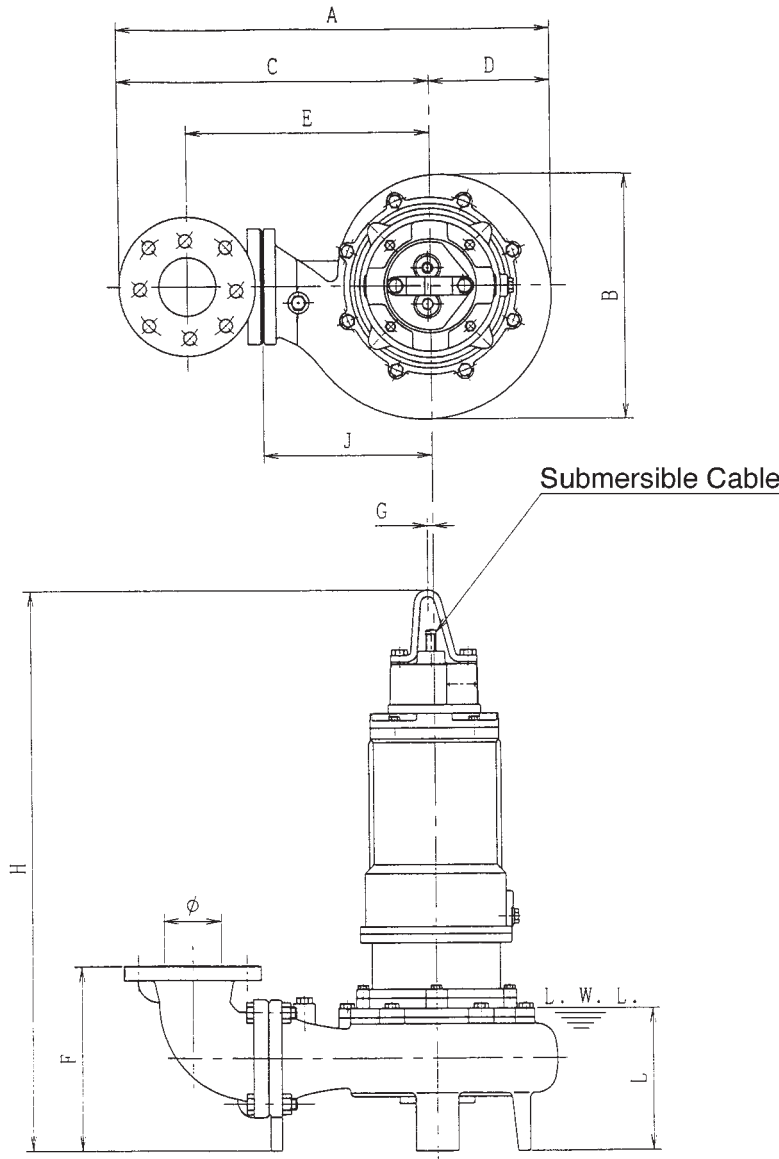
Flange (ANSI 125 PSI F.F)

inch					
ø	e	f	t	n	h
4	7 ¹ / ₂	9	¹⁵ / ₁₆	8	³ / ₄

mm					
ø	e	f	t	n	h
100	191	229	24	8	19

Dimensions: inch

PHASE	SIZE ø	MODEL	OUTPUT		PUMP & MOTOR										WEIGHT Lb
			kW	HP	A	B	C	D	E	F	G	H	J	L	
THREE	3/4	100CLMFU62.2	2.2	3	24 ⁹ / ₁₆	13 ³ / ₁₆	17 ¹⁵ / ₁₆	6 ⁵ / ₈	13 ³ / ₈	9 ¹³ / ₁₆	⁵ / ₁₆	30 ¹ / ₄	9 ¹ / ₄	8 ¹ / ₁₆	210
		100CLMFU63.7	3.7	5	24 ⁹ / ₁₆	13 ³ / ₁₆	17 ¹⁵ / ₁₆	6 ⁵ / ₈	13 ³ / ₈	9 ¹³ / ₁₆	⁵ / ₁₆	31 ¹³ / ₁₆	9 ¹ / ₄	8 ¹ / ₁₆	210

Dimensions: mm

PHASE	SIZE ø	MODEL	OUTPUT		PUMP & MOTOR										WEIGHT kg
			kW	HP	A	B	C	D	E	F	G	H	J	L	
THREE	80/100	100CLMFU62.2	2.2	3	624	335	455	169	340	250	8	768	235	205	95
		100CLMFU63.7	3.7	5	624	335	455	169	340	250	8	808	235	205	95

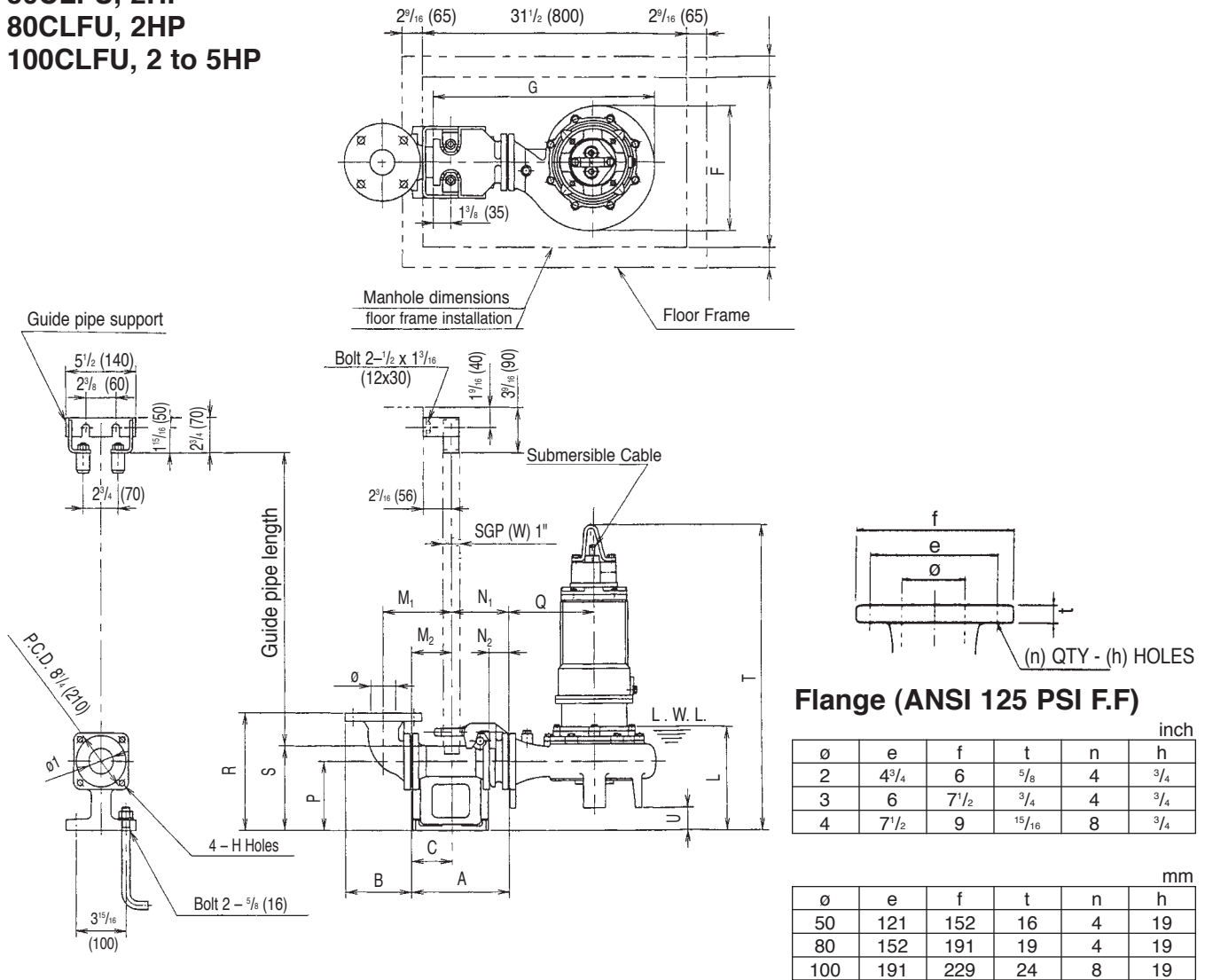
Model CLFU
EBARA PRO Cast Sewage Pumps
Dimensions
Model CLFU with Quick Discharge Connector
50CLFU, 2HP
80CLFU, 2HP
100CLFU, 2 to 5HP

Flange (ANSI 125 PSI F.F)

inch					
ø	e	f	t	n	h
2	4 ^{3/4}	6	5 ^{5/8}	4	3 ^{3/4}
3	6	7 ^{1/2}	3 ^{3/4}	4	3 ^{3/4}
4	7 ^{1/2}	9	1 ^{5/16}	8	3 ^{3/4}

mm					
ø	e	f	t	n	h
50	121	152	16	4	19
80	152	191	19	4	19
100	191	229	24	8	19

Dimensions: inch

PHASE	SIZE ø	MODEL	OUTPUT KW	HP	QDC MODEL	QDC											PUMP & MOTOR						WEIGHT Lb			
						A	B	C	H	J	M ₁	M ₂	N ₁	N ₂	P	R	S	ø1	F	G	L	Q	T	U	PUMP	QDC
THREE	2/3	50CLFU61.5	1.5	2	LM65	8 ^{7/16}	6	3 ^{3/4}	1/2	5 ^{1/2}	6 ^{5/16}	3 ^{3/4}	4 ^{3/4}	1 ^{3/4}	5 ^{11/16}	9 ^{5/16}	7 ^{1/2}	2 ^{1/2}	10 ^{1/8}	18 ^{1/4}	8 ^{1/4}	7 ^{1/16}	29 ^{5/8}	1 ^{15/16}	132	31
		80CLFU61.5	1.5	2	LM80	8 ^{7/16}	6 ^{5/8}	3 ^{9/16}	9/16	6 ^{1/8}	6 ^{1/2}	3 ^{9/16}	4 ^{15/16}	1 ^{15/16}	6 ^{7/8}	11 ^{1/4}	9 ^{1/16}	3	11 ^{1/2}	20 ^{1/8}	9 ^{5/8}	8 ^{1/4}	31 ^{1/16}	2 ^{9/16}	148	37
	3/4	100CLFU61.5	1.5	2	LM80	8 ^{7/16}	8 ^{1/4}	3 ^{9/16}	9/16	6 ^{1/8}	7 ^{11/16}	3 ^{9/16}	4 ^{15/16}	1 ^{15/16}	6 ^{7/8}	11 ^{13/16}	9 ^{1/16}	3	10 ^{1/2}	19 ^{1/16}	9 ^{5/8}	7 ^{7/8}	30 ^{7/8}	1	170	37
		100CLFU62.2	2.2	3	LM80	8 ^{7/16}	8 ^{1/4}	3 ^{9/16}	9/16	6 ^{1/8}	7 ^{11/16}	3 ^{9/16}	4 ^{15/16}	1 ^{15/16}	6 ^{7/8}	11 ^{13/16}	9 ^{1/16}	3	11 ^{1/8}	20 ^{1/2}	9 ^{5/8}	8 ^{11/16}	31 ^{3/8}	1	199	37
		100CLFU63.7	3.7	5	LM80	8 ^{7/16}	8 ^{1/4}	3 ^{9/16}	9/16	6 ^{1/8}	7 ^{11/16}	3 ^{9/16}	4 ^{15/16}	1 ^{15/16}	6 ^{7/8}	11 ^{13/16}	9 ^{1/16}	3	11 ^{1/8}	20 ^{1/2}	9 ^{5/8}	8 ^{11/16}	33 ^{3/8}	1	217	37

Dimensions: mm

PHASE	SIZE ø	MODEL	OUTPUT KW	HP	QDC MODEL	QDC											PUMP & MOTOR						WEIGHT kg			
						A	B	C	H	J	M ₁	M ₂	N ₁	N ₂	P	R	S	ø1	F	G	L	Q	T	U	PUMP	QDC
THREE	50/80	50CLFU61.5	1.5	2	LM65	215	153	95	12	140	160	95	120	45	145	250	190	65	257	464	210	180	753	50	60	14
		80CLFU61.5	1.5	2	LM80	215	168	90	15	155	165	90	125	50	175	285	230	80	292	511	245	210	789	65	67	17
	80/100	100CLFU61.5	1.5	2	LM80	215	210	90	15	155	195	90	125	50	175	300	230	80	267	494	245	200	785	25	77	17
		100CLFU62.2	2.2	3	LM80	215	210	90	15	155	195	90	125	50	175	300	230	80	282	521	245	220	807	25	90	17
		100CLFU63.7	3.7	5	LM80	215	210	90	15	155	195	90	125	50	175	300	230	80	282	521	245	220	847	25	98	17

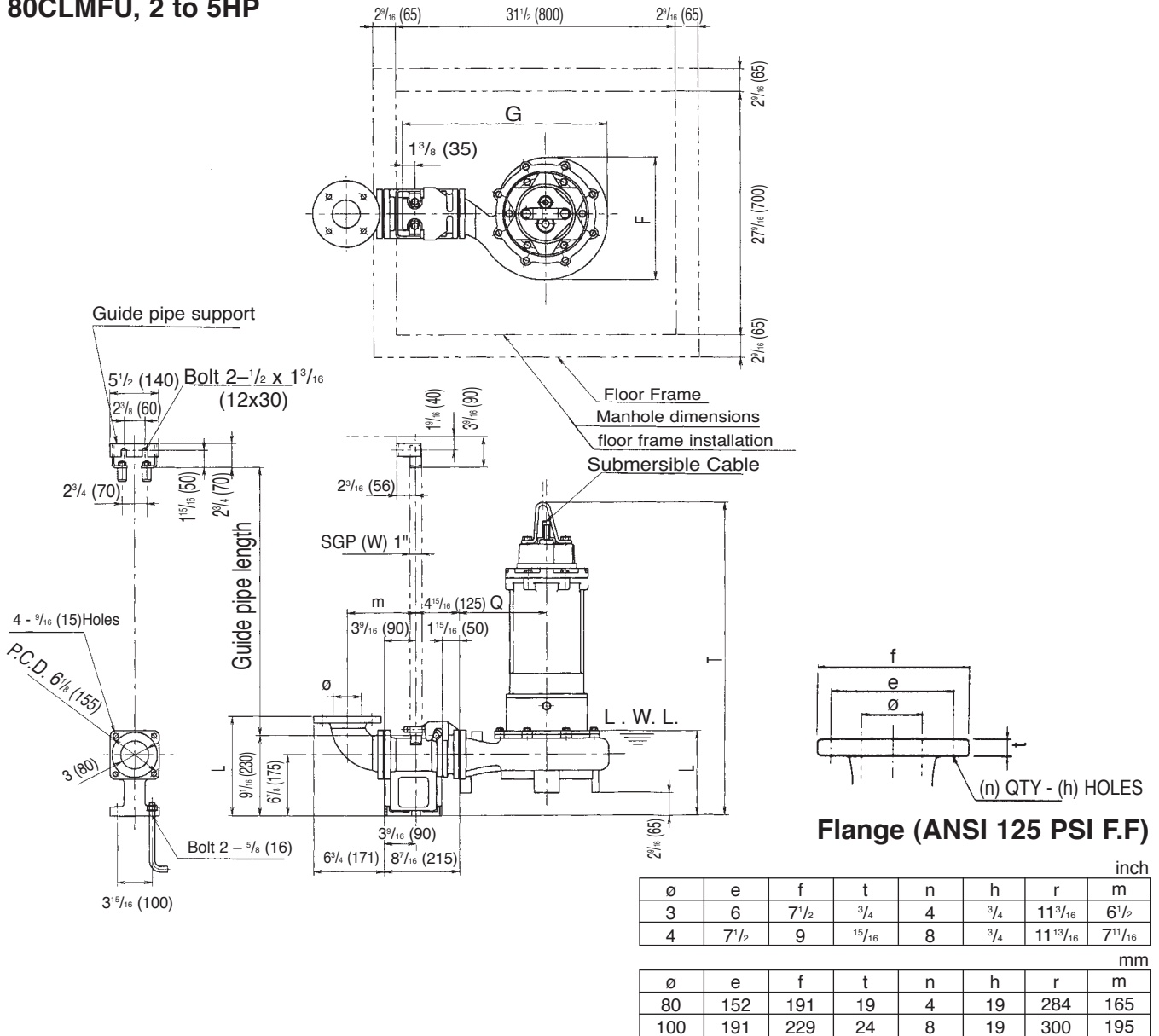
Model CLFU
EBARA PRO Cast Sewage Pumps
Dimensions
**Model CLFU with Quick Discharge Connector
80CLMFU, 2 to 5HP**

Dimensions: inch

PHASE	SIZE ø	PUMP MODEL	OUTPUT		Q.D.C. MODEL	PUMP & MOTOR					WEIGHT Lb	
			kW	HP		F	G	L	Q	T	PUMP	Q.D.C.
THREE	3/4	80CLMFU61.5	1.5	2	LM80	11 1/2	20 5/16	9 13/16	8 1/4	31 1/16	157	37
		80CLMFU62.2	2.2	3	LM80	11 1/2	20 5/16	9 15/16	8 1/4	32 1/16	187	37
		80CLMFU63.7	3.7	5	LM80	12 1/8	21	9 15/16	8 11/16	33 3/8	205	37

Dimensions: mm

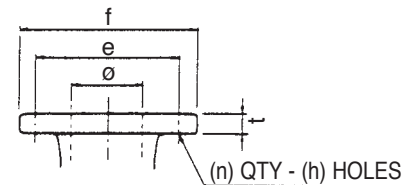
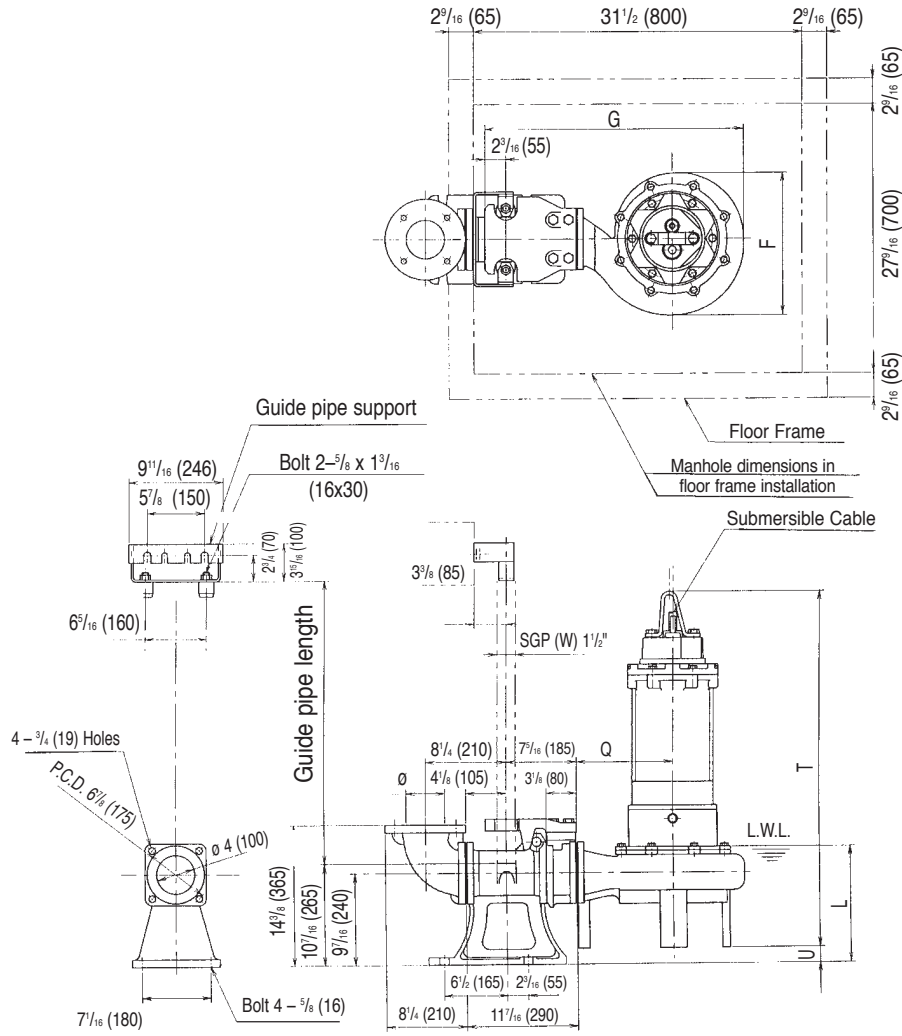
PHASE	SIZE ø	PUMP MODEL	OUTPUT		Q.D.C. MODEL	PUMP & MOTOR					WEIGHT kg	
			kW	HP		F	G	L	Q	T	PUMP	Q.D.C.
THREE	80/100	80CLMFU61.5	1.5	2	LM80	292	516	250	210	789	71	17
		80CLMFU62.2	2.2	3	LM80	292	516	253	210	815	85	17
		80CLMFU63.7	3.7	5	LM80	308	534	252	220	854	93	17

Model CLFU
EBARA PRO Cast Sewage Pumps
Dimensions
**Model CLFU with Quick Discharge Connector
80CLFU, 3 to 5HP**

Flange (ANSI 125 PSI F.F)

inch					
ø	e	f	t	n	h
3	6	7 1/2	3/4	4	3/4

mm					
ø	e	f	t	n	h
80	152	191	19	4	19

Dimensions: inch

PHASE	SIZE ø	MODEL	OUTPUT		Q.D.C. MODEL	PUMP & MOTOR						WEIGHT Lb	
			KW	HP		F	G	L	Q	T	U	PUMP	Q.D.C.
THREE	3/4	80CLFU62.2	2.2	3	LL100	13 3/16	25 3/8	12 5/8	9 1/4	34 3/4	4 1/2	209	101
		80CLFU63.7	3.7	5	LL100	13 3/16	25 3/8	12 5/8	9 1/4	36 5/16	4 1/2	209	101

Dimensions: mm

PHASE	SIZE ø	MODEL	OUTPUT		Q.D.C. MODEL	PUMP & MOTOR						WEIGHT kg	
			KW	HP		F	G	L	Q	T	U	PUMP	Q.D.C.
THREE	80/100	80CLFU62.2	2.2	3	LL100	335	644	320	235	883	115	95	46
		80CLFU63.7	3.7	5	LL100	335	644	320	235	923	115	95	46

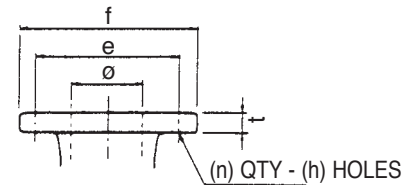
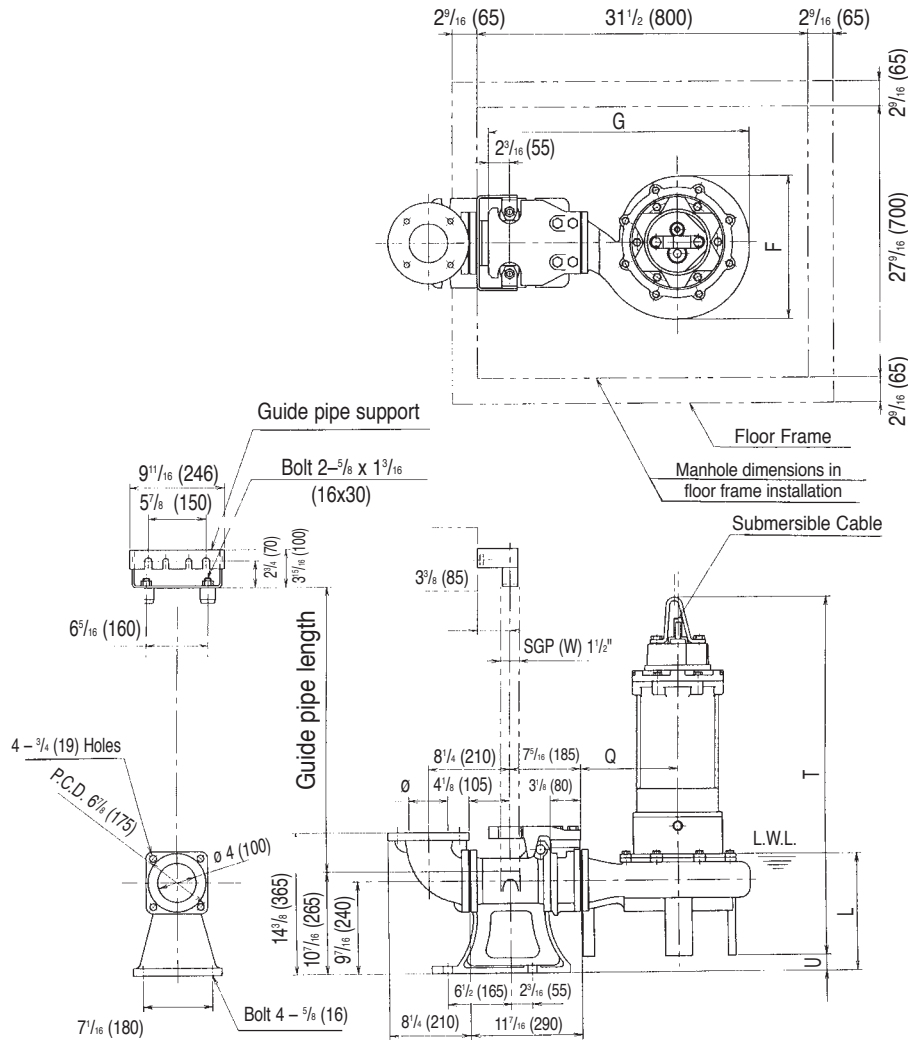
Model CLFU
EBARA PRO Cast Sewage Pumps
Dimensions
**Model CLFU with Quick Discharge Connector
100CLMFU, 3 to 5HP**

Flange (ANSI 125 PSI F.F)

inch					
ø	e	f	t	n	h
4	7 1/2	9	1 5/16	8	3/4

mm					
ø	e	f	t	n	h
100	191	229	24	8	19

Dimensions: inch

PHASE	SIZE ø	MODEL	OUTPUT		Q.D.C. MODEL	PUMP & MOTOR						WEIGHT Lb	
			kW	HP		F	G	L	Q	T	U	PUMP	Q.D.C.
THREE	3/4	100CLMFU62.2	2.2	3	LL100	13 3/16	25 3/8	12 7/8	9 1/4	34 3/4	4 1/2	209	101
		100CLMFU63.7	3.7	5	LL100	13 3/16	25 3/8	12 5/8	9 1/4	36 5/16	4 1/2	209	101

Dimensions: mm

PHASE	SIZE ø	MODEL	OUTPUT		Q.D.C. MODEL	PUMP & MOTOR						WEIGHT kg	
			kW	HP		F	G	L	Q	T	U	PUMP	Q.D.C.
THREE	80/100	100CLMFU62.2	2.2	3	LL100	335	644	320	235	883	115	95	46
		100CLMFU63.7	3.7	5	LL100	335	644	320	235	923	115	95	46

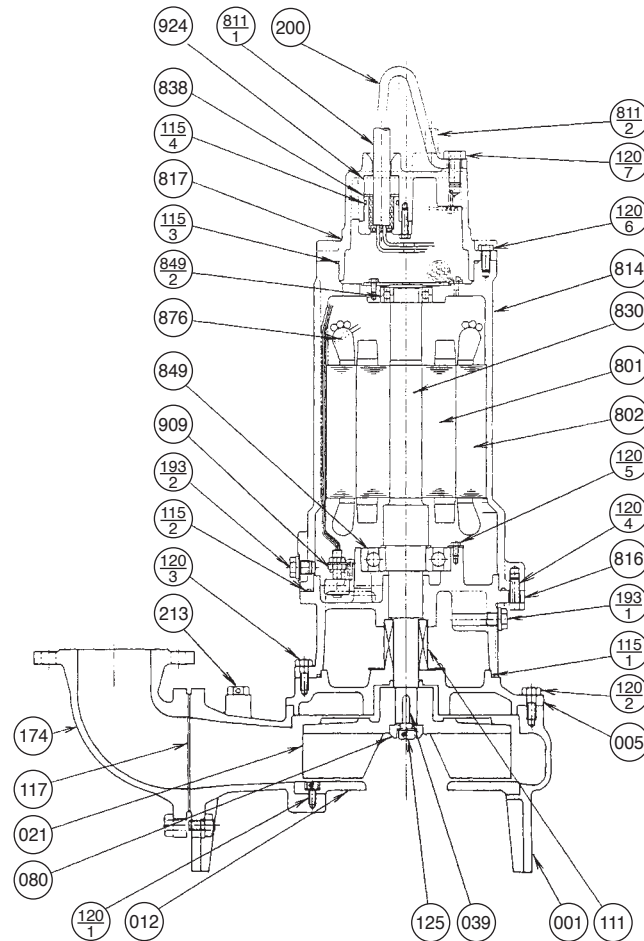
Model CLFU
EBARA PRO Cast Sewage Pumps
Sectional View
2 to 5HP

PART NO.	PART NAME	MATERIAL	ASTM, AISI CODE	NO. FOR 1 UNIT
001	CASING	CAST IRON	A48 Class 30	1
005	INTERMEDIATE CASING	CAST IRON	A48 Class 30	1
†012	SUCTION COVER	CAST IRON	A48 Class 30	1
†021	IMPELLER	CAST IRON	A48 Class 30	1
039	KEY	420 STAINLESS	AISI420	1
080	BUSHING	STEEL	A283 Grade D	1
†111	MECHANICAL SEAL	—		1 SET
†115-1	O-RING	RUBBER (NBR)		1
†115-2	O-RING	RUBBER (NBR)		1
†115-3	O-RING	RUBBER (NBR)		1
†115-4	O-RING	RUBBER (NBR)		2
†117	GASKET			1
120-1	BOLT	304 STAINLESS	AISI304	4
120-2	BOLT	304 STAINLESS	AISI304	8
120-3	BOLT	304 STAINLESS	AISI304	4
120-4	BOLT	304 STAINLESS	AISI304	4
120-5	BOLT	304 STAINLESS	AISI304	3
120-6	BOLT	304 STAINLESS	AISI304	4
120-7	BOLT	304 STAINLESS	AISI304	2
125	BOLT	304 STAINLESS	AISI304	1

PART NO.	PART NAME	MATERIAL	ASTM, AISI CODE	NO. FOR 1 UNIT
174	DISCHARGE ELBOW	CAST IRON	A48 Class 30	1
193-1	PLUG	304 STAINLESS	AISI304	1
193-2	PLUG	304 STAINLESS	AISI304	1
200	LIFTING HANGER	STEEL	A283 Grade D	1
213	AIR VENT VALVE	BRASS	B36 No. 272	1
801	ROTOR	—		1
802	STATOR	—		1
811-1	POWER CABLE	—		1
811-2	CONTROL CABLE	—		1
814	MOTOR COVER	CAST IRON	A48 Class 30	1
816	BRACKET	CAST IRON	A48 Class 30	1
817	BRACKET	CAST IRON	A48 Class 30	1
830	SHAFT	403 STAINLESS	AISI403	1
838	WASHER	304 STAINLESS	AISI304	2
†849-1	BALL BEARING	—		1
†849-2	BALL BEARING	—		1
876	MOTOR PROTECTOR	—		3
909	LEAKAGE DETECTOR	—		1
924	PACKING	RUBBER (NBR)		2

Motors are purchased as a complete unit

†: Recommended spare parts