

Contents

Model

32CGUII61.5S

32CGFU61.5S

32CGFU61.5

50CGFU62.2S

50CGFU62.2

50CGFU63.7S

50CGFU63.7

Section	Page
Specifications	1802
Selection Chart	1803
Performance Curves	1806
Dimensions	1808
Sectional View	1813
QDC Information	2100
Motor Data	2200
motor electrical specifications	
cable data	
wiring diagrams	
motor electrical data	

Model CGUI/CGFU

EBARA PRO Cast Grinder Pumps

Model Designation

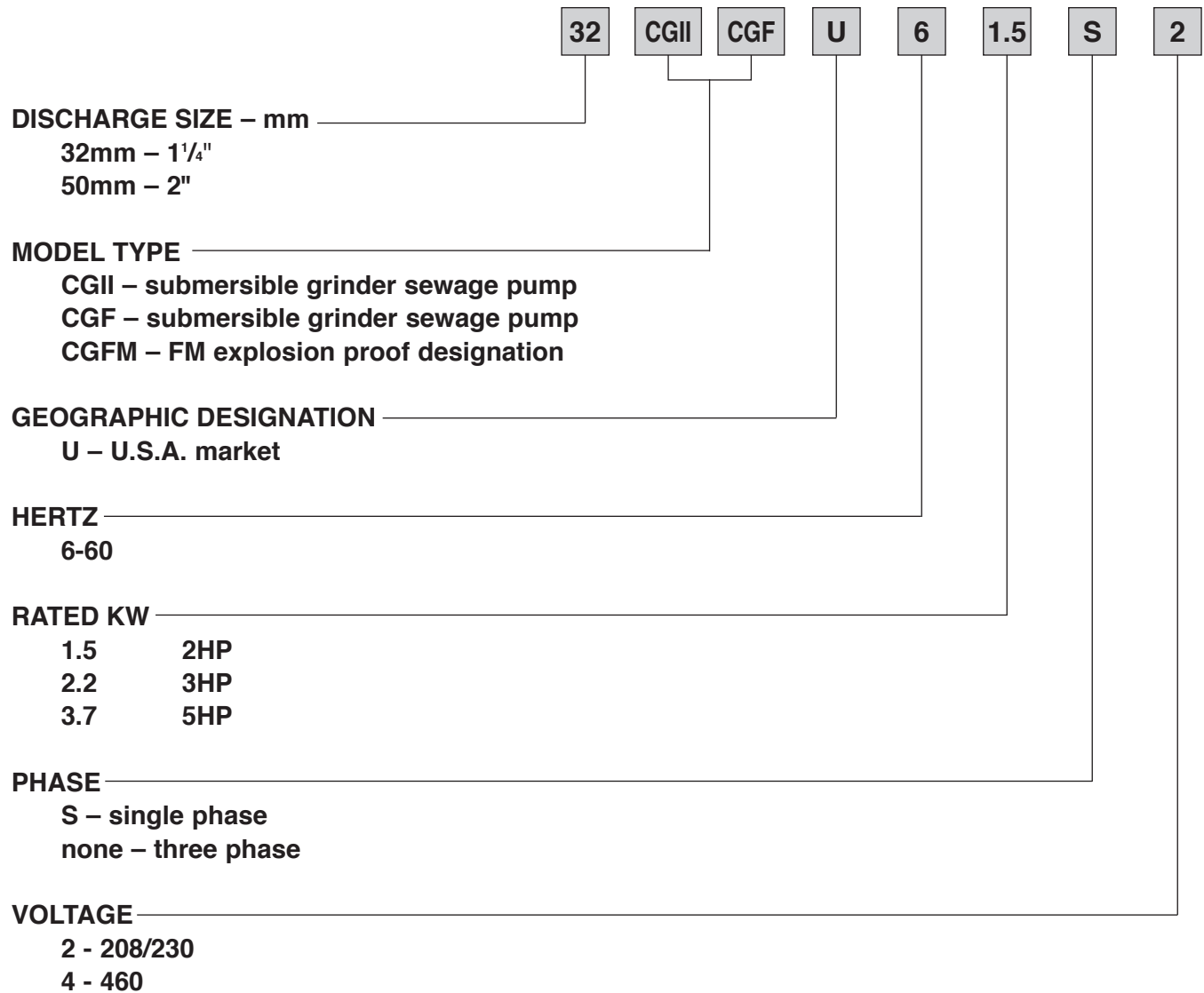

Specification

	Standard	Optional
Size	1¼ inch	
Range of HP Range of Performance	2 HP Single Phase Capacity 5 to 30 GPM Head 27 to 112 feet	
Limitation Maximum Water Temperature	104°F (40°C)	
Synchronous Speed	3600 RPM	
Materials Casing Impeller Grinder Impeller Grinder Disk Shaft Motor Frame Fastener	Cast Iron Cast Iron High Chrome Cast Iron HRC 60 High Chrome Cast Iron HRC 60 403 Stainless Steel Cast Iron 304 Stainless Steel	
Mechanical Seal Material – Upper Side Material – Lower Side Impeller Type Bearing – Upper/Lower Side Motor Single Phase Motor Protection Single Phase Accessories	Double Mechanical Seal Carbon/Ceramic Silicon Carbide/Silicon Carbide Vortex Impeller Prelubricated Ball Bearing Air-filled, Insulation Class F 208/230V Built-in Auto Cut, overload, no load, out of phase, and single phasing protection Submersible cable 33 ft.	66 ft. QDC System

Single phase

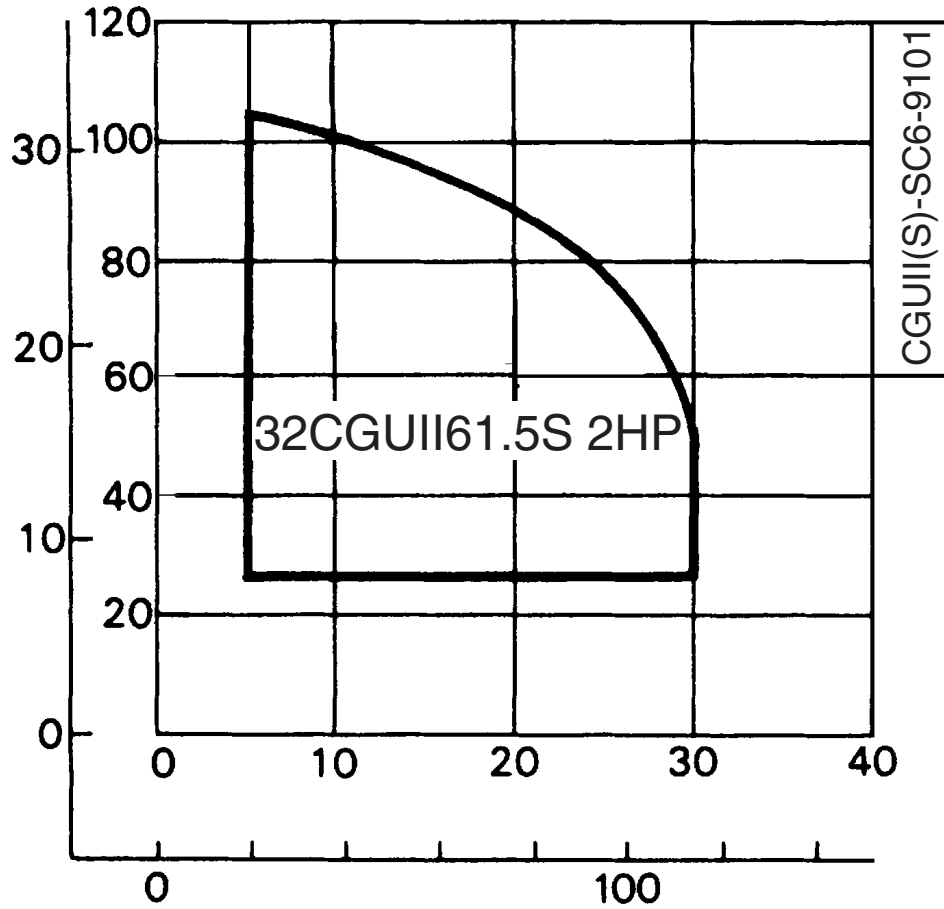

Specification

	Standard	Optional
Size	1¼, 2 inch	
Range of HP Range of Performance	2 to 5HP Single and Three Phase Capacity 5 to 80 GPM Head 27 to 148 feet	
Limitation Maximum Water Temperature	104°F (40°C)	
Synchronous Speed	3600 RPM	
Materials Casing Impeller Grinder Impeller Grinder Disk Shaft Motor Frame Fastener	Cast Iron Cast Iron High Chrome Cast Iron HRC 60 High Chrome Cast Iron HRC 60 403 Stainless Steel Cast Iron 304 Stainless Steel	
Mechanical Seal Material – Upper Side Material – Lower Side Impeller Type Bearing – Upper/Lower Side Motor Single Phase Three Phase Motor Protection Accessories	Double Mechanical Seal Carbon/Ceramic Silicon Carbide/Silicon Carbide Vortex Impeller Prelubricated Ball Bearing Insulation Class F 208/230V 208/230/460V Built-in Thermal Detector – Klixon Built-in Mechanical Seal Leakage Detector Submersible cable 33 ft.	FM Explosion Proof Class 1, Division 1, Group C, D ____ ft. (customer specified) QDC System

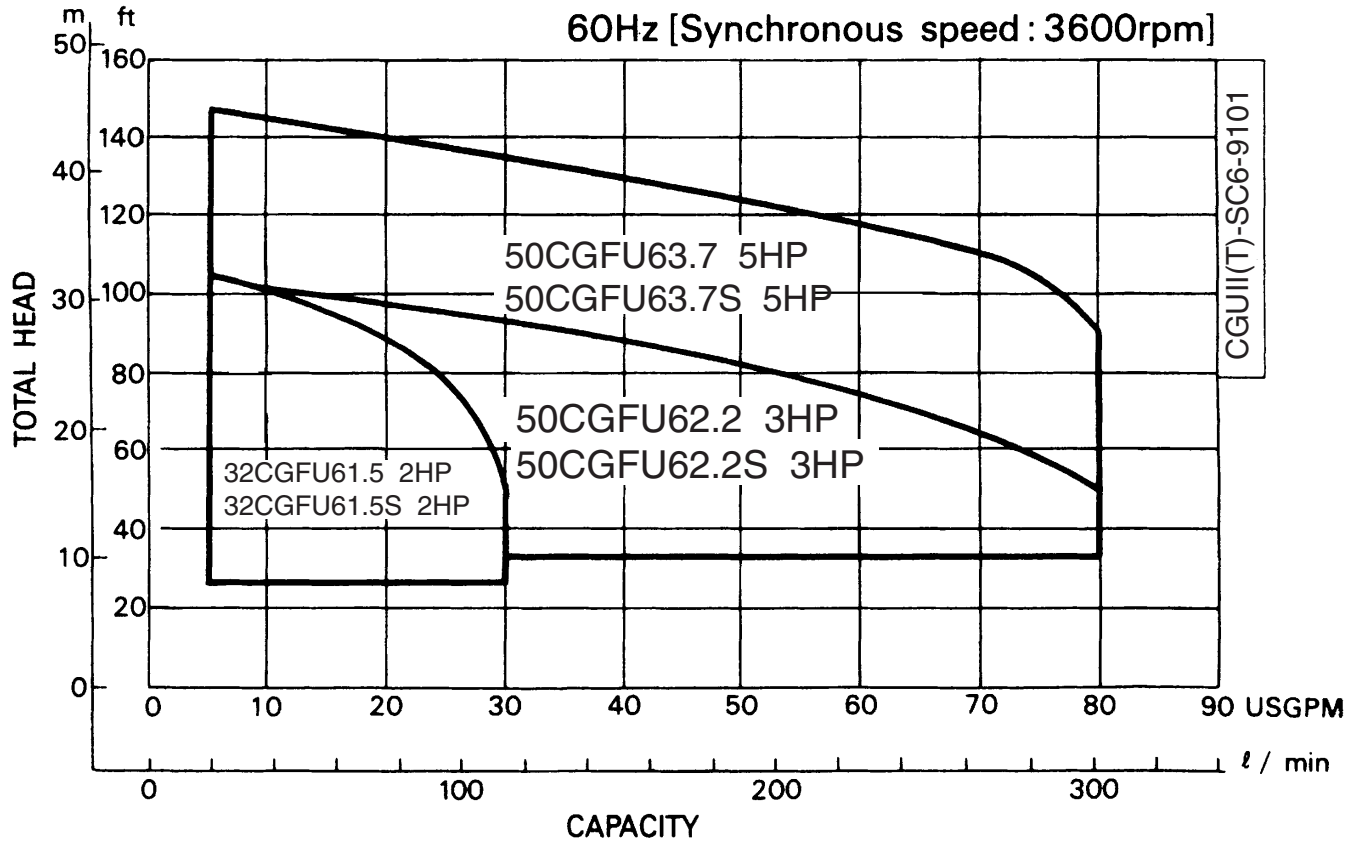
Single and Three Phase

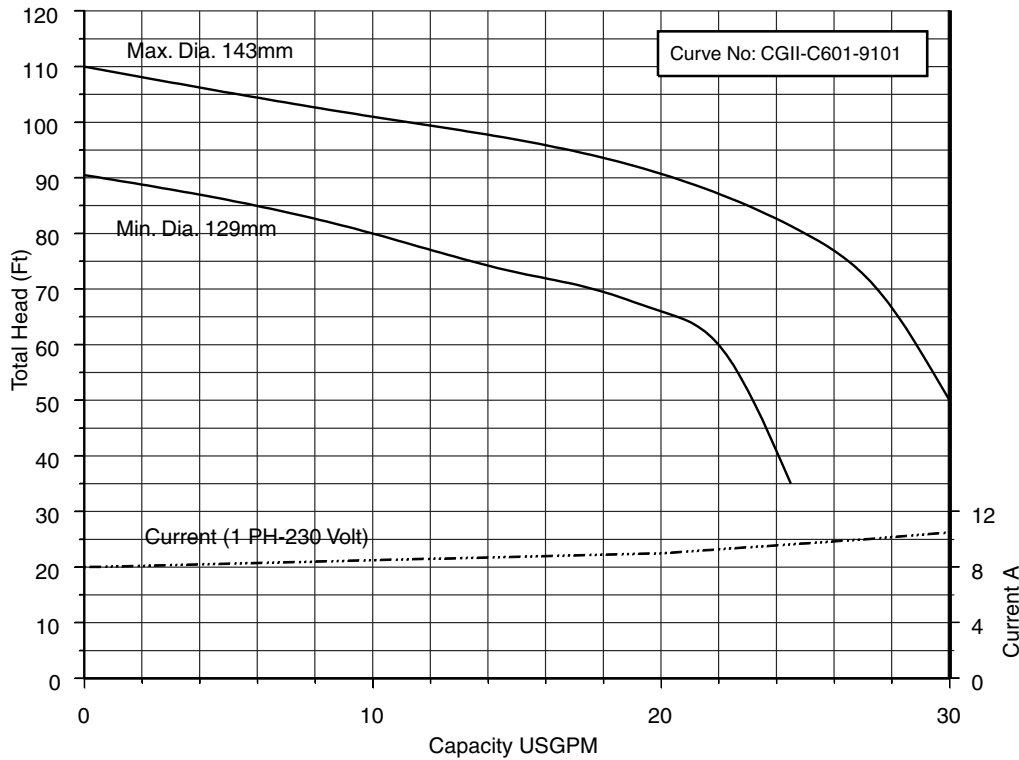
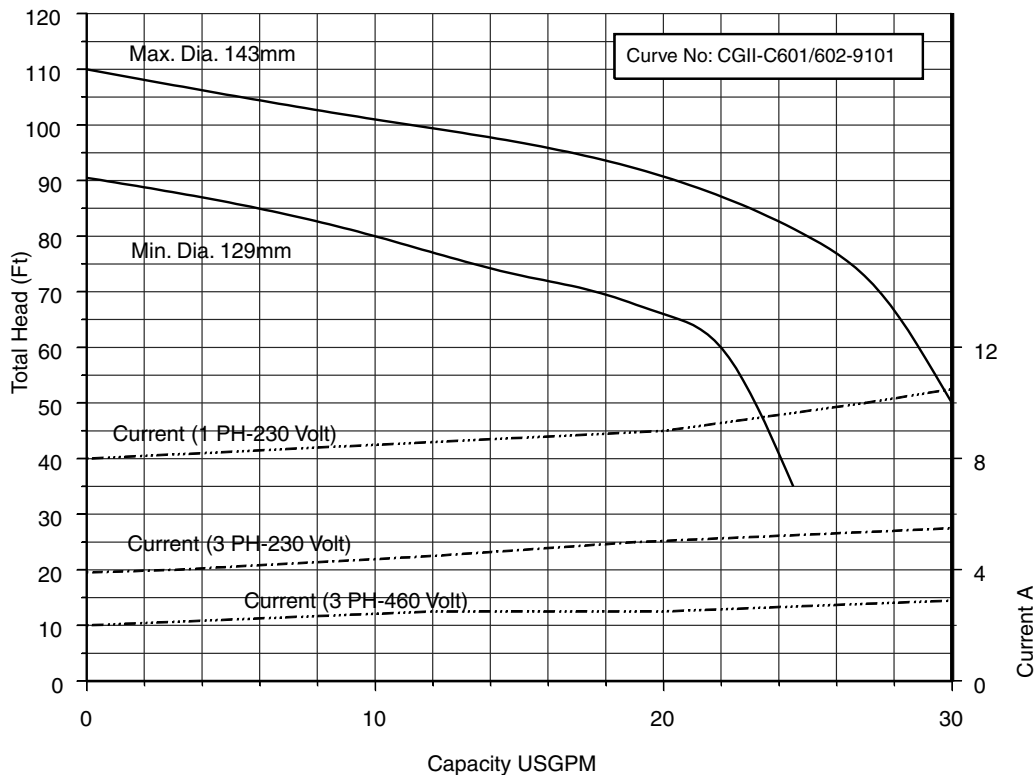
32CGUI61.5S (2HP) Synchronous Speed: 3600 RPM
1 1/4 inch Discharge

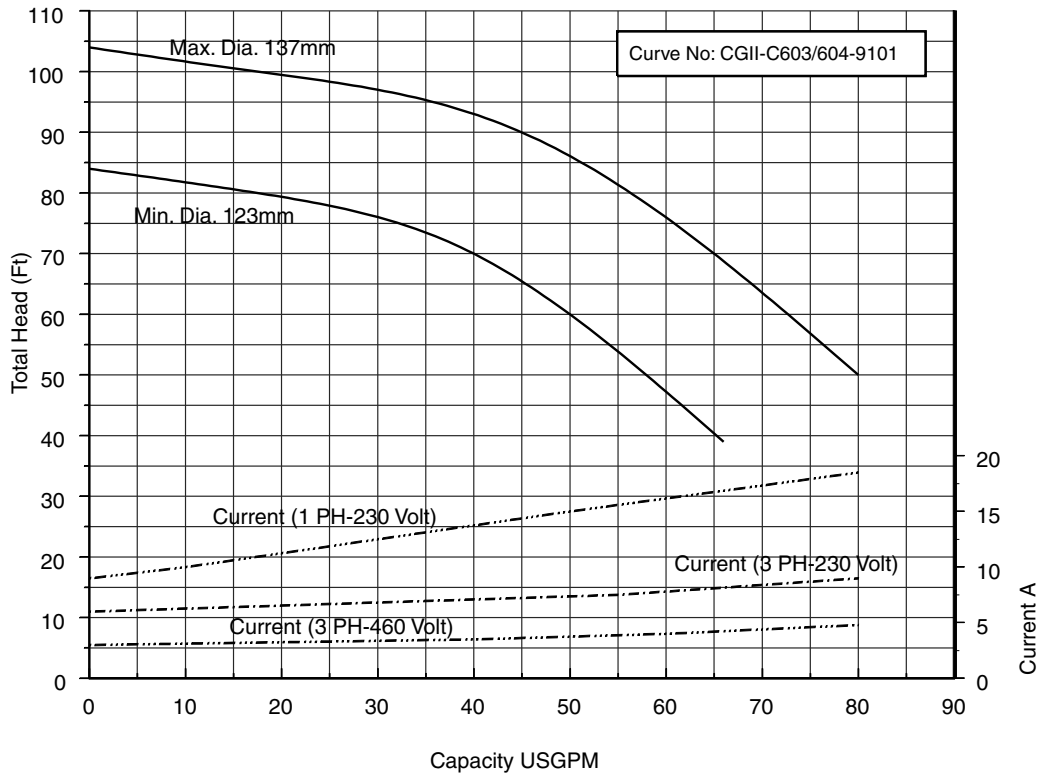
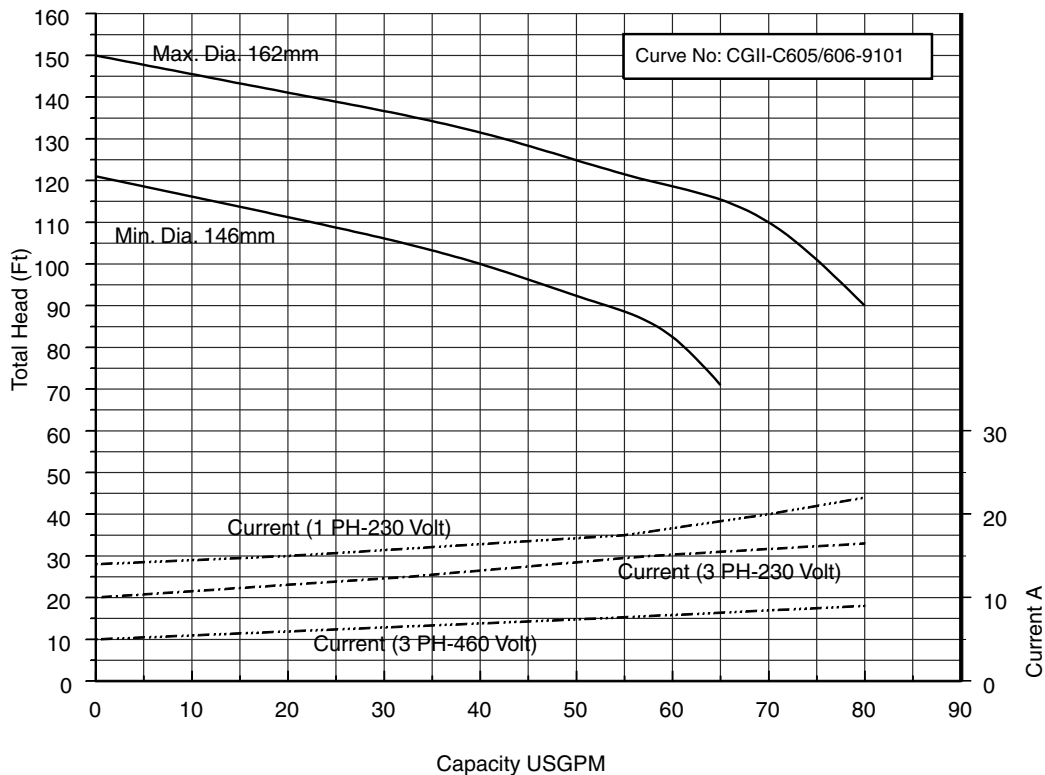
32CGF61.5S 32CGFU61.5 (2HP) Synchronous Speed: 3600 RPM 1 1/4 inch Discharge

50CGF62.2S 50CGFU62.2 (3HP) Synchronous Speed: 3600 RPM 2 inch Discharge

50CGF63.7S 50CGFU63.7 (5HP) Synchronous Speed: 3600 RPM 2 inch Discharge

Model CGUI/CGFU

EBARA PRO Cast Grinder Pumps

Dimensions

Model CGUI, Single Phase

32CGUI

Unit: inch (mm)

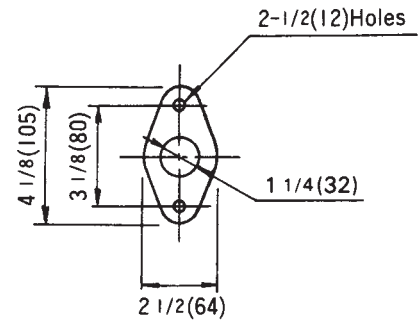
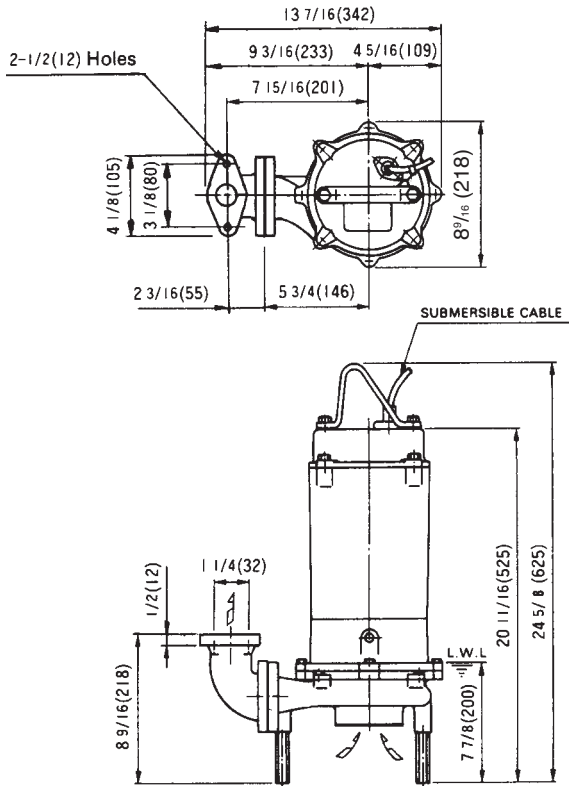

Flange

MODEL	WEIGHT (Lb/kg)
32CGUI61.5S	93 (42)

Model CGUI/CGFU

EBARA PRO Cast Grinder Pumps

Dimensions

Model CGFU, Single Phase and Three Phase

32CGFU, 2HP

50CGFU, 3 to 5HP

Unit: Inch (mm)

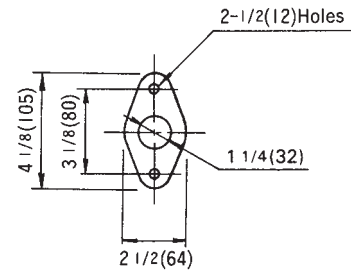
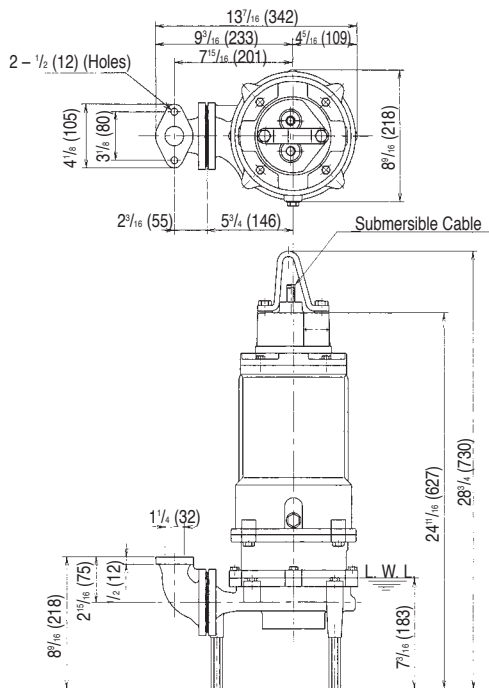

Flange

MODEL	WEIGHT – Lb (kg)
32CGFU61.5S	126 (57)
32CGFU61.5	128 (58)

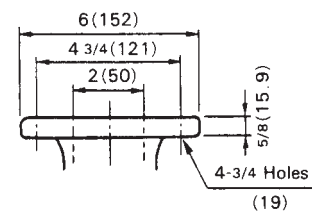
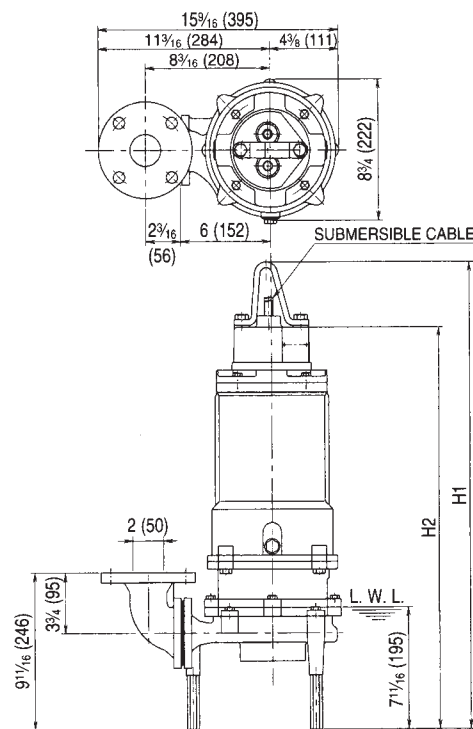

Flange (ANSI 125 PSI F.F)

PHASE	MODEL	PUMP & MOTOR		WEIGHT Lb (kg)
		H ₁ inch (mm)	H ₂ inch (mm)	
SINGLE	50CGFU62.2S	31 1 1/16 (805)	27 5/8 (702)	174 (79)
	50CGFU63.7S	35 11/16 (907)	31 5/8 (804)	223 (101)
THREE	50CGFU62.2	30 1/8 (765)	26 1/16 (662)	159 (72)
	50CGFU63.7	31 1 1/16 (805)	27 5/8 (702)	174 (79)

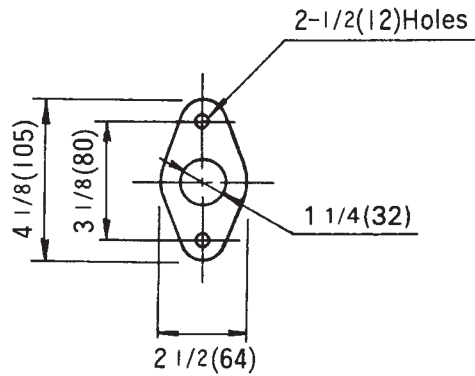
Dimensions
Model CGUI, with Quick Discharge Connector, Single Phase
32CGUI, 2HP
Flange

LM50

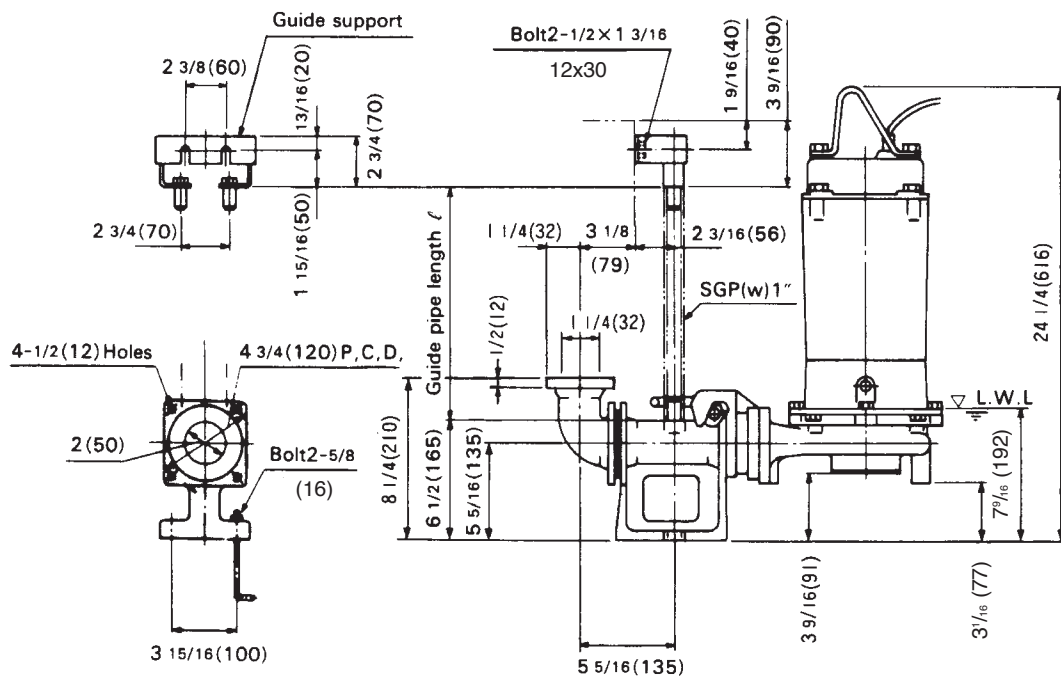
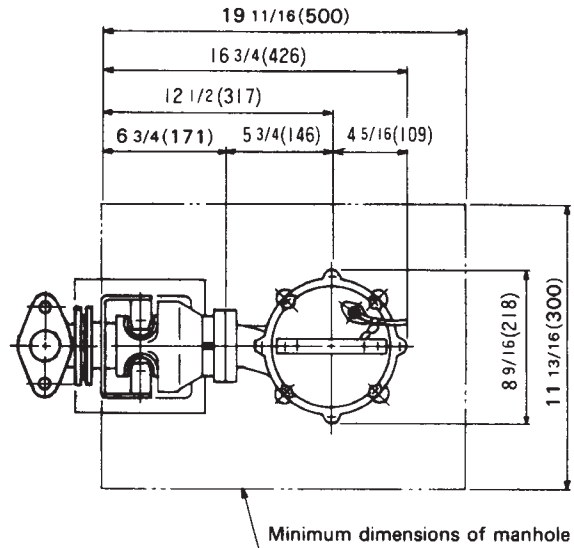
Unit : Inch (mm)



PHASE	MODEL	WEIGHT (Lb)		WEIGHT (kg)	
		Pump	Q.D.C.	Pump	Q.D.C.
SINGLE	32CGUI161.5S	93	24	42	11

Dimensions
**Model CGFU, with Quick Discharge Connector, Single and Three Phase
32CGFU, 2HP**
LM50

Unit : Inch (mm)

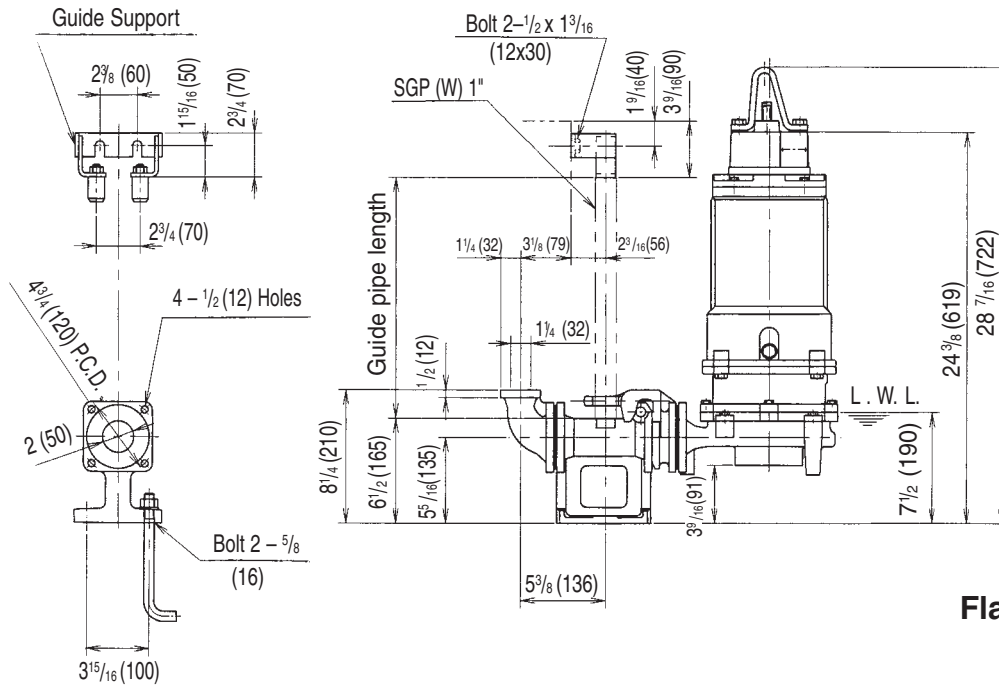
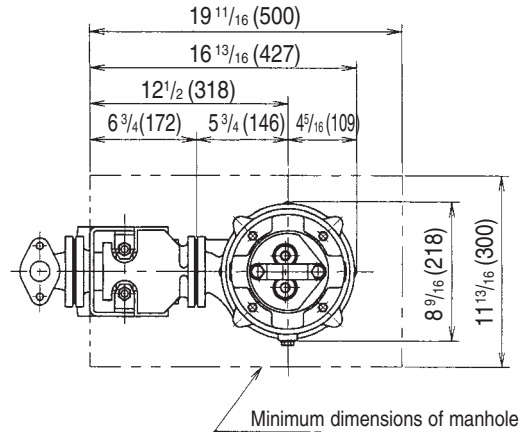
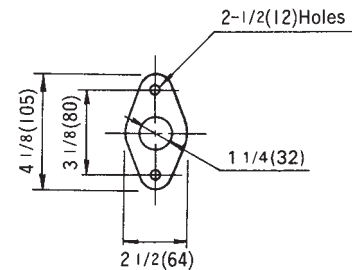
Flange

PHASE	MODEL	WEIGHT (Lb)		WEIGHT (kg)	
		Pump	Q.D.C.	Pump	Q.D.C.
SINGLE	32CGFU61.5S	126	24	57	11
THREE	32CGFU61.5	128	24	58	11

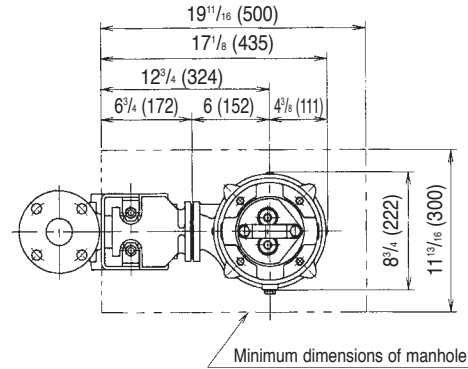
Model CGUI/CGFU
EBARA PRO Cast Grinder Pumps
Dimensions
Model CGFU, with Quick Discharge Connector, Single and Three Phase
50CGFU, 3 to 5HP

LM50

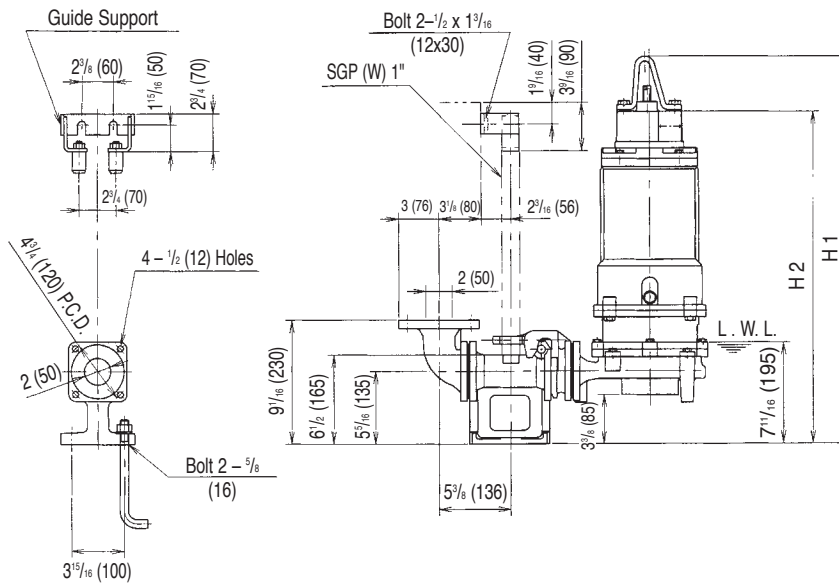
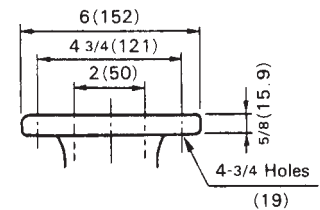
Unit : Inch (mm)

Flange (ANSI 125 PSI F.F)

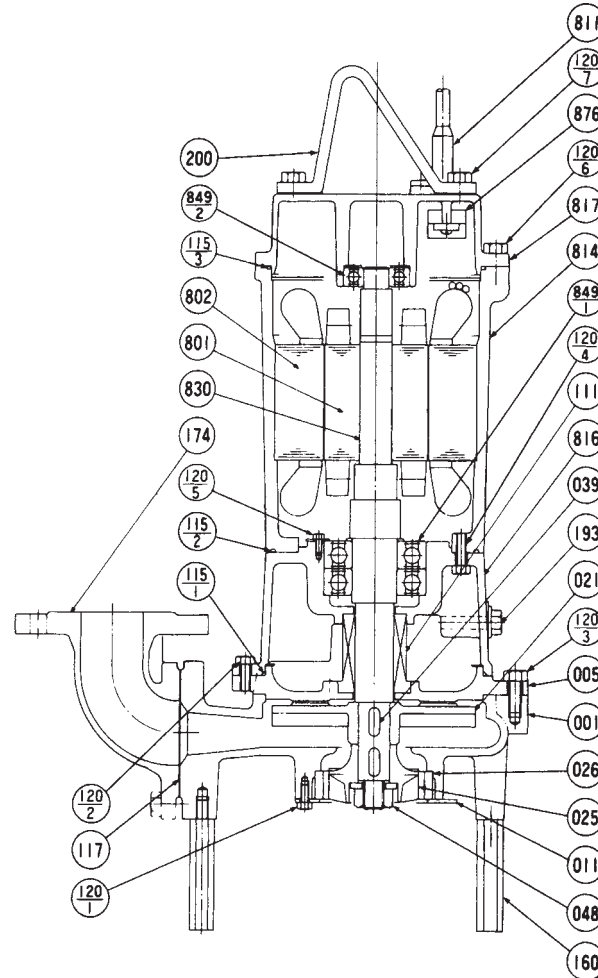
PHASE	MODEL	PUMP & MOTOR		WEIGHT – Lb (kg)	
		H ₁ inch (mm)	H ₂ inch (mm)	Pump	Q.D.C.
SINGLE	50CGFU62.2S	31 1/16 (789)	27 (686)	174 (79)	24 (11)
	50CGFU63.7S	35 1/16 (891)	31 (788)	223 (101)	24 (11)
THREE	50CGFU62.2	29 1/2 (749)	25 7/16 (646)	159 (72)	24 (11)
	50CGFU63.7	31 1/16 (789)	27 (686)	174 (79)	24 (11)

Model CGUI/CGFU
EBARA PRO Cast Grinder Pumps
Sectional View
Single Phase
32CGUII

PART NO.	PART NAME	MATERIAL	ASTM, AISI CODE	NO. FOR 1 UNIT	PART NO.	PART NAME	MATERIAL	ASTM, AISI CODE	NO. FOR 1 UNIT
001	CASING	CAST IRON	A48 Class 30	1	120-5	BOLT	304 STAINLESS	AISI304	2
005	INTERMEDIATE CASING	CAST IRON	A48 Class 30	1	120-6	BOLT	304 STAINLESS	AISI304	4
011	DISK COVER	304 STAINLESS	AISI304	1	120-7	BOLT	304 STAINLESS	AISI304	2
†021	IMPELLER	CAST IRON	A48 Class 30	1	160	PUMP STAND	STEEL	A283 Grade D	3
†025	GRINDER IMPELLER	CHROME ALLOYED CAST IRON		1	174	DISCHARGE ELBOW	CAST IRON	A48 Class 30	1
†026	CUTTER RING	CHROME ALLOYED CAST IRON		1	193	OIL PLUG	304 STAINLESS	AISI304	1
039	KEY	420 STAINLESS	AISI420	2	200	LIFTING HANGER	STEEL	A283 Grade D	1
048	IMPELLER NUT	304 STAINLESS	AISI304	1	801	ROTOR	—		1
†111	MECHANICAL SEAL	—		1 SET	802	STATOR	—		1
†115-1	O-RING	RUBBER (NBR)		1	†811	SUBMERSIBLE CABLE	—		1
†115-2	O-RING	RUBBER (NBR)		1	814	MOTOR FRAME	CAST IRON	A48 Class 30	1
†115-3	O-RING	RUBBER (NBR)		1	816	BRACKET	CAST IRON	A48 Class 30	1
†117	GASKET			1	817	BRACKET	CAST IRON	A48 Class 30	1
120-1	BOLT	304 STAINLESS	AISI304	4	830	SHAFT	403 STAINLESS	AISI403	1
120-2	BOLT	304 STAINLESS	AISI304	4	†849-1	BALL BEARING	—		1
120-3	BOLT	304 STAINLESS	AISI304	4	†849-2	BALL BEARING	—		1
120-4	BOLT	304 STAINLESS	AISI304	4	876	MOTOR PROTECTOR	—		1

Motors are purchased as a complete unit

†: Recommended spare parts



EBARA Fluid Handling
www.pumpsebara.com

(t) 803 327-5005 • (f) 803 327-5097

Model CGUI/CGFU
EBARA PRO Cast Grinder Pumps
Sectional View
Single and Three Phase

32CGFU, 2HP

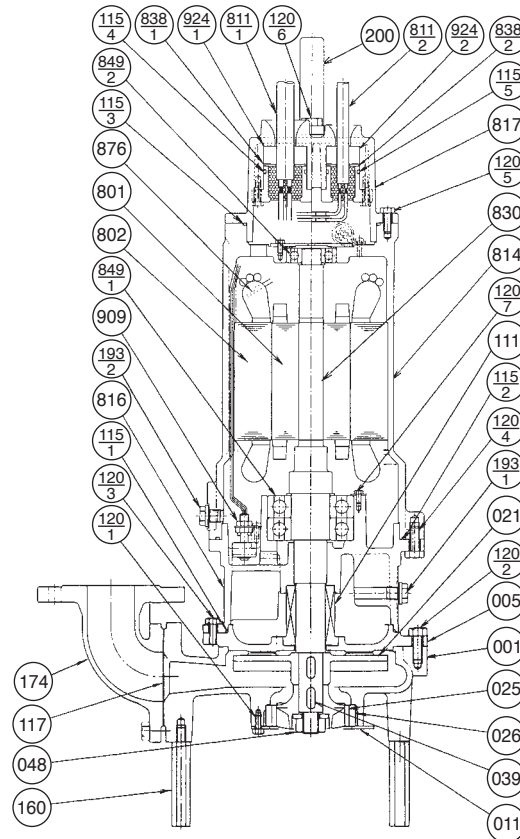
50CGFU 3 to 5HP



PART NO.	PART NAME	MATERIAL	ASTM, AISI CODE	NO. FOR 1 UNIT	PART NO.	PART NAME	MATERIAL	ASTM, AISI CODE	NO. FOR 1 UNIT
001	CASING	CAST IRON	A48 Class 30	1	160	PUMP STAND	STEEL	A283 Grade D	3
005	INTERMEDIATE CASING	CAST IRON	A48 Class 30	1	174	DISCHARGE ELBOW	CAST IRON	A48 Class 30	1
011	DISK COVER	304 STAINLESS	AISI304	1	193-1	PLUG	304 STAINLESS	AISI304	1
†021	IMPELLER	CAST IRON	A48 Class 30	1	193-2	PLUG	304 STAINLESS	AISI304	1
†025	GRINDER IMPELLER	CHROME ALLOYED CAST IRON		1	200	LIFTING HANGER	STEEL	A283 Grade D	1
†026	CUTTER RING	CHROME ALLOYED CAST IRON		1	801	ROTOR	—		1
039	KEY	420 STAINLESS	AISI420	2	802	STATOR	—		1
048	IMPELLER NUT	304 STAINLESS	AISI304	1	811-1	POWER CABLE	—		1
†111	MECHANICAL SEAL	—		1 SET	811-2	CONTROL CABLE	—		1
†115-1	O-RING	RUBBER (NBR)		1	814	MOTOR FRAME	CAST IRON	A48 Class 30	1
†115-2	O-RING	RUBBER (NBR)		1	816	BRACKET	CAST IRON	A48 Class 30	1
†115-3	O-RING	RUBBER (NBR)		1	817	BRACKET	CAST IRON	A48 Class 30	1
†115-4	O-RING	RUBBER (NBR)		1	830	SHAFT	403 STAINLESS	AISI403	1
†115-5	O-RING	RUBBER (NBR)		1	838-1	WASHER	304 STAINLESS	AISI304	1
†117	GASKET			1	838-2	WASHER	304 STAINLESS	AISI304	1
120-1	BOLT	304 STAINLESS	AISI304	4	†849-1	BALL BEARING	—		1 SET
120-2	BOLT	304 STAINLESS	AISI304	4	†849-2	BALL BEARING	—		1
120-3	BOLT	304 STAINLESS	AISI304	4	876	MOTOR PROTECTOR	—		3
120-4	BOLT	304 STAINLESS	AISI304	4	909	LEAKAGE DETECTOR	—		1
120-5	BOLT	304 STAINLESS	AISI304	4	924-1	PACKING	RUBBER (NBR)		1
120-6	BOLT	304 STAINLESS	AISI304	2	924-2	PACKING	RUBBER (NBR)		1
120-7	BOLT	304 STAINLESS	AISI304	3					

Motors are purchased as a complete unit

†: Recommended spare parts