

MP PUMPS SERVICE PARTS LIST

- Self Priming
- Engine Mounting

Poly 200® 2" x 2" Pipe Size

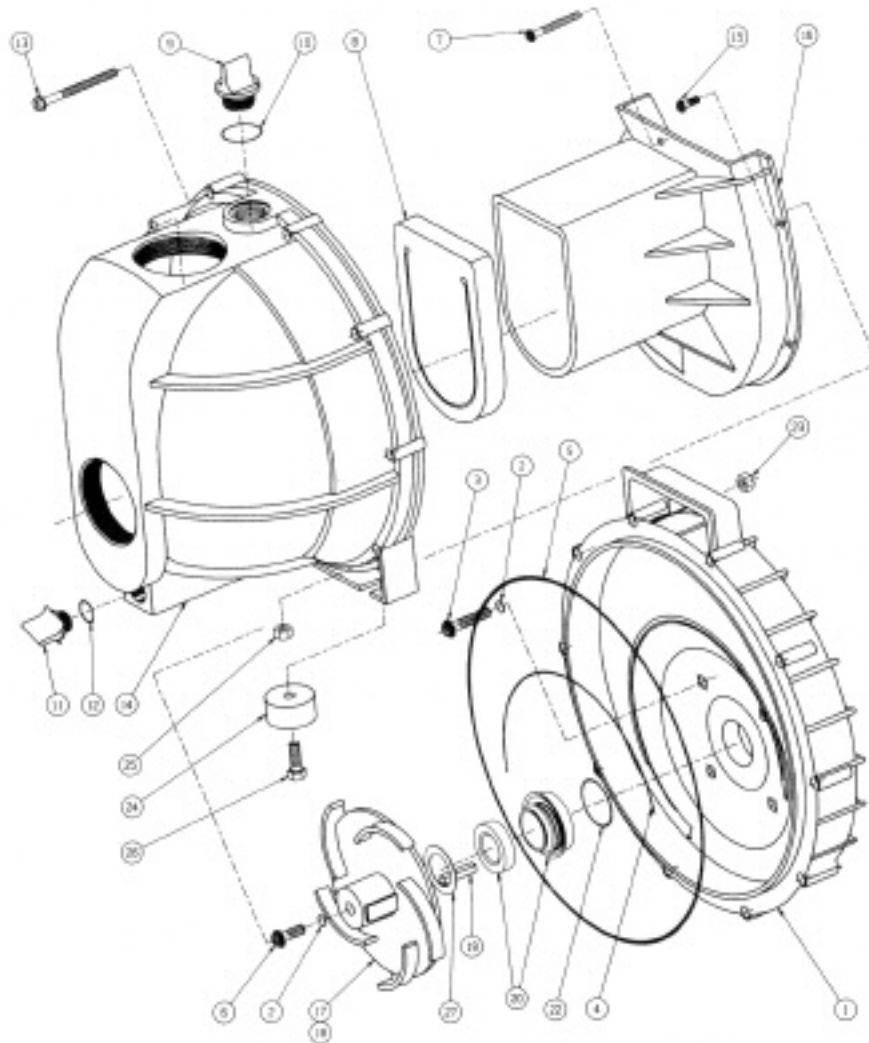

ITEM	PART NO.	DESCRIPTION	QTY.	ITEM	PART NO.	DESCRIPTION	QTY.
POLY 200® PUMP							
1	29096	ADAPTER	1	14	29109	HOUSING	1
2	29097	O-RING EPDM	5	15	29110	#8 X .5 SELF TAPPING SCR	4
3	29098	5/16-24 X 1.25 LG. SS PAN HD SCR	4	16	29111	VOLUTE	1
4	29099	O-RING SEGMENT EPDM	1	17	29112	IMPELLER FOR 3.5 HP	1
5	29100	O-RING FOR HOUSING EPDM	1	18	29113	IMPELLER FOR 5 HP (SHOWN)	1
6	29101	5/16-24 X .75 LG. SS PAN HD SCR	1	19	29114	3/16 X 3/16 X 1" LG. SS KEY	1
7	29102	10-24 X 1.5 LG. SS PAN HD SCR	1	20	29115	SEAL ASSEMBLY EPDM	1
8	29103	FLAPPER VALVE EPDM	1	22	29117	SHAFT SEAL O-RING EPDM	1
9	29104	FILL PLUG	1	23	29118	1/4-20 HEX HD NUT SS	10
10	29105	O-RING FOR FILL PLUG EPDM	1	24	29119	RUBBER FEET	4
11	29106	DRAIN PLUG	1	25	29120	1/4-20 FLANGED HEX NUT	2
12	29107	O-RING FOR DRAIN PLUG EPDM	1	26	29121	1/4-20 X .75 LG FLANGE HH CAPSCREW	2
13	29108	1/4-20 X 2.5 SS SLOTTED FLANGE HD SCR	10	27	29122	SHIMS	VAR



MP PUMPS, INC.

34800 BENNETT • FRASER, MI 48026-1686
 (586) 293-8240 • FAX (586) 293-8469
 (800) 563-8006 • www.mppumps.com

FORM 3040-B

PRINTED IN U.S.A. (3-99)

POLY 200® PUMP ASSEMBLY INSTRUCTIONS

1. Installation of seal:
 - A) Coat the rubber portion of the seal seat part #20 with a light grease.
 - B) Press the seal seat squarely into the recess in the impeller, part #17. Avoid scratching the polished surface of the seal seat.
 - C) With the seal seat in place, verify that it is clean and has not been marred.
 - D) Using a clean cloth, wipe the shaft and make certain that it is clean.
 - E) Place the shaft seal o-ring part #22 on the seal head part #20 behind the flange. Press the seal head with the o-ring into the adapter part #1.
2. Install adapter part #1 to engine using (4) screws part #3 and (4) o-rings part #2. Tighten adapter screws evenly to avoid misalignment.
3. Place key part #19 into the impeller keyslot. Slide impeller onto shaft, apply grease to o-ring part #2, slide onto screw part #6 and secure to shaft.
4. Rotate the shaft to check for impeller/adapter rubbing. If a rub occurs, remove the impeller and install shim washers part #27 between the shaft end and impeller.
5. Install o-ring segment part #4 into groove in adapter.
6. Install volute part #16 to adapter using (4) screws part #15 and (1) screw part #7. Tighten screws evenly.
7. Slide flapper part #8 onto volute.
8. Place o-ring part #5 on adapter.
9. Secure housing part #14 to adapter using (10) screws part # 13 and (10) hex nuts part #23. Tighten screws evenly.
10. Install fill plug part #9 and o-ring part #10 to housing.
11. Install drain plug part #11 and o-ring part #12 to housing.
12. Place rubber feet part #24 on screw part #26 and install as shown to housing using flanged hex nut part #25.
13. Connect hoses or pipe and fill with water before starting.



MP PUMPS, INC.

34800 BENNETT • FRASER, MI 48026-1686
(586) 293-8240 • FAX (586) 293-8469
(800) 563-8006 • www.mppumps.com

FORM 3040-B

PRINTED IN U.S.A. (3-99)